

PROPOSAL FOR A NEW ADDENDUM TO THE 1997 AGREEMENT CONCERNING THE
ADOPTION OF UNIFORM CONDITIONS FOR PERIODICAL TECHNICAL INSPECTIONS
OF WHEELED VEHICLES

Note: The text reproduced below was prepared by the experts from ISO in order to propose the adoption of certain provisions given in ISO/TS 20825:2003 as a basis for a new Rule with uniform provisions for Periodical Technical Inspections of wheeled vehicles with regard to the wear of mechanical couplings used in combinations of heavy vehicles.

A. JUSTIFICATION

ISO/TS 20825 "Road vehicles — Drawbar couplings, drawbar eyes, fifth wheel kingpins, hook couplings and toroidal eyes — Wear limits for in-use mechanical couplings" has been published by ISO on March 2003.

This International Standard has been developed by ISO/TC22/SC15/WG4 "Mechanical couplings", and the rationale for its development is clearly explained by its Introduction, as follows:

"This Technical Specification is intended to provide limits to the wear of standardized mechanical couplings mounted on heavy commercial vehicles, in order to ensure their safe on-road operation.

This Technical Specification has been considered necessary because the lack of any compulsory requirement applicable to the allowable wear of mechanical couplings has meant that the competent authorities, when checking in-use vehicles, make reference only to the design dimensions of standardized mechanical couplings. Nor have they been taking into consideration the wear limits indicated by each mechanical coupling manufacturer on the instructions for use and maintenance of the coupling.

This Technical Specification is addressed to all parties involved in the safe use of heavy commercial vehicles, i.e. the owner, any competent person who conducts the periodical maintenance and the competent authorities conducting the periodical inspection and check of in-use vehicles."

Therefore ISO/TC22/SC15 and its WG4 would like to submit to GRRF the proposal shown in the following pages for appropriate consideration and possible adoption as a new addendum to the 1997 Agreement on Periodical Technical Inspections.

B. PROPOSAL

Uniform provisions for PTI with regard to the wear of in-use mechanical couplings for heavy vehicles

1 Scope

This document is intended to give guidance on the requirements for PTI of in-use mechanical couplings. It specifies the limit dimensions of worn components of in-use mechanical couplings the respect of which assures safe operation on road.

This document is applicable to the following mechanical couplings, with reference to the appropriate clause in Annex 5 to UNECE Regulation No. 55, Rev.1:

- Class C50 drawbar couplings (clause 3);
- Class D50 drawbar eyes (clauses 4.1 and 4.2);
- Class H50 fifth wheel kingpins (clause 8);
- Class K hook couplings (clause 10);
- Class L toroidal eyes (clause 4.4);

2 Requirements concerning the technical inspection

2.1 General

Worn components of in-use mechanical couplings shall be checked either by direct measurement or by the use of special gauges.

2.2 Class C50 drawbar couplings

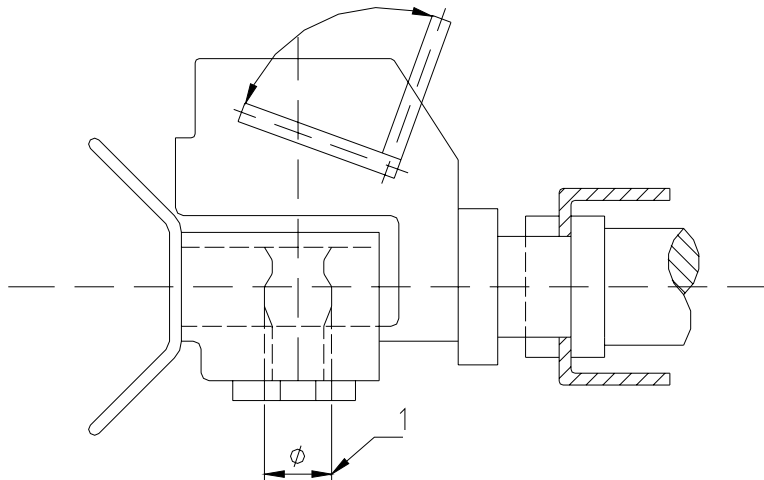

Key

- 1 dimension to be checked

Figure 1 — Dimension to be checked on Class C50 drawbar couplings

2.3 Class D50 drawbar eyes

The thickness of Class D50 drawbar eyes shall be checked on each side of the longitudinal median plane.

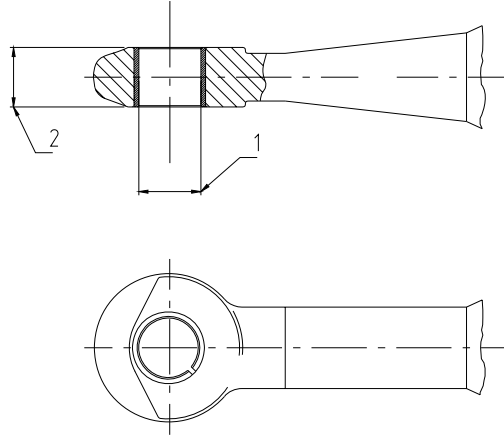

Key

- 1 dimension to be checked, eye bush
- 2 dimension to be checked, thickness

Figure 2 — Dimensions to be checked on Class D50 drawbar eyes

2.4 Class H50 fifth wheel kingpins

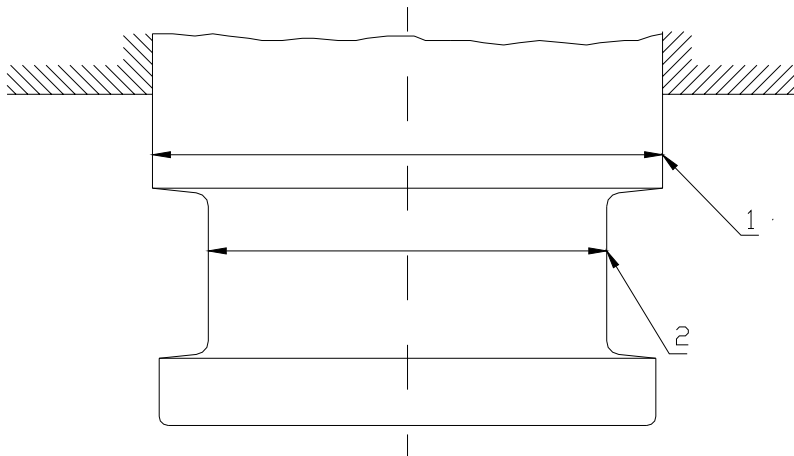

Key

- 1 dimension to be checked, upper diameter
- 2 dimension to be checked, inner diameter

Figure 3 — Dimensions to be checked on Class H50 fifth wheel kingpins

2.5 Class K hook couplings

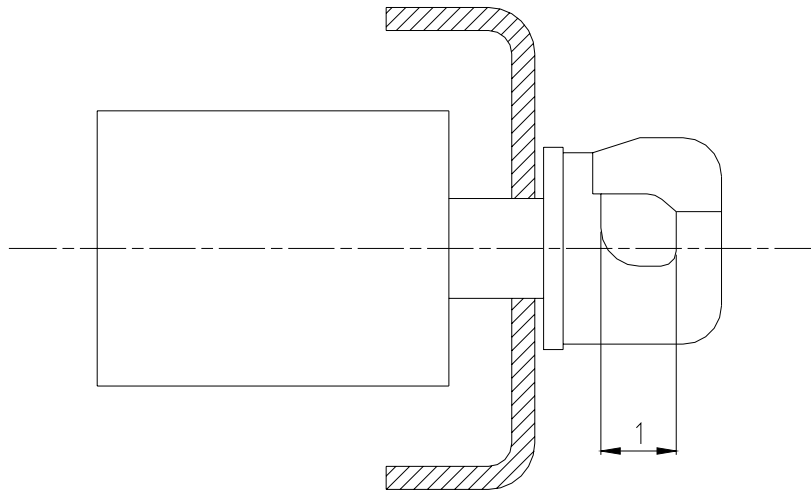

Key

- 1 dimension to be checked

Figure 4 — Dimension to be checked on Class K hook couplings

2.6 Class L toroidal eyes

The thickness of the foremost extremity of the torus shall be checked at the weakest spot of the torus section, which may be measured in any axis direction of the torus.

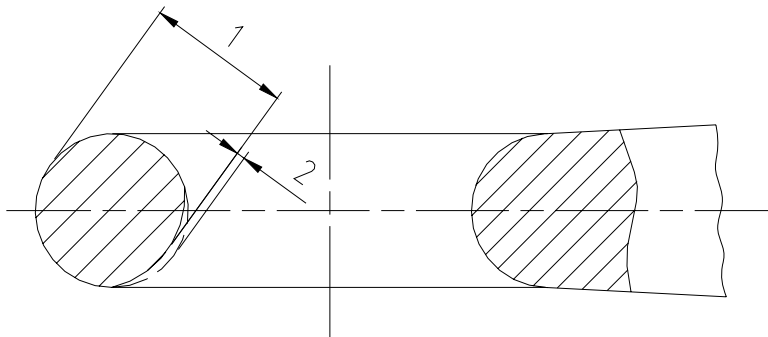

Key

- 1 dimension to be checked
2 wear

Figure 5 — Dimension to be checked on Class L toroidal eyes

3 Limits of the worn components

Table 1 — Limit dimensions for worn mechanical couplings

Dimensions in millimetres

Mechanical coupling	In-use limit dimension
Class C50 drawbar coupling, pin ^a	46,5 min.
Class D50 drawbar eye, bush ^b	51,5 max.
Class D50 drawbar eye, thickness ^c	41,5 min.
Class H50 fifth wheel kingpin, upper cylinder ^d	71 min.
Class H50 fifth wheel kingpin, median cylinder ^e	49 min.
Class K hook coupling ^f	49 max.
Class L toroidal eye ^g	37 min.

^a Outer diameter of the pin: standard design dimension is shown in Regulation UN-ECE No. 55, Revision 1, Figure 8, side view.

^b Inner diameter of the bush: standard design dimension is shown in Regulation UN-ECE No. 55, Revision 1, Figures 9 and 10.

^c Thickness of the eye: standard design dimension is shown in Regulation UN-ECE No. 55, Revision 1, Figure 11, side view.

^d Outer diameter of the upper cylinder: standard design dimension is shown in Regulation UN-ECE No. 55, Revision 1, Figure 18.

^e Outer diameter of the median cylinder: standard design dimension is shown in Regulation UN-ECE No. 55, Revision 1, Figure 18.

^f Inner longitudinal clearance of the hook: standard design dimension is shown in Regulation UN-ECE No. 55, Revision 1, Figure 19.

^g Outer diameter of the torus: standard design dimension is shown in Regulation UN-ECE No. 55, Revision 1, Figure 14.
