



**Economic and Social
Council**

Distr.
GENERAL

ECE/TRANS/WP.29/GRSP/2006/2
3 March 2006

Original: ENGLISH

ENGLISH AND FRENCH ONLY

ECONOMIC COMMISSION FOR EUROPE

INLAND TRANSPORT COMMITTEE

World Forum for Harmonization of Vehicle Regulations (WP.29)

Working Party on Passive Safety (GRSP)
(Thirty-ninth session, 15-19 May 2006,
agenda item A.1.)

**PROPOSAL FOR A GLOBAL TECHNICAL REGULATION ON
UNIFORM PROVISIONS CONCERNING THE APPROVAL OF VEHICLES WITH
REGARD TO THEIR CONSTRUCTION IN ORDER TO IMPROVE THE PROTECTION
AND MITIGATE THE SEVERITY OF INJURIES TO PEDESTRIANS AND OTHER
VULNERABLE ROAD USERS IN THE EVENT OF A COLLISION**

Transmitted by the informal working group on pedestrian safety

Note: The text reproduced below was prepared by the informal working group on pedestrian safety. It replaces TRANS/WP.29/GRSP/2005/3.

Note: This document is distributed to the Experts on Passive Safety only.

TABLE OF CONTENTS

A.	STATEMENT OF TECHNICAL RATIONALE AND JUSTIFICATION.....	3
B.	TEXT OF REGULATION.....	33
1.	PURPOSE AND SCOPE.....	33
2.	APPLICATION.....	33
3.	DEFINITIONS.....	33
4.	GENERAL REQUIREMENTS.....	43
4.1.	Legform test to bumper.....	43
4.1.1.	Lower legform to bumper.....	43
4.1.2.	Upper legform to bumper.....	43
4.2.	Child headform impact.....	43
4.3.	Adult headform impact.....	43
5.	PERFORMANCE REQUIREMENTS.....	43
5.1.	Legform to bumper.....	43
5.2.	Headform tests.....	44
6.	TEST SPECIFICATIONS.....	45
6.1.	General test conditions.....	45
6.2.	Preparation of the vehicle.....	46
6.3.	Test impactor specifications.....	46
6.3.1.	Legform impactors.....	46
6.3.2.	Child and adult headform impactors.....	51
7.	TEST PROCEDURES.....	55
7.1.	Legform to bumper test procedures.....	55
7.1.1.	Lower legform to bumper test procedure.....	55
7.1.2.	Upper legform to bumper test procedure.....	57
7.2.	Headform test procedures.....	57
7.3.	Child headform test procedure.....	58
7.4.	Adult headform test procedure.....	59
8.	CERTIFICATION OF IMPACTORS.....	59
8.1.	Lower legform impactor certification.....	60
8.2.	Upper legform impactor certification.....	62
8.3.	Child and adult headform impactors certification.....	64

A. STATEMENT OF TECHNICAL RATIONALE AND JUSTIFICATION

I. SAFETY NEED

Each year, thousands of pedestrians and cyclists are struck by motor vehicles. Most of these accidents take place in urban areas where serious or fatal injuries can be sustained at relatively low speed, particularly in the case of children. This global technical regulation (gtr) will significantly reduce the levels of injury sustained by pedestrians involved in frontal impacts with motor vehicles.

This gtr is based on data from a number of sources, including the International Harmonized Research Activities (IHRA)^{1/} Pedestrian Safety working group (IHRA/PS). The data was sourced from Australia, Germany, Japan and the United States of America. Data from IHRA ^{2/}, Germany ^{3/}, Italy ^{4/}, the UNECE ^{5/}, Spain ^{6/}, Canada ^{7/}, the Netherlands ^{8/}, Sweden ^{9/}, and Korea ^{10/} indicate that, annually: in the European Union about 8,000 pedestrians and cyclists are killed and about 300,000 injured; in North America approximately 5,000 pedestrians are killed and 85,000 injured; in Japan approximately 3,300 pedestrians and cyclists are killed and 27,000 seriously injured; and in Korea around 3,600 pedestrians are killed and 90,000 injured.

The IHRA/PS study indicates the following:

(a) Distribution of the Injuries

Comparing the ages of those involved, statistics show the highest frequency of accidents is for children of five to nine years old, and for adults over 60 years old. Children (aged 15 and under) account for nearly one-third of all injuries in the dataset, even though they constitute only 18 per cent of the population in the four countries included in the IHRA data.

The frequency of fatal and serious injuries (Abbreviated Injury Scale: AIS 2-6) is highest for the child and adult head and adult leg body regions (INF GR/PS/3).

^{1/} IHRA is an inter-governmental initiative that aims to facilitate greater harmony of vehicle safety policies through multi-national collaboration in research.

^{2/} A number of reference documents is listed in the Appendix to this global technical regulation. The documents are available on the UNECE WP.29 website at the address: <http://www.unece.org/trans/main/welcwp29.htm>.

IHRA data are set forth in working paper No. 3 of the informal group on pedestrian safety (INF GR/PS/3) at <http://www.unece.org/trans/doc/2002/wp29grsp/inf-gr-ps-3e.ppt#262,1>, 1st meeting of the Informal Group on Pedestrian Safety, and in working paper No. 31 (INF GR/PS/31).

^{3/} INF GR/PS/12, /13 and /25

^{4/} INF GR/PS/14

^{5/} INF GR/PS/15

^{6/} INF GR/PS/16

^{7/} INF GR/PS/20

^{8/} INF GR/PS/21

^{9/} INF GR/PS/41

^{10/} INF GR/PS/70

(b) Crash Speeds

Crash speeds between vehicles and pedestrians were collected from pedestrian accident data. The cumulative frequency of the crash speeds shows that a crash speed of up to 40 km/h can cover more than 75 per cent of total pedestrian injuries (AIS 1+) in all regions.

(c) Target Population for this gtr

The IHRA injury data indicate the injury distribution by body regions. Fatal and serious head injuries (AIS2+) of children and adults as well as AIS2+ adult leg injuries were extracted from the IHRA data base for clearly identified injury causing parts on the vehicle and on the road (INF GR/PS/131 and 169). It was found that hood/fender/bonnet/wing contacts caused 41 per cent of child head injuries of AIS2+ and 19 per cent of the adult AIS2+ head injuries. Bumper contacts lead to 64 per cent of adult AIS2+ leg injuries. The cumulative frequency curves versus vehicle impact speed for these injuries and their respective injury causing parts show that 58 per cent of the child head AIS2+ injuries are addressed to a vehicle impact speed up to 40 km/h, 40 per cent to adult head AIS2+ injuries and 50 per cent of the adult leg AIS2+ injuries respectively. Based on these figures of injuries by injury source and vehicle contact area, the target population of the above mentioned AIS2+ injuries for this proposed gtr is 24 per cent of child pedestrian head injuries, 8 per cent of adult pedestrian head injuries, and 32 per cent of adult leg injuries.

Each of these body regions, i.e. head of child/adult and adult leg, covers more than 30 per cent of total fatal and severe injuries (INF GR/PS/3). This gtr focuses on protecting these body regions.

The major source of child head injuries is the top surface of the bonnet/wing, while adult head injuries result from impacts to the top surface of bonnet/wing and windscreen area. For adult leg injuries, the major source is the front bumper of vehicles.

(d) Applicability to Motor Vehicle Categories

The maximum benefit from making vehicles pedestrian friendly would occur if all types of vehicles comply with these technical provisions, but it is recognized that their application to heavier vehicles (large trucks and buses) as well as to very small and light vehicles could be of limited value and may not be technically appropriate in their present form. The tests proposed in this gtr have been developed on the basis of current light vehicles, taking into account the pedestrian kinematics when impacted by such vehicles. For this reason, the scope of application is limited to passenger cars, sport utility vehicles (SUV), light trucks and other light commercial vehicles. Since these vehicle categories represent the vast majority of vehicles currently in use, the proposed measures will have the widest practicable effect in reducing pedestrian injuries.

II. SUMMARY: DESCRIPTION OF THE PROPOSED REGULATION

(a) Introduction

It is generally accepted that in the most representative pedestrian to car accident the pedestrian is in normal walking posture, meaning that the pedestrian is standing sideways to the vehicle, and is struck by the vehicle from the side. This scenario therefore is also the basis for this gtr.

When an adult pedestrian is struck by vehicles addressed by this gtr, the first impact is generally between the pedestrian knee region and the vehicle's front bumper. Because this initial contact is usually below the pedestrian's centre of gravity, the upper body in such a case begins to rotate toward the vehicle. The pedestrian's body accelerates linearly relative to the ground because the pedestrian is being carried along by the vehicle. The second contact usually is between the upper part of the grille or front edge of the bonnet and the pedestrian's pelvic area. The pedestrian's legs and pelvis have reached the linear velocity of the vehicle at this point and the upper body (head and thorax) are still rotating toward the vehicle. The final phase of the collision involves the head and thorax striking the vehicle with a linear velocity approaching that of the initial striking velocity of the vehicle. IHRA research has shown that the linear head impact velocity averages about 80 percent of the initial contact velocity.

Through the pedestrian accidents analysis, it has been concluded that child and adult heads and adult legs are the body regions to be most affected by contact with the front end of vehicles. On vehicles, the bumper, the bonnet top, the windscreen area including the A-pillars are the vehicle regions mostly identified with a high potential for contact. According to the IHRA/PS study, the above-mentioned areas can cover more than 65 per cent of the fatal and serious injuries.

Based on these study results, the informal group prioritized the development of approaches to simulate a pedestrian impact and encourage countermeasures that will improve pedestrian protection. This gtr would improve pedestrian safety by requiring vehicle bonnets and bumpers to absorb energy more efficiently when impacted in a 40 kilometre per hour (km/h) vehicle-to-pedestrian impact, which accounts for more than 75 per cent of the pedestrian injured accidents (AIS 1+) reported by IHRA/PS of the injury frequency.

During the activities of the gtr informal group, headform to windscreen testing was proposed to be included in the gtr. IHRA accident studies mentioned above identify the windscreen, windscreen frame and A-pillars as injury causing parts of the vehicle in pedestrian to car collisions.

After several intensive discussions on this issue the group decided not to include these kinds of tests into the gtr at this stage for the following reasons:

1. The group recognized that the A-pillars, windscreen roof and lower frames have to be very stiff vehicle parts due to their functional requirements. As an example in the lower windscreen area, the required deformation space to meet a head impact requirement is restricted by the instrument panel. Some components that are required to meet governmental safety standards, such as defrost/demist etc., make it impossible to lower the dashboard significantly. In addition, the structural components of the dashboard represent important load paths in front or side crashes. On the other hand, the entire windscreen frame would need to be softened extremely to pass any HIC (Head Injury Criterion) requirement. This strongly contradicts roll over requirements and other existing legal and consumer demands (see INF GR/PS/059 and INF GR/PS/035). In addition the group received detailed data showing that extremely high HIC measurements are frequently obtained in these difficult areas (see INF GR/PS/072, 094, 102 and 103) and agreed that there are no technical design solutions or countermeasures available so far to drastically reduce HIC levels.

2. The windscreen glass itself does not produce severe injuries and therefore the amount of saved casualties will be very low. The effectiveness of testing the windscreen inner part is seen as very questionable.
3. In addition, it was noted that vehicle manufacturers believed that there are problems related to scatter of HIC when performing tests in the windscreen and that the reasons for the scatter are not yet fully understood. (see INF GR/PS/134, 163 and 164).

However, some delegates expressed interest in having domestic regulations that apply head protection requirements to the windscreen area. The informal group did not believe the gtr would foreclose any jurisdiction from applying head protection requirements to the windscreen area by way of domestic regulations.

(b) Overview

This gtr consists of two sets of performance criteria applying to: (a) the bonnet top and wings; and (b) the front bumper. Test procedures have been developed for each region using sub-system impacts for adult and child head protection and adult leg protection 11/.

The head impact requirements will ensure that bonnet tops and wings will provide head protection when struck by a pedestrian. The bonnet top and wings would be impacted with a child headform and an adult headform at 35 kilometre per hour (km/h). The ~~Head Injury Criterion (HIC)~~HIC must not exceed 1,000 over one half of a child headform test area and must not exceed 1,000 over two thirds of a combined child and adult headform test areas. The HIC for the remaining areas must not exceed 1,700 for both headforms.

The leg protection requirements for the front bumper would require bumpers to subject pedestrians to lower impact forces. This gtr specifies that the vehicle bumper is struck at 40 km/h with a legform that simulates the impact response of an adult's leg. Vehicles with a lower bumper height of less than 425 millimetre (mm) are tested with a lower legform, while vehicles with a lower bumper height of more than 500 mm are tested with an upper legform test device. Vehicles with a lower bumper height between 425 mm and 500 mm are tested with either legform chosen by the manufacturer. In the lower legform to bumper test, vehicles must meet limits on lateral knee bending angle, knee shearing displacement, and lateral tibia acceleration. In the upper legform to bumper test, limits are placed on the instantaneous sum of the impact forces with respect to time and the bending moment on the test.

The performance requirements, test procedures and supplementary information explaining the rationale for this gtr are discussed in detail in later sections of this preamble.

11/ To develop these test procedures, the group carefully studied the availability of the pedestrian dummy as an alternative method for the test procedures. The group concluded that there is no test dummy presently available that could be considered suitable for regulatory use. Accordingly, the informal group decided to select subsystem test methods which are readily available, and which have the necessary reliability, repeatability and simplicity.

III. PROCEDURAL BACKGROUND

During the one-hundred-and-twenty-sixth session of WP.29 in March 2002, AC.3 concluded their considerations of priorities for developing future global technical regulations. WP.29 adopted the 1998 Global Agreement Programme of Work, which included pedestrian safety, and decided to start the work on pedestrian safety at the thirty-first session of GRSP in May 2002, by establishing an informal group to draft the gtr. The formal proposal to develop a gtr (TRANS/WP.29/AC.3/7) was considered and adopted by the AC.3 at its tenth session, in March 2004. It is based on document TRANS/WP.29/2004/26, which had been submitted by the European Community, which is the technical sponsor of the project.

Informal document No. 10 of the thirty-first session of GRSP lays down the terms of reference of the group and the document was adopted by GRSP (INF GR/PS/2).

Informal document No. 7 of the thirty-second session of GRSP reported on the result of the first meeting of the informal group (INF GR/PS/9).

Informal document No. 2 of the thirty-third session of GRSP (INF GR/PS/47 Rev1) was the first preliminary report of the informal group and responds to paragraph 5 of documents TRANS/WP.29/2002/24 and TRANS/WP.29/2002/49 as adopted by AC.3 and endorsed during the one-hundred-and-twenty-seventh session of WP.29. The documents were consolidated in the final document TRANS/WP.29/882. The preliminary report was adopted as TRANS/WP.29/2003/99 by AC.3 in November 2003.

Informal document No. GRSP-34-2 of the thirty-fourth session of GRSP reported on the action plan of the informal group (INF GR/PS/62).

Informal document No. GRSP-35-5 of the thirty-fifth session of GRSP was the second preliminary report of the informal group (INF GR/PS/86 Rev2 and PS/88). This report was considered by AC.3 in June 2004 as informal document No. WP.29-133-7.

Informal document No. GRSP-36-1 of the thirty-sixth session of GRSP was the first draft gtr of the informal group (INF GR/PS/116).

TRANS/WP.29/GRSP/2005/3 was proposed at the thirty-seventh session of GRSP and was a revised draft gtr including the preamble, of the informal group (INF GR/PS/117).

The group had held the following meetings:

- 4-5 September, 2002, Paris, [France](#)
- 10 December, 2002, Geneva, [Switzerland](#)
- 15-16 January, 2003, Santa Oliva, [Spain](#)
- 15-16 May, 2003, Tokyo, [Japan](#)
- 10-12 September, 2003, Ottawa, [Canada](#)
- 24-26 February, 2004, Paris, [France](#)
- 28-30 September, 2004, Paris, [France](#)
- 11-13 July, 2005, Brussels, [Belgium](#)
- 5-6 December, 2005, Geneva, [Switzerland](#)
- 16-19 January, 2006, Washington DC, [USA](#)

The meetings were attended by representatives of:

The Netherlands, France, Germany, Canada, European Community (EC), Spain, Japan, United States of America (US), Korea, Italy, Turkey, the European Enhanced Vehicle-safety Committee (EEVC) ^{12/}, Consumers International (CI), the European Association of Automotive Suppliers (CLEPA) and the International Organization of Motor Vehicle Manufacturers (OICA).

The meetings were chaired by Mr. Mizuno (Japan) and Mr. Friedel/Mr. Cesari (EC), while the secretariat was provided by Mr. Van der Plas (OICA).

IV. EXISTING REGULATIONS, DIRECTIVES, AND INTERNATIONAL VOLUNTARY STANDARDS

At the present time, there are no regulations concerning the provision of improved protection for pedestrians and other vulnerable road users in the Compendium of Candidates.

The following is a summary of national and regional legislation and of work in international forums:

The Japanese Government has established a regulation on pedestrian protection. The regulation addresses the issues of providing protection for the child and adult heads. It applies to passenger cars with up to 9 seats and to small trucks of up to 2,500 kg gross vehicle mass with application from 2005 for new vehicle types and from 2010 for existing vehicle types (certain other vehicles have a timetable which is postponed by two years). The regulation requires compliance with test requirements using representative head impactors.

The European Parliament and Council adopted the Directive 2003/102/EC which provides for the introduction of requirements for leg injuries, and adult and child head injuries. The Directive and its requirements are incorporated into Community legislation under the European Union (EU) whole vehicle type approval system set up by EU Framework Directive 70/156/EEC. It applies to passenger cars of category M₁ and to light commercial vehicles derived from passenger cars of M₁ category, both up to 2,500 kg gross vehicle mass, with application dates in two phases starting in 2005 and 2010. The requirements and the tests are based on the research results that were published by EEVC in the 1990's and that were introduced in a less severe form for the first phase and intended to be introduced in the originally proposed form for the second phase. However, since EEVC results never have been fully accepted by all involved parties, the Directive provided for a review of the feasibility of the requirements of the planned second phase in 2004. This feasibility review has taken place and ~~will~~^{may} result in ~~the~~ amendments to the European requirements in its second phase, starting in 2010.

Canada is currently reviewing its bumper regulation. The Canadian bumper regulation is one of the most stringent in the world (all the safety features of the vehicle have to be functional after

^{12/} The steering committee of the EEVC is composed of representatives from European national governments. The EEVC conducts research in motor vehicle safety and develops recommendations for test devices and procedures that governments can decide to adopt into national regulations.

an 8 km/h impact). In addition, Canada ~~is investigating~~ and USA are conducting preliminary investigation of the effect of bumper design on different leg test devices (TRL legform impactor; Polar dummy and flexible pedestrian legform impactor (Flex-PLI)).

The United States research programmes have addressed how vehicles could be modified to reduce the severity of head and leg impacts ^{13/} ^{14/}. The current US pedestrian protection research programme supports the IHRA objectives. Current activities include (1) pedestrian field data analysis to develop test conditions, (2) evaluation of pedestrian head and leg test tools, (3) experimental impact testing of vehicle structures to assess aggressivity, (4) pedestrian case reconstructions using a combination of field data, computer simulation, and testing to better understand injury mechanisms, (5) computer model development using available biomechanical literature, and (6) completion of other IHRA Pedestrian Safety Working Group action items.

The IHRA Pedestrian Safety working group has conducted detailed in-depth accident studies based on pedestrian accident data collected from the member countries. In addition this group carefully studied the front shape of passenger vehicles including SUVs, and used best available computer simulation model to study the effective head mass, adult and child head impacting speed during the impact with vehicles and the impact angles.

Based on these research results, the IHRA group developed test procedures and test devices for adult and child head protection and for adult leg protection.

~~[As a new step, the IHRA group is now considering the leg protection for high bumper vehicles. IHRA is researching an improved tool and test procedure for an upper legform to high bumper vehicle test. In addition, IHRA is researching an upper legform impactor to bonnet leading edge test. This is discussed in detail later in this preamble.]~~

The International Organization for Standardization (ISO) created the pedestrian protection working group (ISO/TC22/SC10/WG2) in 1987 to develop test methods for the reduction of serious injuries and fatalities for pedestrian to car accidents. The mandate for ISO/WG2 was to produce test methods, covering crash speeds up to 40 km/h, which will contribute to make cars pedestrian friendly. Since then, the WG2 has developed pedestrian test procedures and has described the necessary test tools. The study results were fully used in the IHRA/PS group, when IHRA/PS developed the adult and child impactors.

The ISO standards and draft standards are:

- ISO 11096 2002 Road vehicles - Pedestrian protection - Impact test method for pedestrian thigh, leg and knee,
- ISO/DIS 14514 Road vehicles - Pedestrian protection - Head impact test method,
- ISO/DIS 16850 Road vehicles - Pedestrian protection - Child head impact test method.

^{13/} Saul, R.A., Edlefson, J.F., Jarrett, K.L., Marcus, J.R.; "Vehicle Interactions with Pedestrians," Accidental Injury: Biomechanics and Prevention, New York: Springer-Verlag, 2002.

^{14/} "Report to Congress: Pedestrian Injury Reduction Research," NHTSA Report DOT HS 808 026, June 1993.

V. GENERAL ISSUES

(a) Scope

From the review of pedestrian fatality and injury statistics from several countries, it was shown that the head and the legs are the most frequently injured body regions in pedestrian accidents. It was recommended that the gtr would encompass tests for the adult head and leg, and the child head. It was also shown by these studies that the majority of pedestrian injuries are occurring in urban environments; therefore the gtr should test those vehicles found in this environment, including passenger vehicles, vans, and light trucks.

As suggested by the terms of reference of the informal group, consideration was given to the use of the best available technology and improvements in technology that will provide significant steps in developing methods and in achieving and improving benefits, including both active and passive safety measures (TRANS/WP.29/GRSP/30). There was discussion on whether the proposed pedestrian gtr should regulate passive and/or active safety systems. Active safety systems such as brake assist, anti-lock brakes and day-light running lights were suggested as solutions for the reduction of pedestrian injuries, but it was ultimately counselled by GRSP and WP.29 to concentrate on passive systems for this gtr, as this is the main domain of expertise of the GRSP working party, and only to provide advice on the use of active systems.

The group understood that active safety and infrastructure measures were not within the remit of the group, but determined that it could be useful and efficient to inform WP.29/AC.3 as well as other authorities of the need to take these issues into account for real world safety improvements. The group also noted the importance of educational measures as well as the need to enforce existing road traffic legislation. Some experts noted that consideration of other safety measures, if properly balanced with the passive safety requirements, might help in ensuring that the vehicle passive safety requirements are kept at a realistic and feasible level.

OICA, in particular, mentioned brake assist systems which can, in emergency situations, substantially improve the braking performance and consequently reduce the impact speed when the impact is unavoidable. A study on the effectiveness of such a system was presented by OICA using the German In-Depth Accident Studies (GIDAS) database (INF GR/PS/25). This showed that if the vehicle speed is 50 km/h at the start of braking, the collision speed (car versus pedestrian) would be reduced to 40 km/h in general, to 35 km/h for an experienced driver and to 25 km/h for cars equipped with brake assist systems. Another study performed by the Technical University of Dresden on behalf of ACEA was presented by OICA (INF GR/PS/92). This study confirmed the positive effect of brake assist systems on pedestrian fatalities and injuries.

As for infrastructure measures that could improve pedestrian safety, OICA presented the results of a 1998 study conducted on behalf of ACEA by the consultants ORIENTATIONS (France) and TMS Consultancy (United Kingdom) (INF GR/PS/29). This study, which evaluated the effect of infrastructural measures based on real data evaluations, concluded that such measures could dramatically reduce the number of pedestrian victims (fatalities/injuries) at low cost.

(b) Applicability

The application of the requirements of this gtr refers, to the extent possible, to the revised vehicle classification and definitions outlined in the 1998 Global Agreement Special Resolution No. 1 concerning the common definitions of vehicle categories, masses and dimensions (S.R.1).

Difficulties, due to differing existing regulations and divergent vehicle fleets, were encountered in determining which vehicles would be included in the scope. The Japanese regulation applies to passenger cars for up to nine occupants and commercial vehicles up to a Gross Vehicle Mass (GVM) of 2.5 tonnes. The IHRA recommends tests and procedures for passenger vehicles of GVM 2.5 tonnes or less. The European Union (EU) Directive applies to M₁ vehicles up to 2.5 tonnes and N₁ vehicles up to 2.5 tonnes, which are derived from M₁. The ISO recommendations are for M₁ and N₁ vehicles that have a GVM of 3.5 tonnes or less. In addition, some countries, taking into account their current fleet composition, considered that care should be taken not to exclude from the requirements too large a number of vehicles, such as light trucks and sport utility vehicles.

The group originally reviewed in detail the IHRA recommendation to take into account the shape of the front of the vehicle, as an important parameter when discussing the types of pedestrian injuries to be mitigated. IHRA specifies three groups of vehicle shape: sedan, SUV, and 1-box. For the adult and head impacts, IHRA foresees different impact test speeds and different impact angles. The Japanese legislation is based on the IHRA recommended method. The EU requirements, on the contrary, do not differentiate between the various test speeds and impact angles.

The group compared these various considerations and, on the basis of simulations (INF GR/PS/129), concluded that the EU requirements in effect are more severe than the Japanese proposals. For safety reasons, the group therefore uses the EU approach, not taking into account the shape of the vehicle front in defining the requirements. Furthermore, the group also determined that the IHRA recommendations would be difficult to put in place in the context of a regulatory and certification approach.

There was considerable discussion over the mass of the vehicles to which this gtr should apply. Using the categories described in S.R.1, there were several options examined. It was agreed that as a minimum the gtr should apply to all vehicles in Category 1-1 with a vehicle mass of less than 2.5 tonnes GVM, but more than 500 kg. An argument for the 2.5 tonnes GVM maximum limit is that all existing tests were only validated for (previously conducted on) vehicles up to 2.5 tonnes GVM. However, since some Category 1-1 vehicles weigh more than 2.5 tonnes GVM, some delegates argued that the gtr should be applicable to vehicles that weigh up to 3 or 3.5 tonnes GVM. These delegates argued that the front-end structure of these heavier vehicles usually is similar to lighter vehicles; therefore the application of the requirements should be the same.

The group confirmed its intention to include a maximum of vehicles representative of the current vehicle fleets worldwide, taking however into account their involvement in pedestrian accidents, the technical feasibility and cost/benefit considerations. In particular, it was recognised that the proposed tests are only validated up to a gross vehicle mass of 2,500 kg. The group also recognised that a large proportion of current light trucks and sport utility vehicles would fall in

the proposed category 1-1 below 2.5 tonnes; heavier vehicles of category 1-1 only constitute a small portion of the vehicle fleet.

In some jurisdictions, lighter vehicles, which are included in the definition of category 1-1, are classified as other than either passenger cars or cargo vehicles. These are presently classified as categories L₆ and L₇ under the 1958 Agreement and are normally either four-wheel motorcycles (quads) or very light small local delivery units (such as buggies). To ensure that these four-wheel units, which are capable in some cases of carrying a passenger, are not unduly required to undergo tests which are considered neither practical for the unit concerned, nor useful in terms of overall benefit, may not be included in the application of this gtr it is necessary to provide a lower limit of vehicle weight below which the requirements would not apply. This limit is set at 500 kg with respect to these vehicles.

It was therefore agreed that the gtr would apply to all Category 1-1 vehicles with a gross vehicle mass exceeding 500 kg but not exceeding 2.5 tonnes and if a jurisdiction determines that its domestic regulatory scheme is such that limited applicability is inappropriate, it may extend domestic regulation to other Category 1-1 vehicles. The Contracting Party will have to provide reasonable justification regarding the applicability and the necessary validation tests to prove that current test procedures and limits are applicable to vehicles outside the weight limits specified in this gtr.

Many vehicles in Category 2 are manufactured on the same platform as vehicles in Category 1-1 and have the same or similar front-end shapes. The group considered that these vehicles should be included in the proposed gtr, but noted the difficulty in defining this group of vehicles. The group agreed that this should include vehicles which forward of the A-pillars, the general structure and the shape are the same. This would, as an example, be the case of a light truck built on the same platform and with the same front-end shape as a passenger car or SUV.

As for vehicles of Category 1-1, the group agreed to limit the application to those Category 2 vehicles with a Gross Vehicle Mass above 500 kg but below 2.5 tonnes, yet if a jurisdiction determines that its domestic regulatory scheme is such that limited applicability is inappropriate, it may extend domestic regulation to other Category 2 vehicles provided that justification regarding the applicability of the requirements is offered.

The tests in this proposed gtr are all considered to be technically and economically feasible as outlined in this preamble. However, it will be the decision of each jurisdiction to determine whether the benefits achieved by requiring these tests justify the costs. Based on this determination, a jurisdiction can choose to further limit the application in their own regulation to specific vehicle categories and/or it may decide to phase in the regulations over time.

(c) Implementation Generally

The informal group considers all tests in this proposed gtr to be technically feasible and able to evaluate objectively the ability of vehicle bonnets and bumpers to absorb energy more efficiently. However, pedestrian accident crash characteristics and vehicle baseline performance may differ regionally. It will be the decision of each jurisdiction to determine whether the benefits achieved by requiring these tests justify the costs. Based on this determination, a jurisdiction can choose to limit the application in its own regulation to specific vehicle

categories, specific tests, and/or it may decide to phase in the regulations over time.

(d) Future Consideration

During the discussions, it became clear that some issues could not be fully resolved within the timeframe of the terms of reference for the informal group. The group determined that the following issues should be considered further beyond this gtr.

1. Lower legform impactor

The lower legform impactor currently used for testing in Europe was designed by the Transport Research Laboratory (TRL) in the United Kingdom. However, it is known to also have certain limitations regarding the biofidelity and the repeatability of the test results. Therefore, Japan proposed to use a completely new legform, the so-called Flexible Pedestrian Legform Impactor (FlexPLI). As the FlexPLI legform is considered by some to have high biofidelity and an excellent ability to assess potential leg injuries, the FlexPLI should be considered to replace the TRL lower legform impactor in the future. However, because of the lack of experience in using the FlexPLI as a certification tool, a further confirmation process is needed. Therefore, a Technical Evaluation Group (TEG) was established to evaluate the reliability of the FlexPLI as a certification tool (TRANS/WP.29/GRSP/36). The TEG is currently assessing the FlexPLI and will advise GRSP by the end of 2007 as to the suitability of the FlexPLI for testing and compliance verification purposes (TRANS/WP.29/GRSP/37). The TEG is also expected to provide its recommendation as to the effective date of entry into force and the date on which the FlexPLI could replace the rigid lower legform impactor. TEG will also consider a transitional period during which the FlexPLI and the rigid lower legform impactor can be used as alternatives.

2. Upper legform impactor to high bumper test

Some delegates had concerns about the biofidelity of the upper legform impactor and the limitations of the test tool in assessing injury. IHRA/PS is working on recommendations for an improved upper legform impactor for possible future use.

3. Upper legform impactor to bonnet leading edge test

Several accident studies from some regions comparing modern "streamline" vehicle fronts registered in or after 1990 and old vehicles from the eighties or seventies indicate a decrease in AIS 2+ upper leg and pelvis injuries caused by the bonnet leading edge. The accident studies were performed by the LAB using French data (INF GR/PS/30), and by the University of Dresden using German GIDAS data (INF GR/PS/92). In addition, EEVC WG17 summarized in their 1998 report that no serious (AIS 2+) upper leg or pelvis injuries caused by the bonnet leading edge were found for post-1990 car models impacting a pedestrian at a speed up to 40 km/h (INF GR/PS/187 Rev.1). In contrast, data from the United States of America indicate a high incidence of above-the-knee injuries due to the prevalence of light trucks and vans in the United States fleet, and that consideration should be given to evaluating thigh, hip, and pelvis injuries in future test procedures.

Despite the desire to address any potential injuries in the upper leg or pelvic area, the group was

also concerned that there was a serious lack of biofidelity for the existing test device and the respective test procedure to assess injury caused by the bonnet leading edge of high profile vehicles. Therefore, the group recommended excluding the upper legform impactor to bonnet leading edge test at this stage. IHRA/PS is carrying out further research into an improved impactor and test procedures for this test.

VI. PEDESTRIAN HEAD PROTECTION

IHRA data show that a major source of child and adult pedestrian head injuries is the top surface of the bonnet/wing of the striking vehicle. As explained in this section, this gtr requires the bonnet/wing to perform at levels that decrease the likelihood that head impact with the bonnet/wing in a 40 kilometre per hour (km/h) pedestrian-to-vehicle impact will result in fatal or serious injury.

The bonnet/wing would be impacted with a headform at 35 km/h. The bonnet/wing would be divided into a "child headform test area" and an "adult headform test area". The child headform test area is the area of the bonnet/wing that is likely to be impacted by the head of a 6-year-old child in a pedestrian impact. A child headform is used to evaluate the bonnet/wing in that area. Likewise, the adult headform test area corresponds to the area of the bonnet/wing that the head of a mid-size adult male pedestrian is likely to impact. An adult headform is used to test the bonnet/wing in the latter area.

(a) Test Areas

The bonnet top is an area bounded by reference lines corresponding to the bonnet leading edge, the sides of the vehicle, and the rear of the bonnet (all terms are objectively defined in this gtr). The gtr divides the bonnet top into test areas using a parameter called the "wrap around distance" (WAD). The WAD is the distance from a point on the ground directly below the bumper's leading edge to a designated point on the bonnet, as measured with a flexible device, such as a cloth tape measure. A WAD of a specified distance, measured as described in the gtr, defines points on the vehicle's bonnet from which test areas can be determined.

The WAD is a good indicator of where head impacts are likely to occur on the bonnet. Head impact locations on the bonnet are largely explained by the standing height of the pedestrian and the frontal geometry of the striking vehicle. The WAD measurement is based on both pedestrian height and vehicle configuration. By use of the WAD, it can reasonably be estimated where on a vehicle a child or adult pedestrian's head may impact.

The WAD boundaries were selected based in large part on accident data from Australia, Europe, Japan and the United States of America of areas commonly struck by the head of a child and adult pedestrian. They were also selected considering the technical feasibility of regulating within a test area. The child headform test area is bounded in the front by a boundary determined by a WAD of 1,000 mm, and at the rear by a WAD of 1,700 mm line. A WAD of 1,000 mm was selected for the front boundary of the child headform test area because accident data show that most child pedestrian head contacts are above a WAD of 1,000 mm. Discussion also took place on possibly using a WAD of 900 mm. However, it was concluded that for many vehicles, a WAD of 900 mm would be located in the headlamp assembly area, where there would be feasibility problems in meeting the head protection requirements of this gtr.

Based on accident studies of adult pedestrian head impacts to the bonnet area, the adult headform test area begins in the front at a wraparound distance of 1,700 mm, and ends at the rear with a boundary determined by a WAD of 2,100 mm (or the rear edge of the bonnet for shorter vehicles). The child and adult headform test zones cover approximately 62 percent of the pedestrian cases (United States of America). Although 35 percent of the cases (United States of America) occurred at WADs exceeding 2,100 mm, many of these occurred in impacts greater than 40 km/h. (Three percent occurred below WAD 1,000). An overlap area was also considered with a WAD of 1,400 mm to 1,700 mm, where both adults and children have received head injuries in actual accidents. However, a defined boundary at 1,700 mm was determined to be more suitable, because little difference in the life-saving rate was perceived between the two approaches and because the boundary method provided a clearer approach.

(b) Points Tested

As head injuries to both adults and children occur throughout a wide range of areas at the front of the vehicle, subsystem tests using the adult and child headform impactors are appropriate to evaluate the bonnet top ~~and windscreen~~.

The informal group considered whether to specify both the number of test points and the minimum spacing of such test points. On consideration, the group determined that the specification of such points did not have a place within this proposed gtr for the following reasons:

1. For governments that use~~d~~ a self-certification regulatory framework, it was not considered necessary to mention the number of tests required for head impact testing or their spacing, as it would be incumbent on vehicle manufacturers to ensure that vehicles comply with all the impact zone requirements defined within this proposed gtr when tested by the regulating authority.
2. For type approval, the number of tests that need to be carried out to satisfy the relevant authority that vehicles meet the requirements is an issue for that authority, which may specify the number of tests and the spacing between the test points.
3. The mention of a minimum number of tests or a minimum distance apart between tests could result in manufacturers being burdened with unnecessary tests and/or authorities being unnecessarily restricted in test programs, as it would be difficult to set a target that would encompass both the largest and smallest test zones, and the situation could arise where test zones could be smaller than the minimum number of tests~~s~~ required that could be fitted into that zone.

(c) Head Injury Criterion

The majority of pedestrian fatalities in road accidents are caused by head injuries. The informal group determined that the head protection performance should be based on the Head Injury Criterion (HIC) 15/, given the ability of HIC to estimate the risk of serious to fatal head injury in

15/ The resultant acceleration at the location of the accelerometer mounted in the headform will be limited such that, for any two points in time, t_1 and t_2 , during the event which are

motor vehicle crashes. An HIC value of 1,000 is equivalent to approximately a 15 per cent risk of AIS 4+ head injury.

The gtr specifies that HIC must not exceed 1,000 over one half of the child headform test area and must not exceed 1,000 over two thirds of the combined child and adult headform test areas. The HIC for the remaining areas must not exceed 1,700 for both headforms. (The need for "relaxation zones," in which the HIC limit is 1,700, is discussed in the next section of this preamble).

HIC would be calculated within a 15 ms interval. The main reason that a longer interval was not used was that head impacts to external car structures are very short, occurring within a few milliseconds of contact. As the pulse itself is so short in time, there is no risk to lose part of the pulse during the HIC calculation--and no risk of a lower calculated HIC value--if a 15 ms interval were used rather than a longer interval (INF GR/PS/168). Accordingly, using either a 15 ms or a 36 ms pulse window will provide the same HIC value. Moreover, the test is not intended to record more than one impact. A short time duration avoids the risk that a second impact could be recorded after rebound. A longer duration for the time interval could result in distortions in the data recorded by the headform, which may lead to inaccurate HIC values.

(d) Relaxation Zones

Within the child and adult headform test areas are "relaxation zones" in which the HIC threshold is 1,700 instead of 1,000. Virtually all bonnets have hard substructures (e.g., shock struts) beneath them that prevent attainment of a 1,000 HIC performance criterion at all areas within the test area. The feasibility study detailed in INF GR/PS/91 and 101 showed the problem areas on the bonnet. Also, the feasibility study conducted on behalf of the European Commission (INF GR/PS/89) acknowledged the need to define an area on the bonnet for which a higher HIC limit is needed. As the problems on the bonnet are not the same for every vehicle model, it was felt necessary to set a maximum area with relaxed requirements that could be defined for every vehicle by the manufacturer.

The informal group considered the feasibility of applying the relaxation zone separately for the child and adult headform test areas, i.e., applying an HIC 1700 limit to a maximum of one third of the child test zone. It was determined that, because the location of necessary under-bonnet components, such as locks and suspension towers, cannot be fundamentally changed; they need to be located in the child headform test area. For vehicle types with small child headform test areas, the under bonnet components which are essential for functionality will be located in this

separated by not more than a 15 millisecond time interval and where t_1 is less than t_2 , the maximum calculated head injury criterion (HIC) shall not exceed 1,000, determined using the resultant head acceleration at the centre of gravity of the headform, a_r , expressed as a multiple of g (the acceleration of gravity), calculated using the expression:

$$\text{HIC} = \left[\frac{1}{(t_2 - t_1)} \int_{t_1}^{t_2} a dt \right]^{2.5} (t_2 - t_1)$$

test area. As a result, the relaxation zone for the child headform test area may be greater than one third of the zone (see illustrations 1 and 2 of INF GR/PS/158) 16/.

The relaxed value of 1,700 HIC was the subject of much discussion within the informal group. It was noted that IHRA/PS recognized the technical infeasibility of a headform test area without a relaxation zone with a HIC of more than 1,000 (INF GR/PS/5). The group also considered that current regulations in Japan and Europe, as enforced since 2005, limit the HIC in the relaxation zone to 2000. Although the European legislation also defines a Phase 2, beginning in 2010 and containing the original EEVC WG17 requirements, that does not allow any relaxation in the headform test area, the European legislation has provided for a review of the Phase 2 requirements. This review is ongoing, and has led to the conclusion that the Phase 2 requirements (that specify no relaxation zone) are technically infeasible (INF GR/PS/89, 91, 92 and 120). The European legislation also requires any new requirements replacing the existing ones to be more effective than those proposed by the EEVC WG17. The feasibility study performed on behalf of the European Commission (INF GR/PS/120) has determined that, among other requirements, a HIC of 1,700 in the relaxation zone not only represents the maximum achievable criterion, but will also lead to higher effectiveness, taking also into account feasibility aspects, whereas HIC values of less than 1,700 would bring back the feasibility problems. The group therefore decided to adopt the most demanding and maximum achievable criterion for the relaxation zone, a HIC of 1,700.

(e) Headform

A child headform is used to test the bonnet in the child headform test area, and an adult headform is used in the adult headform test area. The appropriate headform impactor size and mass, determined based on the characteristics of the human body, are explained below (INF GR/PS/46, 74 and 93).

1. Headform Diameter

The diameter of the child headform is 165 mm. Due to the fact that the majority of child pedestrian victims are 5 or 6 years old, this value was determined based on the average head diameter of a 6-year-old child (by averaging the diameter obtained from the circumference of the head and the longitudinal and lateral measurements of the head).

The diameter of the adult headform is 165 mm, which is the same diameter used in the test procedures of EEVC and ISO. The value was considered to represent the diameter mainly of the forehead portion of the 50th percentile adult male, rather than the maximum outer diameter of the head. The average height and weight of all adult pedestrian victims in the IHRA dataset is about the same as those of the 50th percentile male.

Thus the diameter of both the child and adult headforms is 165 mm. Although the diameter is different from the diameter of actual child and adult human heads, the diameter and moment of

16/ While the example in working paper INF GR/PS/158 shows a needed relaxation zone of around 40 per cent in the child headform test area, the example represents only one vehicle. The informal group determined that a maximum 50 per cent relaxation area in the child headform test area is a reasonable approach taking into account all envisaged vehicle types.

inertia are appropriately designed such that the child and adult headforms can properly estimate severity of injury to actual child and adult human heads (see IHRA/PS N231).

Testing experience with the headforms show them to be highly repeatable and reproducible.

2. Headform Mass and Moment of Inertia

Computer simulations conducted in the IHRA study show that the effective mass of the head in an impact with vehicles is identical to the actual mass of the head. Accordingly, the headform mass was therefore determined as follows:

- The mass of the child headform is 3.5 kilograms (kg), representing the mass of the head of a 6-year-old child.
- The mass of the adult headform is 4.5 kg, representing the mass of the head of a 50th percentile adult male.

This proposed gtr specifies the moment of inertia of the child and adult headforms as analyzed by IHRA (INF GR/PS/177) based on the EEVC/WG17 proposal (INF GR/PS/148) and the Japanese proposal (INF GR/PS/149). The IHRA proposal is 0.0084 – 0.0102 kgm² for the child headform and 0.0103 – 0.0127 kgm² for the adult headform. The informal working group on pedestrian safety adopted the proposal using the following rounded numbers: 0.008 – 0.010 kgm² for the child headform and 0.010 – 0.013 kgm² for the adult headform at the tenth informal meeting. Some members wanted to check these new limits and, after that meeting, it was revealed the above moment of inertia requirement is difficult to achieve for a child headform impactor which is developed in Europe. Therefore, the informal group slightly adjusted the upper limit for the child head impactor and finally adopted following values for the gtr headform impactors: 0.008 – 0.012 kgm² for the child headform and 0.010 – 0.013 kgm² for the adult headform.

3. Headform Accelerometer

This proposed gtr recommends a damped accelerometer (as specified in INF GR/PS/133) in the adult and child headform impactors. As explained in [working paper](#) INF GR/PS/96, in a research program in 2002 using the Japanese New Car Assessment Program (J-NCAP) headform test with undamped accelerometers, abnormal acceleration signals with high HIC values were recorded frequently in windshield impacts, and also in bonnet impacts. It was determined that this was due to the resonance vibration of the undamped accelerometer, which would occur if the spectrum of the impact waveform was near to the resonance frequency of the accelerometer. Once a high resonance, over the CAC setting level, occurs, it has a high chance to deform the acceleration waveform, i.e. one cannot obtain a correct acceleration waveform from the undamped accelerometer.

(f) Headform Test Speed and Angle

The head impact conditions (speed and angle) were considered together. The head impact test is representative of a vehicle-to-pedestrian impact at 40 km/h.

The gtr specifies that the child headform impacts the bonnet top at 35 km/h at an angle of 50 degrees to the horizontal. The adult headform impacts the bonnet at 35 km/h at a 65 degree angle.

In determining test speeds and angles of impact, the informal group considered the findings of IHRA and the EEVC. IHRA had explored whether various vehicle shapes influenced the angle at which a pedestrian's head impacted the bonnet top. Computer simulations were conducted, as part of the IHRA study, by the Japan Automobile Research Institute (JARI), the United States National Highway Traffic Safety Administration (NHTSA), and the Road Accident Research Unit of Adelaide University (RARU). The simulations used a 50th percentile adult male model and a 6-year-old child model. The distribution of headform impact speeds and angles in various impacts was obtained by simulating head impacts using three types of walking positions, three types of vehicle frontal shapes and two types of bonnet stiffness as parameters. The studies showed that the same headform impact speed could be used for any type of vehicle frontal shape. Further, the interpretation of the results indicated an average speed of 32 km/h, which is 0.8 times the vehicle impact speed of 40 km/h. In addition, various angles for adult and child impact conditions and for the three different shapes were defined as well.

In contrast, EEVC had concluded that one set of angles (50 degrees for the child headform test and 65 degrees for the adult headform test) for all vehicles is reasonable, simplifying any head test procedure dramatically. EEVC's decisions concerning head impact angles for child and adult tests were based on two reports used as working documents: Glaeser K.P. (1991), "Development of a Head Impact Test Procedure for Pedestrian Protection," BAST Report under contract N° ETD/89/7750/M1/28 to the E.C. (INF GR/PS/150); and Janssen E.G., Nieboer J.J. (1990), "Protection of vulnerable road users in the event of a collision with a passenger car, part 1 – computer simulations," TNO Report N° 75405002/1.

The EEVC values were based on post-mortem human subject (PMHS) tests and simulation results. The PMHS tests indicated a peak of the distribution of adult head impact angles to be 60 degrees, with all the results falling between 50° and 80°. Simulations gave a result around 67 degrees for adults, and indicated that vehicle shape had little influence on the angle of impact. EEVC chose a value of 65 degrees, which was close to the 67 degree angle resulting from the simulation and to the average of the PMHS results.

For child head impacts, EEVC considered simulations of a small adult female (close in anthropometry to a 12-year-old child) and of a 6-year-old child. Results of the small adult female simulations were very close to the results of the simulations for the 50th percentile male adult, while the simulations involving the 6-year-old child suggested a value around 50 degrees. EEVC picked the value of 50 degrees, believing that the simulations of a 6-year-old child were more relevant than those of a 12-year-old child for child pedestrian protection.

The informal group noted that the one set of angles from EEVC involves a different (higher) impact speed than that specified by IHRA. The group considered which of the two approaches of EEVC and IHRA was most stringent and thus offering of the most protection to pedestrians. Working paper INF GR/PS/129 showed, by both numerical calculation and by simulation, that the set of requirements defined by EEVC is more severe than the requirements defined by IHRA. The group thus decided to use the EEVC 50 degrees and 65 ~~degrees~~ impact angle for

child and adult head testing while maintaining the higher EEVC impact speed to the bonnet of 35 km/h (compared to the IHRA speed of 32 km/h).

VII. PEDESTRIAN LEG PROTECTION

(a) General

1. Purpose

This proposed gtr would specify minimum performance requirements for vehicle bumpers to provide leg protection by subjecting pedestrians to lower impact forces. As the majority of victims of leg injuries are adults, this proposed gtr specifies use of a legform impactor that simulates the leg of a mid-size adult male. The performance of the bumper would be evaluated by impacting the bumper with either of the two legforms, a lower legform impactor or an upper legform impactor, depending on the height of the bumper. The impact speed for both legform tests is the same as that of the striking vehicle in a 40 km/h impact, and thus determined to be 40 km/h.

The lower legform impactor is used to test vehicles with low bumpers, i.e., bumpers of heights less than 425 mm to a reference line on the lower surface of the bumper. The large majority of current passenger cars of the sedan type, as well as monospace (mini-van) type vehicles, have a lower bumper height around 200 to 250 mm above the ground. Therefore, these vehicles will be tested using the lower legform test procedure. Upper legform to bumper tests shall be carried out if the lower bumper height is more than 500 mm, typically represented by vehicles with off-road capabilities (SUVs). For vehicles that have a lower bumper height between 425 mm and 500 mm, the vehicle manufacturer can elect to perform either a lower legform test or an upper legform test.

2. Rationale for Limiting the Lower Legform Test

The reason that the lower legform test would not be applied to certain vehicles is due to the height limitations of the impactor, and the feasibility limitations of high-bumper vehicles to meet the test. The contact point between impactor and bumper should be below the knee, due to the impactor's structure and characteristics 17/. The EEVC WG17 states in its report, paragraph 7.2.1. (see also working paper INF GR/PS/159):

Some vehicles, like off-road vehicles, have high bumpers for certain functional reasons. These high bumpers will impact the femur part of the legform impactor, where no acceleration is measured to assess the risk of fractures. Moreover, there is often no structure below the bumper to restrain the tibia part of the legform, for instance because an off-road vehicle needs a certain ramp angle and ground clearance. Therefore WG17 decided to include an optional, alternative horizontal

17/ There is also a concern that the lower leg test could readily be met by simply allowing the lower legform to slide and/or rotate beneath the high bumper. This could have an unintended consequence of encouraging high bumpers as a way to meet the requirements, and lead to more pedestrian injury due to run-over.

upper legform test with an impact speed of 40 km/h, when the lower bumper height is more than 500 mm above the ground.

The informal group concurs with the determination of WG17 that the lower leg impactor test would be inappropriate for vehicles with high bumpers 18/.

At the same time, the informal group believes that high bumpers should be more energy absorbing, and for that reason adopts in this gtr the upper legform test for vehicles with a lower bumper height of more than 500 mm.

For vehicles that have a lower bumper height between 425 mm and 500 mm, the gtr provides that the vehicle manufacturer can elect to perform either a lower legform test or an upper legform test. Investigations conducted with vehicles with lower bumper heights between 400 and 500 mm indicate that a large majority of these vehicles have features for off-road capability. For these off-road vehicles, it is technically not feasible to have a countermeasure that will enable the vehicle to support the tibia part of the lower legform. That is, data show (see INF GR/PS/175/Rev.2) that the absence of a lower structure to support the lower part of the leg, due to the necessary off road capacities, make it very difficult for these vehicles to meet the proposed lower leg criteria, especially the bending angle. Therefore, the group ~~has agreed~~ **recommends** to use the upper legform to bumper test as an optional alternative to the lower legform to bumper test for these vehicles.

The group recognizes that excluding vehicles from the lower legform test will affect the target population of a lower extremity pedestrian regulation, and will reduce the benefits of the leg protection requirements, particularly with regard to knee injuries.

3. Handling Procedures

Delegates to the informal group were concerned about the effects of humidity on the **Confor™** foam flesh used in the legforms, recognizing that the **Confor™** material can vary significantly in performance depending on the humidity to which it is exposed. These concerns are addressed by specific controls in the regulatory text of this gtr regarding the humidity and other conditions (such as soaking time and a maximum time between removal from the soaking room and testing) under which the legform tests should be performed.

In addition, the group noted that legforms must also be carefully handled, as handling of the legform can affect variability in the bending angle, shearing displacement, and acceleration measured by the impactors due to the **Confor™** sensitivity to humidity. The group believed that handling instructions generally were not necessary to be specified in the gtr text, because the impactors are usually provided with handling instructions, which are the normal working tools for test houses and are therefore believed to be sufficient to cover the normal handling

18/ WG17 stated that the alternative legform test should be available for vehicles with a lower bumper height of more than 500 mm. However, WG17 referenced a value that WG10 had associated with the upper (rather than lower) bumper reference line. Also, since pedestrians are usually wearing shoes, the bottom of the legform impactor was determined to be 25 mm above the ground, the same height as the sole of a shoe (INF GR/PS/98). Accordingly, the informal group believes that the value of 425 mm (not 500 mm), measured to the lower bumper reference line is consistent with WG17's provision.

procedures. Nonetheless, the informal group emphasized that careful and controlled handling procedures, such as those developed by the German Federal Highway Research Institute BASt (INF [GR/PS/154/Rev.1](#)), are highly important to ensure reliable test results.

(b) Lower Legform Test

1. Impactor

It was agreed to ~~use~~[recommend using](#) the legform impactor developed by TRL, for the time being, to evaluate the performance of vehicles in protecting the lower leg. However, it was also ~~agreed~~[recommended](#) to consider the possible future use of the Flex-PLI, which is considered by some to be more biofidelic and expected to be highly usable and repeatable, following the evaluation to be conducted by the Technical Evaluation Group (INF GR/PS/106) [19/](#).

The TRL legform is able to estimate human knee injury risk and has been shown to be a durable and repeatable test tool, provided that handling procedures for the legform are carefully followed [20/](#).

2. Injury Criteria

Knee injuries, which are one of [the](#) typical leg injuries in car-to-pedestrian collisions, most frequently involve the elongation or rupture of knee ligaments, and/or crush of knee articulation surfaces (tibia plateau and/or femur condyle). Lower leg injuries are not typically fatal, but leg injuries generally involve longer periods of recuperation. Knee injuries can be permanently debilitating. The most common mechanism causing pedestrian knee injury is a lateral bending between the thigh and the leg, which can be associated with shearing motion (horizontal displacement between the tibia top and the femur lower extremity in the direction of impact).

The 2001 Report of the IHRA PS Working Group and the September 2002 Report of EEVC WG 17 [21/](#) discuss several experimental research programs that were conducted in Europe, Japan and the United States of America using PMHS components during the last decade. There were also numerical simulations conducted to understand better what happens inside the knee joint during the loading process.

These studies suggest a bending limit in the range of 15 to 21° for knee protection. The informal group determined that a value close to the upper limit (21°) of this range should be considered, and not the average. The absence of muscle tone in the PMHS tests reduced the knee stiffness of

[19/](#) The size and mass of both the present rigid lower legform and the Flex-PLI were determined to be equivalent to those of a 50th percentile adult male (INF GR/PS/79). The results of computer simulation analyses and experimental data indicate that the mass of the upper body need not be taken into consideration for those impacts where the bumper strikes the legs below knee level (INF GR/PS/105).

[20/](#) "Use of the TRL Legform to Assess Lower Leg Injury Risk," Stammen and Mallory, NHTSA VRTC, February 2006. INF GR/PS/XX

[21/](#) EEVC Working Group 17 Report: "Improved Test Methods to Evaluate Pedestrian Protection Afforded by Passenger Cars (December 1998 with September 2002 updates)," available at www.eevc.org

the subjects, and the high rigidity of the impactor bones transferred to the knee joint a part of the impact energy normally absorbed by the deformation of human long bones. For these reasons, a bending limit of 19° was selected for this gtr.

With regard to knee shearing limits, the informal group selected a limit of 6 mm, based on the analysis of PMHS by EEVC WG17 (id.) and WG10 that showed that a 6 mm shear displacement corresponds to a 4 kN shear force. The 4 kN shear force in the TRL device approximates the 3 kN average peak shearing force acting at the knee joint level that was found associated in the PMHS tests with diaphysis/metaphysis failure.

With regard to limiting the maximum acceleration on the tibia, results of a series of pedestrian PMHS tests performed with modern cars suggests that the maximum tibia acceleration for the PMHS sustaining a tibia fracture was 170 g to 270 g, with the average value of 222 g. A value of 200 g would correspond to a 50 percent injury risk. To protect a higher proportion of the population at risk, the informal group recommends a maximum lateral tibia acceleration limit of 170 g.

In summary, it was concluded that the acceptance levels for the lower legform test should be set at the following limits:

- Maximum lateral knee bending angle $\leq 19.0^\circ$;
- Maximum lateral knee shearing displacement ≤ 6.0 mm;
- Maximum lateral tibia acceleration ≤ 170 g.

These values are identical to those under consideration by the EC in its review of the Phase 2 requirements of the European directive.

3. Relaxation of Acceleration Limit

In order for the vehicle to provide adequate occupant protection in frontal crashes, portions of the vehicle bumper structure will have to be stiff enough to enable the vehicle to absorb a sufficient amount of the impact energy. In addition, the bumper structure contains towing hooks and other devices. Because of these factors, certain portions of the bumper will not be able to meet the maximum lateral tibia acceleration limit of 170 g across the full length of the bumper. For feasibility reasons, this gtr allows manufacturers to nominate bumper test widths up to 264 mm in total where the acceleration measured at the upper end of the tibia shall not exceed 250 g. The relaxation zone of 264 mm corresponds to an area that is twice the width of the legform.

(c) Upper Legform Test for High Bumpers

As discussed above, the informal group recognized that the lower leg impactor test would be inappropriate for vehicles whose bumpers strike the legs above knee level, but the group believed that vehicles with high bumpers should be subject to a test that would require the bumper to be more energy absorbing. For that reason, this gtr adopts the informal working group recommends an upper legform test for vehicles with a lower bumper height of more than 500 mm.

Data provided in INF GR/PS/175 Rev.2 indicate that, in order to meet the proposed criteria for the upper legform test, energy absorbing foam will have to be added to the bumper; such modifications are expected to reduce the risk of fractures which also constitutes an important injury risk.

1. Impactor

As the majority of victims of upper leg injuries are adults, the informal group generally agreed to ~~adopt~~recommend a subsystem test using a legform impactor that represents an upper adult leg. The impactor specifications in this proposed gtr are those used in the EU Directive 2003/102/EC for the upper legform impactor.

2. Injury Criteria

The gtr specifies that the instantaneous sum of the impact forces with respect to time shall not exceed 7.5 kN and that the bending moment on the test impactor shall not exceed 510 Nm. Biomechanical research of WG17 has found an upper leg tolerance in the range of 4 to 7 kN peak force, and 300 to 600 Nm bending moment. These values are based on PMHS test results, for a three-point bending in the middle of the femur. The absence of muscle tone in the PMHS tests and the difference in the impact point between the PMHS tests and the car impact would support a higher tolerance, especially for the peak force value. Accordingly, the informal group decided to ~~adopt~~recommend a 7.5 kN peak force limit, and a limit on bending moment of 510 Nm. These limits are the same as those under consideration by the EC for Phase 2 of the European directive.

3. Limits of the Upper Legform Test

Some delegates to the informal group were concerned that, although a test that encourages high bumpers to be more energy absorbing has merit, the benefits resulting from the existing upper legform test for high bumpers should be more sufficiently quantified and the suitability of the existing upper legform as a test device should be further examined. Interest was also expressed in developing a test device that could be used to test high bumpers to assess their potential for knee, thigh, hip, and pelvis injuries. ~~HRA is pursuing work~~Research is continuing in this area.

VIII. OTHER ISSUES

1. Systems or components that change position

Any vehicle system or component which could change shape or position, such as pop-up headlights or headlamp cleaners, other than active devices to protect pedestrians, were considered by the informal group to possibly create additional injury risks for pedestrians. It therefore was discussed whether such systems need to meet the requirements in their "normal position of use" or in any other possible position. During the discussion it became clear that currently, due to the fact of the latest developments in lighting technology, no vehicles with pop-up headlights exist on the market. Other systems such as headlamp cleaners move back to their stowed position under a small preload. Finally, the informal group therefore decided to ~~require~~recommend such active systems to be set to their stowed position when determining the

test areas. When performing the tests, the vehicle shall comply to the requirements with the components in each fixed shape or position (e.g. stowed and popped-up).

2. Active devices to protect pedestrians

The issue of active devices to protect pedestrians, such as deployable bonnets, was also discussed in detail. The group fully agreed that such devices must not create a higher risk of injuries for the pedestrians. A document entitled, "Certification Standard for Type Approval Testing of Active Deployable Systems of the Bonnet/Windscreen Area," proposed by Industry (INF GR/PS/141) was found to be acceptable as a guideline for certification of deployable devices, but the deployable devices clearly also need to satisfy all other requirements of this gtr. Contracting Parties who wish to implement national test procedures for these deployable devices may use the certification standard as its basis.

3. Impact on Existing Standards

During the discussions of the informal group, it was generally recognized that any proposed legislative requirements on pedestrian protection should be assessed against other vehicle parameters.

It was pointed out that both existing and future vehicle requirements should be taken into account, internationally as well as nationally, to ensure that potential conflicts are reduced as much as possible. The group also stressed that, in addition to legislative requirements, other vehicle parameters also need verification, in terms of customer satisfaction, repairability, insurance classification, comfort, handling, etc. A list of all necessary parameters was drafted for evaluation (INF GR/PS/35). Impacts of these standards and requirements were taken into account amongst others in the feasibility studies detailed in working papers INF GR/PS/91 and 101.

IX. REGULATORY IMPACT AND ECONOMIC EFFECTIVENESS

This global technical regulation is expected to reduce the number of pedestrian fatalities and injuries resulting from head impacts against the bonnet and leg impacts with the bumper. It will also maximize economic effectiveness of pedestrian protection regulations globally.

(a) Benefits

The informal working group recognizes that there are many variables affecting the potential benefits of this gtr, such as region-to-region differences in vehicle fleet composition, in driver behaviour, in the degree to which existing vehicles now meet the pedestrian protection requirements of this gtr or are otherwise equipped with safety features beneficial to pedestrians, and in the prevalence of pedestrian-friendly infrastructure. The group also recognizes that in estimating the potential benefits of this gtr, jurisdictions differed to a degree in their methodology and assumptions so that a direct comparison of benefits between regions was not possible. However, various delegates have made very preliminary estimates of benefits based on limited data currently available to the informal working group.

1. Head Protection

It is estimated that this gtr will prevent 1 to 5 percent of all pedestrian fatalities, depending on the region. Based on preliminary data, it is estimated that the head protection requirements would result in the following reduction in fatalities annually: in the European Union, about 361 pedestrians would be saved; in Korea, 175 lives saved; in Japan, 111 lives saved; and in the United States of America, between 20 to 60 lives saved. It is also expected that the head protection requirements would be beneficial for pedal-cyclists, which would add to these estimated lives saved.

2. Leg Protection

The group did not have assessments of the potential leg/knee injury benefits from each of the regions. At the end of the activities of the informal group, the United States of America made a preliminary assessment based upon NHTSA's Pedestrian Crash Data Study (PCDS is a database of 550 pedestrian crashes that occurred between 1994 and 1998), and for the approximately 70,000 annual pedestrian injuries in the United States.

Target population

The 32 per cent target population from INF GR/PS/169 includes both passenger cars and LTVs. The gtr exempts a rather large percentage of LTVs from having to test with a lower legform, therefore the target population should only include passenger cars and LTVs that have bumper heights below the defined ~~cutoff. From the cut off.~~

~~preliminary NHTSA studies on leg injuries in the United States of America, 42 per cent of AIS 2-6 injuries are lower extremity injuries and 36 per cent of AIS 3-6 injuries are lower extremity injuries. However, these do not represent the maximum AIS injury sustained, since other life threatening or fatal injuries could have occurred, in which case prevention of the lower leg injury would provide no overall benefit. From the PCDS cases, 56 per cent had MAIS 2-6 injuries and 36 per cent were MAIS 3-6. Thus, with 68,000 injured pedestrians, and using the above percentages of lower leg AIS and MAIS, the target population estimates for the United States of America are:~~

~~Of the MAIS 2-6, 42 per cent of them have a lower extremity leg injury as their worst injury:
 $68,000 \times 0.56 \times 0.42 = 15,994$ leg injuries (AIS 2-6)~~

~~Of the MAIS 3-6, 36 per cent of them~~Based on cases in the PCDS database, 56 per cent of pedestrians sustain injuries at the MAIS 2-6 severity level, and 42 per cent of those pedestrians have a lower extremity injury as their worst injury:

most severe, or tied for most severe injury. Therefore, based on the current US injury rate of 68,000 pedestrians, the annual numbers of $68,000 \times 0.36 \times 0.36 = 8,813$ leg injuries (AIS 3-6) pedestrians with a lower extremity injury as their most severe injury are:

Number of pedestrians with AIS 2+ lower extremity injuries as most serious injury:

= (number of annual injured pedestrians) x (percentage at MAIS 2-6 level) x (percentage where LE most serious)

□ $68,000 \times 0.56 \times 0.42$

= 15,994 pedestrians with AIS 2+ lower extremity injury as a highest severity injury.

~~These are the target populations~~This number is the target population for all lower extremity (LE) injuries, not the ones specific to the gtr. Thus, the group had to account for the percentage of ~~vehicles and~~ specific injury types and vehicles covered by the gtr. Of the AIS 2-6 lower extremity injuries in PCDS, 56 per cent are to the knee and lower leg are considered target injuries for the gtr. According to the PCDS data, 100 per cent of passenger cars and 87 per cent of light trucks and vans have a lower bumper height of at or below 500 mm and could potentially be tested with the lower legform test. PCDS data show that passenger cars account for 84 per cent and light trucks and vans for 16 percent of the total lower leg and knee injuries at the AIS 2-6 severity level. In passenger car ~~impacts, 81 per~~impacts to pedestrians, 81 per cent of knee and lower leg injuries were attributed to bumper ~~contact.~~ Further excluding the injuries not accounted for by the injury assessment reference values of the gtr, yields lower leg and knee injuries only. ~~Of the AIS 2-6 lower extremity injuries, 56 per cent are knee and lower leg. Of the AIS 3-6 leg injuries, 50 per cent are knee and lower leg. From PCDS, passenger cars account for 84 percent and LTVs for 16 per cent of the total lower leg and knee injuries for both AIS 2-6 and AIS 3-6. Accordingly, the following is the target population for the lower leg injuries addressed by the gtr:~~

~~Target population (AIS 2-6): 15,994 x 0.56 x (0.84 x 1.00 x 0.81 + 0.16 x 0.87 x 0.72) = 6,992 leg injuries.~~

~~Target population (AIS 3-6): 8,813 x 0.50 x (0.84 x 1.00 x 0.81 + 0.16 x 0.87 x 0.72) = 3,440 leg injuries.~~

Lower leg benefits

~~The United States of America calculated benefits based on experimental testing of 5 vehicles 22/ in collaboration with Transport Canada. An estimate based on the geometry of the 5 bumpers tested showed that the total testable area on the bumpers was approximately 80 per cent of their width. The 264 mm relaxation zone of the bumper that is required to meet the higher 250 g requirement is approximately 15 per cent of the total bumper width. The remaining primary test area of the bumper covered by the lower 170 g requirement is approximately 65 per cent. Results from the testing estimated 42 per cent improvement to the overall risk injury in the primary test area and 14 per cent improvement in the relaxation zone. Accordingly, the following are the lower leg injuries prevented by the gtr:~~

~~AIS 2-6 injuries prevented = 6,992 x (0.42 x 0.65 + 0.14 x 0.15) = 2,056~~

~~AIS 3-6 injuries prevented = 3,440 x (0.42 x 0.65 + 0.14 x 0.15) = 1,012~~

~~As stated above the testable percentage of the bumper was estimated to be 80 per cent, about 10 per cent of which is outboard of the gtr-defined bumper "corner". This area is generally oriented laterally and would therefore not be expected to deliver a direct blow to a pedestrian leg. In fact, it is expected that the vast majority of lower extremity impacts would occur between the bumper corners, suggesting that closer to 90 per cent of all bumper-related injuries occur with the testable area, rather than the 80 per cent estimated in these calculations. If the higher testable~~

~~22/—Mallory A, Stammen JA, Legault F. "Component Leg Testing of Vehicle Front Structures," Paper No. 05-0194, Nineteenth International Technical Conference on the Enhanced Safety of Vehicles, June 2005.~~

~~area number were used, the injuries prevented would be expected to increase by approximately 10 per cent.~~

~~As a result of these conservatively low estimates of target population, improvement as a result of gtr requirements, and testable area, these estimates of injuries prevented should be considered as the minimum likely benefit from the gtr requirements.~~

~~(b) — Costs~~

~~The added cost per vehicle to meet requirements of this gtr is estimated to be approximately 45 Euros (63 U.S. Dollars). For minivans this is estimated to be around 32.50 Euros (45.50 US Dollars). The EU feasibility study (INF GR/PS/89) also addressed small sports cars with the conclusion that for these vehicles the cost could be substantially higher i.e. up to 410 Euros (574 US Dollars) due to the perceived need for popup bonnets. Industry representatives to the informal working group indicated that the majority of these costs, but at least up to two-thirds, will result from the head protection requirements, and only the rest will result from the leg protection requirements.~~

APPENDIX—REFERENCE DOCUMENTS USED BY THE WORKING GROUP

A list of working papers used by the informal working group is listed and available on the UNECE WP.29 website (<http://www.unece.org/trans/main/welewp29.htm>):

Number of working paper	Title of informal document
INF-GR/PS/1 and Rev 1	Agenda 1st meeting
INF-GR/PS/2	Terms of reference
INF-GR/PS/3	IHRA accident study presentation
INF-GR/PS/4 and Rev 1	JMLIT proposed legislation
INF-GR/PS/5	IHRA feasibility study
INF-GR/PS/6	J-information on possible scope
INF-GR/PS/7	Attendance list 1st meeting
INF-GR/PS/8 and Rev 1	Draft Meeting Minutes 1st meeting
INF-GR/PS/9 and Rev 1	Report to GRSP 32-inf doc
INF-GR/PS/10	Draft action plan
INF-GR/PS/11	Agenda 2nd meeting
INF-GR/PS/12	GIDAS accident data
INF-GR/PS/13	GIDAS accident data graphs
INF-GR/PS/14	Italian accident data
INF-GR/PS/15	UN accident data
INF-GR/PS/16	Spanish accident data
INF-GR/PS/17	ACEA accident data
INF-GR/PS/18	Draft Meeting Minutes 2nd meeting
INF-GR/PS/19	Agenda 3rd meeting
INF-GR/PS/20	Canadian accident data
INF-GR/PS/21	Netherlands accident data
INF-GR/PS/22	Scope overview
INF-GR/PS/23	Draft content table preliminary report
INF-GR/PS/24	Attendance list 3rd meeting
INF-GR/PS/25	GIDAS presentation
INF-GR/PS/26	Leg injuries ITARDA
INF-GR/PS/27 and Rev 1	Draft Meeting Minutes 3rd meeting
INF-GR/PS/28	Technical feasibility general
INF-GR/PS/29	Infrastructure effectiveness
INF-GR/PS/30	Pelvis / Femur fracture
INF-GR/PS/31	IHRA/PS-WG Pedestrian accident data
INF-GR/PS/32	ESV summary paper on IHRA/PS-WG report
INF-GR/PS/33	Introduction of the regulation of pedestrian head protection in Japan; Nishimoto, Toshiyuki

Number of working paper	Title of informal document
INF-GR/PS/34	Proposal for a directive of the European Parliament and the Council relating to the protection of pedestrians and other vulnerable road users in the event of a collision with a motor vehicle and amending Directive 70/156/EEC; Commission of the European Communities, Brussels, February 2003
INF-GR/PS/35	List of conflicts with existing legislation / requirements
INF-GR/PS/36	Draft preliminary report
INF-GR/PS/37	Agenda 4th meeting
INF-GR/PS/38	Technical prescriptions concerning test provisions for pedestrian safety
INF-GR/PS/39 and Rev 1	Vehicle safety standards report 1
INF-GR/PS/40	US Cumulative 2002 Fleet GVMR
INF-GR/PS/41	Swedish accident data
INF-GR/PS/42	TRANS/WP.29/GRSG/2003/10 proposal for common definitions
INF-GR/PS/43	Category 1-1 GVM
INF-GR/PS/44	Light duty truck
INF-GR/PS/45	EURO-NCAP results and what they mean in relation to EU Phase 1
INF-GR/PS/46	JAMA / JARI child and adult head impactors
INF-GR/PS/47 and Rev 1	Preliminary report to GRSP 33
INF-GR/PS/48 and Rev 1	Draft meeting minutes 4th meeting
INF-GR/PS/49	IHRA child head test method
INF-GR/PS/50	IHRA adult head test method
INF-GR/PS/51	Attendance list 4th meeting
INF-GR/PS/52	Provisional agenda for the 5th meeting
INF-GR/PS/53	Draft gtr format
INF-GR/PS/54	gtr proposal to WP29
INF-GR/PS/55	Draft gtr
INF-GR/PS/56 and Rev 1	Comparison table
INF-GR/PS/57	Proposed schedule of the group
INF-GR/PS/58	Presentation on veh shape, bound line, ...
INF-GR/PS/59	A-pillar IHRA OICA presentation
INF-GR/PS/60	ISO/TC22/SC10/WG2 N613
INF-GR/PS/61	IHRA PS 237
INF-GR/PS/62	Action plan from 5 meeting
INF-GR/PS/63	Attendance list 5th meeting
INF-GR/PS/64 and Rev 1	Draft meeting minutes 5th meeting
INF-GR/PS/65 and Rev 1	Provisional agenda for the 6th meeting
INF-GR/PS/66	AUS-NCAP pedestrian data
INF-GR/PS/67	Test method – active hood / bonnet systems
INF-GR/PS/68	Target population head injuries – US
INF-GR/PS/69	Working paper draft gtr

Number of working paper and Rev 1	Title of informal document
INF-GR/PS/70	Korean information
INF-GR/PS/71	Head test area windscreen + A-pillar
INF-GR/PS/72	Head test data on windscreen
INF-GR/PS/73	Head impact angle / speed re-assessment based on vehicle geometry
INF-GR/PS/74	IHRA/PS/270 headform impactor specification
INF-GR/PS/75	Powerpoint explanation of PS/67
INF-GR/PS/76	IHRA legform discussions
INF-GR/PS/77	Corridors proposed by UVA (lower legform)
INF-GR/PS/78	Bio-rating method: Maltese
INF-GR/PS/79	IHRA antropometric proposal
INF-GR/PS/80	IHRA/PS/278
INF-GR/PS/81	Schedule for legform impactor for gtr
INF-GR/PS/82	Injury threshold for ped legform test
INF-GR/PS/83	Decided items and action items of the 6th meeting
INF-GR/PS/84	Draft meeting minutes of the 6th meeting
INF-GR/PS/85	Attendance list of the 6th meeting
INF-GR/PS/86 and Rev 1/2	Draft gtr EU working document
INF-GR/PS/87	IHRA PS 273 Development of FlexPLI2003
INF-GR/PS/88	Second interim report to GRSP 35
INF-GR/PS/89	EU Feasibility Study Phase 2
INF-GR/PS/90	Provisional agenda for the 7th meeting
INF-GR/PS/91	ACEA feasibility study Phase 2
INF-GR/PS/92	ACEA equal effectiveness study Phase 2
INF-GR/PS/93	Design of head impactor
INF-GR/PS/94	Front windshield
INF-GR/PS/95	JPN comment on PS 86 Rev 2 + English text of Japanese technical standard
INF-GR/PS/96	Problem of undamped accelerometer
INF-GR/PS/97	Durability and repeatability of headform skin
INF-GR/PS/98	IHRA PS 310 decision for legform test
INF-GR/PS/99	Skin aging of head impactor
INF-GR/PS/100	OICA proposed amendments to PS/95
INF-GR/PS/101	JAMA feasibility study Phase 2
INF-GR/PS/102	OICA windscreen testing according to EURO-NCAP protocol
INF-GR/PS/103	CLEPA windscreen testing on one car model
INF-GR/PS/104	Draft CLEPA / OICA document on active bonnet testing
INF-GR/PS/105	Lower leg research for developing corridors
INF-GR/PS/106	J-MLIT proposal for FlexPLI answering item 9 of PS/83
INF-GR/PS/107	NHTSA proposal for guidelines of preamble
INF-GR/PS/108	JAMA information on high bumper definition
INF-GR/PS/109	Chairman proposal for FlexPLI and rigid impactor use in gtr
INF-GR/PS/110	OICA proposal for side and rear windscreen reference line
INF-GR/PS/111 and Rev 1	Guideline for preamble

Number of working paper	Title of informal document
INF-GR/PS/112	Action plan
INF-GR/PS/113	Revision of draft gtr
INF-GR/PS/114	Attendance list
INF-GR/PS/115 and Rev 1	Draft meeting minutes of the 7th meeting
INF-GR/PS/116	Cleaned up version of draft gtr
INF-GR/PS/117	Preamble and draft gtr off doc for GRSP-37
INF-GR/PS/118 and Rev 1	Provisional agenda for the 8th meeting
INF-GR/PS/119	ISO Activities for Pedestrian Safety
INF-GR/PS/120	EC final feasibility study
INF-GR/PS/121	GRSP/2005/3 as amended during GRSP/37
INF-GR/PS/122	GRSP-37-18
INF-GR/PS/123	GRSP-37-15
INF-GR/PS/124	GRSP-37-16
INF-GR/PS/125	Short report on comments received during GRSP-37
INF-GR/PS/126	July meeting task list
INF-GR/PS/127	Presentation on EU Phase 2
INF-GR/PS/128	The need for harmonized legislation on pedestrian protection
INF-GR/PS/129	Comparison between the J standard and the EU Phase 2 proposal for head testing
INF-GR/PS/130	List of references for EU / EEVC on head impact angles
INF-GR/PS/131	Analysis of pedestrian accident situation and portion addressed by this gtr
INF-GR/PS/132	gtr testing and what it means for the US situation
INF-GR/PS/133 and Rev 1	Proposal to solve the undamped accelerometer problem
INF-GR/PS/134	Concerns on §7.4 with testing on the centre of the windscreen
INF-GR/PS/135	OICA proposal for §3.33
INF-GR/PS/136	OICA proposal for a mass for the upper leg impactor
INF-GR/PS/137	OICA proposal on definition of high bumper vehicles
INF-GR/PS/138	Economic effectiveness study from Korea
INF-GR/PS/139	Action list of 8th meeting
INF-GR/PS/140	IHRA Injury breakdown background document for PS/131
INF-GR/PS/141	Update of PS67 on certification standard for deployable systems
INF-GR/PS/142	Relative humidity of Korea
INF-GR/PS/143 and Rev 1	Draft gtr based on INF-GR / PS / 121 as amended during the 8th meeting
INF-GR/PS/144 and Rev 1	Draft meeting minutes of the 8th meeting
INF-GR/PS/145	Attendance list 8th meeting
INF-GR/PS/146	Flex-TEG Activities updating PS 124
INF-GR/PS/147	Actions 1 3 4 6 9 of 8th meeting
INF-GR/PS/148	Action 9 of 8th meeting doc FTSS_4[1].5kg_headform
INF-GR/PS/149	Adult headform moment of inertia
INF-GR/PS/150	Development of a head impact test, Glaeser

Number of working paper	Title of informal document
INF GR/PS/151	gtr preamble for accelerometer
INF GR/PS/152	Provisional agenda for the 9th meeting
INF GR/PS/153	Explanation of amendments from PS143 to PS143 Rev1
INF GR/PS/154 and Rev 1	Handling guide for the TRL leg
INF GR/PS/155	LWRL definition
INF GR/PS/156	Impact angles for headform to windscreen tests
INF GR/PS/157	HIC limits for headform to windscreen tests
INF GR/PS/158	Headform to bonnet tests
INF GR/PS/159	Definition high bumper vehicles
INF GR/PS/160	Revised preamble replacing the preamble in PS/143 Rev 1
INF GR/PS/161 and Rev 1/2	EU proposed amendments to 143 Rev 1
INF GR/PS/162	Explanation of EU proposals to amend R143 Rev 1
INF GR/PS/163	Windscreen impact testing
INF GR/PS/164	Windscreen fracture modes
INF GR/PS/165	Leg feasibility testing
INF GR/PS/166	Relaxation zone and GVWR application
INF GR/PS/167	EU field data on crossbeam height
INF GR/PS/168	HIC15 vs HIC36 headaccel analysis
INF GR/PS/169	Revising PS 131 -- Analysis of Pedestrian Accident and gtr Application
INF GR/PS/170	Target population for this gtr
INF GR/PS/171	Draft meeting minutes of the 9th meeting
INF GR/PS/172	Attendance list 9th meeting
INF GR/PS/173	Provisional agenda for the 10th meeting
INF GR/PS/174 and Rev 1	Lower leg tests -- EuroNCAP data -- OICA presentation for Jan 06 meeting
INF GR/PS/175 and Rev 1/2	Bumper Reference Lines -- OICA presentation for Jan 06 meeting
INF GR/PS/176 and Rev 1/2	Headform test results -- OICA presentation for Jan 06 meeting
INF GR/PS/177	IHRA PS Proposal for the Moment of Inertia of gtr Adult Child Headform Impactors
INF GR/PS/178	Expected life saving effect gtr Head Japan
INF GR/PS/179	Ongoing Researches on Pedestrian Leg Injuries Assessment
INF GR/PS/180	OICA position on the change of the definition of the ble reference line
INF GR/PS/181	Comparison lower leg injuries for different AIS levels
INF GR/PS/182	Foam memory for changing humidity
INF GR/PS/183	OICA position on bonnet leading edge 165 mm exemption zone
INF GR/PS/184	Final draft gtr (without preamble)
INF GR/PS/185	Mr Saul letter dated on 3/1/2006
INF GR/PS/186	NHTSA revision of preamble PS/160
INF GR/PS/187	EEVC WG17 report
INF GR/PS/188	Draft meeting minutes of the 10th meeting
INF GR/PS/189	Attendance list 10th meeting

~~B. TEXT OF THE REGULATION~~

~~1. PURPOSE AND SCOPE~~

~~1.1. The purpose of this global technical regulation is to bring about an improvement in the construction of certain parts of the front of vehicles which have been identified as causing injury when in collision with a pedestrian or other vulnerable road user.~~

~~The vehicles to be tested under the regulation are representative of the majority of vehicles in circulation in the urban environment, where there is a greater potential for collision with pedestrians and other vulnerable road users, and include passenger cars, vans and light trucks.~~

~~2. APPLICATION~~

~~This global technical regulation (gtr) shall apply to the frontal surfaces of power driven vehicles of category 1-1 [with a gross vehicle mass exceeding 0.5 tonnes but not exceeding 2.5 tonnes], and of category 2 [with a gross vehicle mass exceeding 0.5 tonnes but not exceeding 2.5 tonnes], which forward of the A-pillars have the same general structure and shape as a pre-existing category 1-1 vehicle. All definitions of Special Resolution No. 1 (S.R.1) shall apply as necessary.~~

~~3. DEFINITIONS~~

~~When performing measurements as described in this Part, the vehicle should be positioned in its normal ride attitude.~~

~~If the vehicle is fitted with a badge, mascot or other structure, which would bend back or retract under an applied load of maximum 100 N, then this load shall be applied before and/or while these measurements are taken.~~

~~Any vehicle component which could change shape or position, other than suspension components or active devices to protect pedestrians, shall be set to their stowed position.~~

~~For the purposes of this regulation:~~

~~3.1. "Adult headform test area" is an area on the outer surfaces of the front structure. The area is bounded, in the front, by a wrap around distance of 1,700 mm and, at the rear, by the rear reference line for adult headform and, at each side, by the side reference line.~~

~~3.2. "A-pillar" means the foremost and outermost roof support extending from the chassis to the roof of the vehicle.~~

~~3.3. "Bonnet leading edge" means the edge of the front upper outer structure of the vehicle, including the bonnet and wings, the upper and side members of the headlight surrounds and any other attachments. The reference line identifying the position of the bonnet leading edge is defined by its height above the ground reference plane and by the horizontal distance separating it from the bumper (bumper lead).~~

~~3.4. "Bonnet leading edge height" means, at any point on the bonnet leading edge, the vertical distance between the ground reference plane and the bonnet leading edge reference line at that point.~~

~~3.5. "Bonnet leading edge reference line" means the geometric trace of the points of contact between a straight edge 1,000 mm long and the front surface of the bonnet, when the straight edge, held parallel to the vertical longitudinal plane of the car and inclined rearwards by 50° from the vertical and with the lower end 600 mm above the ground, is traversed across and in contact with the bonnet leading edge (see Figure 1).~~

~~— For vehicles having the bonnet top surface inclined at 50°, so that the straight edge makes a continuous contact or multiple contacts rather than a point contact, determine the reference line with the straight edge inclined rearwards at an angle of 40° from the vertical.~~

~~— For vehicles of such shape that the bottom end of the straight edge makes first contact with the vehicle then that contact is taken to be the bonnet leading edge reference line, at that lateral position.~~

~~— For vehicles of such shape that the top end of the straight edge makes first contact with the vehicle then the geometric trace of 1,000 mm wrap around distance, will be used as bonnet leading edge reference line at that lateral position.~~

~~— The top edge of the bumper shall also be regarded as the bonnet leading edge if it is contacted by the straight edge during this procedure.~~

~~3.6. "Bonnet rear reference line" means the geometric trace of the most rearward points of contact between a 165 mm diameter sphere and the front structure of the vehicle when the sphere is traversed across the front structure of the vehicle while maintaining contact with the windscreen (see Figure 2).~~

~~— Where the bonnet rear reference line and the side reference line do not intersect, the bonnet rear reference line should be extended and/or modified using a semi-circular template, of radius 100 mm. The template should be made of a thin flexible sheet material that easily bends to a single curvature in any direction. The template should, preferably, resist double or complex curvature where this could result in wrinkling. The recommended material is a foam backed thin plastic sheet to allow the template to "grip" the surface of the vehicle. The template should be marked up with four points "A" through "D", as shown in Figure 3, while the template is on a flat surface.~~

~~— The template should be placed on the vehicle with Corners "A" and "B" coincident with the side reference line. Ensuring these two corners remain coincident with the side reference line, the template should be slid progressively rearwards until the arc of the template makes first contact with the bonnet rear reference line. Throughout the process, the template should be curved to follow, as closely as possible, the outer contour of the vehicle's bonnet top, without wrinkling or folding of the template. If the contact between the template and bonnet rear reference line is tangential and the point of tangency lies~~

~~outside the arc scribed by points "C" and "D", then the bonnet rear reference line is extended and/or modified to follow the circumferential arc of the template to meet the bonnet side reference line, as shown in Figure 4.~~

~~— If the template cannot make simultaneous contact with the bonnet side reference line at points "A" and "B" and tangentially with the bonnet rear reference line, or the point at which the bonnet rear reference line and template touch lies within the arc scribed by points "C" and "D", then additional templates should be used where the radii are increased progressively in increments of 20 mm, until all the above criteria are met.~~

3.7. ~~"Bonnet top" is the area which is bounded by (a), (b) and (c) as follows:~~

- ~~— (a) — the bonnet leading edge reference line;~~
- ~~— (b) — the bonnet rear reference line;~~
- ~~— (c) — the side reference lines.~~

3.8. ~~"Bumper" means the front, lower, outer structure of a vehicle. It includes all structures that are intended to give protection to a vehicle when involved in a low speed frontal collision and also any attachments to this structure. The reference height and lateral limits of the bumper are identified by the corners and the bumper reference lines.~~

3.9. ~~"Bumper lead" means for any longitudinal section of a vehicle, the horizontal distance in the vehicle longitudinal plane between the upper bumper reference line and the bonnet leading edge reference line~~

3.10. ~~"Bumper test area" means the frontal surface of the bumper limited by two longitudinal vertical planes intersecting the corners of the bumper and moved 66 mm parallel and inboard of the corners of the bumpers.~~

3.11. ~~"Centre of the knee" of the lower legform impactor is defined as the point about which the knee effectively bends.~~

3.12. ~~"Child headform test area" is an area on the outer surfaces of the front structure. The area is bounded, in the front, by the front reference line for child headform, and, at the rear, by the WAD1700 line, and by the side reference lines.~~

3.13. ~~"Corner of bumper" means the vehicle's point of contact with a vertical plane which makes an angle of 60° with the vertical longitudinal plane of the car and is tangential to the outer surface of the bumper (see Figure 5).~~

3.14. ~~"Femur" of the lower legform impactor is defined as all components or parts of components (including flesh, skin covering, damper, instrumentation and brackets, pulleys, etc. attached to the impactor for the purpose of launching it) above the level of the centre of the knee.~~

3.15. ~~"Front reference line for child headform" means the geometric trace as described on the vehicle front structure using a WAD1000 line. In the case of vehicles where the wrap around distance to the bonnet leading edge reference line, is more than 1,000 mm at any~~

point, then the bonnet leading edge reference line will be used as the front reference line for child headform at that point.

- 3.16. ~~"Front structure" means all outer structures of the vehicle except the windscreen, the windscreen header, the A-pillars and structures rearward of these. It therefore includes, but is not limited to, the bumper, the bonnet, wings, scuttle, wiper spindles and lower windscreen frame.~~
- 3.17. ~~"Ground reference plane" means a horizontal plane, either real or imaginary, that passes through the lowest points of contact for all tyres of a vehicle while the vehicle is in its normal ride attitude. If the vehicle is resting on the ground, then the ground level and the ground reference plane are one and the same. If the vehicle is raised off the ground such as to allow extra clearance below the bumper, then the ground reference plane is above ground level.~~
- 3.18. ~~"Head Injury Criterion (HIC)" means the calculated result of accelerometer time histories using the following formula:~~

$$\text{HIC} = \left[\frac{1}{t_2 - t_1} \int_{t_1}^{t_2} a \, dt \right]^{2.5} (t_2 - t_1)$$

- ~~Where:~~
- ~~a is the resultant acceleration measured in units of gravity "g" (1 g = 9.81 m/s²);~~
 - ~~t₁ and t₂ are the two time instants (expressed in seconds) during the impact, defining an interval between the beginning and the end of the recording period for which the value of HIC is a maximum (t₂ - t₁ ≤ 15 ms)~~
- 3.19. ~~"Impact point" means the point on the vehicle where initial contact by the test impactor occurs. The proximity of this point to the target point is dependent upon both the angle of travel by the test impactor and the contour of the vehicle surface (see point B in Figure 6).~~
- 3.20. ~~"Lower bumper height" means the vertical distance between the ground reference plane and the lower bumper reference line, with the vehicle positioned in its normal ride attitude.~~
- 3.21. ~~"Lower bumper reference line" means the lower limit to significant points of pedestrian contact with the bumper. It is defined as the geometric trace of the lowermost points of contact between a straight edge 700 mm long and the bumper, when the straight edge, held parallel to the vertical longitudinal plane of the car and inclined forwards by 25° from the vertical, is traversed across the front of the car, while maintaining contact with the ground and with the surface of the bumper (see Figure 7).~~
- 3.22. ~~"Normal ride attitude" means the vehicle positioned on a flat horizontal surface with its mass in running order (as defined in Annex 3, paragraph 3 of Special Resolution No. 1), with the tyres inflated to manufacturer recommended pressures, the front wheels in the straight-ahead position and with a passenger mass (as defined in Annex 3, paragraph 6.2.~~

~~of Special Resolution No. 1) placed on the front passenger seat. The front seats are placed at the nominal mid-track position. The suspension shall be set in normal running condition as specified by the manufacturer for a speed of 40 km/h.~~

~~3.23. "Rear reference line for adult headform" means a geometric trace as described on the front structure of the vehicle using a WAD2100 line.~~

~~3.24. "Side reference line" means the geometric trace of the highest points of contact between a straight edge 700 mm long and the sides of the vehicle, when the straight edge, held parallel to the transverse vertical plane of the vehicle and inclined inwards by 45°, is traversed down, and maintains contact with the sides of the front structure (see Figure 8).~~

~~3.25. "Target point" means the intersection of the projection of the headform longitudinal axis with the front surface of the vehicle (see point A in Figure 6.).~~

~~3.26. "Tibia" of the lower legform impactor is defined as all components or parts of components (including flesh, skin covering, instrumentation and brackets, pulleys, etc. attached to the impactor for the purpose of launching it) below the level of the centre of the knee. Note that the tibia as defined includes allowances for the mass, etc., of the foot.~~

~~3.27. "Upper bumper reference line" means the upper limit to significant points of pedestrian contact with the bumper. For vehicles with an identifiable bumper structure it is defined as the geometric trace of the uppermost points of contact between a straight edge and the bumper, when the straight edge, held parallel to the vertical longitudinal plane of the car and inclined rearwards by 20° to the vertical, is traversed across the front of the car, while maintaining contact with the surface of the bumper (see Figure 9).~~

~~— For vehicles with no identifiable bumper structure it is defined as the geometric trace of the uppermost points of contact between a straight edge 700 mm long and the bumper area, when the straight edge, held parallel to the vertical longitudinal plane of the car and inclined rearwards by 20° from the vertical is traversed across the front of the car, while maintaining contact with the ground and with the surface of the bumper area (see Figure 9).~~

~~3.28. "Wrap Around Distance (WAD)" means the geometric trace described on the outer surface of the vehicle front structure by one end of a flexible tape, when it is held in a vertical longitudinal plane of the vehicle and traversed across the front structure. The tape is held taut throughout the operation with one end held at ground reference level, vertically below the front face of the bumper and the other end held in contact with the front structure (see Figure 10). The vehicle is positioned in the normal ride attitude.~~

~~— This procedure shall be followed, using alternative tapes of appropriate lengths, to describe wrap around distances of 1,000 mm (WAD1000), of 1,700 mm (WAD1700) and of 2,100 mm (WAD2100).~~

3.29. "Windscreen" means the frontal glazing of the vehicle situated between the A-pillars.

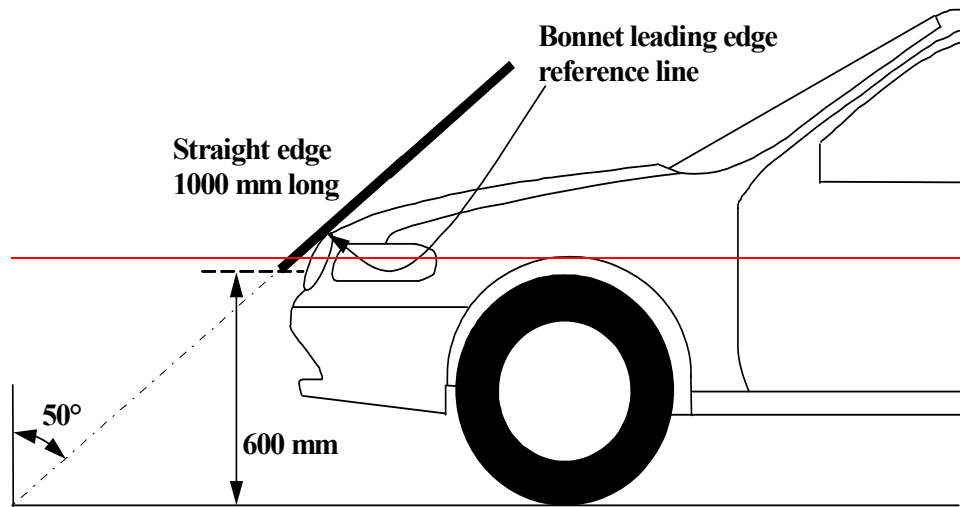

Figure 1: — Bonnet leading edge reference line. (see paragraph 3.5.)

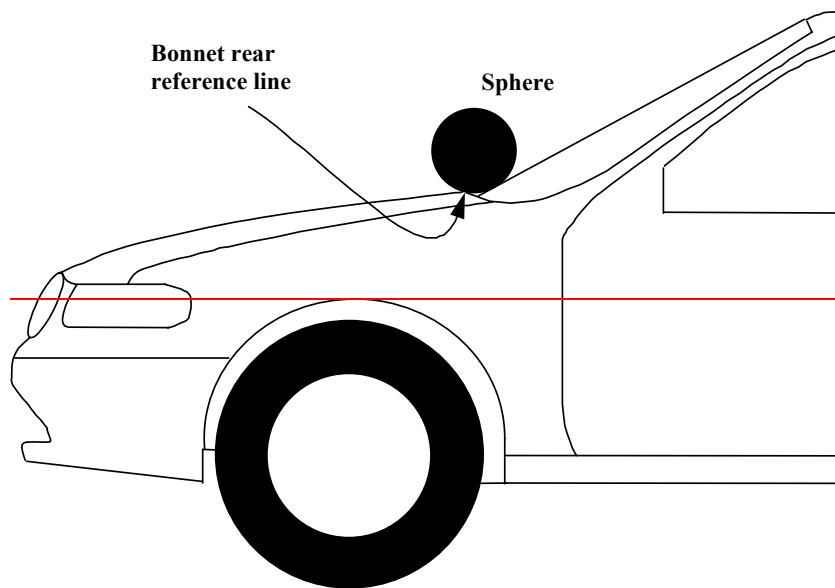

Figure 2: — Bonnet rear reference line. (see paragraph 3.6.)

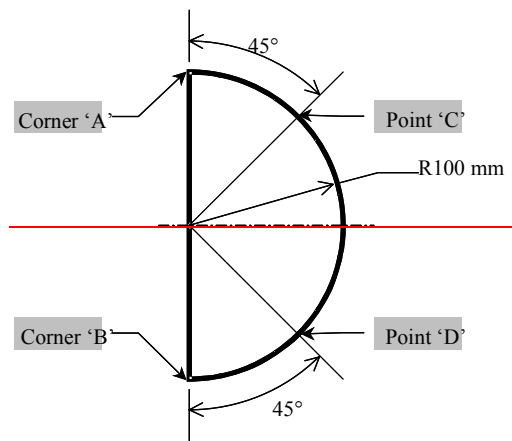

Figure 3: ~~Template. (see paragraph 3.6.)~~

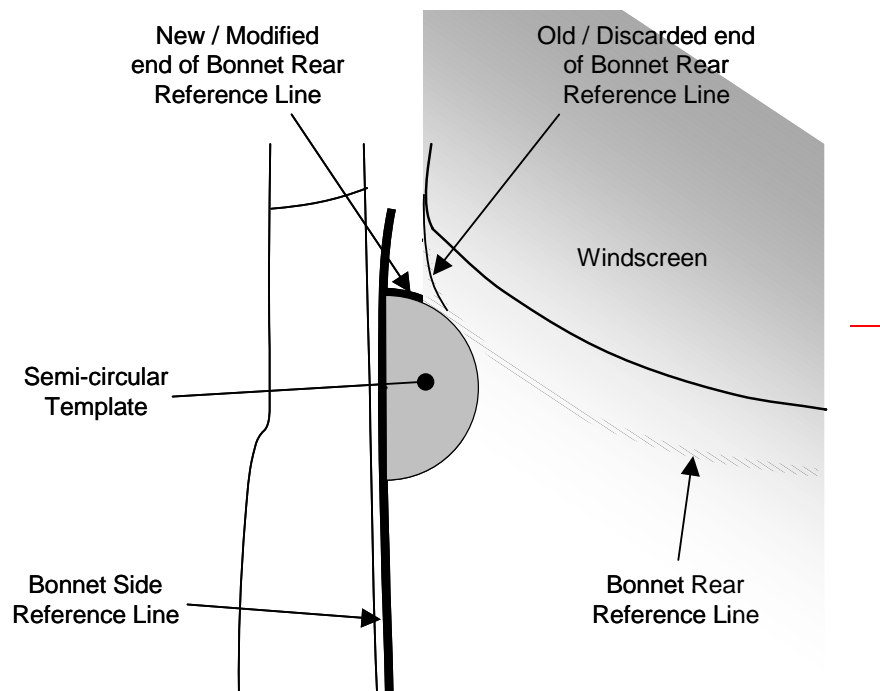

Figure 4: ~~Marking of intersection between bonnet rear and side reference lines (see paragraph 3.6.)~~

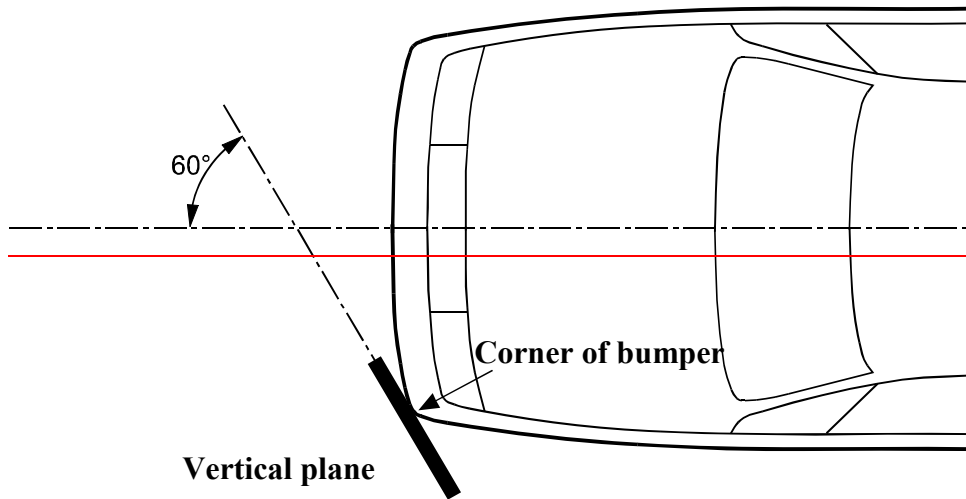

Figure 5: Corner of bumper (see paragraph 3.13.)

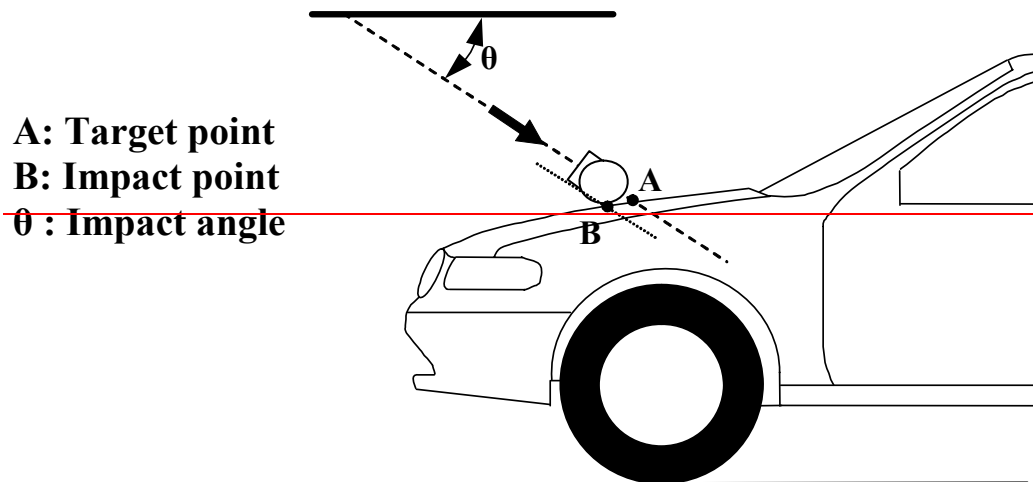

Figure 6: Impact and target point (see paragraphs 3.19. and 3.25.)

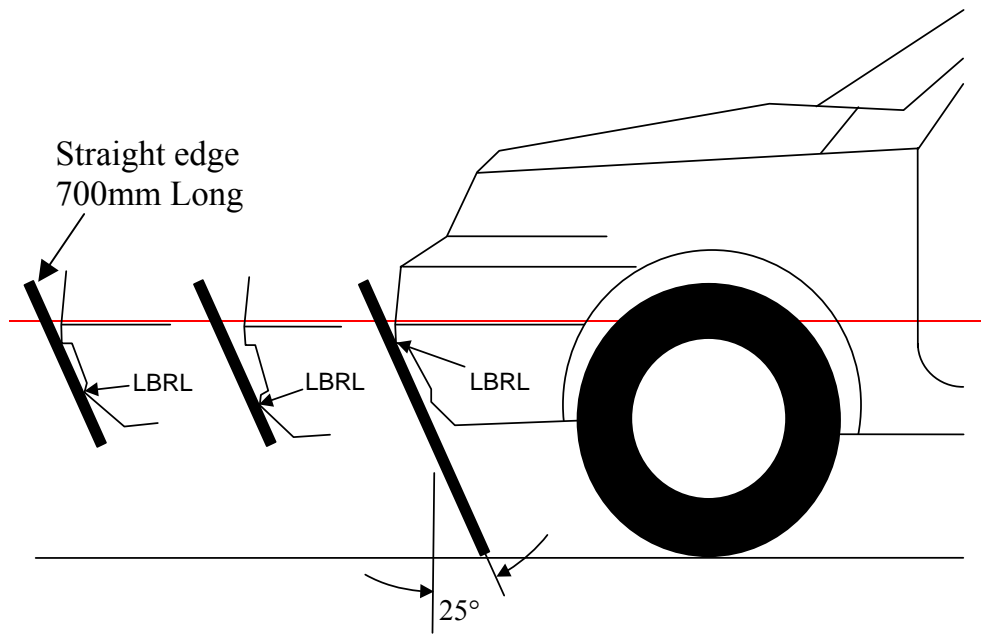

Figure 7: Lower bumper reference line, LBRL (see paragraph 3.21.)

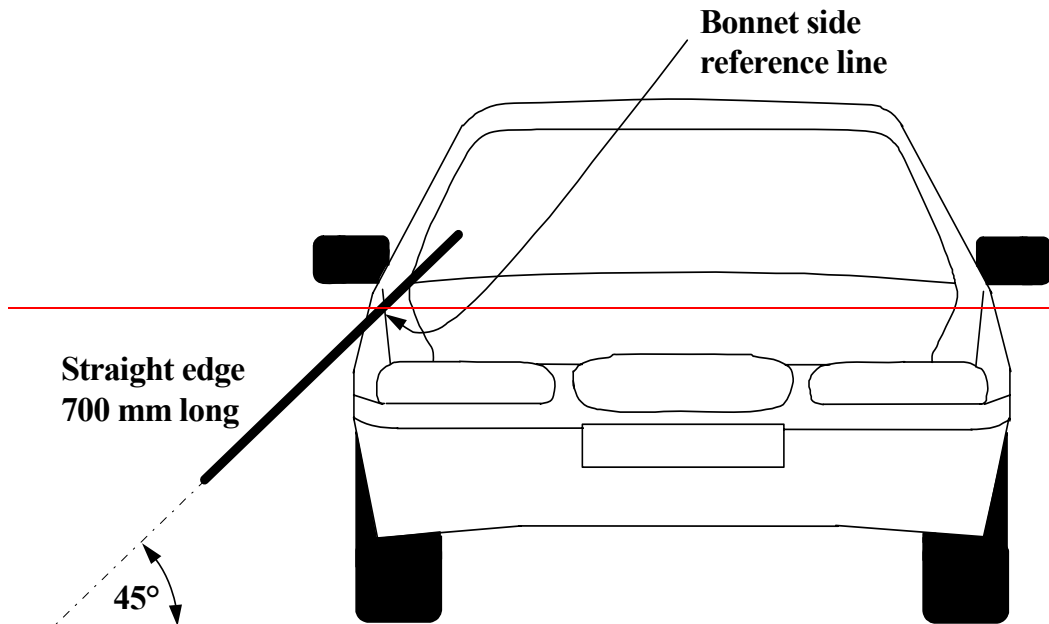

Figure 8: Side reference line (see paragraph 3.24.)

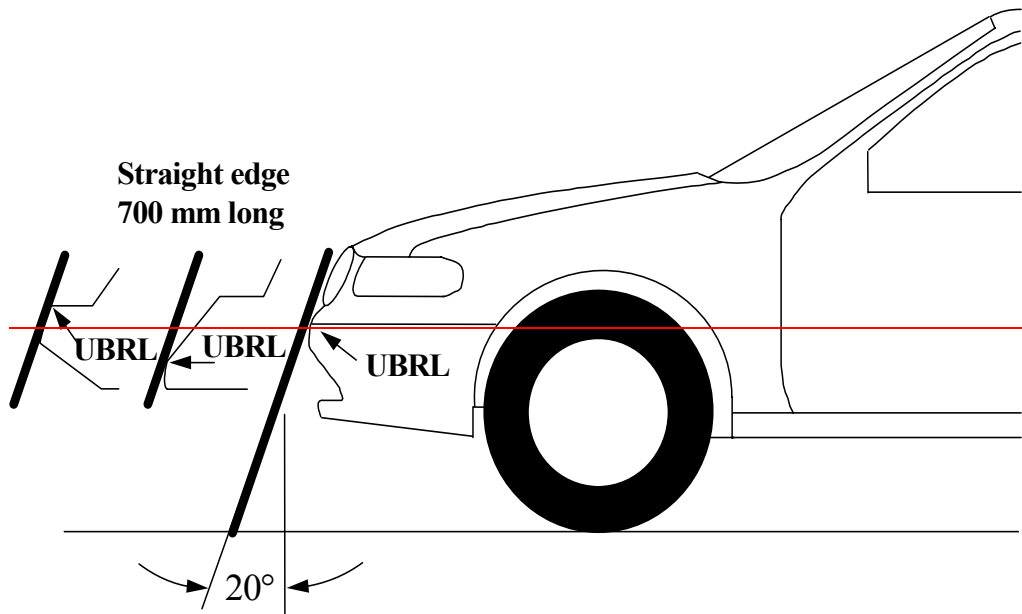

Figure 9: Upper bumper reference line, UBRL (see paragraph 3.27.)

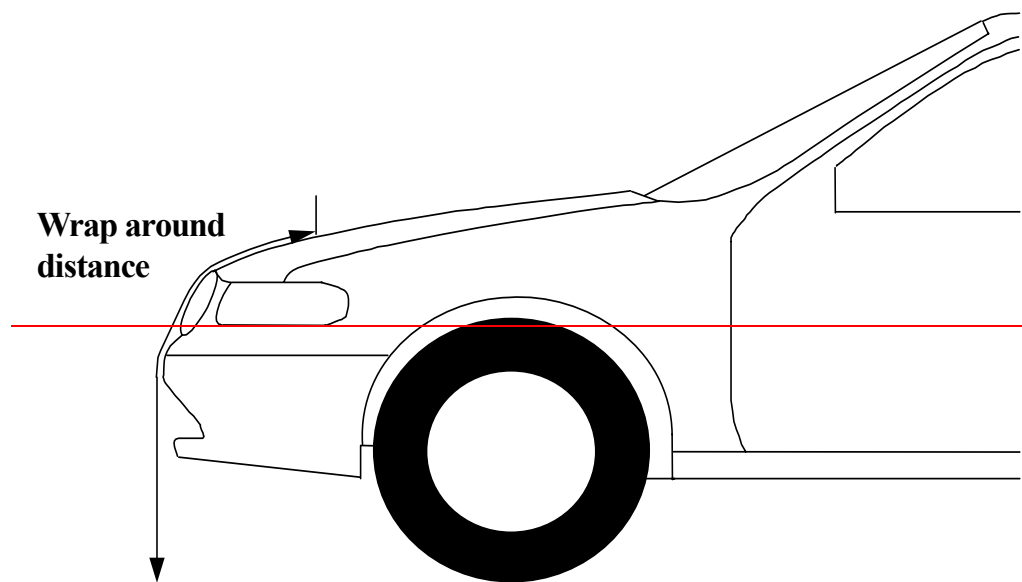

Figure 10: Wrap around distance measurement (see paragraph 3.28.)

~~4. GENERAL REQUIREMENTS~~

~~— This global technical regulation specifies the following tests to verify compliance of vehicles.~~

~~4.1. Legform test to bumper:~~

~~— For vehicles with a lower bumper height of less than 425 mm the requirements of paragraph 4.1.1. shall be applied.~~

~~— For vehicles with a lower bumper height which is both greater than, or equal to 425 mm and less than 500 mm the requirements of either paragraph 4.1.1. or 4.1.2., at the choice of the manufacturer, shall be applied.~~

~~— For vehicles with a lower bumper height of greater than, or equal to, 500 mm the requirements of paragraph 4.1.2. shall be applied.~~

~~4.1.1. Lower legform to bumper:~~

~~— To verify compliance with the performance requirements as specified in paragraph 5.1.1., both the test impactor specified in paragraph 6.3.1.1. and the test procedures specified in paragraph 7.1.1. shall be used.~~

~~4.1.2. Upper legform to bumper:~~

~~— To verify compliance with the performance requirements as specified in paragraph 5.1.2., both the test impactor specified in paragraph 6.3.1.2. and the test procedures specified in paragraph 7.1.2. shall be used.~~

~~4.2. Child headform impact:~~

~~— To verify compliance with the performance requirements as specified in paragraph 5.2.1., both the test impactor specified in paragraph 6.3.2.1. and the test procedures specified in paragraphs 7.2 and 7.3. shall be used.~~

~~4.3. Adult headform impact:~~

~~— To verify compliance with the performance requirements as specified in paragraph 5.2.2., both the test impactor specified in paragraph 6.3.2.2. and the test procedures specified in paragraphs 7.2. and 7.4. shall be used.~~

~~5. PERFORMANCE REQUIREMENTS~~

~~5.1. Legform to bumper:~~

~~5.1.1. — When tested in accordance with paragraph 7.1.1. (lower legform to bumper), the maximum dynamic knee bending angle shall not exceed 19°, the maximum dynamic knee shearing displacement shall not exceed 6.0 mm, and the acceleration~~

~~measured at the upper end of the tibia shall not exceed 170 g. In addition the manufacturer may nominate bumper test widths up to a maximum of 264 mm in total where the acceleration measured at the upper end of the tibia shall not exceed 250 g.~~

~~5.1.2. When tested in accordance with paragraph 7.1.2. (upper legform to bumper), the instantaneous sum of the impact forces with respect to time shall not exceed 7.5 kN and the bending moment on the test impactor shall not exceed 510 Nm.~~

~~5.2. Headform tests~~

~~5.2.1. Child headform to front structure:~~

~~When tested in accordance with paragraphs 7.2 and 7.3. the HIC shall comply with paragraph 5.2.3.~~

~~5.2.2. Adult headform to the front structure:~~

~~When tested in accordance with paragraph 7.2 and 7.4. the HIC shall comply with paragraph 5.2.3.~~

~~5.2.3. The HIC recorded shall not exceed 1,000 over a minimum of one half of the child headform test area and 1,000 over two third of the combined child and adult headform test areas. The HIC for the remaining areas shall not exceed 1,700 for both headforms.~~

~~In case there is only a child headform test area, the HIC recorded shall not exceed 1,000 over two third of the test area. For the remaining area the HIC shall not exceed 1,700.~~

~~5.2.4. Splitting of headform test zone~~

~~5.2.4.1. The manufacturer shall identify the zones of the bonnet top where the HIC must not exceed 1,000 (HIC1000 Zone) respectively 1,700 (HIC1700 Zone) (see Figure 11).~~

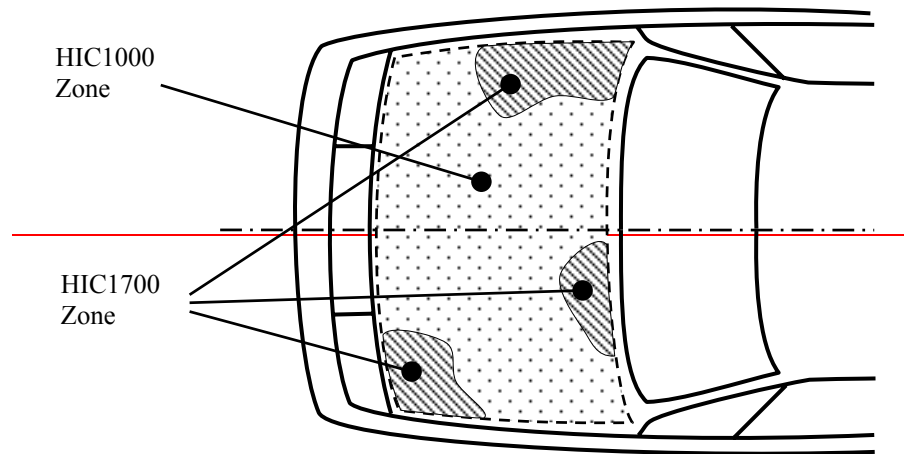

Figure 11: Example of marking of HIC1000 zone and HIC1700 zone

5.2.4.2. ~~Marking of the "bonnet top" impact area as well as "HIC1000 Zone" and "HIC1700 Zone" will be based on a drawing supplied by the manufacturer, when viewed from a horizontal plane above the vehicle that is parallel to the vehicle horizontal zero plane. A sufficient number of x and y co-ordinates shall be supplied by the manufacturer to mark up the areas on the actual vehicle while considering the vehicle outer contour in the z direction.~~

5.2.4.3. ~~The areas of "HIC1000 Zone" and "HIC1700 Zone" may consist of several parts, with the number of these parts not being limited.~~

5.2.4.4. ~~The calculation of the surface of the impact area as well as the surface areas of "HIC1000 Zone" and "HIC1700 Zone" shall be done on the basis of a projected bonnet when viewed from a horizontal plane parallel to the horizontal zero plane above the vehicle, on the basis of the drawing data supplied by the manufacturer.~~

~~6. TEST SPECIFICATIONS~~

~~6.1. General test conditions~~

~~6.1.1. Temperature and humidity~~

~~At the time of testing, the test facility and the vehicle or sub-system shall have a relative humidity of 40 per cent \pm 30 per cent and stabilized temperature of the be 20 ± 4 °C.~~

~~6.1.2. Impact test site~~

~~The test site shall consist of a flat, smooth and hard surface with a slope not exceeding 1 per cent.~~

~~6.2. Preparation of the vehicle~~

~~6.2.1. Either a complete vehicle, or a cut body, adjusted to the following conditions shall be used for the test.~~

~~6.2.1.1. The vehicle shall be in its normal ride attitude, and shall be either securely mounted on raised supports or at rest on a flat horizontal surface with the parking brake applied.~~

~~6.2.1.2. The cut body shall include, in the test, all parts of the vehicle front structure, all under-bonnet components and all components behind the windscreen that may be involved in a frontal impact with a vulnerable road user, to demonstrate the performance and interactions of all the contributory vehicle components. The cut body shall be securely mounted in the normal vehicle ride attitude.~~

~~6.2.2. All devices designed to protect vulnerable road users when impacted by the vehicle shall be correctly activated before and/or be active during the relevant test. It shall be the responsibility of the manufacturer to show that any devices will act as intended in a pedestrian impact.~~

~~6.2.3. For vehicle components which could change shape or position, other than active devices to protect pedestrians, and which have more than one fixed shape or position shall require the vehicle to comply with the components in each fixed shape or position.~~

~~6.3. Test impactor specifications~~

~~6.3.1. Legform impactors:~~

~~6.3.1.1. Lower legform impactor:~~

~~———— The lower legform impactor shall consist of two foam covered rigid segments, representing femur (upper leg) and tibia (lower leg), joined by a deformable, simulated knee joint. The overall length of the impactor shall be 926 ± 5 mm, having a required test mass of 13.4 ± 0.2 kg (see Figure 12).~~

~~———— Brackets, pulleys, etc. attached to the impactor for the purpose of launching it, may extend the dimensions shown in Figure 12.~~

~~6.3.1.1.1. The diameter of the femur and tibia shall be 70 ± 1 mm and both shall be covered by foam flesh and skin. The foam flesh shall be 25 mm thick Confor™ foam type CF-45 or equivalent. The skin shall be made of neoprene foam, faced with 0.5 mm thick nylon cloth both sides, with an overall thickness of 6 mm.~~

~~6.3.1.1.2. The knee joint shall be fitted with deformable knee elements from the same batch as those used in the certification tests.~~

- ~~6.3.1.1.3. The total masses of the femur and tibia shall be 8.6 ± 0.1 kg and 4.8 ± 0.1 kg respectively, and the total mass of the impactor shall be 13.4 ± 0.2 kg. The centre of gravity of the femur and tibia shall be 217 ± 10 mm and 233 ± 10 mm from the centre of the knee respectively. The moment of inertia of the femur and tibia, about a horizontal axis through the respective centre of gravity and perpendicular to the direction of impact, shall be 0.127 ± 0.010 kgm² and 0.120 ± 0.010 kgm² respectively.~~
- ~~6.3.1.1.4. For each test the impactor shall be fitted with new foam flesh cut from one of up to four consecutive sheets of Confor™ foam type CF-45 flesh material or equivalent, produced from the same batch of manufacture (cut from one block or 'bun' of foam), provided that foam from one of these sheets was used in the dynamic certification test and the individual weights of these sheets are within ± 2 per cent of the weight of the sheet used in the certification test.~~
- ~~6.3.1.1.5. The test impactor or at least the foam flesh shall be stored during a period of at least four hours in a controlled storage area with a stabilized humidity of 35 per cent ± 15 per cent and a stabilized temperature of $20 \pm 4^{\circ}\text{C}$ prior to impactor removal for calibration. After removal from the storage the impactor shall not be subjected to conditions other than those pertaining in the test area.~~
- ~~6.3.1.1.6. Lower legform instrumentation~~
- ~~6.3.1.1.6.1. A uniaxial accelerometer shall be mounted on the non impacted side of the tibia, 66 ± 5 mm below the knee joint centre, with its sensitive axis in the direction of impact.~~
- ~~6.3.1.1.6.2. A damper shall be fitted to the shear displacement system and may be mounted at any point on the rear face of the impactor or internally. The damper properties shall be such that the impactor meets both the static and dynamic shear displacement requirements and prevents excessive vibrations of the shear displacement system.~~
- ~~6.3.1.1.6.3. Transducers shall be fitted to measure knee bending angle and knee shearing displacement.~~
- ~~6.3.1.1.6.4. The instrumentation response value CFC, as defined in ISO 6487:2002, shall be 180 for all transducers. The CAC response values, as defined in ISO 6487:2002, shall be 50° for the knee bending angle, 10 mm for the shearing displacement and 500 g for the acceleration. This does not require that the impactor itself be able to physically bend and shear to these angles and displacements.~~
- ~~6.3.1.1.7. Lower legform certification~~
- ~~6.3.1.1.7.1. The lower legform impactor shall meet the performance requirements specified in paragraph 8.~~
- ~~6.3.1.1.7.2. The certified impactor may be used for a maximum of 20 impacts before re-certification. With each test new plastically deformable knee elements should be~~

~~used. The impactor shall also be re-certified if more than one year has elapsed since the previous certification, if any impactor transducer output, in any impact, has exceeded the specified CAC or has reached the mechanical limits of the leg impactor deformation capability.~~

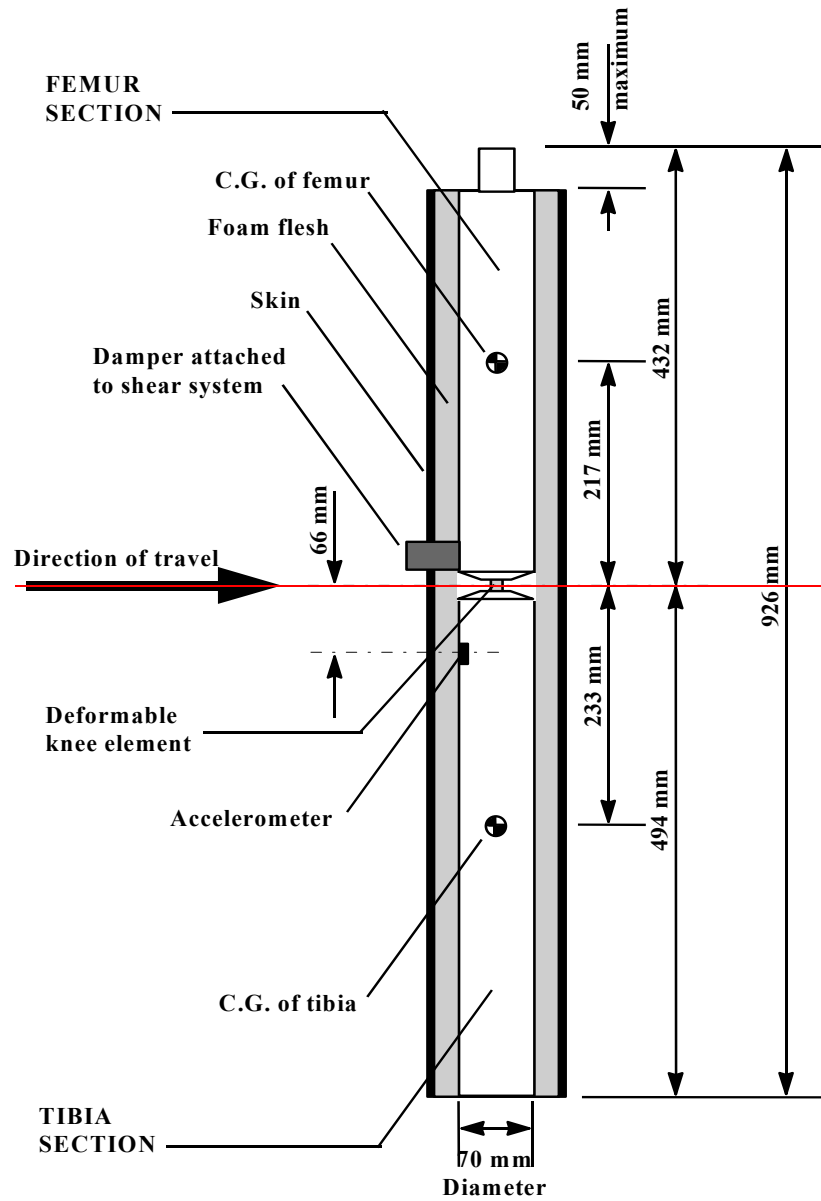

~~Figure 12: Lower legform impactor. (see paragraph 6.3.1.1.)~~

~~6.3.1.2. Upper legform impactor:~~

- ~~— The upper legform impactor shall be rigid, foam covered at the impact side, and 350 ± 5 mm long (see Figure 13).~~
- ~~6.3.1.2.1. The total mass of the upper legform impactor including those propulsion and guidance components which are effectively part of the impactor during the impact shall be $9.5 \text{ kg} \pm 0.1 \text{ kg}$.~~
- ~~6.3.1.2.2. The total mass of the front member and other components in front of the load transducer assemblies, together with those parts of the load transducer assemblies in front of the active elements, but excluding the foam and skin, shall be $1.95 \pm 0.05 \text{ kg}$.~~
- ~~6.3.1.2.3. The upper legform impactor for the bumper test shall be mounted to the propulsion system by a torque limiting joint and be insensitive to off-axis loading. The impactor shall move only in the specified direction of impact when in contact with the vehicle and shall be prevented from motion in other directions including rotation about any axis.~~
- ~~6.3.1.2.4. The torque limiting joint shall be set so that the longitudinal axis of the front member is vertical at the time of impact with a tolerance of $\pm 2^\circ$, with the joint friction torque set to $675 \text{ Nm} \pm 25 \text{ Nm}$.~~
- ~~6.3.1.2.5. The centre of gravity of those parts of the impactor which are effectively forward of the torque limiting joint, including any weights fitted, shall lie on the longitudinal centre line of the impactor, with a tolerance of $\pm 10 \text{ mm}$.~~
- ~~6.3.1.2.6. The length between the load transducer centre lines shall be $310 \pm 1 \text{ mm}$ and the front member diameter shall be $50 \pm 1 \text{ mm}$.~~
- ~~6.3.1.2.7. For each test the foam flesh shall be two new sheets of 25 mm thick ConforTM foam type CF 45 or equivalent, which shall be cut from the sheet of material used for the dynamic certification test. The skin shall be a 1.5 mm thick fibre reinforced rubber sheet. The foam and rubber skin together shall weigh $0.6 \pm 0.1 \text{ kg}$ (this excludes any reinforcement, mountings, etc. which are used to attach the rear edges of the rubber skin to the rear member). The foam and rubber skin shall be folded back towards the rear, with the rubber skin attached via spacers to the rear member so that the sides of the rubber skin are held parallel. The foam shall be of such a size and shape that an adequate gap is maintained between the foam and components behind the front member, to avoid significant load paths between the foam and these components.~~
- ~~6.3.1.2.8. The test impactor or at least the foam flesh shall be stored during a period of at least four hours in a controlled storage area with a stabilized humidity of 35 per cent ± 15 per cent and a stabilized temperature of $20 \pm 4^\circ\text{C}$ prior to impactor removal for calibration. After removal from the storage the impactor shall not be subjected to conditions other than those pertaining in the test area.~~

~~6.3.1.2.9. Upper legform instrumentation~~

~~6.3.1.2.9.1. The front member shall be strain gauged to measure bending moments in three positions, as shown in Figure 13, each using a separate channel. The strain gauges are located on the impactor on the back of the front member. The two outer strain gauges are located 50 ± 1 mm from the impactor's symmetrical axis. The middle strain gauge is located on the symmetrical axis with a ± 1 mm tolerance.~~

~~6.3.1.2.9.2. Two load transducers shall be fitted to measure individually the forces applied at either end of the upper legform impactor, plus strain gauges measuring bending moments at the centre of the upper legform impactor and at positions 50 mm either side of the centre line, (see Figure 13).~~

~~6.3.1.2.9.3. The instrumentation response value CFC, as defined in ISO 6487:2002, shall be 180 for all transducers. The CAC response values, as defined in ISO 6487:2002, shall be 10 kN for the force transducers and 1000 Nm for the bending moment measurements.~~

~~6.3.1.2.10. Upper legform certification~~

~~6.3.1.2.10.1. The upper legform impactor shall meet the performance requirements specified in paragraph 8.~~

~~6.3.1.2.10.2. The certified impactor may be used for a maximum of 20 impacts before re-certification (this limit does not apply to propulsion or guidance components). The impactor shall also be re-certified if more than one year has elapsed since the previous certification or if any impactor transducer output, in any impact, has exceeded the specified CAC.~~

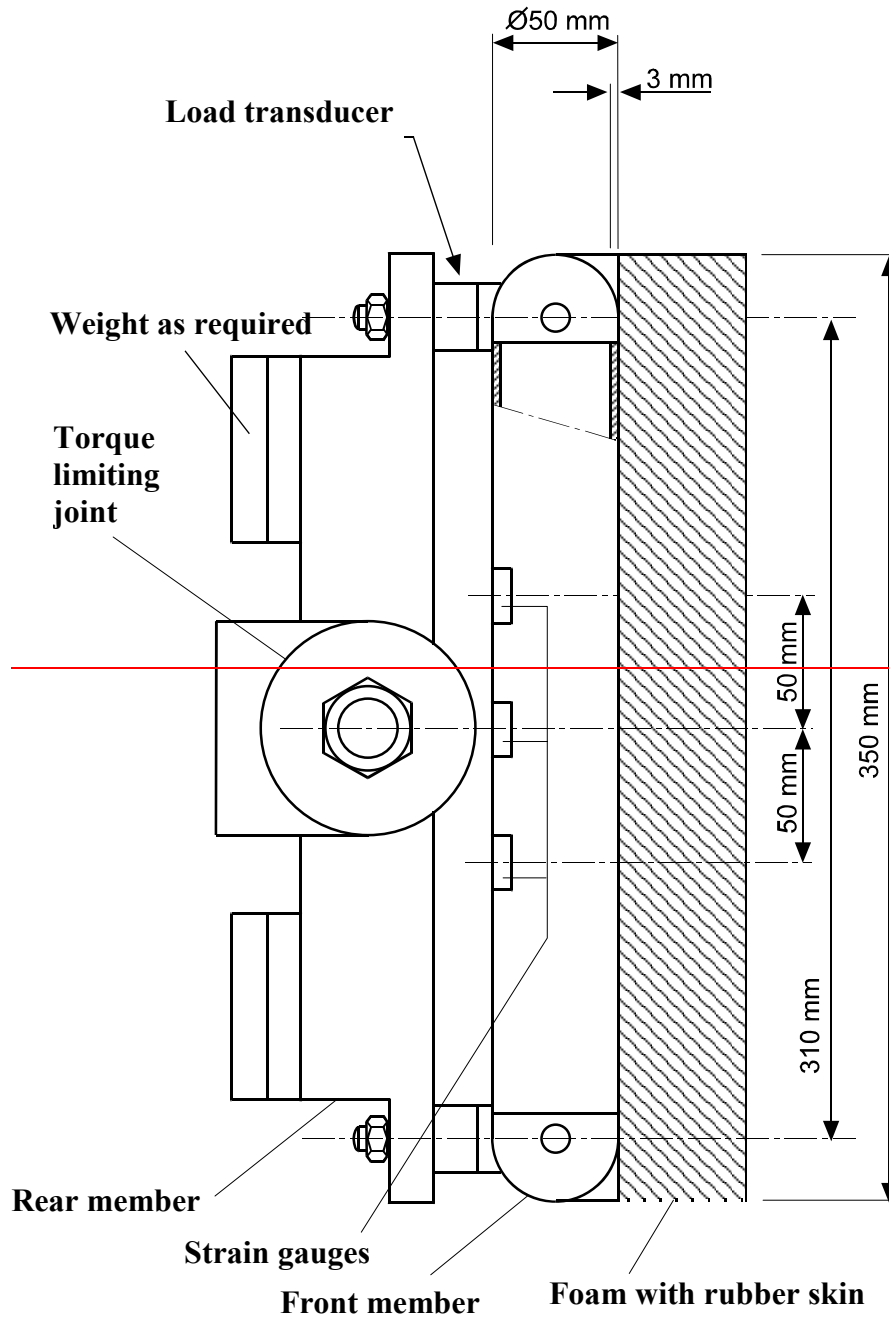

Figure 13: Upper legform impactor (see paragraph 6.3.1.2.)

6.3.2. Child and adult headform impactors

6.3.2.1. Child headform impactor (see Figure 14)

The child headform impactor shall be made of aluminium, be of homogenous construction and be of spherical shape. The overall diameter shall be 165 ± 1 mm. The mass shall be 3.5 ± 0.07 kg. The moment of inertia about an axis through the centre of gravity and perpendicular to the direction of impact shall be within the range of 0.008 to 0.012 kgm². The centre of gravity of the headform impactor

including instrumentation shall be located in the geometric centre of the sphere with a tolerance of ± 2 mm.

~~The sphere shall be covered with a 14 ± 0.5 mm thick synthetic skin, which shall cover at least half of the sphere.~~

~~6.3.2.1.1. Child headform instrumentation~~

~~A recess in the sphere shall allow for mounting one triaxial or three uniaxial accelerometers within ± 10 mm seismic mass location tolerance from the centre of the sphere for the measurement axis, and ± 1 mm seismic mass location tolerance from the centre of the sphere for the perpendicular direction to the measurement axis.~~

~~If three uniaxial accelerometers are used, one of the accelerometers shall have its sensitive axis perpendicular to the mounting face A (see Figure 14) and its seismic mass shall be positioned within a cylindrical tolerance field of 1 mm radius and 20 mm length. The centre line of the tolerance field shall run perpendicular to the mounting face and its mid-point shall coincide with the centre of the sphere of the headform impactor.~~

~~The remaining accelerometers shall have their sensitive axes perpendicular to each other and parallel to the mounting face A and their seismic mass shall be positioned within a spherical tolerance field of 10 mm radius. The centre of the tolerance field shall coincide with the centre of the sphere of the headform impactor.~~

~~The instrumentation response value CFC, as defined in ISO 6487: 2002, shall be 1,000. The CAC response value, as defined in ISO 6487: 2002, shall be 500 g for the acceleration.~~

~~6.3.2.1.2. First natural frequency~~

~~The first natural frequency of the headform impactor shall be over 5,000 Hz.~~

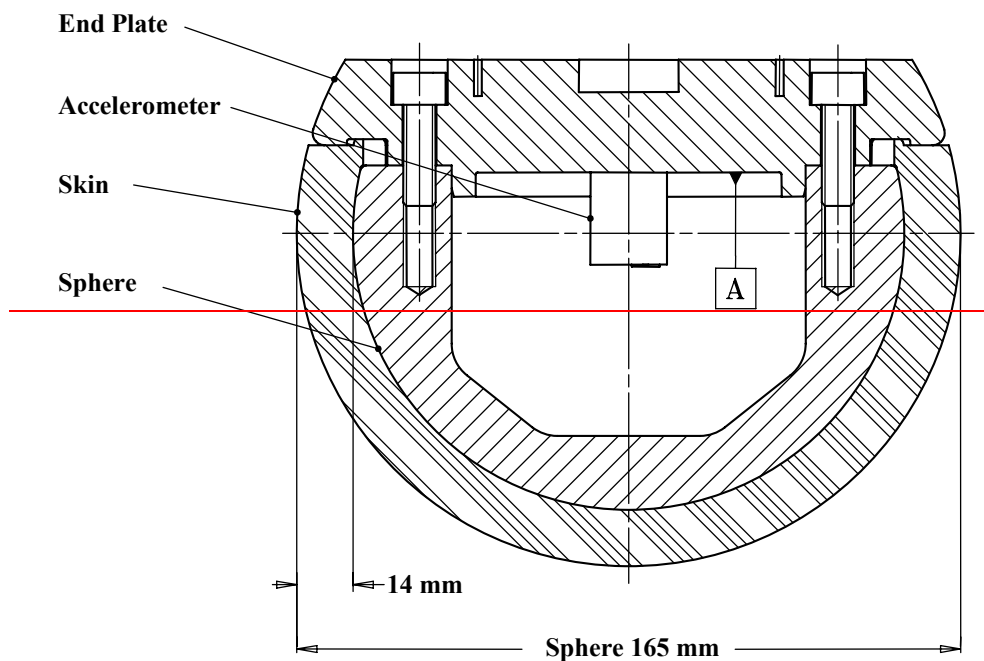

Figure 14: ~~Child headform impactor (see paragraph 6.3.2.1.)~~

~~6.3.2.2. Adult headform impactor (see Figure 15)~~

~~The adult headform impactor shall be made of aluminium, be of homogenous construction and be of spherical shape. The overall diameter is 165 ± 1 mm as shown in Figure 15. The mass shall be 4.5 ± 0.1 kg. The moment of inertia about an axis through the centre of gravity and perpendicular to the direction of impact shall be within the range of 0.010 to 0.013 kgm^2 . The centre of gravity of the headform impactor including instrumentation shall be located in the geometric centre of the sphere with a tolerance of ± 5 mm.~~

~~The sphere shall be covered with a 14 ± 0.5 mm thick synthetic skin, which shall cover at least half of the sphere.~~

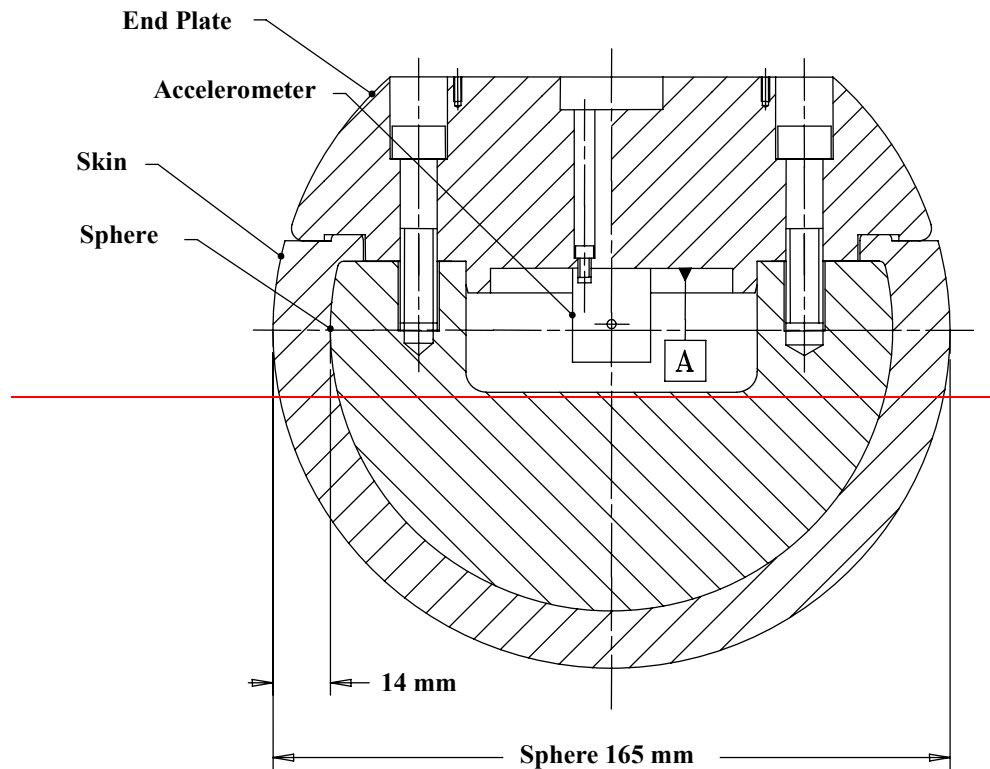

Figure 15: ~~Adult headform impactor (see paragraph 6.3.2.2)~~

6.3.2.2.1. ~~Adult headform instrumentation~~

- ~~A recess in the sphere shall allow for mounting one triaxial or three uniaxial accelerometers within ± 10 mm seismic mass location tolerance from the centre of the sphere for the measurement axis, and ± 1 mm seismic mass location tolerance from the centre of the sphere for the perpendicular direction to the measurement axis.~~
- ~~If three uniaxial accelerometers are used, one of the accelerometers shall have its sensitive axis perpendicular to the mounting face A (see Figure 15) and its seismic mass shall be positioned within a cylindrical tolerance field of 1 mm radius and 20 mm length. The centre line of the tolerance field shall run perpendicular to the mounting face and its mid point shall coincide with the centre of the sphere of the headform impactor.~~
- ~~The remaining accelerometers shall have their sensitive axes perpendicular to each other and parallel to the mounting face A and their seismic mass shall be positioned within a spherical tolerance field of 10 mm radius. The centre of the tolerance field shall coincide with the centre of the sphere of the headform impactor.~~

~~———— The instrumentation response value CFC, as defined in ISO 6487: 2002, shall be 1,000. The CAC response value, as defined in ISO 6487: 2002, shall be 500 g for the acceleration.~~

~~6.3.2.2.2. First natural frequency~~

~~———— The first natural frequency of the headform impactor shall be over 5,000 Hz.~~

~~6.3.2.3. Rear face of the headform impactors~~

~~———— A rear flat face shall be provided on the outer surface of the headform impactors which is perpendicular to the direction of travel, and typically perpendicular to the axis of one of the accelerometers as well as being a flat plate capable of providing for access to the accelerometers and an attachment point for the propulsion system.~~

~~6.3.2.4. Certification of the headform impactors~~

~~———— The headform impactors shall meet the performance requirements specified in paragraph 8. The certified impactors may be used for a maximum of 20 impacts before re-certification. The impactors shall be re-certified if more than one year has elapsed since the previous certification or if the transducer output, in any impact, has exceeded the specified CAC.~~

~~7. TEST PROCEDURES~~

~~7.1. Legform to bumper test procedures~~

~~7.1.1. Lower legform to bumper test procedure:~~

~~———— Each test shall be completed within two hours of when the impactor to be used is removed from the controlled storage area.~~

~~7.1.1.1. The selected target points shall be in the bumper test area.~~

~~7.1.1.2. The direction of the impact velocity vector shall be in the horizontal plane and parallel to the longitudinal vertical plane of the vehicle. The tolerance for the direction of the velocity vector in the horizontal plane and in the longitudinal plane shall be $\pm 2^\circ$ at the time of first contact. The axis of the impactor shall be perpendicular to the horizontal plane with a tolerance of $\pm 2^\circ$ in the lateral and longitudinal plane. The horizontal, longitudinal and lateral planes are orthogonal to each other (see Figure 16).~~

~~7.1.1.3. The bottom of the impactor shall be at 25 mm above ground reference level at the time of first contact with the bumper (see Figure 17), with a ± 10 mm tolerance. When setting the height of the propulsion system, an allowance must be made for the influence of gravity during the period of free flight of the impactor.~~

- ~~7.1.1.3.1. The lower legform impactor for the bumper tests shall be in 'free flight' at the moment of impact. The impactor shall be released to free flight at such a distance from the vehicle that the test results are not influenced by contact of the impactor with the propulsion system during rebound of the impactor.~~
- ~~———— The impactor may be propelled by an air, spring or hydraulic gun, or by other means that can be shown to give the same result.~~
- ~~7.1.1.3.2. At the time of first contact the impactor shall have the intended orientation about its vertical axis, for the correct operation of its knee joint, with a tolerance of $\pm 5^\circ$ (see Figure 16).~~
- ~~7.1.1.3.3. At the time of first contact the centre line of the impactor shall be within a ± 10 mm tolerance to the selected impact location.~~
- ~~7.1.1.3.4. During contact between the impactor and the vehicle, the impactor shall not contact the ground or any object which is not part of the vehicle.~~
- ~~7.1.1.4. The impact velocity of the impactor when striking the bumper shall be 11.1 ± 0.2 m/s. The effect of gravity shall be taken into account when the impact velocity is obtained from measurements taken before the time of first contact.~~

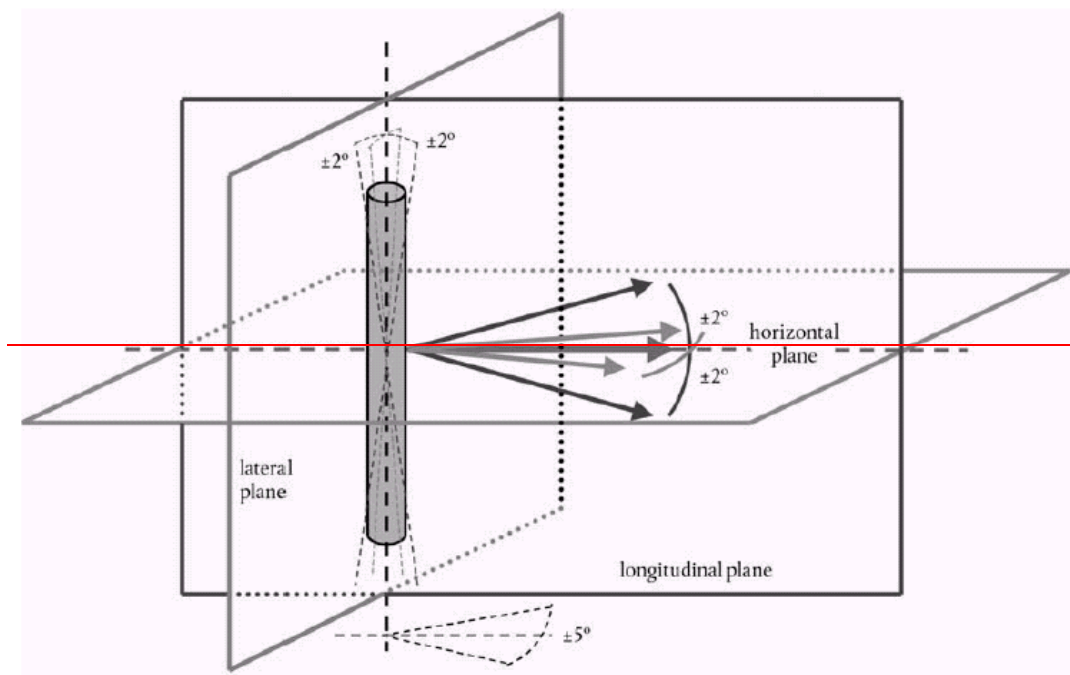

~~Figure 16: Tolerances of angles for the lower legform impactor at the time of the first impact (see paragraphs 7.1.1.2 and 7.1.1.3.2.)~~

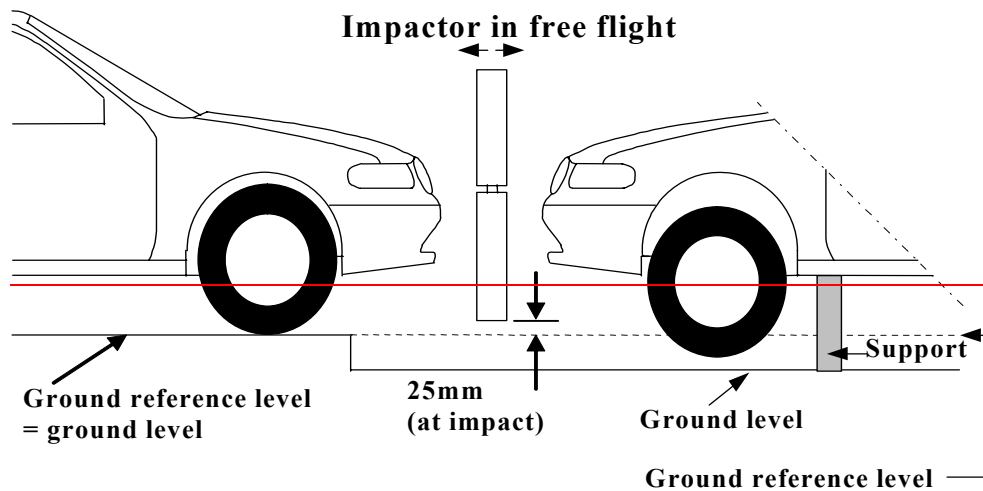

Figure 17: Lower legform to bumper tests for complete vehicle in normal ride attitude (left) and for cut body mounted on supports (right) (see paragraph 7.1.1.3)

7.1.2. Upper legform to bumper test procedure:

Each test shall be completed within two hours of when the impactor to be used is removed from the controlled storage area.

7.1.2.1. The selected target points shall be in the bumper test area as defined in paragraph 3.10.

7.1.2.2. The direction of impact shall be parallel to the longitudinal axis of the vehicle, with the axis of the upper legform vertical at the time of first contact. The tolerance to this direction is $\pm 2^\circ$.

At the time of first contact the impactor centre line shall be vertically midway between the upper bumper reference line and the lower bumper reference line with a ± 10 mm tolerance and laterally with the selected impact location with a tolerance of ± 10 mm.

7.1.2.3. The impact velocity of the upper legform impactor when striking the bumper shall be 11.1 ± 0.2 m/s.

7.2. Headform test procedures

7.2.1. Propulsion of the headform impactors

The headform impactors shall be in "free flight" at the moment of impact, at the required impact velocity (as specified in paragraphs 7.3.4. and 7.4.4.) and the required direction of impact (as specified in paragraphs 7.3.5. and 7.4.5.).

~~————— The impactors shall be released to "free flight" at such a distance from the vehicle that the test results are not influenced by contact of the impactor with the propulsion system during rebound of the impactor.~~

~~7.2.2. Measurement of impact velocity~~

~~————— The velocity of the headform impactor shall be measured at some point during the free flight before impact, in accordance with the method specified in ISO 3784:1976. The accuracy of velocity measurement shall be ± 0.01 m/sec. The measured velocity shall be adjusted considering all factors which may affect the impactor between the point of measurement and the point of impact, in order to give the velocity of the impactor at the time of impact. The angle of the velocity vector at the time of impact shall be calculated or measured.~~

~~7.2.3. Recording~~

~~————— The acceleration time histories shall be recorded, and HIC shall be calculated. The first point of contact on the front structure of the vehicle shall be recorded. Recording of test results shall be in accordance with ISO 6487:2002.~~

~~7.3. Child headform test procedure~~

~~————— This test procedure is applicable with respect to the requirements of paragraphs 5.2.1. and 5.2.3.~~

~~7.3.1. Tests shall be made to the front structure within the boundaries as defined in paragraph 3.12. For tests on the rear area of the bonnet top, the headform impactor shall not contact the windscreen or A pillar before impacting the bonnet top.~~

~~7.3.2. No impact point shall be located so that the impactor will impact the test area with a glancing blow resulting in a more severe second impact outside the test area.~~

~~————— Selected impact points on the bonnet for the child headform impactor shall be, at the time of first contact:~~

- ~~————— (1) a minimum of 82.5 mm inside the defined side reference lines, and;~~
- ~~————— (2) forward of the WAD1700 line, or,~~
 - ~~————— a minimum of 82.5 mm forwards of the bonnet rear reference line,~~
 - ~~————— whichever is most forward at the point of measurement, and;~~
- ~~————— (3) be rearward of the WAD1000 line, or,~~
 - ~~————— a minimum of 82.5 mm rearwards of the bonnet leading edge reference line,~~
 - ~~————— whichever is most rearward at the point of measurement.~~

~~————— These minimum distances are to be set with a flexible tape held tautly along the outer surface of the vehicle.~~

~~7.3.3. The point of first contact of the headform impactor shall be within a ± 10 mm tolerance to the selected impact point.~~

~~7.3.4. The headform velocity at the time of impact shall be 9.7 ± 0.2 m/s.~~

~~7.3.5. The direction of impact shall be in the longitudinal vertical plane of the vehicle to be tested at an angle of $50 \pm 2^\circ$ to the horizontal. The direction of impact of tests to the front structure shall be downward and rearward.~~

~~7.4. Adult headform test procedure:~~

~~— This test procedure is applicable with respect to the requirements of paragraphs 5.2.2. and 5.2.3.~~

~~7.4.1. Tests shall be made to the front structure within the boundaries as defined in paragraph 3.1. For tests at the rear of the bonnet top, the headform impactor shall not contact the windscreen or A-pillar before impacting the bonnet top.~~

~~7.4.2. No impact point shall be located so that the impactor will impact the test area with a glancing blow resulting in a more severe second impact outside the test area.~~

~~— Selected impact points on the bonnet for the adult headform impactor shall be, at the time of first contact:~~

- ~~— (1) a minimum of 82.5 mm inside the defined side reference lines, and;~~
- ~~— (2) forward of the WAD2100 line, or,~~
- ~~— a minimum of 82.5 mm forward of the bonnet rear reference line,~~
- ~~— whichever is most forward at the point of measurement, and;~~
- ~~— (3) rearward of the WAD1700 line.~~

~~— These minimum distances are to be set with a flexible tape held tautly along the outer surface of the vehicle.~~

~~7.4.3. The point of first contact of the headform impactor shall be within a ± 10 mm tolerance to the selected impact point.~~

~~7.4.4. The headform velocity at the time of impact shall be 9.7 ± 0.2 m/s.~~

~~7.4.5. The direction of impact shall be in the fore and aft vertical plane of the paragraph of the vehicle to be tested at an angle of $65^\circ \pm 2^\circ$ to the horizontal. The direction of impact of tests to the front structure shall be downward and rearward.~~

~~8. CERTIFICATION OF IMPACTORS~~

~~— The impactors that are used in the tests described in this gtr are required to comply with the following performance requirements.~~

~~— The requirements for the lower legform impactor are specified in paragraph 8.1., the upper legform impactor requirements are specified in paragraph 8.2. and the adult and child headform impactors requirements are specified in paragraph 8.3.~~

~~8.1. Lower legform impactor certification~~

~~8.1.1. Static tests~~

~~8.1.1.1. The lower legform impactor shall meet the requirements specified in paragraph 8.1.1.2. when tested as specified in paragraph 8.1.1.4. and the requirements specified in paragraph 8.1.1.3. when tested as specified in paragraph 8.1.1.5.~~

~~For both tests the impactor shall have the intended orientation about its longitudinal axis, for the correct operation of its knee joint, with a tolerance of $\pm 2^\circ$.~~

~~The stabilized temperature of the impactor during certification shall be $20^\circ \pm 2^\circ\text{C}$.~~

~~The CAC response values, as defined in ISO 6487:2002 shall be 50° for the knee bending angle and 500 N for the applied force when the impactor is loaded in bending in accordance with paragraph 8.1.1.4., and 10 mm for the shearing displacement and 10 kN for the applied force when the impactor is loaded in shearing in accordance with paragraph 8.1.1.5. For both tests low pass filtering at an appropriate frequency is permitted, to remove higher frequency noise without significantly affecting the measurement of the response of the impactor.~~

~~8.1.1.2. When the impactor is loaded in bending in accordance with paragraph 8.1.1.4., the applied force/bending angle response shall be within the limits shown in Figure 18. Also, the energy taken to generate 15.0° of bending shall be 100 ± 7 J.~~

~~8.1.1.3. When the impactor is loaded in shearing in accordance with paragraph 8.1.1.5., the applied force/shearing displacement response shall be within the limits shown in Figure 19.~~

~~8.1.1.4. The impactor, without foam covering and skin, shall be mounted with the tibia firmly clamped to a fixed horizontal surface and a metal tube connected firmly to the femur, as shown in Figure 20. To avoid friction errors, no support shall be provided to the femur section or the metal tube. The bending moment applied at the centre of the knee joint, due to the weight of the metal tube and other components (excluding the legform itself), shall not exceed 25 Nm.~~

~~A horizontal normal force shall be applied to the metal tube at a distance of 2.0 ± 0.01 m from the centre of the knee joint and the resulting angle of knee deflection shall be recorded. The load shall be increased until the angle of deflection of the knee is in excess of 22° .~~

~~The energy is calculated by integrating the force with respect to the bending angle in radians, and multiplying by the lever length of 2.0 ± 0.01 m.~~

~~8.1.1.5. The impactor, without foam covering and skin, shall be mounted with the tibia firmly clamped to a fixed horizontal surface and a metal tube connected firmly to~~

~~the femur and restrained at 2.0 m from the centre of the knee joint, as shown in Figure 21.~~

~~A horizontal normal force shall be applied to the femur at a distance of 50 mm from the centre of the knee joint and the resulting knee shearing displacement shall be recorded. The load shall be increased until the shearing displacement of the knee is in excess of 8.0 mm or the load is in excess of 6.0 kN.~~

~~8.1.2. Dynamic tests~~

~~8.1.2.1. The lower legform impactor shall meet the requirements specified in paragraph 8.1.2.3. when tested as specified in paragraph 8.1.2.4.~~

~~8.1.2.2. Calibration~~

~~8.1.2.2.1. The foam flesh for the test impactor shall be stored during a period of at least four hours in a controlled storage area with a stabilized humidity of 35 ± 10 per cent and a stabilized temperature of $20 \pm 2^\circ\text{C}$ prior to impactor removal for calibration. The test impactor itself shall have a temperature of $20^\circ \pm 2^\circ\text{C}$ at the time of impact. The temperature tolerances for the test impactor shall apply at a relative humidity of 40 ± 30 per cent after a soak period of at least four hours prior to their application in a test.~~

~~8.1.2.2.2. The test facility used for the calibration test shall have a stabilized humidity of 40 ± 30 per cent and a stabilized temperature of $20 \pm 4^\circ\text{C}$ during calibration.~~

~~8.1.2.2.3. Each calibration shall be completed within two hours of when the impactor to be calibrated is removed from the controlled storage area.~~

~~8.1.2.2.4. Relative humidity and temperature of the calibration area shall be measured at the time of calibration and recorded in a calibration report.~~

~~8.1.2.3. Requirements~~

~~8.1.2.3.1. When the impactor is impacted by a linearly guided certification impactor, as specified in paragraph 8.1.2.4., the maximum upper tibia acceleration shall be not less than 120 g and not more than 250 g. The maximum bending angle shall be not less than 6.2° and not more than 8.2° . The maximum shearing displacement shall be not less than 3.5 mm and not more than 6.0 mm.~~

~~For all these values, the readings used shall be from the initial impact with the certification impactor and not from the arresting phase. Any system used to arrest the impactor or certification impactor shall be so arranged that the arresting phase does not overlap in time with the initial impact. The arresting system shall not cause the transducer outputs to exceed the specified CAC.~~

~~8.1.2.3.2. The instrumentation response value CFC, as defined in ISO 6487:2002, shall be 180 for all transducers. The CAC response values, as defined in ISO 6487:2002, shall~~

~~be 50° for the knee bending angle, 10 mm for the shearing displacement and 500 g for the acceleration. This does not require that the impactor itself be able to physically bend and shear to these angles and displacements.~~

~~8.1.2.4. Test procedure~~

~~8.1.2.4.1. The impactor, including foam covering and skin, shall be suspended horizontally by three wire ropes of 1.5 ± 0.2 mm diameter and of 2000 mm minimum length, as shown in Figure 22. It shall be suspended with its longitudinal axis horizontal, with a tolerance of $\pm 0.5^\circ$, and perpendicular to the direction of the certification impactor motion, with a tolerance of $\pm 2^\circ$. The impactor shall have the intended orientation about its longitudinal axis, for the correct operation of its knee joint, with a tolerance of $\pm 2^\circ$. The impactor must meet the requirements of paragraph 6.3.1.1., with the attachment bracket(s) for the wire ropes fitted.~~

~~8.1.2.4.2. The certification impactor shall have a mass of 9.0 ± 0.05 kg, this mass includes those propulsion and guidance components which are effectively part of the impactor during impact. The dimensions of the face of the certification impactor shall be as specified in Figure 23. The face of the certification impactor shall be made of aluminium, with an outer surface finish of better than 2.0 micrometers.~~

~~The guidance system shall be fitted with low friction guides, insensitive to off-axis loading, that allow the impactor to move only in the specified direction of impact, when in contact with the vehicle. The guides shall prevent motion in other directions including rotation about any axis.~~

~~8.1.2.4.3. The impactor shall be certified with previously unused foam.~~

~~8.1.2.4.4. The impactor foam shall not be excessively handled or deformed before, during or after fitting.~~

~~8.1.2.4.5. The certification impactor shall be propelled horizontally at a velocity of 7.5 ± 0.1 m/s into the stationary impactor as shown in Figure 23. The certification impactor shall be positioned so that its centreline aligns with a position on the tibia centreline of 50 mm from the centre of the knee, with tolerances of ± 3 mm laterally and ± 3 mm vertically.~~

~~8.2. Upper legform impactor certification~~

~~8.2.1. The upper legform impactor shall meet the requirements specified in paragraph 8.2.3 when tested as specified in paragraph 8.2.4.~~

~~8.2.2. Calibration~~

~~8.2.2.1. The foam flesh for the test impactor shall be stored during a period of at least four hours in a controlled storage area with a stabilized humidity of 35 ± 10 per cent and a stabilized temperature of $20^\circ \pm 2^\circ\text{C}$ prior to impactor removal for calibration. The test impactor itself shall have a temperature of $20^\circ \pm 2^\circ\text{C}$ at the time of impact. The~~

~~temperature tolerances for the test impactor shall apply at a relative humidity of 40 ± 30 per cent after a soak period of at least four hours prior to their application in a test.~~

~~8.2.2.2. The test facility used for the calibration test shall have a stabilized humidity of 40 ± 30 per cent and a stabilized temperature of $20^\circ \pm 4^\circ\text{C}$ during calibration.~~

~~8.2.2.3. Each calibration shall be completed within two hours of when the impactor to be calibrated is removed from the controlled storage area.~~

~~8.2.2.4. Relative humidity and temperature of the calibration area shall be measured at the time of calibration, and recorded in a calibration report.~~

~~8.2.3. Requirements~~

~~8.2.3.1. When the impactor is propelled into a stationary cylindrical pendulum the peak force measured in each load transducer shall be not less 1.20 kN and not more than 1.55 kN and the difference between the peak forces measured in the top and bottom load transducers shall not be more than 0.10 kN. Also, the peak bending moment measured by the strain gauges shall not be less than 190 Nm and not more than 250 Nm on the centre position and not less than 160 Nm and not more than 220 Nm for the outer positions. The difference between the upper and lower peak bending moments shall not be more than 20 Nm.~~

~~For all these values the readings used shall be from the initial impact with the pendulum and not from the arresting phase. Any system used to arrest the impactor or pendulum shall be so arranged that the arresting phase does not overlap in time with the initial impact. The arresting system shall not cause the transducer outputs to exceed the specified CAC.~~

~~8.2.3.2. The instrumentation response value CFC, as defined in ISO 6487:2002, shall be 180 for all transducers. The CAC response values, as defined in ISO 6487:2002, shall be 10 kN for the force transducers and 1000 Nm for the bending moment measurements.~~

~~8.2.4. Test procedure~~

~~8.2.4.1. The impactor shall be mounted to the propulsion and guidance system, by a torque limiting joint. The torque limiting joint shall be set so that the longitudinal axis of the front member is perpendicular to the axis of the guidance system, with a tolerance of $\pm 2^\circ$, with the joint friction torque set to 675 ± 25 Nm. The guidance system shall be fitted with low friction guides that allow the impactor to move only in the specified direction of impact, when in contact with the pendulum.~~

~~8.2.4.2. The impactor mass shall be adjusted to give a mass of 12 ± 0.1 kg, this mass includes those propulsion and guidance components which are effectively part of the impactor during impact.~~

- ~~8.2.4.3. The centre of gravity of those parts of the impactor which are effectively forward of the torque limiting joint, including the extra weights fitted, shall lie on the longitudinal centreline of the impactor, with a tolerance of ± 10 mm.~~
- ~~8.2.4.4. The impactor shall be certified with previously unused foam.~~
- ~~8.2.4.5. The impactor foam shall not be excessively handled or deformed before, during or after fitting.~~
- ~~8.2.4.6. The impactor with the front member vertical shall be propelled horizontally at a velocity of 7.1 ± 0.1 m/s into the stationary pendulum as shown in Figure 24.~~
- ~~8.2.4.7. The pendulum tube shall have a mass of 3 ± 0.03 kg, a wall thickness of 3 ± 0.15 mm and an outside diameter of $150 \text{ mm}^{+1 \text{ mm}} / -4 \text{ mm}$. Total pendulum tube length shall be 275 ± 25 mm. The pendulum tube shall be made from cold finished seamless steel (metal surface plating is permissible for protection from corrosion), with an outer surface finish of better than 2.0 micrometer. It shall be suspended on two wire ropes of 1.5 ± 0.2 mm diameter and of 2.0 m minimum length. The surface of the pendulum shall be clean and dry. The pendulum tube shall be positioned so that the longitudinal axis of the cylinder is perpendicular to the front member (i.e. level), with a tolerance of $\pm 2^\circ$, and to the direction of impactor motion, with a tolerance of $\pm 2^\circ$, and with the centre of the pendulum tube aligned with the centre of the impactor front member, with tolerances of ± 5 mm laterally and ± 5 mm vertically.~~

~~8.3. Child and adult headform impactors certification~~

~~8.3.1. Drop test~~

~~8.3.1.1. Performance Criteria~~

~~— The headform impactors shall meet the requirements specified in paragraph 8.3.2. when tested as specified in paragraph 8.3.3.~~

~~8.3.2. Requirements~~

~~8.3.2.1. When the headform impactors are dropped from a height of 376 ± 1 mm in accordance with paragraph 8.3.3. the peak resultant acceleration measured by one triaxial (or three uniaxial) accelerometer (accelerometers) in the headform impactor shall be:~~

~~— for the child headform impactor not less than 245 g and not more than 300 g;~~

~~— for the adult headform impactor not less than 225 g and not more than 275 g.~~

~~— The acceleration time curve shall be uni-modal.~~

~~8.3.2.2. The instrumentation response values CFC and CAC for each accelerometer shall be 1000 Hz and 500 g respectively as defined in ISO 6487:2002.~~

~~8.3.2.3. Temperature conditions~~

- ~~———— The headform impactors shall have a temperature of $20 \pm 2^{\circ}\text{C}$ at the time of impact. The temperature tolerances shall apply at a relative humidity of 40 ± 30 per cent after a soak period of at least four hours prior to their application in a test.~~
- ~~8.3.2.4. — After complying with the certification test, each headform impactor can be used for a maximum of 20 impact tests.~~
- ~~8.3.3. — Test Procedure~~
- ~~8.3.3.1. — The headform impactor shall be suspended from a drop rig as shown in Figure 25.~~
- ~~8.3.3.2. — The headform impactor shall be dropped from the specified height by means that ensure instant release onto a rigidly supported flat horizontal steel plate, over 50 mm thick and over 300 mmsquare which has a clean dry surface and a surface finish of between 0.2 and 2.0 micrometers.~~
- ~~8.3.3.3. — The headform impactor shall be dropped with the rear face of the impactor at the test angle specified in paragraph 7.3.5. for the child headform impactor and in paragraph 7.4.5. for the adult headform impactor with respect to the vertical as shown in Figure 25. The suspension of the headform impactor shall be such that it does not rotate during the fall.~~
- ~~8.3.3.4. — The drop test shall be performed three times, with the headform impactor rotated 120° around its symmetrical axis after each test.~~

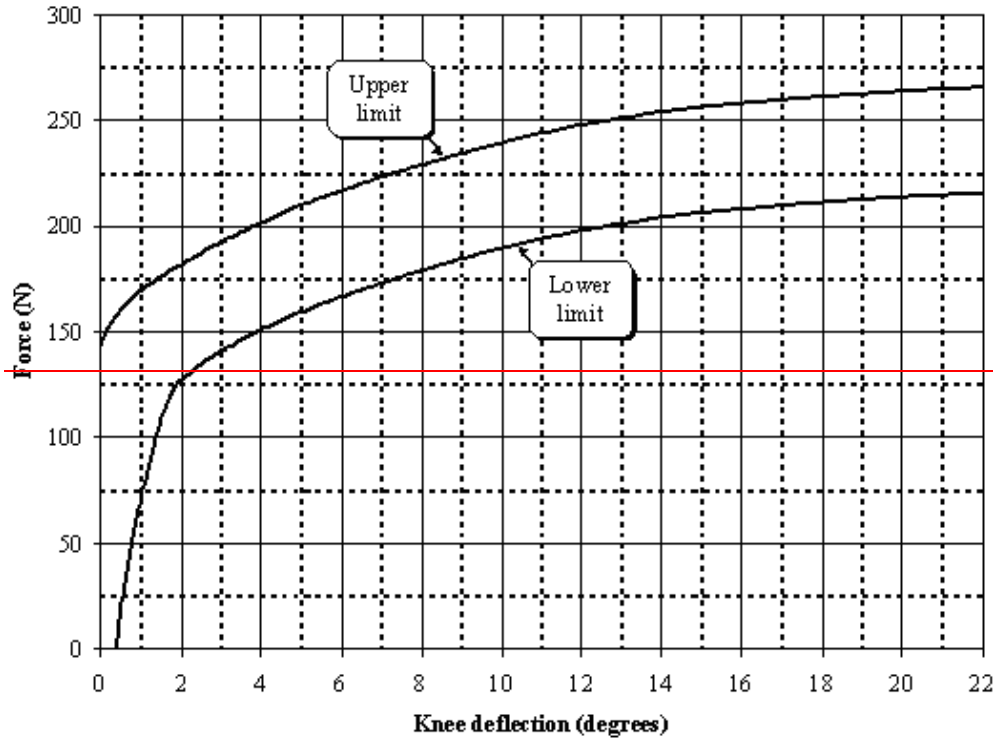

Figure 18. Force versus angle requirement in static lower legform impactor bending certification test (see paragraph 8.1.1.2.)

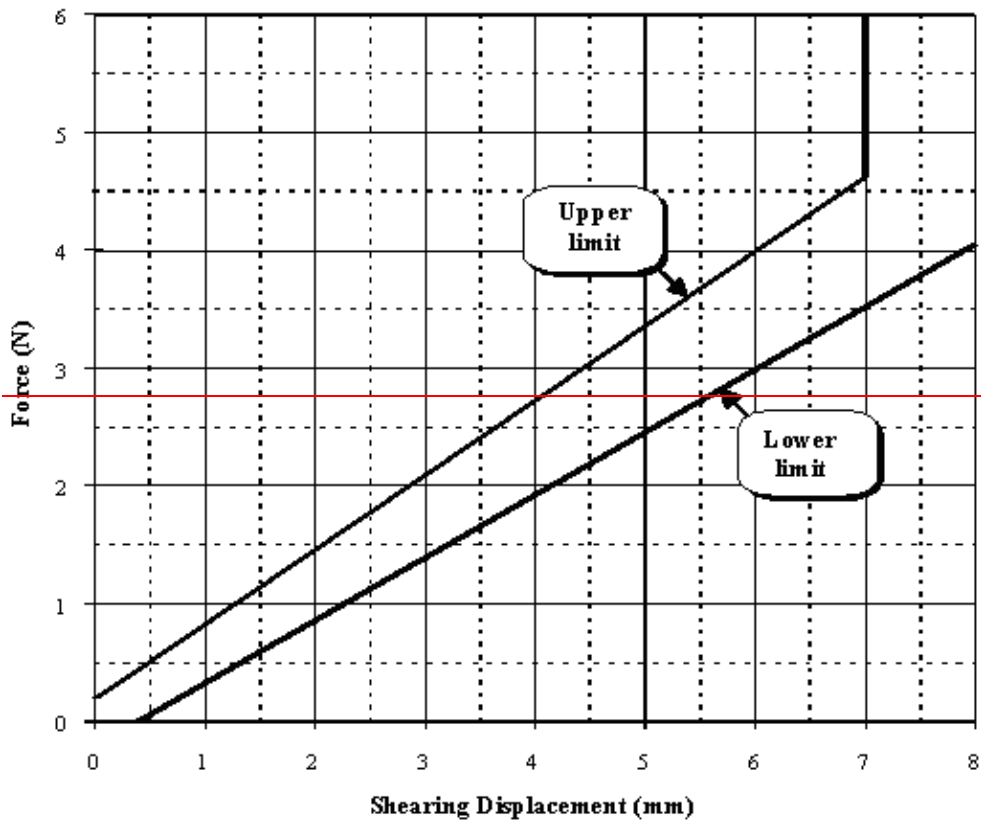

Figure 19. Force versus displacement requirement in static lower legform impactor shearing certification test (see paragraph 8.1.1.3.)

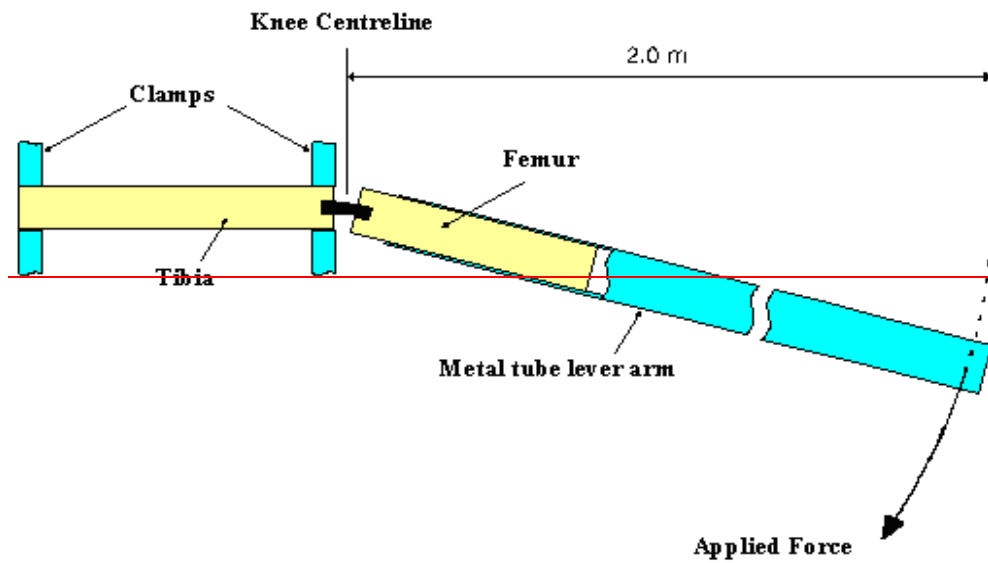

Figure 20. — Top View of Test set-up for static lower legform impactor bending certification test (see paragraph 8.1.1.4.)

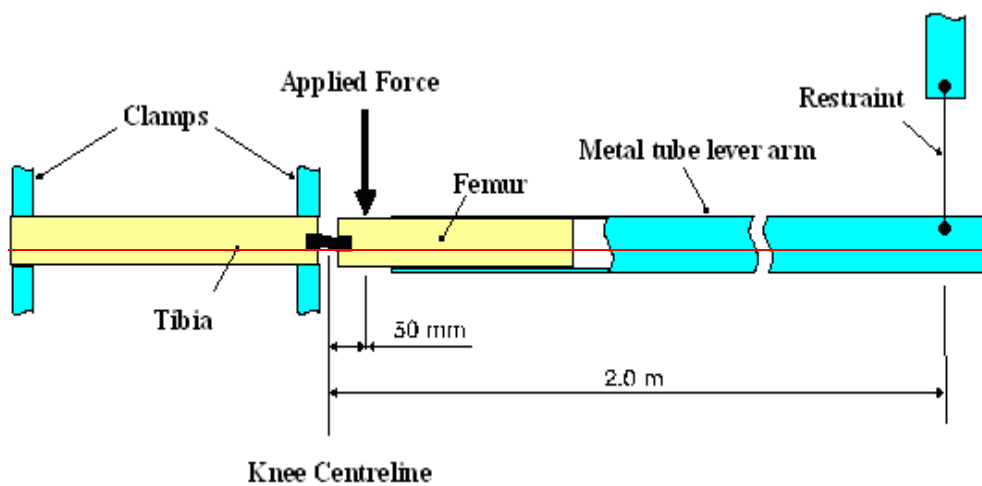

Figure 21. — Top View of Test set-up for static lower legform impactor shearing certification test (see paragraph 8.1.1.5.)

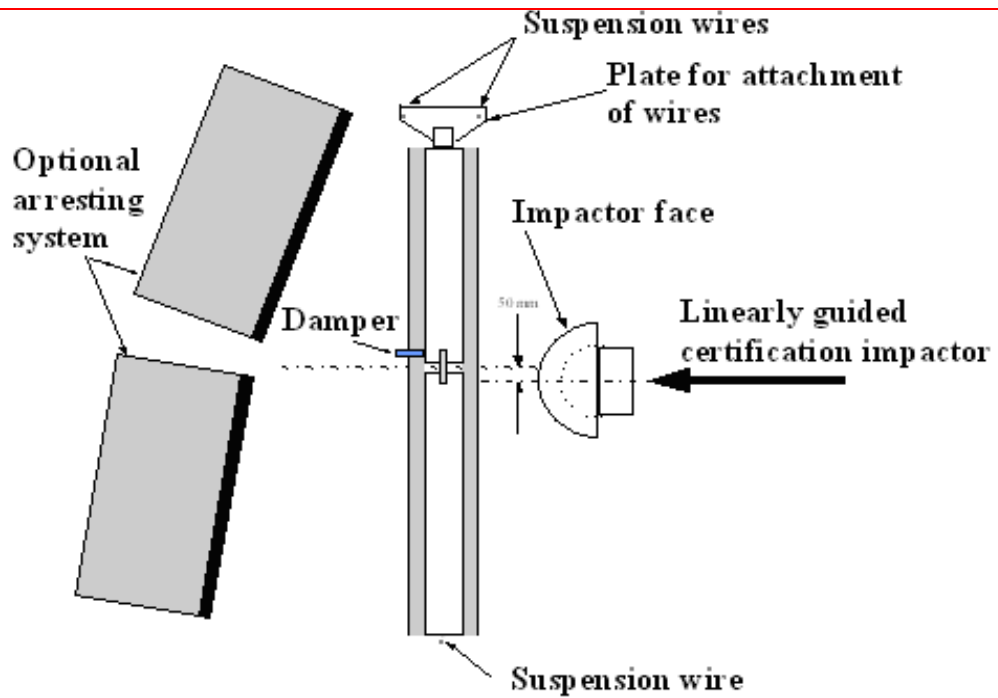
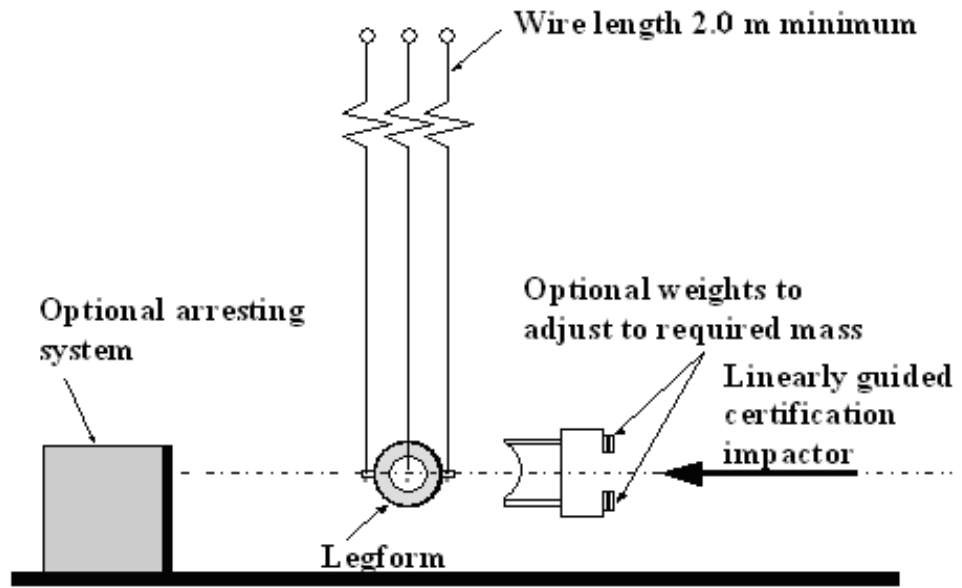

Figure 22. — Test set-up for dynamic lower legform impactor certification test (side view top diagram, view from above bottom diagram) (see paragraph 8.1.2.5.1.)

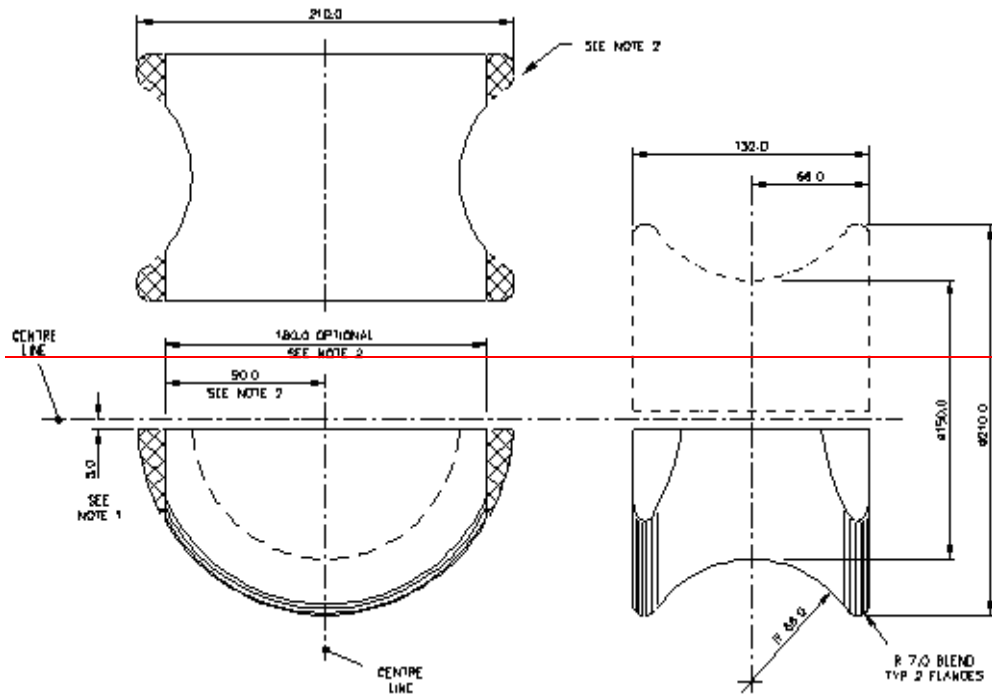

Figure 23. — Details of dynamic lower legform certification impactor face (see paragraph 8.1.2.5.2.)

Notes:

1. — Saddle may be made as a complete diameter and cut as shown to make two components.
 2. — The shaded areas may be removed to give the alternative form shown.
 3. — Tolerance on all dimensions is ± 1.0 mm.
- Material: Aluminium alloy.

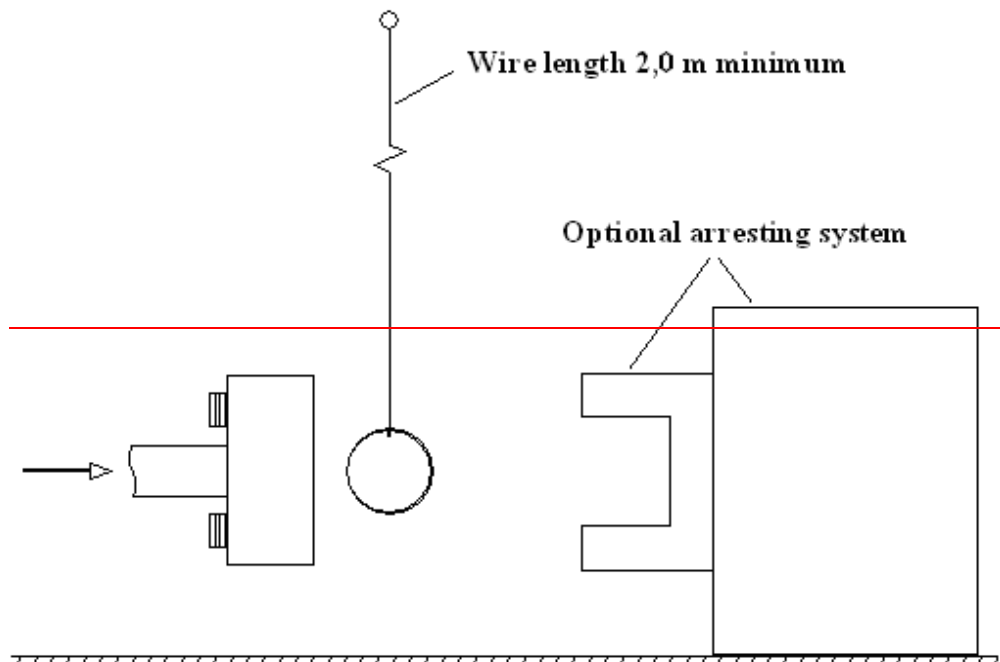

Figure 24. — Test set-up for dynamic upper legform impactor certification test
(see paragraph 8.2.4.6)

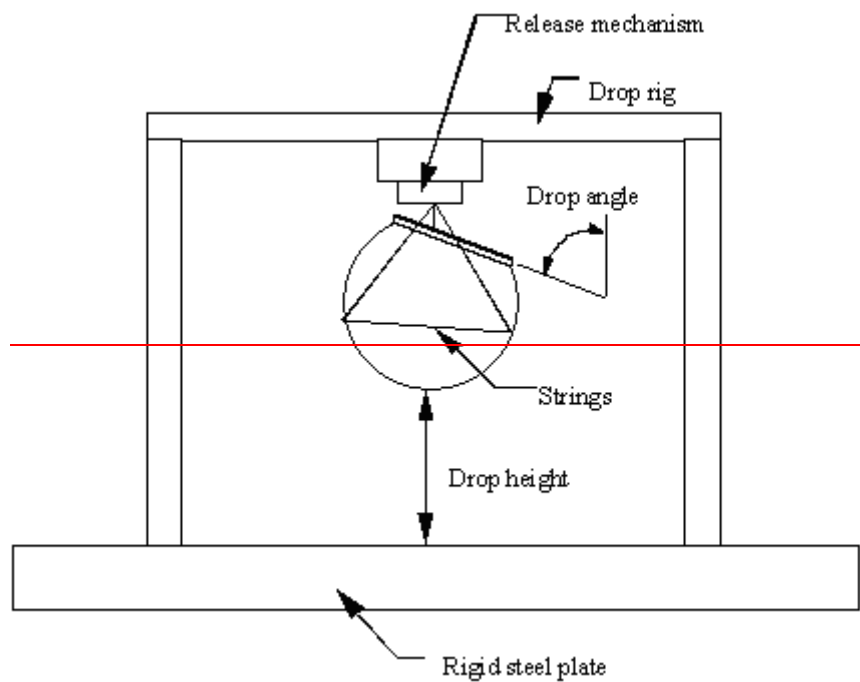

Figure 25. — Test set-up for dynamic headform impactor biofidelity test
(see paragraph 8.3.3.1.)

contact, while in light truck and van impacts, 72 per cent of the knee and lower leg injuries were attributed to bumper contact. Based on these proportions, the number of pedestrians with AIS 2-6 lower extremity injuries that could potentially be addressed by the gtr□

Estimated number of pedestrians with AIS 2+ lower extremity injuries addressed by regulation caused by vehicle covered by regulation:

= (number of annual LE MAIS 2+ injured pedestrians) x (percentage to knee and lower leg) x (percentage sustained by vehicle type x percentage of vehicle type covered by regulation x percentage attributed to bumper contact by vehicle)

= 15,994 x 0.56 x (0.84 x 1.00 x 0.81 + 0.16 x 0.87 x 0.72)

= 6,992 pedestrians with AIS 2-6 knee or lower leg injury as highest severity injury impacted by vehicle bumper covered by regulation

Lower leg benefits

The United States of America calculated benefits based on experimental testing of 5 vehicles 23/ in collaboration with Transport Canada. An estimate based on the geometry of the 5 bumpers tested showed that the total testable area on the bumpers was approximately 80 per cent of their width. The 264 mm relaxation zone of the bumper that is required to meet the less stringent 250 g requirement is approximately 15 per cent of the total bumper width on average. The remaining primary test area of the bumper covered by the more stringent 170 g requirement is approximately 65 per cent. Results from the testing estimated 42 per cent improvement to the overall AIS 2-6 knee and lower leg injury risk in the primary test area and 14 per cent improvement in the relaxation zone. Accordingly, the knee and lower leg injuries prevented by the gtr:

AIS 2+ knee and lower leg injuries prevented:

= (target population) x (improvement_{primary} x test zone_{primary} + improvement_{relax} x test zone_{relax})

= 6,992 x (0.42 x 0.65 + 0.14 x 0.15)

= 2,056

As stated above the testable percentage of the bumper was estimated to be 80 per cent, about 10 per cent of which is outboard of the gtr-defined bumper "corner". This area is generally oriented laterally and would therefore not be expected to deliver a direct blow to a pedestrian leg. In fact, it is expected that the vast majority of lower extremity impacts would occur between the bumper corners, suggesting that closer to 90 per cent of all bumper-related injuries occur with the testable area, rather than the 80 per cent estimated in these calculations. If the higher testable area number were used, the injuries prevented would be expected to increase by approximately 10 per cent.

As a result of these conservatively low estimates of target population, improvement as a result of gtr requirements, and testable area, these estimates of injuries prevented should be considered as the minimum likely benefit from the gtr requirements.

23/ Mallory A, Stammen JA, Legault F. "Component Leg Testing of Vehicle Front Structures," Paper No. 05-0194, Nineteenth International Technical Conference on the Enhanced Safety of Vehicles, June 2005.

(b) Costs

The added cost per vehicle to meet requirements of this gtr is estimated to be approximately 45 Euros (63 U.S. Dollars). For minivans this is estimated to be around 32.50 Euros (45.50 US Dollars). The EU feasibility study (INF GR/PS/89) also addressed small sports cars with the conclusion that for these vehicles the cost could be substantially higher i.e. up to 410 Euros (574 US Dollars) due to the perceived need for popup bonnets. Industry representatives to the informal working group indicated that the majority of these costs, but at least up to two-thirds, will result from the head protection requirements, and only the rest will result from the leg protection requirements.

APPENDIX – REFERENCE DOCUMENTS USED BY THE WORKING GROUP

A list of working papers used by the informal working group is listed and available on the UNECE WP.29 website (<http://www.unece.org/trans/main/welcwp29.htm>).

<u>Number of working paper</u>	<u>Title of informal document</u>
<u>INF GR/PS/1 and Rev 1</u>	<u>Agenda 1st meeting</u>
<u>INF GR/PS/2</u>	<u>Terms of reference</u>
<u>INF GR/PS/3</u>	<u>IHRA accident study presentation</u>
<u>INF GR/PS/4 and Rev 1</u>	<u>JMLIT proposed legislation</u>
<u>INF GR/PS/5</u>	<u>IHRA feasibility study</u>
<u>INF GR/PS/6</u>	<u>J information on possible scope</u>
<u>INF GR/PS/7</u>	<u>Attendance list 1st meeting</u>
<u>INF GR/PS/8 and Rev 1</u>	<u>Draft Meeting Minutes 1st meeting</u>
<u>INF GR/PS/9 and Rev 1</u>	<u>Report to GRSP 32 inf doc</u>
<u>INF GR/PS/10</u>	<u>Draft action plan</u>
<u>INF GR/PS/11</u>	<u>Agenda 2nd meeting</u>
<u>INF GR/PS/12</u>	<u>GIDAS accident data</u>
<u>INF GR/PS/13</u>	<u>GIDAS accident data graphs</u>
<u>INF GR/PS/14</u>	<u>Italian accident data</u>
<u>INF GR/PS/15</u>	<u>UN accident data</u>
<u>INF GR/PS/16</u>	<u>Spanish accident data</u>
<u>INF GR/PS/17</u>	<u>ACEA accident data</u>
<u>INF GR/PS/18</u>	<u>Draft Meeting Minutes 2nd meeting</u>
<u>INF GR/PS/19</u>	<u>Agenda 3rd meeting</u>
<u>INF GR/PS/20</u>	<u>Canadian accident data</u>
<u>INF GR/PS/21</u>	<u>Netherlands accident data</u>
<u>INF GR/PS/22</u>	<u>Scope overview</u>
<u>INF GR/PS/23</u>	<u>Draft content table preliminary report</u>
<u>INF GR/PS/24</u>	<u>Attendance list 3rd meeting</u>
<u>INF GR/PS/25</u>	<u>GIDAS presentation</u>
<u>INF GR/PS/26</u>	<u>Leg injuries ITARDA</u>
<u>INF GR/PS/27 and Rev 1</u>	<u>Draft Meeting Minutes 3rd meeting</u>
<u>INF GR/PS/28</u>	<u>Technical feasibility general</u>
<u>INF GR/PS/29</u>	<u>Infrastructure effectiveness</u>
<u>INF GR/PS/30</u>	<u>Pelvis / Femur fracture</u>
<u>INF GR/PS/31</u>	<u>IHRA/PS-WG Pedestrian accident data</u>
<u>INF GR/PS/32</u>	<u>ESV summary paper on IHRA/PS-WG report</u>
<u>INF GR/PS/33</u>	<u>Introduction of the regulation of pedestrian head protection in Japan; Nishimoto, Toshiyuki</u>

<u>Number of working paper</u>	<u>Title of informal document</u>
<u>INF GR/PS/34</u>	<u>Proposal for a directive of the European Parliament and the Council relating to the protection of pedestrians and other vulnerable road users in the event of a collision with a motor vehicle and amending Directive 70/156/EEC; Commission of the European Communities, Brussels, February 2003</u>
<u>INF GR/PS/35</u>	<u>List of conflicts with existing legislation / requirements</u>
<u>INF GR/PS/36</u>	<u>Draft preliminary report</u>
<u>INF GR/PS/37</u>	<u>Agenda 4th meeting</u>
<u>INF GR/PS/38</u>	<u>Technical prescriptions concerning test provisions for pedestrian safety</u>
<u>INF GR/PS/39 and Rev 1</u>	<u>Vehicle safety standards report 1</u>
<u>INF GR/PS/40</u>	<u>US Cumulative 2002 Fleet GVMR</u>
<u>INF GR/PS/41</u>	<u>Swedish accident data</u>
<u>INF GR/PS/42</u>	<u>TRANS/WP.29/GRSG/2003/10 proposal for common definitions</u>
<u>INF GR/PS/43</u>	<u>Category 1-1 GVM</u>
<u>INF GR/PS/44</u>	<u>Light duty truck</u>
<u>INF GR/PS/45</u>	<u>EURO-NCAP results and what they mean in relation to EU Phase 1</u>
<u>INF GR/PS/46</u>	<u>JAMA / JARI child and adult head impactors</u>
<u>INF GR/PS/47 and Rev 1</u>	<u>Preliminary report to GRSP 33</u>
<u>INF GR/PS/48 and Rev 1</u>	<u>Draft meeting minutes 4th meeting</u>
<u>INF GR/PS/49</u>	<u>IHRA child head test method</u>
<u>INF GR/PS/50</u>	<u>IHRA adult head test method</u>
<u>INF GR/PS/51</u>	<u>Attendance list 4th meeting</u>
<u>INF GR/PS/52</u>	<u>Provisional agenda for the 5th meeting</u>
<u>INF GR/PS/53</u>	<u>Draft gtr format</u>
<u>INF GR/PS/54</u>	<u>gtr proposal to WP29</u>
<u>INF GR/PS/55</u>	<u>Draft gtr</u>
<u>INF GR/PS/56 and Rev 1</u>	<u>Comparison table</u>
<u>INF GR/PS/57</u>	<u>Proposed schedule of the group</u>
<u>INF GR/PS/58</u>	<u>Presentation on veh shape, bound line, ...</u>
<u>INF GR/PS/59</u>	<u>A-pillar IHRA OICA presentation</u>
<u>INF GR/PS/60</u>	<u>ISO/TC22/SC10/WG2 N613</u>
<u>INF GR/PS/61</u>	<u>IHRA PS 237</u>
<u>INF GR/PS/62</u>	<u>Action plan from 5 meeting</u>
<u>INF GR/PS/63</u>	<u>Attendance list 5th meeting</u>
<u>INF GR/PS/64 and Rev 1</u>	<u>Draft meeting minutes 5th meeting</u>
<u>INF GR/PS/65 and Rev 1</u>	<u>Provisional agenda for the 6th meeting</u>
<u>INF GR/PS/66</u>	<u>AUS-NCAP pedestrian data</u>
<u>INF GR/PS/67</u>	<u>Test-method - active hood / bonnet systems</u>
<u>INF GR/PS/68</u>	<u>Target population head injuries - US</u>
<u>INF GR/PS/69</u>	<u>Working paper draft gtr</u>

<u>Number of working paper and Rev 1</u>	<u>Title of informal document</u>
<u>INF GR/PS/70</u>	<u>Korean information</u>
<u>INF GR/PS/71</u>	<u>Head test area windscreen + A-pillar</u>
<u>INF GR/PS/72</u>	<u>Head test data on windscreen</u>
<u>INF GR/PS/73</u>	<u>Head impact angle / speed re-assessment based on vehicle geometry</u>
<u>INF GR/PS/74</u>	<u>IHRA/PS/270 headform impactor specification</u>
<u>INF GR/PS/75</u>	<u>Powerpoint explanation of PS/67</u>
<u>INF GR/PS/76</u>	<u>IHRA legform discussions</u>
<u>INF GR/PS/77</u>	<u>Corridors proposed by UVA (lower legform)</u>
<u>INF GR/PS/78</u>	<u>Bio rating method: Maltese</u>
<u>INF GR/PS/79</u>	<u>IHRA antropometric proposal</u>
<u>INF GR/PS/80</u>	<u>IHRA/PS/278</u>
<u>INF GR/PS/81</u>	<u>Schedule for legform impactor for gtr</u>
<u>INF GR/PS/82</u>	<u>Injury threshold for ped legform test</u>
<u>INF GR/PS/83</u>	<u>Decided items and action items of the 6th meeting</u>
<u>INF GR/PS/84</u>	<u>Draft meeting minutes of the 6th meeting</u>
<u>INF GR/PS/85</u>	<u>Attendance list of the 6th meeting</u>
<u>INF GR/PS/86 and Rev 1 / 2</u>	<u>Draft gtr EU working document</u>
<u>INF GR/PS/87</u>	<u>IHRA PS 273 Development of FlexPLI2003</u>
<u>INF GR/PS/88</u>	<u>Second interim report to GRSP 35</u>
<u>INF GR/PS/89</u>	<u>EU Feasibility Study Phase 2</u>
<u>INF GR/PS/90</u>	<u>Provisional agenda for the 7th meeting</u>
<u>INF GR/PS/91</u>	<u>ACEA feasibility study Phase 2</u>
<u>INF GR/PS/92</u>	<u>ACEA equal effectiveness study Phase 2</u>
<u>INF GR/PS/93</u>	<u>Design of head impactor</u>
<u>INF GR/PS/94</u>	<u>Front windshield</u>
<u>INF GR/PS/95</u>	<u>JPN comment on PS 86 Rev 2 + English text of Japanese technical standard</u>
<u>INF GR/PS/96</u>	<u>Problem of undamped accelerometer</u>
<u>INF GR/PS/97</u>	<u>Durability and repeatability of headform skin</u>
<u>INF GR/PS/98</u>	<u>IHRA PS 310 decision for legform test</u>
<u>INF GR/PS/99</u>	<u>Skin aging of head impactor</u>
<u>INF GR/PS/100</u>	<u>OICA proposed amendments to PS/95</u>
<u>INF GR/PS/101</u>	<u>JAMA feasibility study Phase 2</u>
<u>INF GR/PS/102</u>	<u>OICA windscreen testing according to EURO-NCAP protocol</u>
<u>INF GR/PS/103</u>	<u>CLEPA windscreen testing on one car model</u>
<u>INF GR/PS/104</u>	<u>Draft CLEPA / OICA document on active bonnet testing</u>
<u>INF GR/PS/105</u>	<u>Lower leg research for developing corridors</u>
<u>INF GR/PS/106</u>	<u>J-MLIT proposal for FlexPLI answering item 9 of PS/83</u>
<u>INF GR/PS/107</u>	<u>NHTSA proposal for guidelines of preamble</u>
<u>INF GR/PS/108</u>	<u>JAMA information on high bumper definition</u>
<u>INF GR/PS/109</u>	<u>Chairman proposal for FlexPLI and rigid impactor use in gtr</u>
<u>INF GR/PS/110</u>	<u>OICA proposal for side and rear windscreen reference line</u>
<u>INF GR/PS/111 and Rev 1</u>	<u>Guideline for preamble</u>

<u>Number of working paper</u>	<u>Title of informal document</u>
<u>INF GR/PS/112</u>	<u>Action plan</u>
<u>INF GR/PS/113</u>	<u>Revision of draft gtr</u>
<u>INF GR/PS/114</u>	<u>Attendance list</u>
<u>INF GR/PS/115 and Rev 1</u>	<u>Draft meeting minutes of the 7th meeting</u>
<u>INF GR/PS/116</u>	<u>Cleaned up version of draft gtr</u>
<u>INF GR/PS/117</u>	<u>Preamble and draft gtr off doc for GRSP 37</u>
<u>INF GR/PS/118 and Rev 1</u>	<u>Provisional agenda for the 8th meeting</u>
<u>INF GR/PS/119</u>	<u>ISO Activities for Pedestrian Safety</u>
<u>INF GR/PS/120</u>	<u>EC final feasibility study</u>
<u>INF GR/PS/121</u>	<u>GRSP/2005/3 as amended during GRSP/37</u>
<u>INF GR/PS/122</u>	<u>GRSP-37-18</u>
<u>INF GR/PS/123</u>	<u>GRSP-37-15</u>
<u>INF GR/PS/124</u>	<u>GRSP-37-16</u>
<u>INF GR/PS/125</u>	<u>Short report on comments received during GRSP-37</u>
<u>INF GR/PS/126</u>	<u>July meeting task list</u>
<u>INF GR/PS/127</u>	<u>Presentation on EU Phase 2</u>
<u>INF GR/PS/128</u>	<u>The need for harmonized legislation on pedestrian protection</u>
<u>INF GR/PS/129</u>	<u>Comparison between the J standard and the EU Phase 2 proposal for head testing</u>
<u>INF GR/PS/130</u>	<u>List of references for EU / EEVC on head impact angles</u>
<u>INF GR/PS/131</u>	<u>Analysis of pedestrian accident situation and portion addressed by this gtr</u>
<u>INF GR/PS/132</u>	<u>gtr testing and what it means for the US situation</u>
<u>INF GR/PS/133 and Rev 1</u>	<u>Proposal to solve the undamped accelerometer problem</u>
<u>INF GR/PS/134</u>	<u>Concerns on §7.4 with testing on the centre of the windscreen</u>
<u>INF GR/PS/135</u>	<u>OICA proposal for §3.33</u>
<u>INF GR/PS/136</u>	<u>OICA proposal for a mass for the upper leg impactor</u>
<u>INF GR/PS/137</u>	<u>OICA proposal on definition of high bumper vehicles</u>
<u>INF GR/PS/138</u>	<u>Economic effectiveness study from Korea</u>
<u>INF GR/PS/139</u>	<u>Action list of 8th meeting</u>
<u>INF GR/PS/140</u>	<u>IHRA Injury breakdown background document for PS/131</u>
<u>INF GR/PS/141</u>	<u>Update of PS67 on certification standard for deployable systems</u>
<u>INF GR/PS/142</u>	<u>Relative humidity of Korea</u>
<u>INF GR/PS/143 and Rev 1</u>	<u>Draft gtr based on INF GR / PS / 121 as amended during the 8th meeting</u>
<u>INF GR/PS/144 and Rev 1</u>	<u>Draft meeting minutes of the 8th meeting</u>
<u>INF GR/PS/145</u>	<u>Attendance list 8th meeting</u>
<u>INF GR/PS/146</u>	<u>Flex-TEG Activities updating PS 124</u>
<u>INF GR/PS/147</u>	<u>Actions 1 3 4 6 9 of 8th meeting</u>
<u>INF GR/PS/148</u>	<u>Action 9 of 8th meeting doc FTSS_4[1].5kg_headform</u>
<u>INF GR/PS/149</u>	<u>Adult headform moment of inertia</u>
<u>INF GR/PS/150</u>	<u>Development of a head impact test, Glaeser</u>

<u>Number of working paper</u>	<u>Title of informal document</u>
<u>INF GR/PS/151</u>	<u>gtr preamble for accelerometer</u>
<u>INF GR/PS/152</u>	<u>Provisional agenda for the 9th meeting</u>
<u>INF GR/PS/153</u>	<u>Explanation of amendments from PS143 to PS143 Rev1</u>
<u>INF GR/PS/154 and Rev 1</u>	<u>Handling guide for the TRL leg</u>
<u>INF GR/PS/155</u>	<u>LWRL definition</u>
<u>INF GR/PS/156</u>	<u>Impact angles for headform to windscreen tests</u>
<u>INF GR/PS/157</u>	<u>HIC limits for headform to windscreen tests</u>
<u>INF GR/PS/158</u>	<u>Headform to bonnet tests</u>
<u>INF GR/PS/159</u>	<u>Definition high bumper vehicles</u>
<u>INF GR/PS/160</u>	<u>Revised preamble replacing the preamble in PS/143 Rev 1</u>
<u>INF GR/PS/161 and Rev 1 / 2</u>	<u>EU proposed amendments to 143 Rev 1</u>
<u>INF GR/PS/162</u>	<u>Explanation of EU proposals to amend R143 Rev 1</u>
<u>INF GR/PS/163</u>	<u>Windscreen impact testing</u>
<u>INF GR/PS/164</u>	<u>Windscreen fracture modes</u>
<u>INF GR/PS/165</u>	<u>Leg feasibility testing</u>
<u>INF GR/PS/166</u>	<u>Relaxation zone and GVWR application</u>
<u>INF GR/PS/167</u>	<u>EU field data on crossbeam height</u>
<u>INF GR/PS/168</u>	<u>HIC15 vs HIC36 headaccel analysis</u>
<u>INF GR/PS/169</u>	<u>Revising PS 131 ~ Analysis of Pedestrian Accident and gtr Application</u>
<u>INF GR/PS/170</u>	<u>Target population for this gtr</u>
<u>INF GR/PS/171</u>	<u>Draft meeting minutes of the 9th meeting</u>
<u>INF GR/PS/172</u>	<u>Attendance list 9th meeting</u>
<u>INF GR/PS/173</u>	<u>Provisional agenda for the 10th meeting</u>
<u>INF GR/PS/174 and Rev 1</u>	<u>Lower leg tests - EuroNCAP data - OICA presentation for Jan 06 meeting</u>
<u>INF GR/PS/175 and Rev 1 / 2</u>	<u>Bumper Reference Lines - OICA presentation for Jan 06 meeting</u>
<u>INF GR/PS/176 and Rev 1 / 2</u>	<u>Headform test results - OICA presentation for Jan 06 meeting</u>
<u>INF GR/PS/177</u>	<u>IHRA-PS Proposal for the Moment of Inertia of gtr Adult-Child Headform Impactors</u>
<u>INF GR/PS/178</u>	<u>Expected life-saving effect gtr Head Japan</u>
<u>INF GR/PS/179</u>	<u>Ongoing Researches on Pedestrian Leg Injuries Assessment</u>
<u>INF GR/PS/180</u>	<u>OICA position on the change of the definition of the ble reference line</u>
<u>INF GR/PS/181</u>	<u>Comparison lower leg injuries for different AIS levels</u>
<u>INF GR/PS/182</u>	<u>Foam memory for changing humidity</u>
<u>INF GR/PS/183</u>	<u>OICA position on bonnet leading edge 165 mm exemption zone</u>
<u>INF GR/PS/184</u>	<u>Final draft gtr (without preamble)</u>
<u>INF GR/PS/185</u>	<u>Mr Saul letter dated on 3/1/2006</u>
<u>INF GR/PS/186</u>	<u>NHTSA revision of preamble PS/160</u>
<u>INF GR/PS/187</u>	<u>EEVC WG17 report</u>
<u>INF GR/PS/188</u>	<u>Draft meeting minutes of the 10th meeting</u>
<u>INF GR/PS/189</u>	<u>Attendance list 10th meeting</u>

B. TEXT OF THE REGULATION

1. PURPOSE AND SCOPE

1.1. The purpose of this global technical regulation is to bring about an improvement in the construction of certain parts of the front of vehicles which have been identified as causing injury when in collision with a pedestrian or other vulnerable road user.

The vehicles to be tested under the regulation are representative of the majority of vehicles in circulation in the urban environment, where there is a greater potential for collision with pedestrians and other vulnerable road users, and include passenger cars, vans and light trucks.

2. APPLICATION

This global technical regulation (gtr) shall apply to the frontal surfaces of power driven vehicles of category 1-1 [with a gross vehicle mass exceeding 0.5 tonnes but not exceeding 2.5 tonnes], and of category 2 [with a gross vehicle mass exceeding 0.5 tonnes but not exceeding 2.5 tonnes], which forward of the A-pillars have the same general structure and shape as a pre-existing category 1-1 vehicle. All definitions of Special Resolution No. 1 (S.R.1) shall apply as necessary.

3. DEFINITIONS

When performing measurements as described in this Part, the vehicle should be positioned in its normal ride attitude.

If the vehicle is fitted with a badge, mascot or other structure, which would bend back or retract under an applied load of maximum 100 N, then this load shall be applied before and/or while these measurements are taken.

Any vehicle component which could change shape or position, other than suspension components or active devices to protect pedestrians, shall be set to their stowed position.

For the purposes of this regulation:

3.1. "Adult headform test area" is an area on the outer surfaces of the front structure. The area is bounded, in the front, by a wrap around distance of 1,700 mm and, at the rear, by the rear reference line for adult headform and, at each side, by the side reference line.

3.2. "A-pillar" means the foremost and outermost roof support extending from the chassis to the roof of the vehicle.

3.3. "Bonnet leading edge" means the edge of the front upper outer structure of the vehicle, including the bonnet and wings, the upper and side members of the headlight surrounds and any other attachments. The reference line identifying the position of the bonnet leading edge is defined by its height above the ground reference plane and by the horizontal distance separating it from the bumper (bumper lead).

3.4. "Bonnet leading edge height" means, at any point on the bonnet leading edge, the vertical distance between the ground reference plane and the bonnet leading edge reference line at that point.

3.5. "Bonnet leading edge reference line" means the geometric trace of the points of contact between a straight edge 1,000 mm long and the front surface of the bonnet, when the straight edge, held parallel to the vertical longitudinal plane of the car and inclined rearwards by 50° from the vertical and with the lower end 600 mm above the ground, is traversed across and in contact with the bonnet leading edge (see Figure 1).

For vehicles having the bonnet top surface inclined at 50°, so that the straight edge makes a continuous contact or multiple contacts rather than a point contact, determine the reference line with the straight edge inclined rearwards at an angle of 40° from the vertical.

For vehicles of such shape that the bottom end of the straight edge makes first contact with the vehicle then that contact is taken to be the bonnet leading edge reference line, at that lateral position.

For vehicles of such shape that the top end of the straight edge makes first contact with the vehicle then the geometric trace of 1,000 mm wrap around distance, will be used as bonnet leading edge reference line at that lateral position.

The top edge of the bumper shall also be regarded as the bonnet leading edge if it is contacted by the straight edge during this procedure.

3.6. "Bonnet rear reference line" means the geometric trace of the most rearward points of contact between a 165 mm diameter sphere and the front structure of the vehicle when the sphere is traversed across the front structure of the vehicle while maintaining contact with the windscreen (see Figure 2).

Where the bonnet rear reference line and the side reference line do not intersect, the bonnet rear reference line should be extended and/or modified using a semi-circular template, of radius 100 mm. The template should be made of a thin flexible sheet material that easily bends to a single curvature in any direction. The template should, preferably, resist double or complex curvature where this could result in wrinkling. The recommended material is a foam backed thin plastic sheet to allow the template to "grip" the surface of the vehicle. The template should be marked up with four points "A" through "D", as shown in Figure 3, while the template is on a flat surface.

The template should be placed on the vehicle with Corners "A" and "B" coincident with the side reference line. Ensuring these two corners remain coincident with the side reference line, the template should be slid progressively rearwards until the arc of the template makes first contact with the bonnet rear reference line. Throughout the process, the template should be curved to follow, as closely as possible, the outer contour of the vehicle's bonnet top, without wrinkling or folding of the template. If the contact between the template and bonnet rear reference line is tangential and the point of tangency lies

outside the arc scribed by points "C" and "D", then the bonnet rear reference line is extended and/or modified to follow the circumferential arc of the template to meet the bonnet side reference line, as shown in Figure 4.

If the template cannot make simultaneous contact with the bonnet side reference line at points "A" and "B" and tangentially with the bonnet rear reference line, or the point at which the bonnet rear reference line and template touch lies within the arc scribed by points "C" and "D", then additional templates should be used where the radii are increased progressively in increments of 20 mm, until all the above criteria are met.

- 3.7. "Bonnet top" is the area which is bounded by (a), (b) and (c) as follows:
- (a) the bonnet leading edge reference line;
 - (b) the bonnet rear reference line;
 - (c) the side reference lines.
- 3.8. "Bumper" means the front, lower, outer structure of a vehicle. It includes all structures that are intended to give protection to a vehicle when involved in a low speed frontal collision and also any attachments to this structure. The reference height and lateral limits of the bumper are identified by the bumper reference lines and the corners.
- 3.9. "Bumper lead" means for any longitudinal section of a vehicle, the horizontal distance in the vehicle longitudinal plane between the upper bumper reference line and the bonnet leading edge reference line.
- 3.10. "Bumper test area" means the frontal surface of the bumper limited by two longitudinal vertical planes intersecting the corners of the bumper and moved 66 mm parallel and inboard of the corners of the bumper.
- 3.11. "Centre of the knee" of the lower legform impactor is defined as the point about which the knee effectively bends.
- 3.12. "Child headform test area" is an area on the outer surfaces of the front structure. The area is bounded, in the front, by the front reference line for child headform, and, at the rear, by the WAD1700 line, and by the side reference lines.
- 3.13. "Corner of bumper" means the vehicle's point of contact with a vertical plane which makes an angle of 60° with the vertical longitudinal plane of the car and is tangential to the outer surface of the bumper (see Figure 5).
- 3.14. "Femur" of the lower legform impactor is defined as all components or parts of components (including flesh, skin covering, damper, instrumentation and brackets, pulleys, etc. attached to the impactor for the purpose of launching it) above the level of the centre of the knee.
- 3.15. "Front reference line for child headform" means the geometric trace as described on the vehicle front structure using a WAD1000 line. In the case of vehicles where the wrap around distance to the bonnet leading edge reference line, is more than 1,000 mm at any

point, then the bonnet leading edge reference line will be used as the front reference line for child headform at that point.

3.16. "Front structure" means all outer structures of the vehicle except the windscreen, the windscreen header, the A-pillars and structures rearward of these. It therefore includes, but is not limited to, the bumper, the bonnet, wings, scuttle, wiper spindles and lower windscreen frame.

3.17. "Ground reference plane" means a horizontal plane, either real or imaginary, that passes through the lowest points of contact for all tyres of a vehicle while the vehicle is in its normal ride attitude. If the vehicle is resting on the ground, then the ground level and the ground reference plane are one and the same. If the vehicle is raised off the ground such as to allow extra clearance below the bumper, then the ground reference plane is above ground level.

3.18. "Head Injury Criterion (HIC)" means the calculated result of accelerometer time histories using the following formula:

$$\text{HIC} = \left[\frac{1}{t_2 - t_1} \int_{t_1}^{t_2} a \, dt \right]^{2.5} (t_2 - t_1)$$

Where:

a is the resultant acceleration measured in units of gravity "g" (1 g = 9.81 m/s²);

t₁ and t₂ are the two time instants (expressed in seconds) during the impact, defining an interval between the beginning and the end of the recording period for which the value of HIC is a maximum (t₂ - t₁ ≤ 15 ms)

3.19. "Impact point" means the point on the vehicle where initial contact by the test impactor occurs. The proximity of this point to the target point is dependent upon both the angle of travel by the test impactor and the contour of the vehicle surface (see point B in Figure 6).

3.20. "Lower bumper height" means the vertical distance between the ground reference plane and the lower bumper reference line, with the vehicle positioned in its normal ride attitude.

3.21. "Lower bumper reference line" means the lower limit to significant points of pedestrian contact with the bumper. It is defined as the geometric trace of the lowermost points of contact between a straight edge 700 mm long and the bumper, when the straight edge, held parallel to the vertical longitudinal plane of the car and inclined forwards by 25° from the vertical, is traversed across the front of the car, while maintaining contact with the ground and with the surface of the bumper (see Figure 7).

3.22. "Normal ride attitude" means the vehicle positioned on a flat horizontal surface with its mass in running order (as defined in Annex 3, paragraph 3 of Special Resolution No. 1), with the tyres inflated to manufacturer recommended pressures, the front wheels in the

straight-ahead position and with a passenger mass (as defined in Annex 3, paragraph 6.2. of Special Resolution No. 1) placed on the front passenger seat. The front seats are placed at the nominal mid-track position. The suspension shall be set in normal running condition as specified by the manufacturer for a speed of 40 km/h.

- 3.23. "Rear reference line for adult headform" means a geometric trace as described on the front structure of the vehicle using a WAD2100 line.
- 3.24. "Side reference line" means the geometric trace of the highest points of contact between a straight edge 700 mm long and the sides of the vehicle, when the straight edge, held parallel to the transverse vertical plane of the vehicle and inclined inwards by 45°, is traversed down, and maintains contact with, the sides of the front structure (see Figure 8).
- 3.25. "Target point" means the intersection of the projection of the headform longitudinal axis with the front surface of the vehicle (see point A in Figure 6.).
- 3.26. "Tibia" of the lower legform impactor is defined as all components or parts of components (including flesh, skin covering, instrumentation and brackets, pulleys, etc. attached to the impactor for the purpose of launching it) below the level of the centre of the knee. Note that the tibia as defined includes allowances for the mass, etc., of the foot.
- 3.27. "Upper bumper reference line" means the upper limit to significant points of pedestrian contact with the bumper. For vehicles with an identifiable bumper structure it is defined as the geometric trace of the uppermost points of contact between a straight edge and the bumper, when the straight edge, held parallel to the vertical longitudinal plane of the car and inclined rearwards by 20° to the vertical, is traversed across the front of the car, while maintaining contact with the surface of the bumper (see Figure 9).

For vehicles with no identifiable bumper structure it is defined as the geometric trace of the uppermost points of contact between a straight edge 700 mm long and the bumper area, when the straight edge, held parallel to the vertical longitudinal plane of the car and inclined rearwards by 20° from the vertical is traversed across the front of the car, while maintaining contact with the ground and with the surface of the bumper area (see Figure 9).

- 3.28. "Wrap Around Distance (WAD)" means the geometric trace described on the outer surface of the vehicle front structure by one end of a flexible tape, when it is held in a vertical longitudinal plane of the vehicle and traversed across the front structure. The tape is held taut throughout the operation with one end held at ground reference level, vertically below the front face of the bumper and the other end held in contact with the front structure (see Figure 10). The vehicle is positioned in the normal ride attitude.

This procedure shall be followed, using alternative tapes of appropriate lengths, to describe wrap around distances of 1,000 mm (WAD1000), of 1,700 mm (WAD1700) and of 2,100 mm (WAD2100).

3.29. "Windscreen" means the frontal glazing of the vehicle situated between the A-pillars.

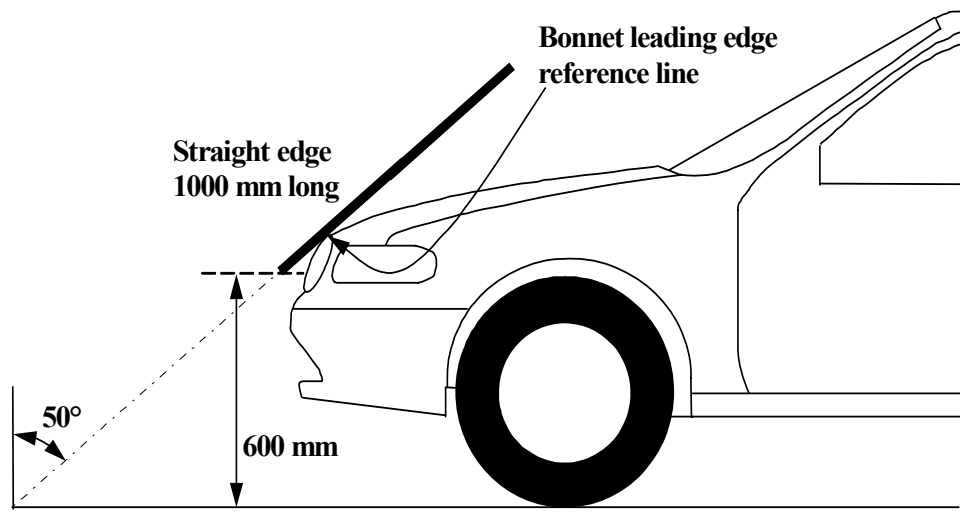

Figure 1: Bonnet leading edge reference line. (see paragraph 3.5.)

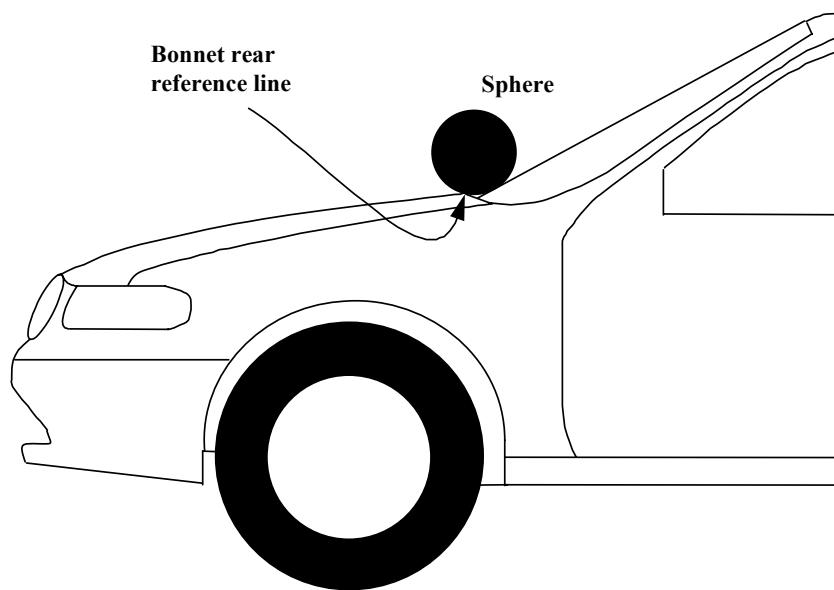

Figure 2: Bonnet rear reference line. (see paragraph 3.6.)

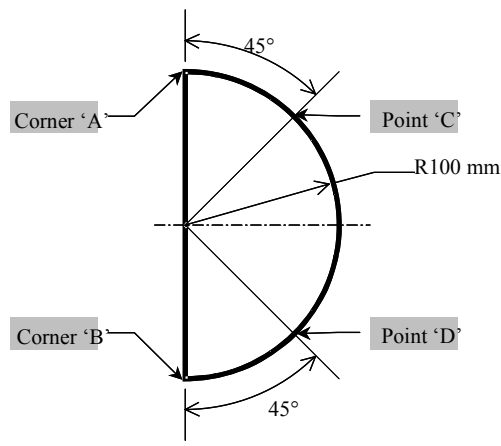

Figure 3: Template. (see paragraph 3.6.)

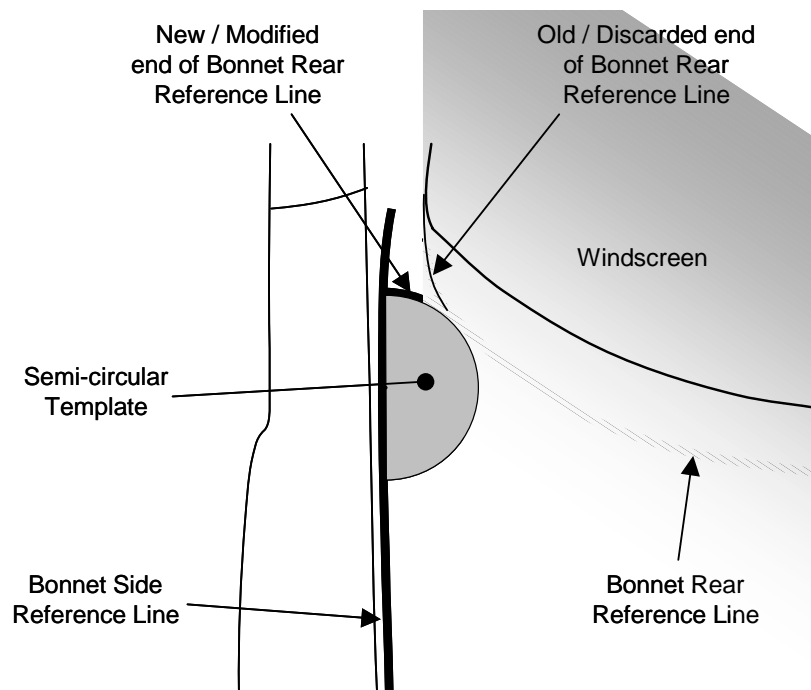

Figure 4: Marking of intersection between bonnet rear and side reference lines (see paragraph 3.6.)

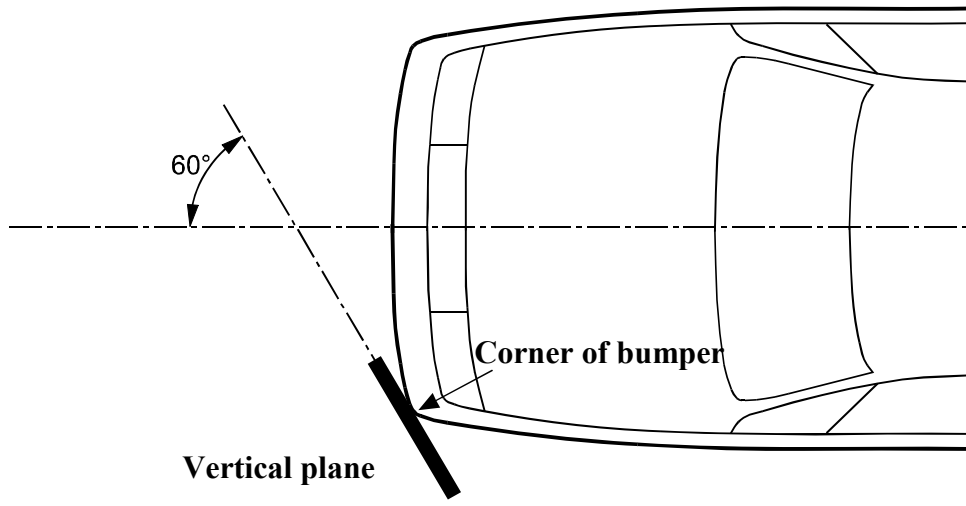

Figure 5: Corner of bumper (see paragraph 3.13.)

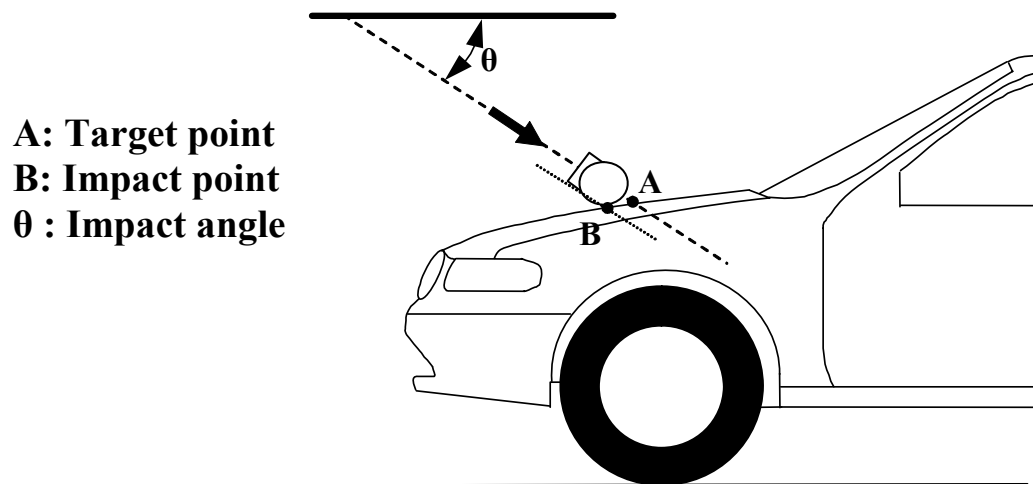

Figure 6: Impact and target point (see paragraphs 3.19. and 3.25.)

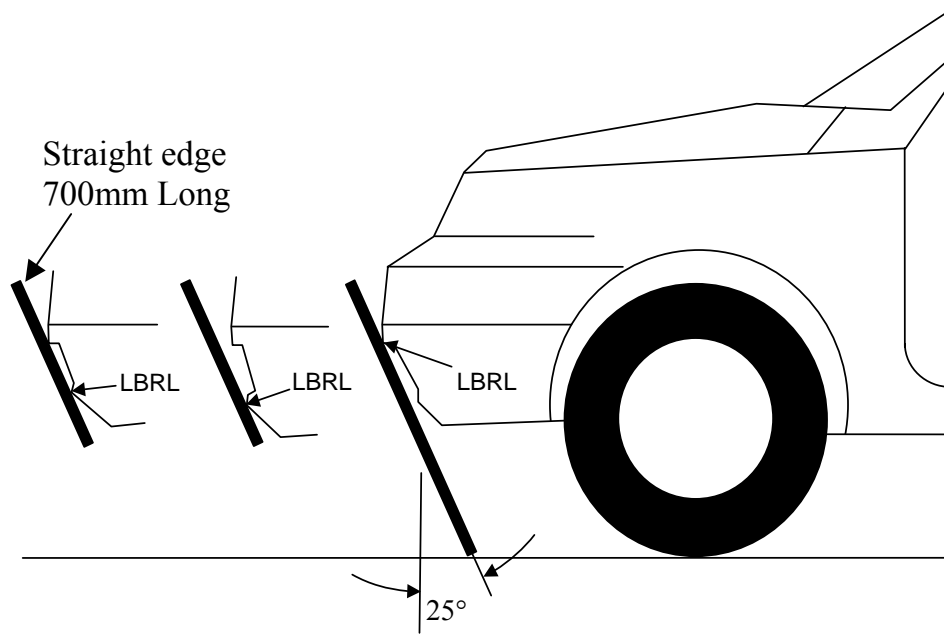

Figure 7: Lower bumper reference line, LBRL (see paragraph 3.21.)

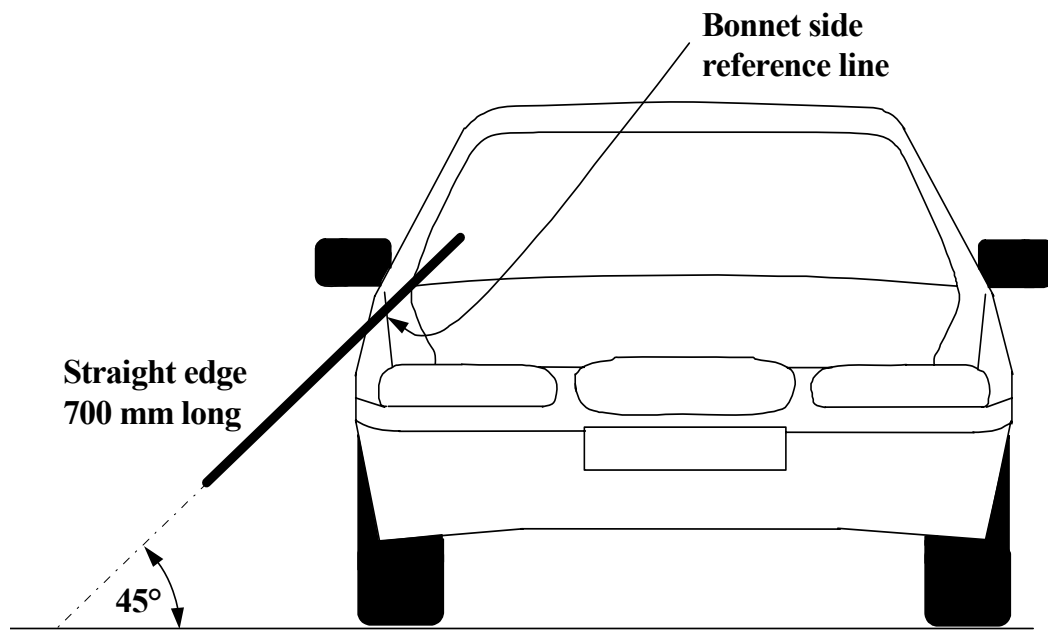

Figure 8: Side reference line (see paragraph 3.24.)

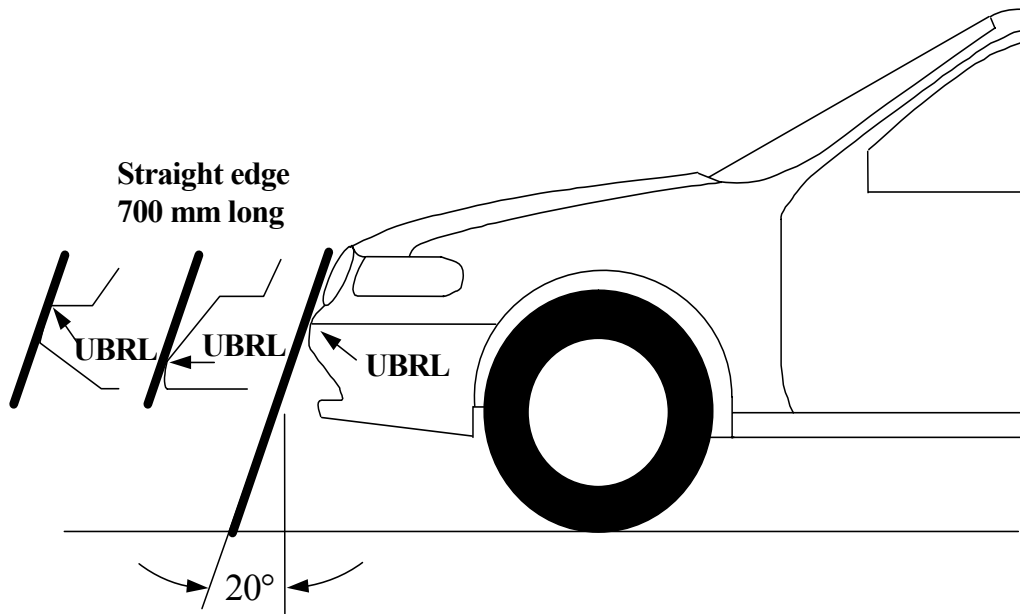

Figure 9: Upper bumper reference line, UBRL (see paragraph 3.27.)

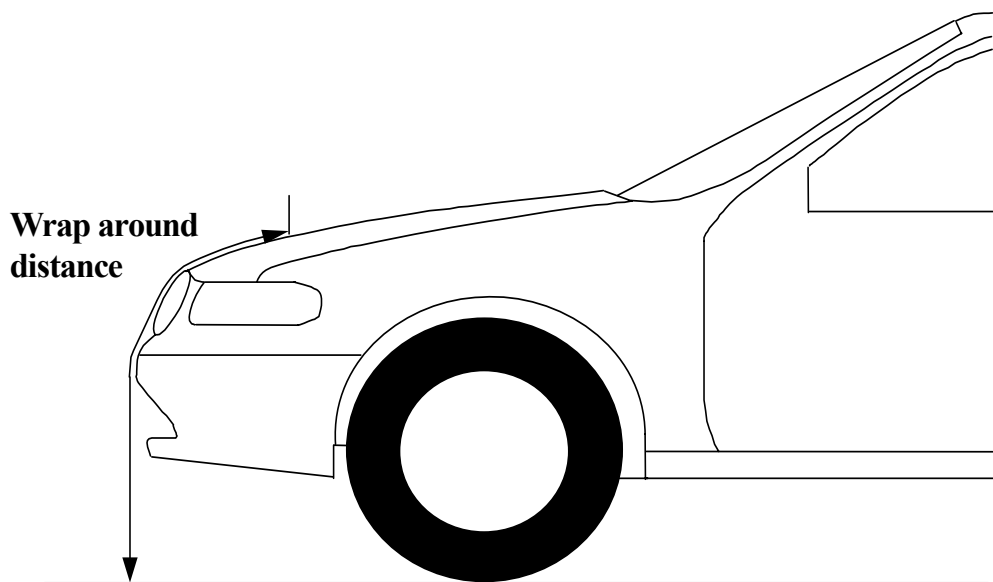

Figure 10: Wrap around distance measurement (see paragraph 3.28.)

4. GENERAL REQUIREMENTS

This global technical regulation specifies the following tests to verify compliance of vehicles.

4.1. Legform test to bumper:

For vehicles with a lower bumper height of less than 425 mm the requirements of paragraph 4.1.1. shall be applied.

For vehicles with a lower bumper height which is both greater than, or equal to 425 mm and less than 500 mm the requirements of either paragraph 4.1.1. or 4.1.2., at the choice of the manufacturer, shall be applied.

For vehicles with a lower bumper height of greater than, or equal to, 500 mm the requirements of paragraph 4.1.2. shall be applied.

4.1.1. Lower legform to bumper:

To verify compliance with the performance requirements as specified in paragraph 5.1.1., both the test impactor specified in paragraph 6.3.1.1. and the test procedures specified in paragraph 7.1.1. shall be used.

4.1.2. Upper legform to bumper:

To verify compliance with the performance requirements as specified in paragraph 5.1.2., both the test impactor specified in paragraph 6.3.1.2. and the test procedures specified in paragraph 7.1.2. shall be used.

4.2. Child headform impact:

To verify compliance with the performance requirements as specified in paragraph 5.2.1., both the test impactor specified in paragraph 6.3.2.1. and the test procedures specified in paragraphs 7.2. and 7.3. shall be used.

4.3. Adult headform impact:

To verify compliance with the performance requirements as specified in paragraph 5.2.2., both the test impactor specified in paragraph 6.3.2.2. and the test procedures specified in paragraphs 7.2. and 7.4. shall be used.

5. PERFORMANCE REQUIREMENTS

5.1. Legform to bumper:

5.1.1. When tested in accordance with paragraph 7.1.1. (lower legform to bumper), the maximum dynamic knee bending angle shall not exceed 19°, the maximum dynamic knee shearing displacement shall not exceed 6.0 mm, and the acceleration

measured at the upper end of the tibia shall not exceed 170 g. In addition the manufacturer may nominate bumper test widths up to a maximum of 264 mm in total where the acceleration measured at the upper end of the tibia shall not exceed 250 g.

5.1.2. When tested in accordance with paragraph 7.1.2. (upper legform to bumper), the instantaneous sum of the impact forces with respect to time shall not exceed 7.5 kN and the bending moment on the test impactor shall not exceed 510 Nm.

5.2. Headform tests

5.2.1. Child headform to front structure:

When tested in accordance with paragraphs 7.2. and 7.3. the HIC shall comply with paragraph 5.2.3.

5.2.2. Adult headform to the front structure:

When tested in accordance with paragraph 7.2. and 7.4. the HIC shall comply with paragraph 5.2.3.

5.2.3. The HIC recorded shall not exceed 1,000 over a minimum of one half of the child headform test area and 1,000 over two third of the combined child and adult headform test areas. The HIC for the remaining areas shall not exceed 1,700 for both headforms.

In case there is only a child headform test area, the HIC recorded shall not exceed 1,000 over two third of the test area. For the remaining area the HIC shall not exceed 1,700.

5.2.4. Splitting of headform test zone

5.2.4.1. The manufacturer shall identify the zones of the bonnet top where the HIC must not exceed 1,000 (HIC1000 Zone) or 1,700 (HIC1700 Zone) (see Figure 11).

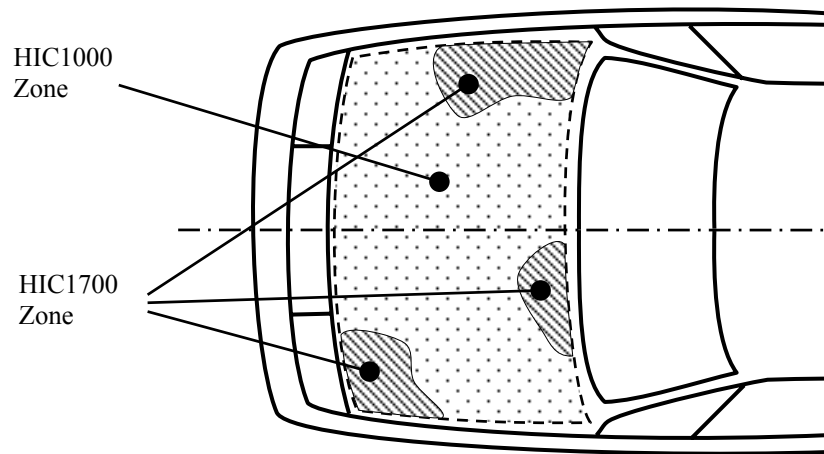

Figure 11: Example of marking of HIC1000 zone and HIC1700 zone

5.2.4.2. Marking of the "bonnet top" impact area as well as "HIC1000 Zone" and "HIC1700 Zone" will be based on a drawing supplied by the manufacturer, when viewed from a horizontal plane above the vehicle that is parallel to the vehicle horizontal zero plane. A sufficient number of x and y co-ordinates shall be supplied by the manufacturer to mark up the areas on the actual vehicle while considering the vehicle outer contour in the z direction.

5.2.4.3. The areas of "HIC1000 Zone" and "HIC1700 Zone" may consist of several parts, with the number of these parts not being limited.

5.2.4.4. The calculation of the surface of the impact area as well as the surface areas of "HIC1000 Zone" and "HIC1700 Zone" shall be done on the basis of a projected bonnet when viewed from a horizontal plane parallel to the horizontal zero plane above the vehicle, on the basis of the drawing data supplied by the manufacturer.

6. TEST SPECIFICATIONS

6.1. General test conditions

6.1.1. Temperature and humidity

At the time of testing, the test facility and the vehicle or sub-system shall have a relative humidity of 40 per cent \pm 30 per cent and stabilized temperature of 20 ± 4 °C.

6.1.2. Impact test site

The test site shall consist of a flat, smooth and hard surface with a slope not exceeding 1 per cent.

6.2. Preparation of the vehicle

6.2.1. Either a complete vehicle, or a cut-body, adjusted to the following conditions shall be used for the test.

6.2.1.1. The vehicle shall be in its normal ride attitude, and shall be either securely mounted on raised supports or at rest on a flat horizontal surface with the parking brake applied.

6.2.1.2. The cut-body shall include, in the test, all parts of the vehicle front structure, all under-bonnet components and all components behind the windscreen that may be involved in a frontal impact with a vulnerable road user in order to demonstrate the performance and interactions of all the contributory vehicle components. The cut-body shall be securely mounted in the normal vehicle ride attitude.

6.2.2. All devices designed to protect vulnerable road users when impacted by the vehicle shall be correctly activated before and/or be active during the relevant test. It shall be the responsibility of the manufacturer to show that any devices will act as intended in a pedestrian impact.

6.2.3. For vehicle components which could change shape or position, other than active devices to protect pedestrians, and which have more than one fixed shape or position shall require the vehicle to comply with the components in each fixed shape or position.

6.3. Test impactor specifications

6.3.1. Legform impactors:

6.3.1.1. Lower legform impactor:

The lower legform impactor shall consist of two foam covered rigid segments, representing femur (upper leg) and tibia (lower leg), joined by a deformable, simulated knee joint. The overall length of the impactor shall be 926 ± 5 mm, having a required test mass of 13.4 ± 0.2 kg (see Figure 12).

The above dimensions do not include brackets, pulleys, etc. attached to the impactor for the purpose of launching it.

6.3.1.1.1. The diameter of the femur and tibia shall be 70 ± 1 mm and both shall be covered by foam flesh and skin. The foam flesh shall be 25 mm thick Confor™ foam type CF-45 or equivalent. The skin shall be made of neoprene foam, faced with 0.5 mm thick nylon cloth both sides, with an overall thickness of 6 mm.

6.3.1.1.2. The knee joint shall be fitted with deformable knee elements from the same batch as those used in the certification tests.

- 6.3.1.1.3. The total masses of the femur and tibia shall be 8.6 ± 0.1 kg and 4.8 ± 0.1 kg respectively, and the total mass of the impactor shall be 13.4 ± 0.2 kg. The centre of gravity of the femur and tibia shall be 217 ± 10 mm and 233 ± 10 mm from the centre of the knee respectively. The moment of inertia of the femur and tibia, about a horizontal axis through the respective centre of gravity and perpendicular to the direction of impact, shall be 0.127 ± 0.010 kgm² and 0.120 ± 0.010 kgm² respectively.
- 6.3.1.1.4. For each test the impactor shall be fitted with new foam flesh cut from one of up to four consecutive sheets of Confor™ foam type CF-45 flesh material or equivalent, produced from the same batch of manufacture (cut from one block or ‘bun’ of foam), provided that foam from one of these sheets was used in the dynamic certification test and the individual mass of these sheets are within ± 2 per cent of the mass of the sheet used in the certification test.
- 6.3.1.1.5. The test impactor or at least the foam flesh shall be stored during a period of at least four hours in a controlled storage area with a stabilized humidity of 35 per cent ± 15 per cent and a stabilized temperature of $20 \pm 4^{\circ}\text{C}$ prior to impactor removal for calibration. After removal from the storage the impactor shall not be subjected to conditions other than those pertaining in the test area.
- 6.3.1.1.6. Lower legform instrumentation
- 6.3.1.1.6.1. A uniaxial accelerometer shall be mounted on the non-impacted side of the tibia, 66 ± 5 mm below the knee joint centre, with its sensitive axis in the direction of impact.
- 6.3.1.1.6.2. A damper shall be fitted to the shear displacement system and may be mounted at any point on the rear face of the impactor or internally. The damper properties shall be such that the impactor meets both the static and dynamic shear displacement requirements and prevents excessive vibrations of the shear displacement system.
- 6.3.1.1.6.3. Transducers shall be fitted to measure knee bending angle and knee shearing displacement.
- 6.3.1.1.6.4. The instrumentation response value CFC(Channel Frequency Class), as defined in ISO 6487:2002, shall be 180 for all transducers. The CAC(Channel Amplitude Class) response values, as defined in ISO 6487:2002, shall be 50° for the knee bending angle, 10 mm for the shearing displacement and 500 g for the acceleration. This does not require that the impactor itself be able to physically bend and shear to these angles and displacements.
- 6.3.1.1.7. Lower legform certification
- 6.3.1.1.7.1. The lower legform impactor shall meet the performance requirements specified in section 8.

6.3.1.1.7.2. The certified impactor may be used for a maximum of 20 impacts before re-certification. With each test new plastically deformable knee elements shall be used. The impactor shall also be re-certified if more than one year has elapsed since the previous certification, if any impactor transducer output, in any impact, has exceeded the specified CAC or has reached the mechanical limits of the leg impactor deformation capability.

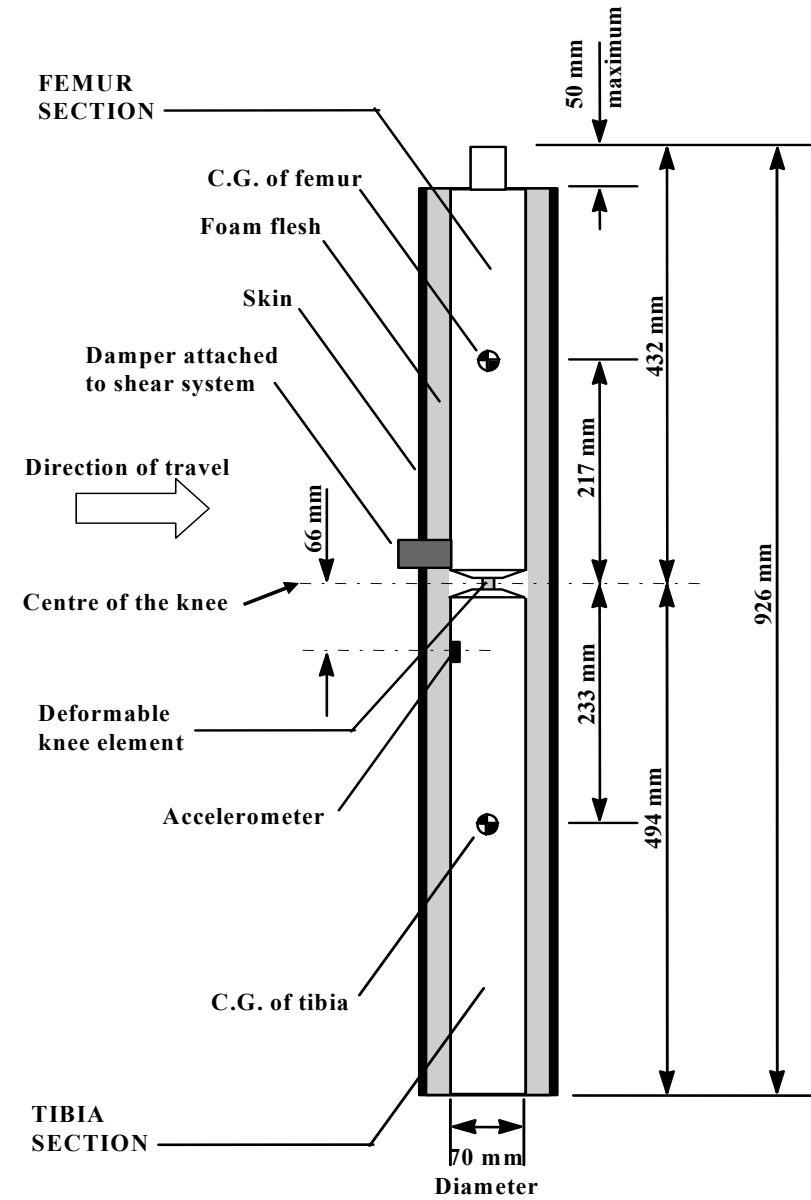

Figure 12: Lower legform impactor. (see paragraph 6.3.1.1.)

6.3.1.2. Upper legform impactor:

The upper legform impactor shall be rigid, foam covered at the impact side, and 350 ± 5 mm long (see Figure 13).

6.3.1.2.1. The total mass of the upper legform impactor including those propulsion and guidance components which are effectively part of the impactor during the impact shall be 9.5 ± 0.1 kg.

6.3.1.2.2. The total mass of the front member and other components in front of the load transducer assemblies, together with those parts of the load transducer assemblies in front of the active elements, but excluding the foam and skin, shall be 1.95 ± 0.05 kg.

6.3.1.2.3. The upper legform impactor for the bumper test shall be mounted to the propulsion system by a torque-limiting joint and be insensitive to off-axis loading. The impactor shall move only in the specified direction of impact when in contact with the vehicle and shall be prevented from motion in other directions including rotation about any axis.

6.3.1.2.4. The torque limiting joint shall be set so that the longitudinal axis of the front member is vertical at the time of impact with a tolerance of $\pm 2^\circ$, with the joint friction torque set to 675 ± 25 Nm.

6.3.1.2.5. The centre of gravity of those parts of the impactor which are effectively forward of the torque limiting joint, including any weights fitted, shall lie on the longitudinal centre line of the impactor, with a tolerance of ± 10 mm.

6.3.1.2.6. The length between the load transducer centre lines shall be 310 ± 1 mm and the front member diameter shall be 50 ± 1 mm.

6.3.1.2.7. For each test the foam flesh shall be two new sheets of 25 mm thick ConforTM foam type CF-45 or equivalent, which shall be cut from the sheet of material used for the dynamic certification test. The skin shall be a 1.5 mm thick fibre reinforced rubber sheet. The mass of the foam and rubber skin together shall be 0.6 ± 0.1 kg (this excludes any reinforcement, mountings, etc. which are used to attach the rear edges of the rubber skin to the rear member). The foam and rubber skin shall be folded back towards the rear, with the rubber skin attached via spacers to the rear member so that the sides of the rubber skin are held parallel. The foam shall be of such a size and shape that an adequate gap is maintained between the foam and components behind the front member, to avoid significant load paths between the foam and these components.

6.3.1.2.8. The test impactor or at least the foam flesh shall be stored during a period of at least four hours in a controlled storage area with a stabilized humidity of 35 per cent \pm 15 per cent and a stabilized temperature of $20 \pm 4^\circ\text{C}$ prior to impactor removal for calibration. After removal from the storage the impactor shall not be subjected to conditions other than those pertaining in the test area.

6.3.1.2.9. Upper legform instrumentation

6.3.1.2.9.1. The front member shall be strain gauged to measure bending moments in three positions, as shown in Figure 13, each using a separate channel. The strain gauges are located on the impactor on the back of the front member. The two outer strain gauges are located 50 ± 1 mm from the impactor's symmetrical axis. The middle strain gauge is located on the symmetrical axis with a ± 1 mm tolerance.

6.3.1.2.9.2. Two load transducers shall be fitted to measure individually the forces applied at either end of the upper legform impactor, plus strain gauges measuring bending moments at the centre of the upper legform impactor and at positions 50 mm either side of the centre line, (see Figure 13).

6.3.1.2.9.3. The instrumentation response value CFC, as defined in ISO 6487:2002, shall be 180 for all transducers. The CAC response values, as defined in ISO 6487:2002, shall be 10 kN for the force transducers and 1000 Nm for the bending moment measurements.

6.3.1.2.10. Upper legform certification

6.3.1.2.10.1. The upper legform impactor shall meet the performance requirements specified in section 8.

6.3.1.2.10.2. The certified impactor may be used for a maximum of 20 impacts before re-certification (this limit does not apply to propulsion or guidance components). The impactor shall also be re-certified if more than one year has elapsed since the previous certification or if any impactor transducer output, in any impact, has exceeded the specified CAC.

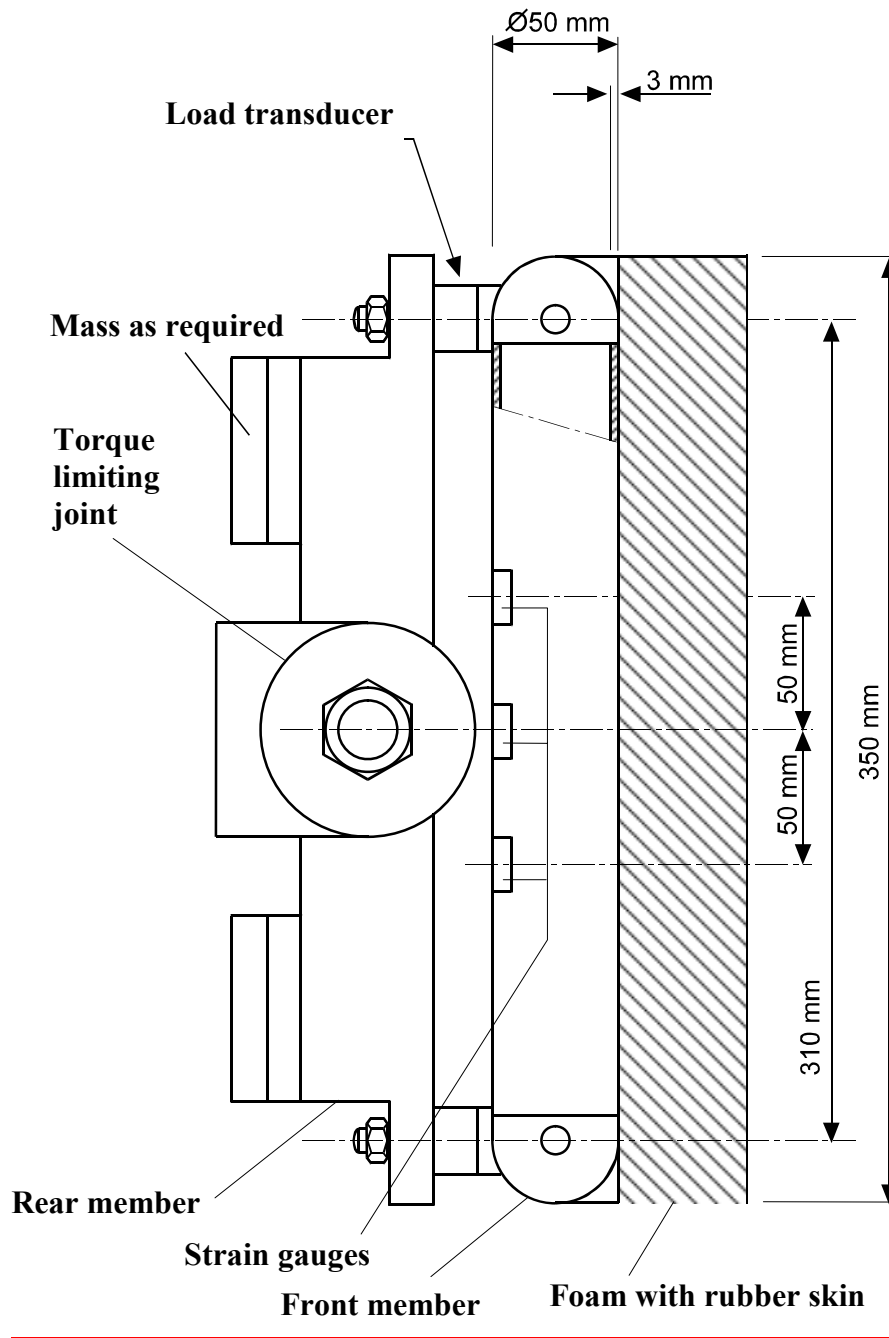

Figure 13: Upper legform impactor (see paragraph 6.3.1.2.)

6.3.2. Child and adult headform impactors

6.3.2.1. Child headform impactor (see Figure 14)

The child headform impactor shall be made of aluminium, be of homogenous construction and be of spherical shape. The overall diameter shall be 165 ± 1 mm. The mass shall be 3.5 ± 0.07 kg. The moment of inertia about an axis through the centre of gravity and perpendicular to the direction of impact shall be within the range of 0.008 to 0.012 kgm^2 . The centre of gravity of the headform impactor

including instrumentation shall be located in the geometric centre of the sphere with a tolerance of ± 2 mm.

The sphere shall be covered with a 14 ± 0.5 mm thick synthetic skin, which shall cover at least half of the sphere.

6.3.2.1.1. Child headform instrumentation

A recess in the sphere shall allow for mounting one triaxial or three uniaxial accelerometers within ± 10 mm seismic mass location tolerance from the centre of the sphere for the measurement axis, and ± 1 mm seismic mass location tolerance from the centre of the sphere for the perpendicular direction to the measurement axis.

If three uniaxial accelerometers are used, one of the accelerometers shall have its sensitive axis perpendicular to the mounting face A (see Figure 14) and its seismic mass shall be positioned within a cylindrical tolerance field of 1 mm radius and 20 mm length. The centre line of the tolerance field shall run perpendicular to the mounting face and its mid-point shall coincide with the centre of the sphere of the headform impactor.

The remaining accelerometers shall have their sensitive axes perpendicular to each other and parallel to the mounting face A and their seismic mass shall be positioned within a spherical tolerance field of 10 mm radius. The centre of the tolerance field shall coincide with the centre of the sphere of the headform impactor.

The instrumentation response value CFC, as defined in ISO 6487: 2002, shall be 1,000. The CAC response value, as defined in ISO 6487: 2002, shall be 500 g for the acceleration.

6.3.2.1.2. First natural frequency

The first natural frequency of the headform impactor shall be over 5,000 Hz.

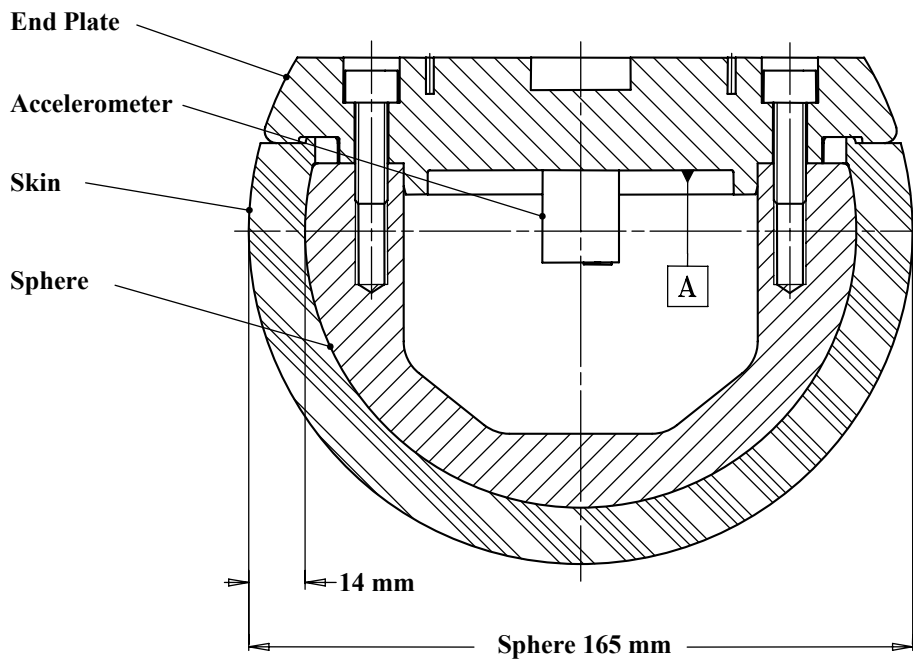

Figure 14: Child headform impactor (see paragraph 6.3.2.1.)

6.3.2.2. Adult headform impactor (see Figure 15)

The adult headform impactor shall be made of aluminium, be of homogenous construction and be of spherical shape. The overall diameter is 165 ± 1 mm as shown in Figure 15. The mass shall be 4.5 ± 0.1 kg. The moment of inertia about an axis through the centre of gravity and perpendicular to the direction of impact shall be within the range of 0.010 to 0.013 kgm^2 . The centre of gravity of the headform impactor including instrumentation shall be located in the geometric centre of the sphere with a tolerance of ± 5 mm.

The sphere shall be covered with a 14 ± 0.5 mm thick synthetic skin, which shall cover at least half of the sphere.

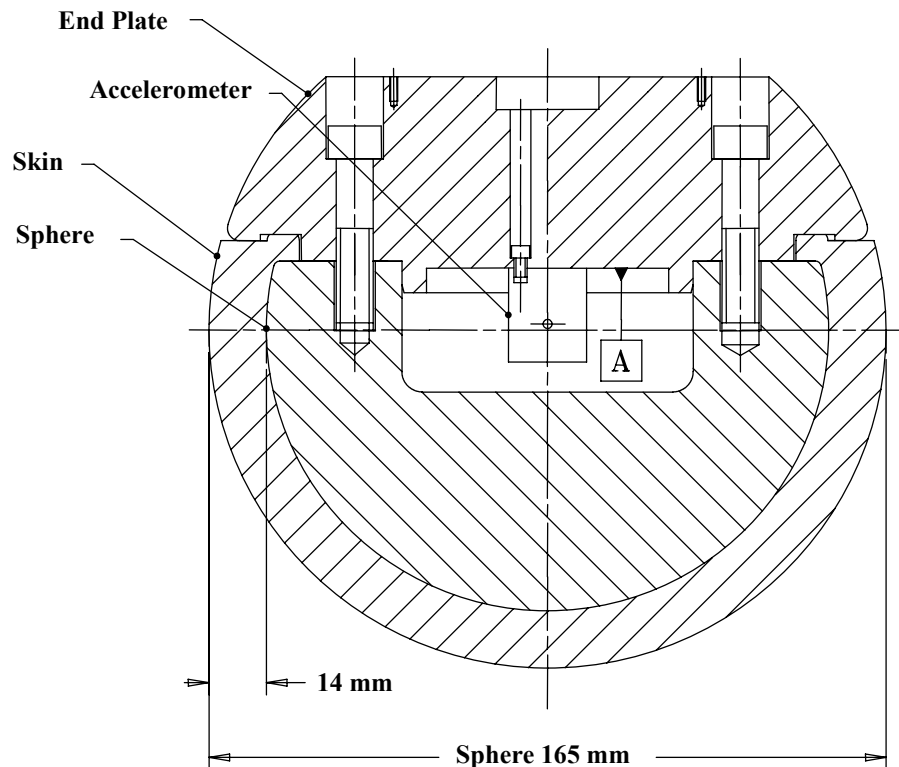

Figure 15: Adult headform impactor (see paragraph 6.3.2.2)

6.3.2.2.1. Adult headform instrumentation

A recess in the sphere shall allow for mounting one triaxial or three uniaxial accelerometers within ± 10 mm seismic mass location tolerance from the centre of the sphere for the measurement axis, and ± 1 mm seismic mass location tolerance from the centre of the sphere for the perpendicular direction to the measurement axis.

If three uniaxial accelerometers are used, one of the accelerometers shall have its sensitive axis perpendicular to the mounting face A (see Figure 15) and its seismic mass shall be positioned within a cylindrical tolerance field of 1 mm radius and 20 mm length. The centre line of the tolerance field shall run perpendicular to the mounting face and its mid-point shall coincide with the centre of the sphere of the headform impactor.

The remaining accelerometers shall have their sensitive axes perpendicular to each other and parallel to the mounting face A and their seismic mass shall be positioned within a spherical tolerance field of 10 mm radius. The centre of the tolerance field shall coincide with the centre of the sphere of the headform impactor.

The instrumentation response value CFC, as defined in ISO 6487: 2002, shall be 1,000. The CAC response value, as defined in ISO 6487: 2002, shall be 500 g for the acceleration.

6.3.2.2. First natural frequency

The first natural frequency of the headform impactor shall be over 5,000 Hz.

6.3.2.3. Rear face of the headform impactors

A rear flat face shall be provided on the outer surface of the headform impactors which is perpendicular to the direction of travel, and typically perpendicular to the axis of one of the accelerometers as well as being a flat plate capable of providing for access to the accelerometers and an attachment point for the propulsion system.

6.3.2.4. Certification of the headform impactors

The headform impactors shall meet the performance requirements specified in section 8. The certified impactors may be used for a maximum of 20 impacts before re-certification. The impactors shall be re-certified if more than one year has elapsed since the previous certification or if the transducer output, in any impact, has exceeded the specified CAC.

7. TEST PROCEDURES

7.1. Legform to bumper test procedures

7.1.1. Lower legform to bumper test procedure:

Each test shall be completed within two hours of when the impactor to be used is removed from the controlled storage area.

7.1.1.1. The selected target points shall be in the bumper test area.

7.1.1.2. The direction of the impact velocity vector shall be in the horizontal plane and parallel to the longitudinal vertical plane of the vehicle. The tolerance for the direction of the velocity vector in the horizontal plane and in the longitudinal plane shall be $\pm 2^\circ$ at the time of first contact. The axis of the impactor shall be perpendicular to the horizontal plane with a tolerance of $\pm 2^\circ$ in the lateral and longitudinal planes. The horizontal, longitudinal and lateral planes are orthogonal to each other (see Figure 16).

7.1.1.3. The bottom of the impactor shall be at 25 mm above ground reference plane at the time of first contact with the bumper (see Figure 17), with a ± 10 mm tolerance. When setting the height of the propulsion system, an allowance must be made for the influence of gravity during the period of free flight of the impactor.

7.1.1.3.1. The lower legform impactor for the bumper tests shall be in 'free flight' at the moment of impact. The impactor shall be released to free flight at such a distance from the vehicle that the test results are not influenced by contact of the impactor with the propulsion system during rebound of the impactor.

The impactor may be propelled by an air, spring, hydraulic gun, or by other means that shall meet impact conditions specified in paragraph 7.1.1.2 and 7.1.1.3.2.

7.1.1.3.2. At the time of first contact the impactor shall have the intended orientation about its vertical axis, for the correct operation of its knee joint, with a tolerance of $\pm 5^\circ$ (see Figure 16).

7.1.1.3.3. At the time of first contact the centre line of the impactor shall be within a ± 10 mm tolerance to the selected impact location.

7.1.1.3.4. During contact between the impactor and the vehicle, the impactor shall not contact the ground or any object which is not part of the vehicle.

7.1.1.4. The impact velocity of the impactor when striking the bumper shall be 11.1 ± 0.2 m/s. The effect of gravity shall be taken into account when the impact velocity is obtained from measurements taken before the time of first contact.

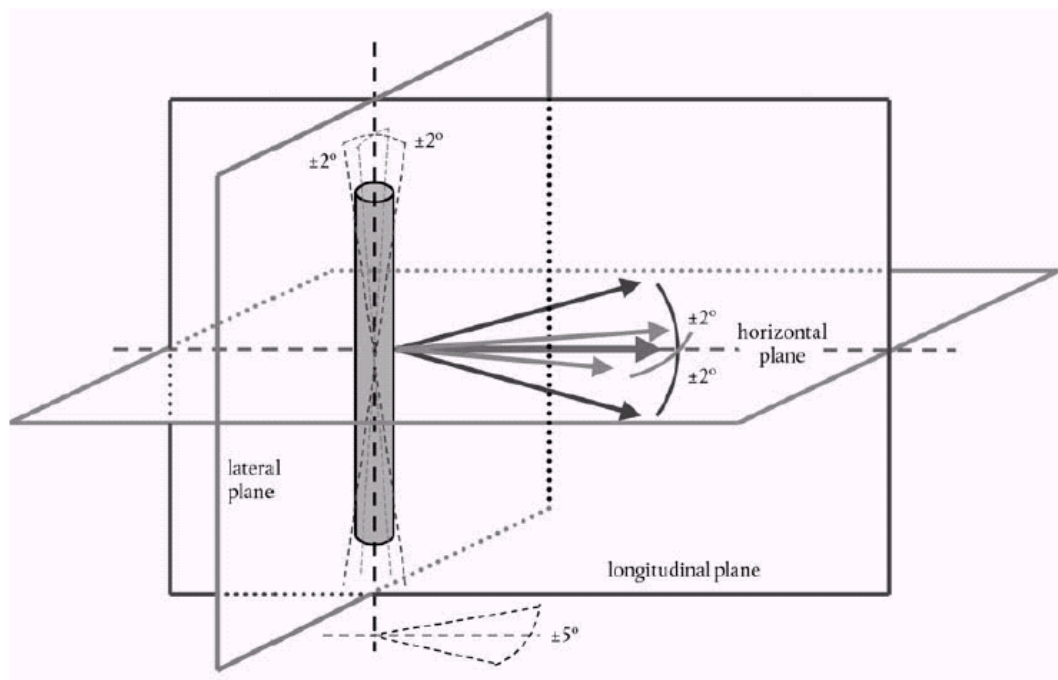

Figure 16: Tolerances of angles for the lower legform impactor at the time of the first impact (see paragraphs 7.1.1.2 and 7.1.1.3.2.)

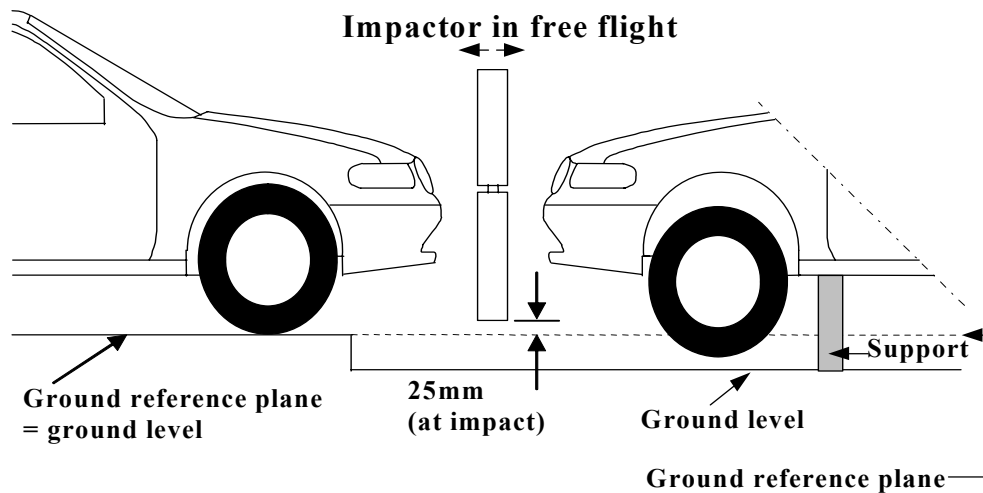

Figure 17: Lower legform to bumper tests for complete vehicle in normal ride attitude (left) and for cut-body mounted on supports (right) (see paragraph 7.1.1.3)

7.1.2. Upper legform to bumper test procedure:

Each test shall be completed within two hours of when the impactor to be used is removed from the controlled storage area.

7.1.2.1. The selected target points shall be in the bumper test area as defined in paragraph 3.10.

7.1.2.2. The direction of impact shall be parallel to the longitudinal axis of the vehicle, with the axis of the upper legform vertical at the time of first contact. The tolerance to this direction is $\pm 2^\circ$.

At the time of first contact the impactor horizontal centre line shall be vertically midway between the upper bumper reference line and the lower bumper reference line with a ± 10 mm tolerance and the impactor vertical centre line shall be positioned laterally with the selected impact location with a tolerance of ± 10 mm.

7.1.2.3. The impact velocity of the upper legform impactor when striking the bumper shall be 11.1 ± 0.2 m/s.

7.2. Headform test procedures

7.2.1. Propulsion of the headform impactors

The headform impactors shall be in "free flight" at the moment of impact, at the required impact velocity (as specified in paragraphs 7.3.4. and 7.4.4.) and the required direction of impact (as specified in paragraphs 7.3.5. and 7.4.5.).

The impactors shall be released to "free flight" at such a distance from the vehicle that the test results are not influenced by contact of the impactor with the propulsion system during rebound of the impactor.

7.2.2. Measurement of impact velocity

The velocity of the headform impactor shall be measured at some point during the free flight before impact, in accordance with the method specified in ISO 3784:1976. The accuracy of velocity measurement shall be ± 0.01 m/s. The measured velocity shall be adjusted considering all factors which may affect the impactor between the point of measurement and the point of impact, in order to determine the velocity of the impactor at the time of impact. The angle of the velocity vector at the time of impact shall be calculated or measured.

7.2.3. Recording

The acceleration time histories shall be recorded, and HIC shall be calculated. The first point of contact on the front structure of the vehicle shall be recorded. Recording of test results shall be in accordance with ISO 6487:2002.

7.3. Child headform test procedure

This test procedure is applicable with respect to the requirements of paragraphs 5.2.1. and 5.2.3.

7.3.1. Tests shall be made to the front structure within the boundaries as defined in paragraph 3.12. For tests on the rear area of the bonnet top, the headform impactor shall not contact the windscreen or A-pillar before impacting the bonnet top.

7.3.2. No impact point shall be located so that the impactor will impact the test area with a glancing blow resulting in a more severe second impact outside the test area.

Selected impact points on the bonnet for the child headform impactor shall be, at the time of first contact:

- (1) a minimum of 82.5 mm inside the defined side reference lines, and;
- (2) forward of the WAD1700 line, or,
a minimum of 82.5 mm forwards of the bonnet rear reference line,
- whichever is most forward at the point of measurement, and;
- (3) be rearward of the WAD1000 line, or,
a minimum of 82.5 mm rearwards of the bonnet leading edge reference line,
- whichever is most rearward at the point of measurement.

These minimum distances are to be set with a flexible tape held tautly along the outer surface of the vehicle.

7.3.3. The point of first contact of the headform impactor shall be within a ± 10 mm tolerance to the selected impact point.

7.3.4. The headform velocity at the time of impact shall be 9.7 ± 0.2 m/s.

7.3.5. The direction of impact shall be in the longitudinal vertical plane of the vehicle to be tested at an angle of $50 \pm 2^\circ$ to the horizontal. The direction of impact of tests to the front structure shall be downward and rearward.

7.4. Adult headform test procedure:

This test procedure is applicable with respect to the requirements of paragraphs 5.2.2. and 5.2.3.

7.4.1. Tests shall be made to the front structure within the boundaries as defined in paragraph 3.1. For tests at the rear of the bonnet top, the headform impactor shall not contact the windscreen or A-pillar before impacting the bonnet top.

7.4.2. No impact point shall be located so that the impactor will impact the test area with a glancing blow resulting in a more severe second impact outside the test area.

Selected impact points on the bonnet for the adult headform impactor shall be, at the time of first contact:

- (1) a minimum of 82.5 mm inside the defined side reference lines, and;
- (2) forward of the WAD2100 line, or,
a minimum of 82.5 mm forward of the bonnet rear reference line,
- whichever is most forward at the point of measurement, and;
- (3) rearward of the WAD1700 line.

These minimum distances are to be set with a flexible tape held tautly along the outer surface of the vehicle.

7.4.3. The point of first contact of the headform impactor shall be within a ± 10 mm tolerance to the selected impact point.

7.4.4. The headform velocity at the time of impact shall be 9.7 ± 0.2 m/s.

7.4.5. The direction of impact shall be in the longitudinal vertical plane of the vehicle to be tested at an angle of $65 \pm 2^\circ$ to the horizontal. The direction of impact of tests to the front structure shall be downward and rearward.

8. CERTIFICATION OF IMPACTORS

The impactors that are used in the tests described in this gtr are required to comply with the following performance requirements.

The requirements for the lower legform impactor are specified in paragraph 8.1., the upper legform impactor requirements are specified in paragraph 8.2. and the adult and child headform impactors requirements are specified in paragraph 8.3.

8.1. Lower legform impactor certification

8.1.1. Static tests

8.1.1.1. The lower legform impactor shall meet the requirements specified in paragraph 8.1.1.2. when tested as specified in paragraph 8.1.1.4. and the requirements specified in paragraph 8.1.1.3. when tested as specified in paragraph 8.1.1.5.

For both tests the impactor shall have the intended orientation about its longitudinal axis, for the correct operation of its knee joint, with a tolerance of $\pm 2^\circ$.

The stabilized temperature of the impactor during certification shall be $20 \pm 2^\circ\text{C}$.

The CAC response values, as defined in ISO 6487:2002 shall be 50° for the knee bending angle and 500 N for the applied force when the impactor is loaded in bending in accordance with paragraph 8.1.1.4., and 10 mm for the shearing displacement and 10 kN for the applied force when the impactor is loaded in shearing in accordance with paragraph 8.1.1.5. For both tests low-pass filtering at an appropriate frequency is permitted, to remove higher frequency noise without significantly affecting the measurement of the response of the impactor.

8.1.1.2. When the impactor is loaded in bending in accordance with paragraph 8.1.1.4., the applied force/bending angle response shall be within the limits shown in Figure 18. Also, the energy taken to generate 15.0° of bending shall be 100 ± 7 J.

8.1.1.3. When the impactor is loaded in shearing in accordance with paragraph 8.1.1.5., the applied force/shearing displacement response shall be within the limits shown in Figure 19.

8.1.1.4. The impactor, without foam covering and skin, shall be mounted with the tibia firmly clamped to a fixed horizontal surface and a metal tube connected firmly to the femur, as shown in Figure 20. The rotational axis of impactor knee joint shall be vertical. To avoid friction errors, no support shall be provided to the femur section or the metal tube. The bending moment applied at the centre of the knee joint, due to the mass of the metal tube and other components (excluding the legform itself), shall not exceed 25 Nm.

A horizontal normal force shall be applied to the metal tube at a distance of 2.0 ± 0.01 m from the centre of the knee joint and the resulting angle of knee deflection shall be recorded. The load shall be increased at a rate **between 1.0 and 10 %/s** until the angle of deflection of the knee is in excess of 22° . **Brief excursions from these limits due, for instance, to the use of a hand-pump shall be permitted.**

The energy is calculated by integrating the force with respect to the bending angle in radians, and multiplying by the lever length of 2.0 ± 0.01 m.

8.1.1.5. The impactor, without foam covering and skin, shall be mounted with the tibia firmly clamped to a fixed horizontal surface and a metal tube connected firmly to the femur and restrained at 2.0 m from the centre of the knee joint, as shown in Figure 21.

A horizontal normal force shall be applied to the femur at a distance of 50 mm from the centre of the knee joint and the resulting knee shearing displacement shall be recorded. The load shall be increased **between 0.1 and 20 mm/s** until the shearing displacement of the knee is in excess of **7.0 mm** or the load is in excess of 6.0 kN. **Brief excursions from these limits due, for instance, to the use of a hand-pump shall be permitted.**

8.1.2. Dynamic tests

8.1.2.1. The lower legform impactor shall meet the requirements specified in paragraph 8.1.2.3. when tested as specified in paragraph 8.1.2.4.

8.1.2.2. Calibration

8.1.2.2.1. The foam flesh for the test impactor shall be stored during a period of at least four hours in a controlled storage area with a stabilized humidity of 35 ± 10 percent and a stabilized temperature of $20 \pm 2^{\circ}\text{C}$ prior to impactor removal for calibration. The test impactor itself shall have a temperature of $20 \pm 2^{\circ}\text{C}$ at the time of impact. The temperature tolerances for the test impactor shall apply at a relative humidity of 40 ± 30 percent after a soak period of at least four hours prior to their application in a test.

8.1.2.2.2. The test facility used for the calibration test shall have a stabilized humidity of 40 ± 30 percent and a stabilized temperature of $20 \pm 4^{\circ}\text{C}$ during calibration.

8.1.2.2.3. Each calibration shall be completed within two hours of when the impactor to be calibrated is removed from the controlled storage area.

8.1.2.2.4. Relative humidity and temperature of the calibration area shall be measured at the time of calibration and recorded in a calibration report.

8.1.2.3. Requirements

8.1.2.3.1. When the impactor is impacted by a linearly guided certification impactor, as specified in paragraph 8.1.2.4., the maximum upper tibia acceleration shall be not less than 120 g and not more than 250 g. The maximum bending angle shall be not less than 6.2° and not more than 8.2° . The maximum shearing displacement shall be not less than 3.5 mm and not more than 6.0 mm.

For all these values, the readings used shall be from the initial impact with the certification impactor and not from the arresting phase. Any system used to arrest the impactor or certification impactor shall be so arranged that the arresting phase

does not overlap in time with the initial impact. The arresting system shall not cause the transducer outputs to exceed the specified CAC.

8.1.2.3.2. The instrumentation response value CFC, as defined in ISO 6487:2002, shall be 180 for all transducers. The CAC response values, as defined in ISO 6487:2002, shall be 50° for the knee bending angle, 10 mm for the shearing displacement and 500 g for the acceleration. This does not require that the impactor itself be able to physically bend and shear to these angles and displacements.

8.1.2.4. Test procedure

8.1.2.4.1. The impactor, including foam covering and skin, shall be suspended horizontally by three wire ropes of 1.5 ± 0.2 mm diameter and of 2000 mm minimum length, as shown in Figure 22. It shall be suspended with its longitudinal axis horizontal, with a tolerance of $\pm 0.5^\circ$, and perpendicular to the direction of the certification impactor motion, with a tolerance of $\pm 2^\circ$. The impactor shall have the intended orientation about its longitudinal axis, for the correct operation of its knee joint, with a tolerance of $\pm 2^\circ$. The impactor must meet the requirements of paragraph 6.3.1.1., with the attachment bracket(s) for the wire ropes fitted.

8.1.2.4.2. The certification impactor shall have a mass of 9.0 ± 0.05 kg, this mass includes those propulsion and guidance components which are effectively part of the impactor during impact. The dimensions of the face of the certification impactor shall be as specified in Figure 23. The face of the certification impactor shall be made of aluminium, with an outer surface finish of better than 2.0 micrometers.

The guidance system shall be fitted with low friction guides, insensitive to off-axis loading, that allow the impactor to move only in the specified direction of impact, when in contact with the vehicle. The guides shall prevent motion in other directions including rotation about any axis.

8.1.2.4.3. The impactor shall be certified with previously unused foam.

8.1.2.4.4. The impactor foam shall not be excessively handled or deformed before, during or after fitting.

8.1.2.4.5. The certification impactor shall be propelled horizontally at a velocity of 7.5 ± 0.1 m/s into the stationary impactor as shown in Figure 22. The certification impactor shall be positioned so that its centreline aligns with a position on the tibia centreline of 50 mm from the centre of the knee, with tolerances of ± 3 mm laterally and ± 3 mm vertically.

8.2. Upper legform impactor certification

8.2.1. The upper legform impactor shall meet the requirements specified in paragraph 8.2.3 when tested as specified in paragraph 8.2.4.

8.2.2. Calibration

8.2.2.1. The foam flesh for the test impactor shall be stored during a period of at least four hours in a controlled storage area with a stabilized humidity of 35 ± 10 percent and a stabilized temperature of $20 \pm 2^{\circ}\text{C}$ prior to impactor removal for calibration. The test impactor itself shall have a temperature of $20 \pm 2^{\circ}\text{C}$ at the time of impact. The temperature tolerances for the test impactor shall apply at a relative humidity of 40 ± 30 percent after a soak period of at least four hours prior to their application in a test.

8.2.2.2. The test facility used for the calibration test shall have a stabilized humidity of 40 ± 30 percent and a stabilized temperature of $20 \pm 4^{\circ}\text{C}$ during calibration.

8.2.2.3. Each calibration shall be completed within two hours of when the impactor to be calibrated is removed from the controlled storage area.

8.2.2.4. Relative humidity and temperature of the calibration area shall be measured at the time of calibration, and recorded in a calibration report.

8.2.3. Requirements

8.2.3.1. When the impactor is propelled into a stationary cylindrical pendulum the peak force measured in each load transducer shall be not less 1.20 kN and not more than 1.55 kN and the difference between the peak forces measured in the top and bottom load transducers shall not be more than 0.10 kN. Also, the peak bending moment measured by the strain gauges shall not be less than 190 Nm and not more than 250 Nm on the centre position and not less than 160 Nm and not more than 220 Nm for the outer positions. The difference between the upper and lower peak bending moments shall not be more than 20 Nm.

For all these values the readings used shall be from the initial impact with the pendulum and not from the arresting phase. Any system used to arrest the impactor or pendulum shall be so arranged that the arresting phase does not overlap in time with the initial impact. The arresting system shall not cause the transducer outputs to exceed the specified CAC.

8.2.3.2. The instrumentation response value CFC, as defined in ISO 6487:2002, shall be 180 for all transducers. The CAC response values, as defined in ISO 6487:2002, shall be 10 kN for the force transducers and 1000 Nm for the bending moment measurements.

8.2.4. Test procedure

8.2.4.1. The impactor shall be mounted to the propulsion and guidance system, by a torque limiting joint. The torque limiting joint shall be set so that the longitudinal axis of the front member is perpendicular to the axis of the guidance system, with a tolerance of $\pm 2^{\circ}$, with the joint friction torque set to 675 ± 25 Nm. The guidance system shall be fitted with low friction guides that allow the impactor to move only in the specified direction of impact, when in contact with the pendulum.

- 8.2.4.2. The impactor mass shall be adjusted to give a mass of 12 ± 0.1 kg, this mass includes those propulsion and guidance components which are effectively part of the impactor during impact.
- 8.2.4.3. The centre of gravity of those parts of the impactor which are effectively forward of the torque limiting joint, including the extra mass fitted, shall lie on the longitudinal centreline of the impactor, with a tolerance of ± 10 mm.
- 8.2.4.4. The impactor shall be certified with previously unused foam.
- 8.2.4.5. The impactor foam shall not be excessively handled or deformed before, during or after fitting.
- 8.2.4.6. The impactor with the front member vertical shall be propelled horizontally at a velocity of 7.1 ± 0.1 m/s into the stationary pendulum as shown in Figure 24.
- 8.2.4.7. The pendulum tube shall have a mass of 3 ± 0.03 kg, a wall thickness of 3 ± 0.15 mm and an outside diameter of $150 \text{ mm}^{+1 \text{ mm}}_{-4 \text{ mm}}$. Total pendulum tube length shall be 275 ± 25 mm. The pendulum tube shall be made from cold finished seamless steel (metal surface plating is permissible for protection from corrosion), with an outer surface finish of better than 2.0 micrometers. It shall be suspended on two wire ropes of 1.5 ± 0.2 mm diameter and of 2.0 m minimum length. The surface of the pendulum shall be clean and dry. The pendulum tube shall be positioned so that the longitudinal axis of the cylinder is perpendicular to the front member (i.e. level), with a tolerance of $\pm 2^\circ$, and to the direction of impactor motion, with a tolerance of $\pm 2^\circ$, and with the centre of the pendulum tube aligned with the centre of the impactor front member, with tolerances of ± 5 mm laterally and ± 5 mm vertically.

8.3. Child and adult headform impactors certification

8.3.1. Drop test

8.3.1.1. Performance Criteria

The headform impactors shall meet the requirements specified in paragraph 8.3.2., when tested as specified in paragraph 8.3.3.

8.3.2. Requirements

8.3.2.1. When the headform impactors are dropped from a height of 376 ± 1 mm in accordance with paragraph 8.3.3., the peak resultant acceleration measured by one triaxial (or three uniaxial) accelerometer (accelerometers) in the headform impactor shall be:

- for the child headform impactor not less than 245 g and not more than 300 g;
- for the adult headform impactor not less than 225 g and not more than 275 g.

The acceleration time curve shall be uni-modal.

8.3.2.2. The instrumentation response values CFC and CAC for each accelerometer shall be 1000 Hz and 500 g respectively as defined in ISO 6487:2002.

8.3.2.3. Temperature conditions

The headform impactors shall have a temperature of $20 \pm 2^{\circ}\text{C}$ at the time of impact. The temperature tolerances shall apply at a relative humidity of 40 ± 30 percent after a soak period of at least four hours prior to their application in a test.

8.3.2.4. After complying with the certification test, each headform impactor can be used for a maximum of 20 impact tests.

8.3.3. Test Procedure

8.3.3.1. The headform impactor shall be suspended from a drop rig as shown in Figure 25.

8.3.3.2. The headform impactor shall be dropped from the specified height by means that ensure instant release onto a rigidly supported flat horizontal steel plate, over 50 mm thick and over 300 mm x 300 mm square which has a clean dry surface and a surface finish of between 0.2 and 2.0 micrometers.

8.3.3.3. The headform impactor shall be dropped with the rear face of the impactor at the test angle specified in paragraph 7.3.5. for the child headform impactor and in paragraph 7.4.5. for the adult headform impactor with respect to the vertical as shown in Figure 25. The suspension of the headform impactor shall be such that it does not rotate during the fall.

8.3.3.4. The drop test shall be performed three times, with the headform impactor rotated 120° around its symmetrical axis after each test.

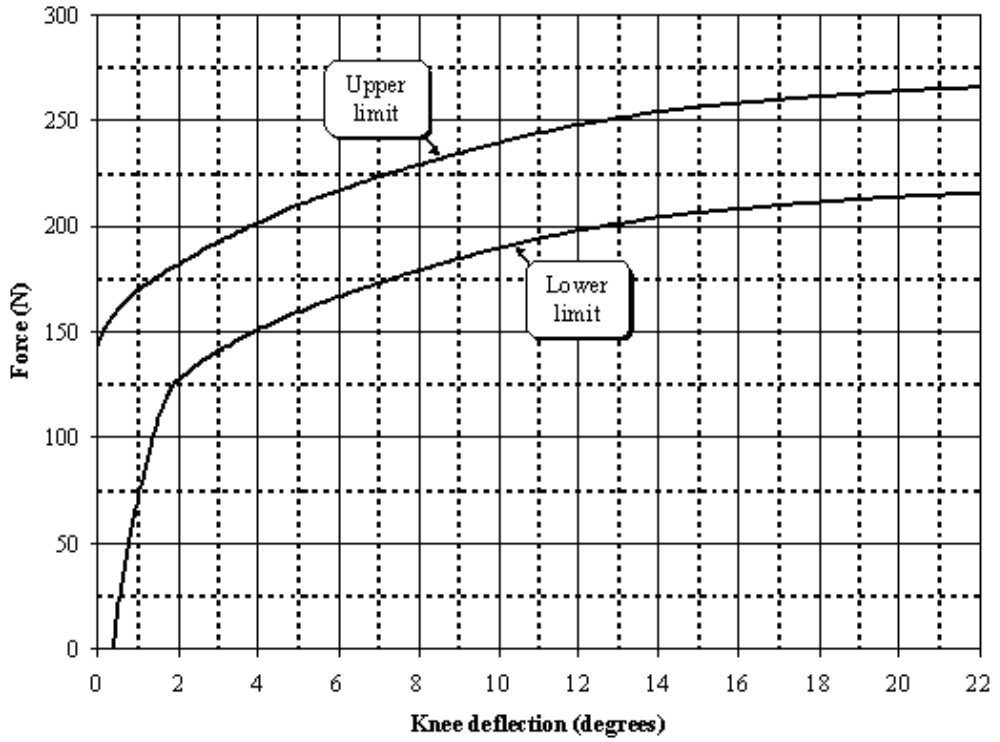

Figure 18. Force versus angle requirement in static lower legform impactor bending certification test (see paragraph 8.1.1.2.)

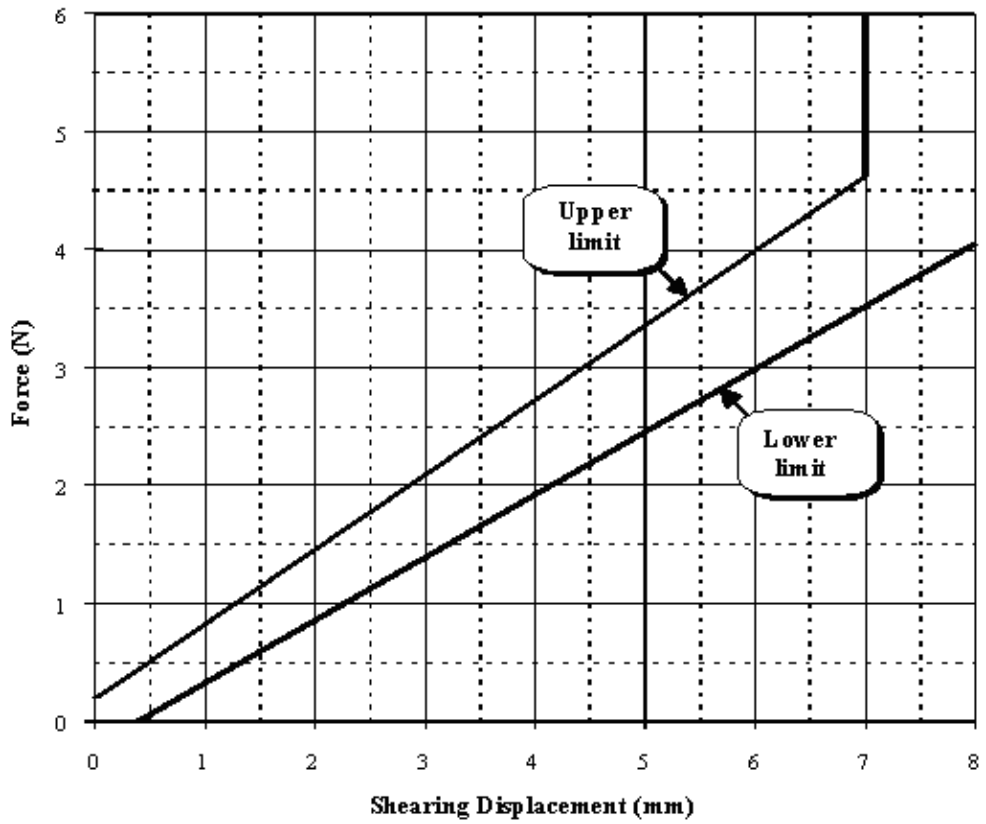

Figure 19. Force versus displacement requirement in static lower legform impactor shearing certification test (see paragraph 8.1.1.3.)

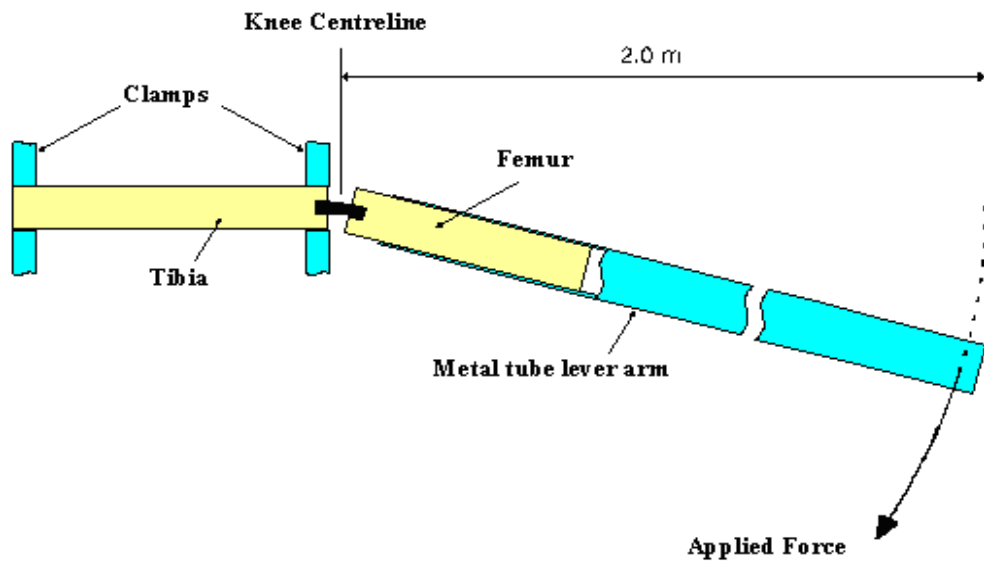

Figure 20. Top View of Test set-up for static lower legform impactor bending certification test (see paragraph 8.1.1.4.)

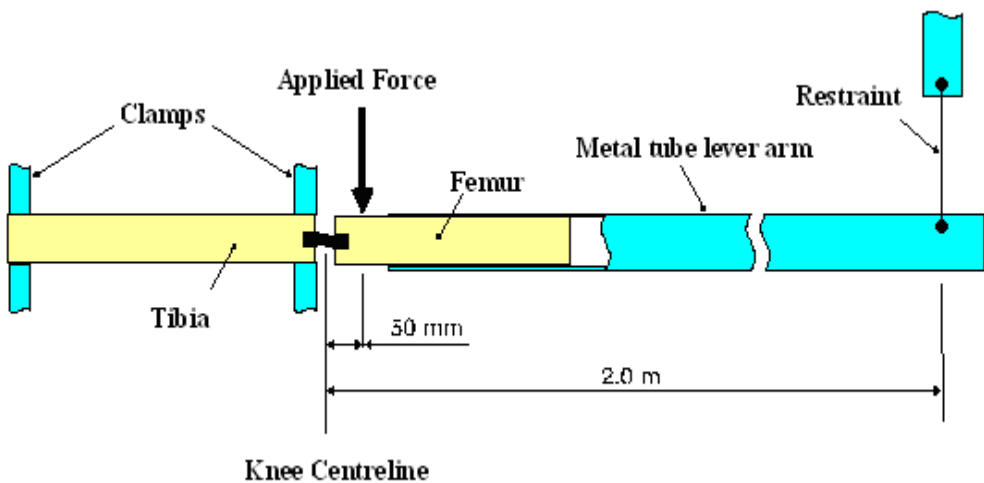

Figure 21. Top View of Test set-up for static lower legform impactor shearing certification test (see paragraph 8.1.1.5.)

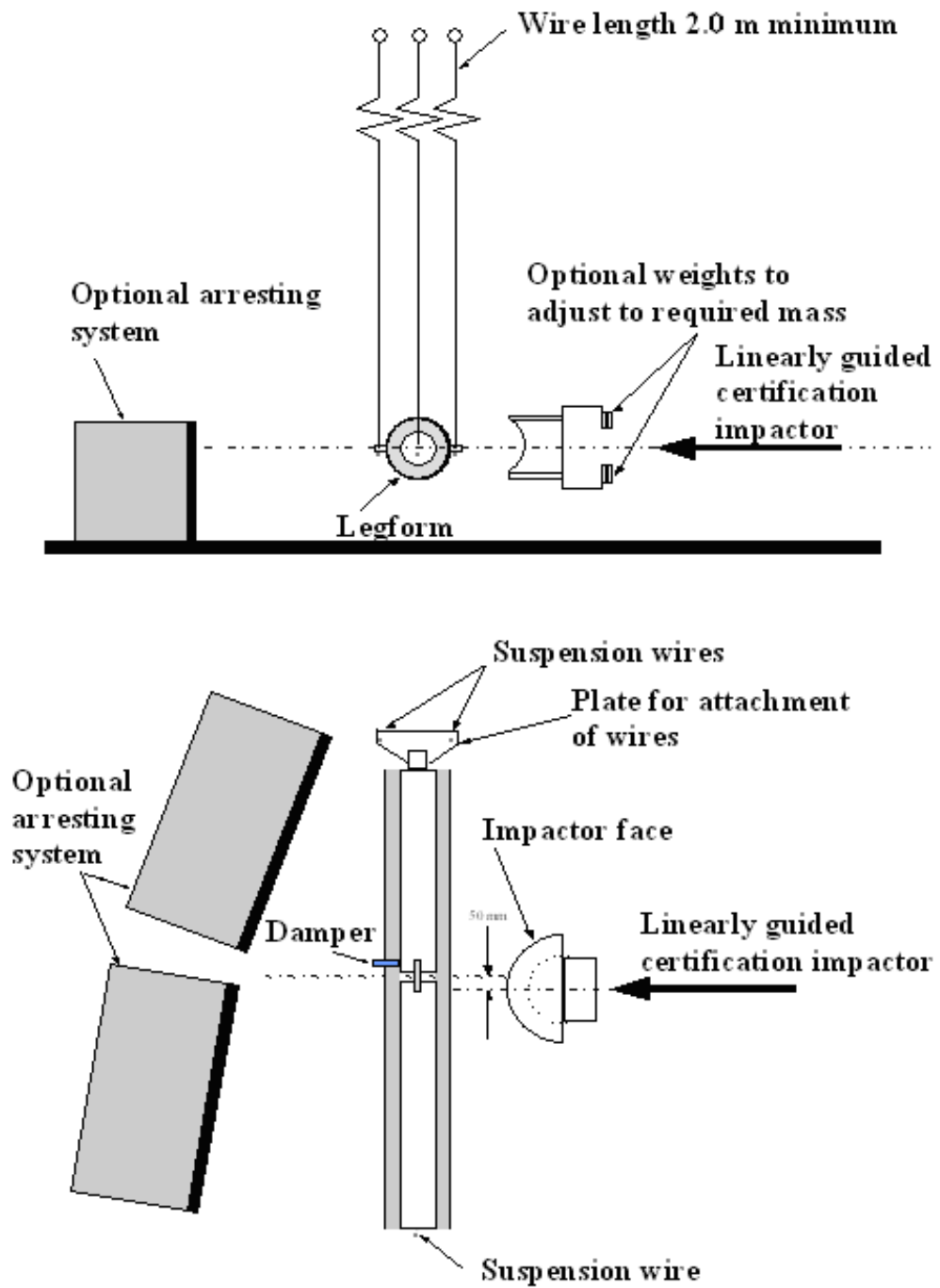

Figure 22. Test set-up for dynamic lower legform impactor certification test (side view top diagram, view from above bottom diagram) (see paragraph 8.1.2.4.1.)

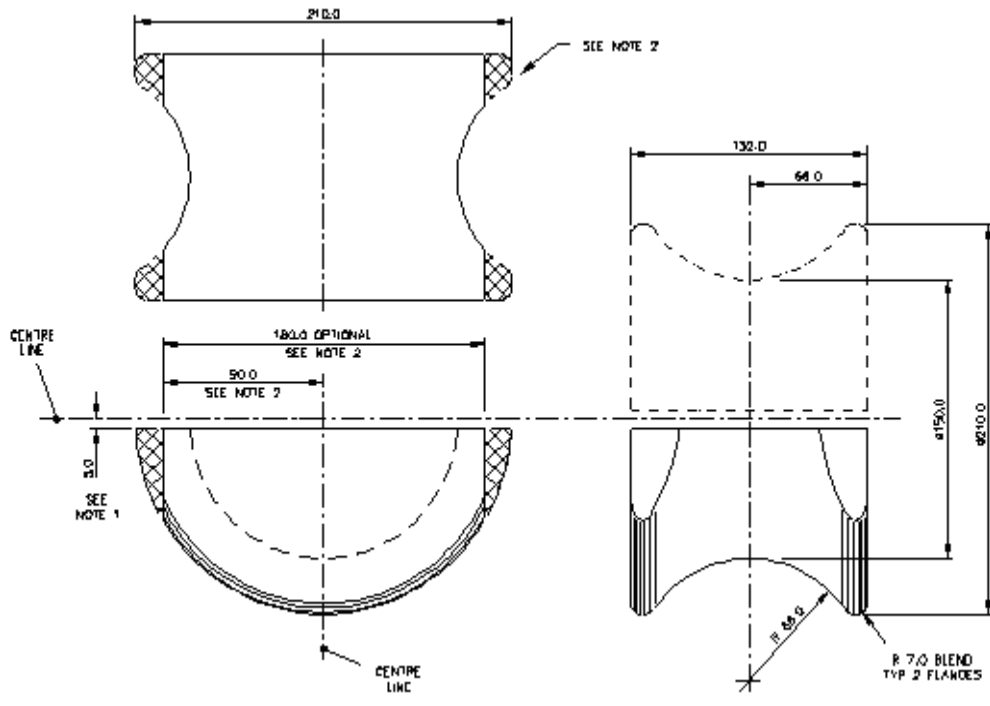

Figure 23. Details of dynamic lower legform certification impactor face (see paragraph 8.1.2.4.2.)

Notes:

1. Saddle may be made as a complete diameter and cut as shown to make two components.
 2. The shaded areas may be removed to give the alternative form shown.
 3. Tolerance on all dimensions is ± 1.0 mm.
- Material: Aluminium alloy.

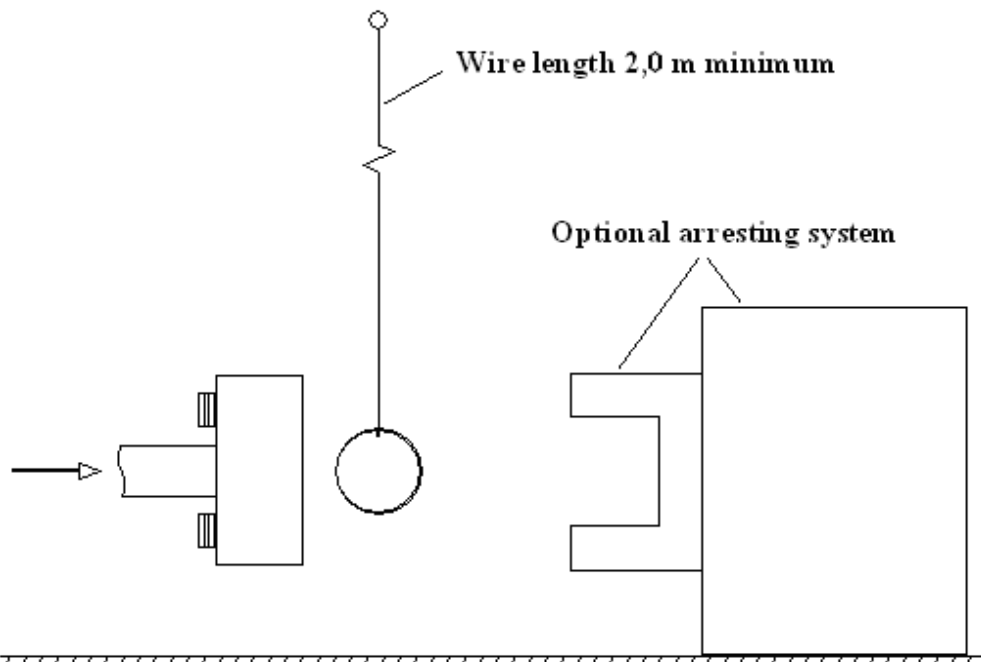

Figure 24. Test set-up for dynamic upper legform impactor certification test (see paragraph 8.2.4.6)

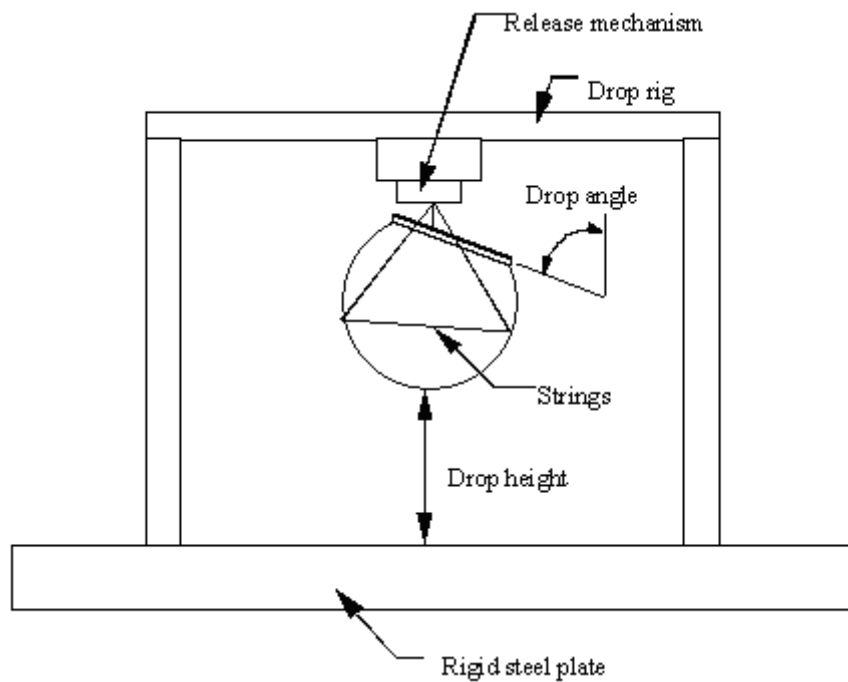

Figure 25. Test set-up for dynamic headform impactor biofidelity test (see paragraph 8.3.3.1.)
