



**Economic and Social
Council**

Distr.
GENERAL

ECE/TRANS/WP.29/GRSP/2007/17
28 September 2007

Original: ENGLISH
ENGLISH AND FRENCH ONLY

ECONOMIC COMMISSION FOR EUROPE

INLAND TRANSPORT COMMITTEE

World Forum for Harmonization of Vehicle Regulations

Working Party on Passive Safety

Forty-second session
Geneva, 11-14 December 2007
Item 17(b) of the provisional agenda

REGULATION No. 94
(Frontal collision)

Proposal for draft amendments

Proposal submitted by France^{*/}

The text reproduced below was prepared by the expert from France in order to replace the deformable element face, to change the test speed and overlap. It is based on a document distributed without a symbol (GRSP-41-25) during the forty-first session of the Working Party on Passive Safety (GRSP) (see report ECE/TRANS/WP.29/GRSP/41, paras. 56 and 66). The modifications to the current text of the Regulation are marked in **bold** or ~~strikethrough~~ characters.

^{*/} In accordance with the programme of work of the Inland Transport Committee for 2006-2010 (ECE/TRANS/166/Add.1, programme activity 02.4) In accordance with the programme of work of the Inland Transport Committee for 2006-2010 (ECE/TRANS/166/Add.1, programme activity 02.4), the World Forum will develop, harmonize and update Regulations in order to enhance performance of vehicles with respect to passive safety. The present document is submitted in conformity with that mandate.

A. PROPOSAL

Annex 3

Paragraph 1.3.1., amend to read:

"1.3.1. Alignment of the vehicle to the barrier

The vehicle shall overlap the barrier face by ~~40~~ **50** per cent \pm 20 mm."

Paragraph 4., amend to read:

"4. TEST SPEED

Vehicle speed at the moment of impact shall be ~~56~~ **60** -0/+1 km/h. However, if the test was performed at a higher impact speed and the vehicle met the requirements, the test shall be considered satisfactory."

Annex 9., amend to read:

"DEFINITION OF DEFORMABLE BARRIER

Characteristics of the deformable barrier

The PDB deformable barrier is a stacking of three deformable aluminium honeycomb cores. The first (front deformable core, 250 mm thick) is designed to provide a constant load in depth. The second (progressive deformable core, 450 mm thick) is designed to provide a progressive load in depth. The third (back deformable core, 90 mm thick) is designed to provide a constant load in depth. Aluminium honeycomb cores are bonded together with different aluminium sheets forming a ready to use deformable barrier to be fixed on a rigid wall.

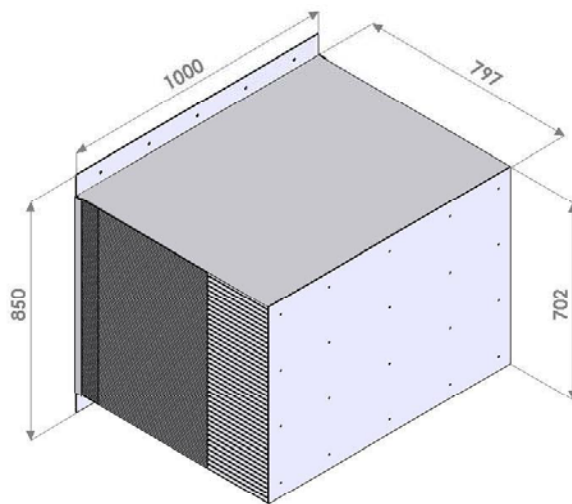

Figure 1: Barrier dimensions.

1. COMPONENT AND MATERIAL SPECIFICATIONS

The dimensions of the barrier are illustrated in Figure 1 of this annex. The dimensions of the individual components of the barrier are listed separately below.

The PDB barrier is composed of the following components:

- (1) One back plate,
- (2) One back deformable core,
- (3) Two intermediate plates,
- (4) One progressive deformable core,
- (5) One front deformable core,
- (6) One contact plate,
- (7) One outer cladding,
- (8) Blind rivets,
- (9) Epoxy resin.

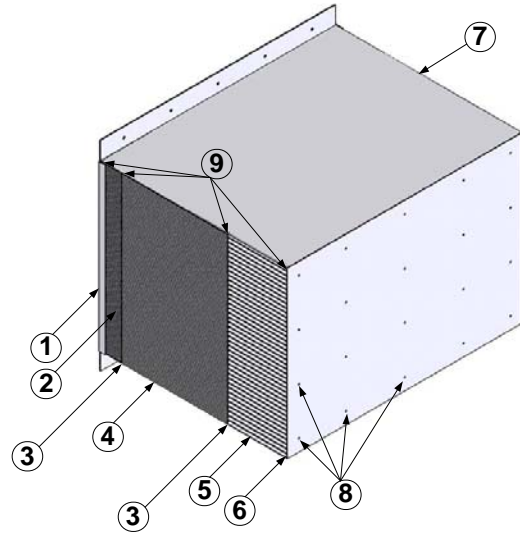

1.1. Back Plate geometrical and material characteristics (1)

The back plate is 1000 ± 2.5 mm wide and 850 ± 2.5 mm high. The thickness is 3 mm. The back plate is manufactured from Aluminum of 1050A H14.

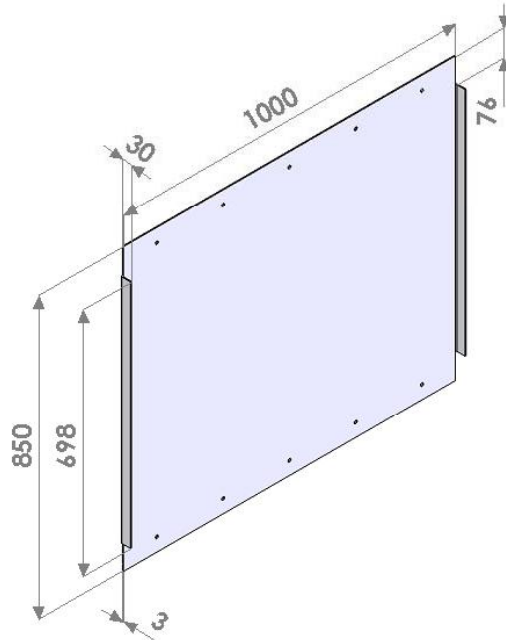

1.2. Intermediate Plate geometrical and material characteristics (3)

The intermediate plate is 1000 ± 2.5 mm wide and 700 ± 2.5 mm high. The thickness is 0.5 mm. The back plate is manufactured from Aluminum of 5754 H111.

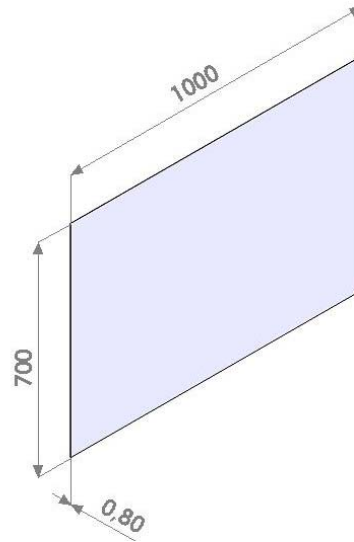

1.3. Contact plate geometrical and material characteristics (6)

The contact plate is 1000 ± 2.5 mm wide and 700 ± 2.5 mm high. The thickness is 1.5 mm. The contact plate is manufactured from Aluminum of 1050A H24.

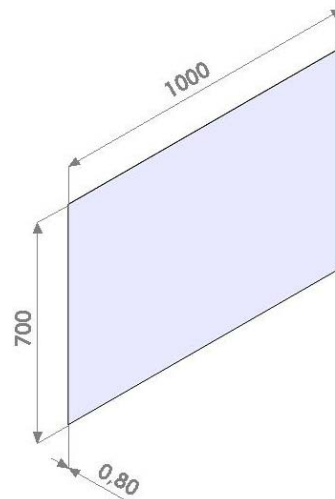

1.4. Cladding geometrical and material characteristics (7)

The cladding is 1000 ± 2.5 mm wide and 850 ± 2.5 mm high. The thickness is 0.8 mm. The cladding is manufactured from Aluminium of 5754 H22.

The cladding has two mounting flanges of 75 mm allowing rigid wall mounting. Twenty 6.2 mm holes shall be drilled through the outer cladding in order to accommodate front face blind rivets.

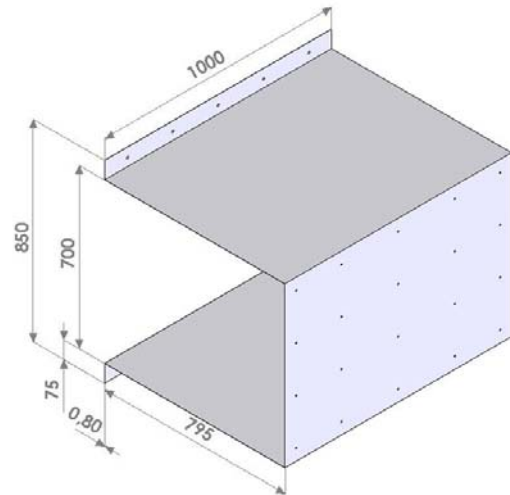

1.5. Rivets position (8)

Twenty blind rivets shall be used to improve the link between outer cladding and contact plate. Rivets shall be aluminum/steel blind rivets diameter 6 mm.

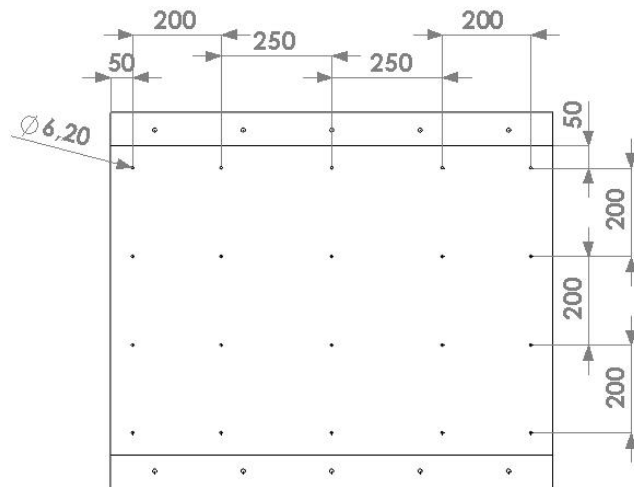

1.6. Adhesive (9)

The adhesive to be used shall be an Epoxy Resin type H9940 or equivalent.

1.7. Honeycomb deformable cores

Geometrical and material characteristics:

The PDB deformable barrier is a stacking of three deformable aluminium honeycomb cores and provides 4 different crushing strength areas (#1, #2, #3, #4) whose forms and positioning are shown below.

All honeycomb deformable cores shall be made of 3003 aluminium.

- (a) The cell dimensions for the front block shall be $19.1 \text{ mm} \pm 15$ percent.

- (b) The cell dimensions for the intermediate block shall be $9.5 \text{ mm} \pm 15 \text{ percent}$.
- (c) The cell dimensions for the rear block shall be $6.3 \text{ mm} \pm 15 \text{ percent}$.

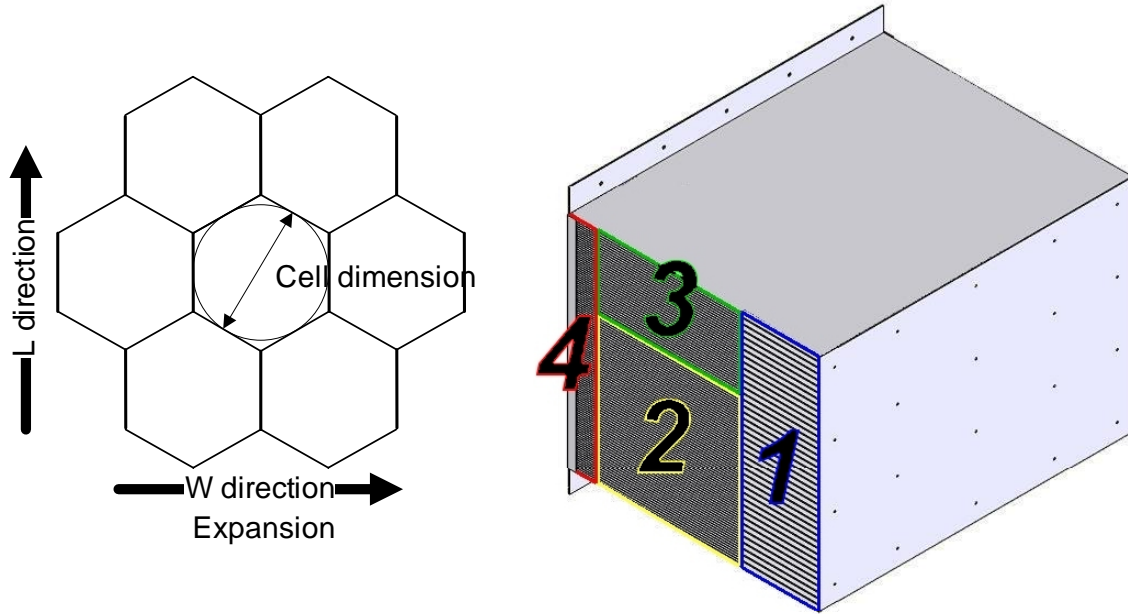

1.7.1. Front block (5)

The front block (area #1) shall be $700 \pm 5 \text{ mm}$ in L Direction, $1000 \pm 5 \text{ mm}$ in W direction and $250 \pm 1 \text{ mm}$ in T direction. The crushing characteristics of the front block are constant.

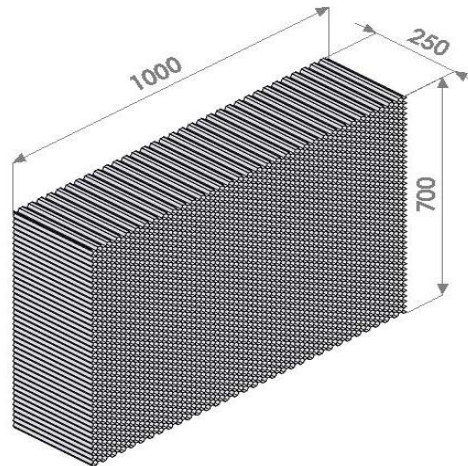

1.7.2. Progressive block (4)

The progressive block (area #2 and #3) shall be: 700 ± 5 mm in L direction, 1000 ± 5 mm in W direction and 450 ± 1 mm in T direction. The crushing characteristics of the progressive block present 2 different load paths. The lower load path #2, offers a progressive resistance in depth for first 350 mm and a constant resistance in depth for last 100 mm. The upper load path #3, offers a progressive resistance in depth for first 350 mm and a constant resistance in depth for last 100 mm.

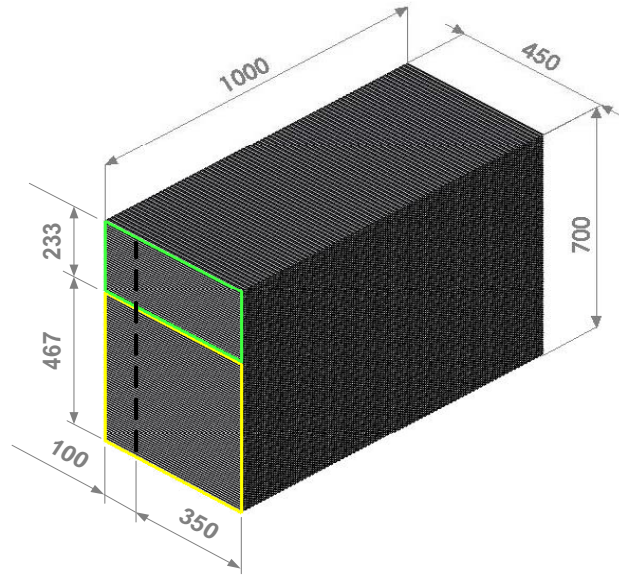

1.7.3. Back block (2)

The back block (area #4) shall be 700 ± 5 mm in L direction, 1000 ± 5 mm in W direction and 90 ± 1 mm in T direction. The crushing characteristics of the front block are constant.

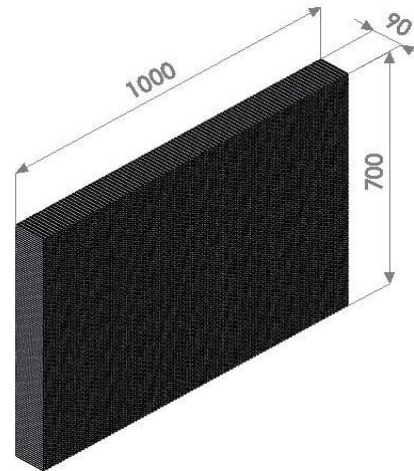

2. ALUMINIUM HONEYCOMB CERTIFICATION

The aluminum honeycomb blocks should be processed such that the force deflection-curve when statically crushed (according to the procedure defined below) is within the corridors defined for each of the three blocks. Samples taken from each batch of processed honeycomb core shall be tested.

2.1. Sample size

One sample for the front block (area #1): The sample size of the aluminium honeycomb for static tests shall be 200 mm in W direction x 200 mm in L direction x 250 mm in T direction for the front block.

Two samples for the progressive block: One sample for lower load path (area #2) and one sample for upper load path (area #3). The samples size of the aluminium honeycomb for static tests shall be at least 100 mm in W direction x 100 mm in L direction x 450 mm in T direction for the progressive block.

One sample for the back block (area #4): The sample size of the aluminium honeycomb for static tests shall be 100 mm in W direction x 100 mm in L direction x 90 mm in T direction for the back block.

2.2. Data collection and crush rate

The samples should be compressed between two parallel loading plates which are at least 20 mm larger than the block cross section. The compression speed shall be 100 mm/min, with a tolerance of 5 percent. The data acquisition for static compression shall be sampled at a minimum of 5 Hz. The static test shall be continued until the block compression is at least 80 percent of honeycomb core initial thickness.

2.3. Sample crush strength specification

The crush resistance curve for each block tested shall be included within the corridors defined below:

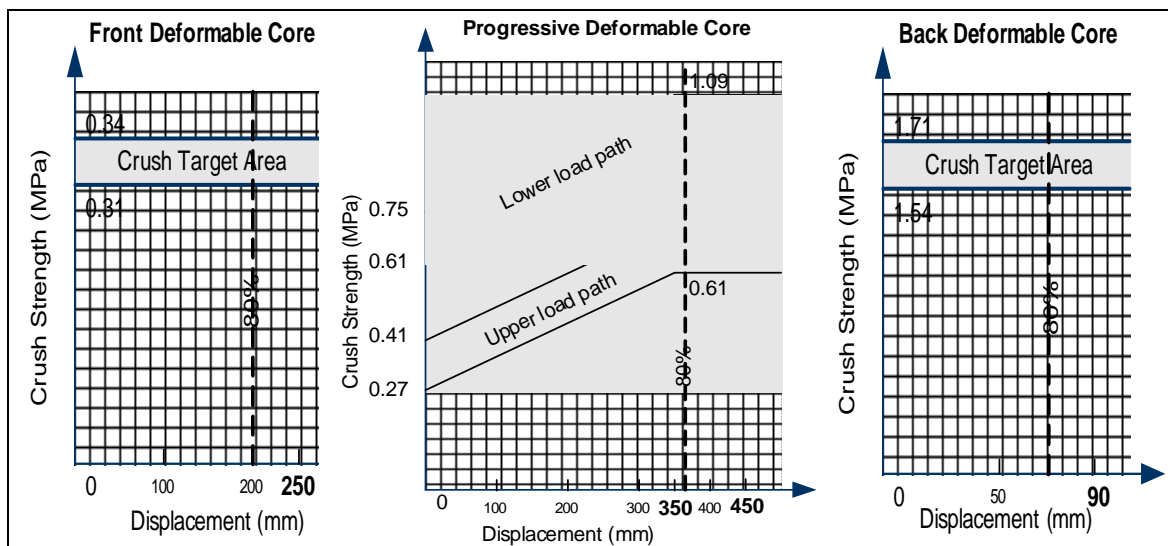

Figure 2: Crush strength specification for the different cores.

3. ADHESIVE BONDING PROCEDURE

3.1. Immediately before bonding, aluminum sheet surfaces to be bonded shall be thoroughly cleaned using a suitable **cleaning and degreasing solution**. This is to be carried out as required to eliminate grease or dirt deposits. The cleaned surfaces shall then be abraded using 120 grit abrasive paper. Metallic/Silicon Carbide abrasive paper is not to be used. The surfaces shall be thoroughly abraded and the abrasive paper changed regularly during the process to avoid clogging, which may lead to a polishing effect. Following abrading, the surfaces shall be thoroughly cleaned again, as above. All dust and deposits left as a result of the abrading process shall be removed, as these will adversely affect bonding.

3.2. The adhesive should be applied to one surface only. In cases where honeycomb is to be bonded to aluminum sheet, the adhesive should be applied to the aluminum sheet only. A maximum of 0.5 kg/m^2 shall be applied evenly over the surface, giving a maximum film thickness of 0.5 mm.

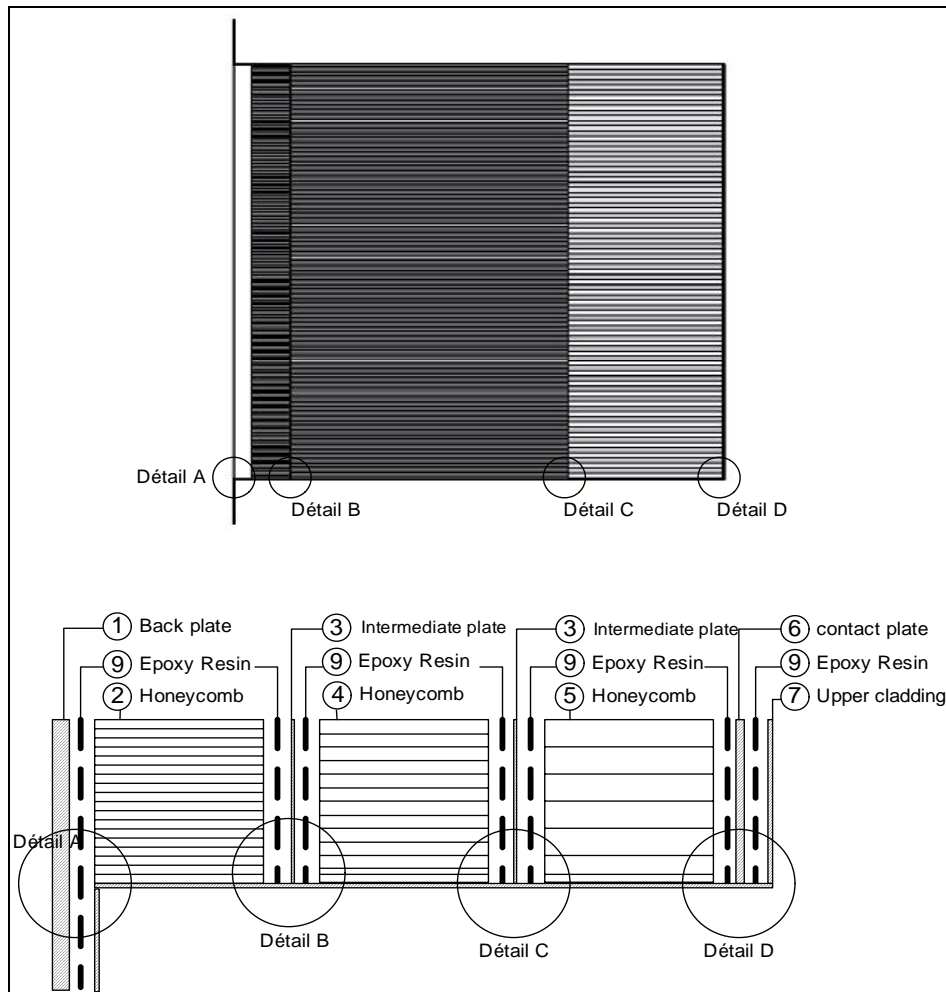

Figure 3: Gluing detail among the different parts.

4. CONSTRUCTION

- 4.1. The ~~main~~ honeycomb blocks shall be bonded to the sheets with adhesive such that the cell axes are perpendicular to the sheets. The **outer** cladding shall be bonded to the **contact plate**. The **upper** and **lower** surfaces of the outer cladding sheet shall not be bonded to the honeycomb blocks but should be positioned closely to it. The cladding sheet shall be adhesively bonded to the back plate at the mounting flanges.
- 4.2. **Clearance holes for mounting the barrier are to be drilled in the mounting flanges (shown in Figure 4). The holes shall be of 9.5 mm diameter. Five holes shall be drilled in the top flange at a distance of 40 mm from the top edge of the flange and five in the bottom flange, 40 mm from the bottom edge of that flange. The holes shall be at 100 mm, 300 mm, 500 mm, 700 mm, and 900 mm from either edge of the barrier. All holes shall be drilled to ± 1 mm of the nominal distances. These hole locations are a recommendation only. Alternative positions may be used which offer at least the mounting strength and security provided by the above mounting specifications.**

5. MOUNTING

- 5.1. The deformable barrier shall be rigidly fixed to the edge of a mass of not less than 7×10^4 kg or to some structure attached thereto. The attachment of the barrier face shall be such that the vehicle shall not contact any part of the structure more than 75 mm from the top surface of the barrier (excluding the upper flange) during any stage of the impact. ~~2/~~ The front face of the surface to which the deformable barrier is attached shall be flat and continuous over the height and width of the face and shall be vertical $\pm 1^\circ$ and perpendicular $\pm 1^\circ$ to the axis of the run-up track. The attachment surface shall not be displaced by more than 2 mm during the test. If necessary, additional anchorage or arresting devices shall be used to prevent displacement of the **stationary barrier structure**. The edge of the deformable barrier shall be aligned with the edge of the **stationary barrier structure** appropriate for the side of the vehicle to be tested.
- 5.2. The deformable barrier shall be fixed to the block by means of ten bolts, five in the top mounting flange and five in the bottom. These bolts shall be of at least 8 mm diameter. Steel clamping strips shall be used for both the top and bottom mounting flanges (see **Figures 3**). These strips shall be 60 mm high and 1000 mm wide and have a thickness of at least 3 mm. The edges of the clamping strips shall be rounded-off to prevent tearing of the barrier against the strip during impact. The edge of the strip **shall** be located no more than 5 mm above the base of the upper barrier-mounting flange, or 5 mm below the top of the lower barrier-mounting flange. Five clearance holes of 9.5 mm diameter must be drilled in both strips to correspond with those in the mounting flange on the barrier (see paragraph 4.). The mounting strip and barrier flange holes may be widened from 9.5 mm up to a

~~2/~~ A mass the end of which.....

exceed 5° and 2° in the horizontal plane.

- 6.1.1.2. The front and rear track width of the trolley shall be $1,500 \pm 10$ mm.
- 6.1.1.3. The wheelbase of the trolley shall be $3,000 \pm 10$ mm.
- 6.1.1.4. The centre of gravity shall be situated in the longitudinal median vertical plane within 10 mm, 700 ± 30 mm behind the front axle and 500 ± 30 mm above the ground.
- 6.1.1.5. The distance between the front face of the impactor and the centre of gravity of the barrier shall be $2,000 \pm 30$ mm.
- 6.1.2. Deformable barrier tested. The deformable barrier tested shall be representative of the series production of the barrier.
- 6.1.3. Attachment of the impactor
 - 6.1.3.1. The impactor shall be firmly attached to the trolley in such a way that no relative displacement occurs during the test.
 - 6.1.3.2. The angle between the longitudinal axis of the rigid wall and the direction of motion of the trolley shall be $0^{\circ} \pm 2^{\circ}$.
 - 6.1.3.3. The impactor consists of a rigid block defined in Figure 5. The material of the impactor must be in steel. The geometry of the impactor must respect the design in Figure 5.
- 6.1.4. Attachment of the deformable barrier. The deformable barrier shall be fixed on a rigid wall as specified in paragraph 5.
- 6.1.5. Test configuration
 - 6.1.5.1. The rigid wall shall overlap the right side of the barrier face by 700 ± 20 mm in Y axis (Figure 6).
 - 6.1.5.2. The velocity of the trolley at the moment of the impact shall be 60 km/h $-0/+1$ km/h. If the test was performed at a higher impact speed and the test results meet the requirements, the test shall be considered satisfactory.
- 6.1.6. Measurement to be made on the trolley. The position of the transducers measuring the deceleration of the Centre Of Gravity (COG) of the trolley during the impact shall be parallel to the longitudinal axis of the trolley (Channel Frequency Class (CFC) of 180).
- 6.1.7. Reference curve Global force vs. displacement. This displacement is obtained by integration of the deceleration curve of the COG of the trolley obtained. The

global crush force is obtained by the multiplication of the trolley acceleration in CFC of 60 by its mass.

- 6.1.8. **Equivalent method.** A dynamometric wall behind the barrier may measure the crush force calculation. The global force shall be calculated by the sum of different load cell wall measurements. The sum shall be processed with a CFC of 60 filter.
- 6.1.9. **Certification.** The force deflection curves of the barrier tested shall lie within the corridors defined in Figure 8.

Figure 5

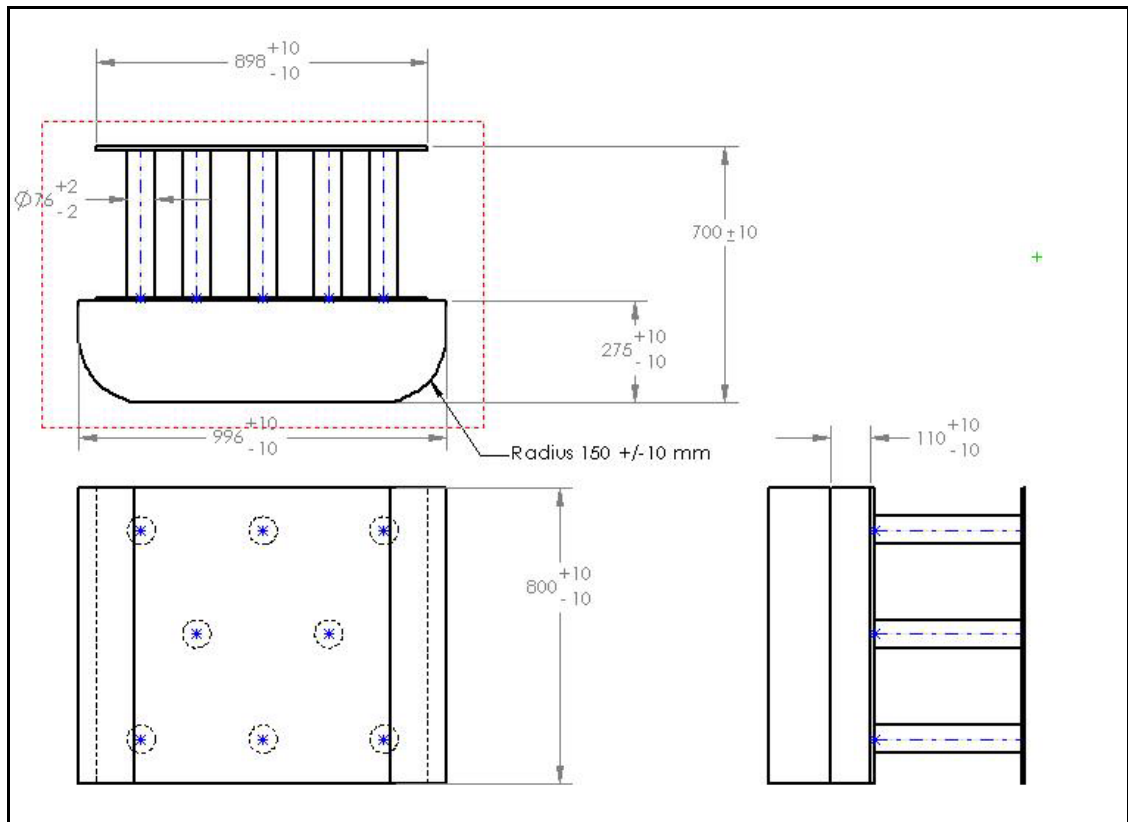

Figure 6

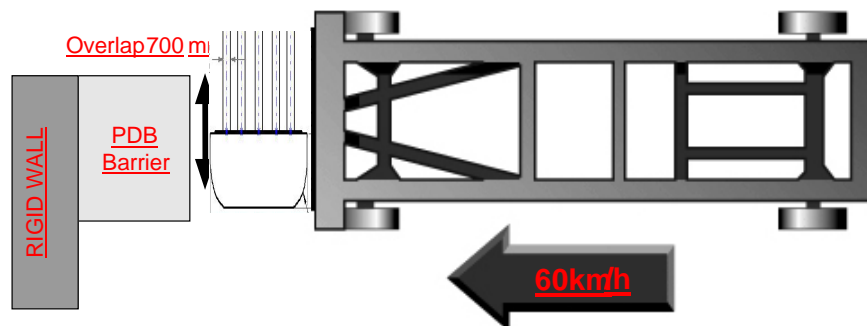
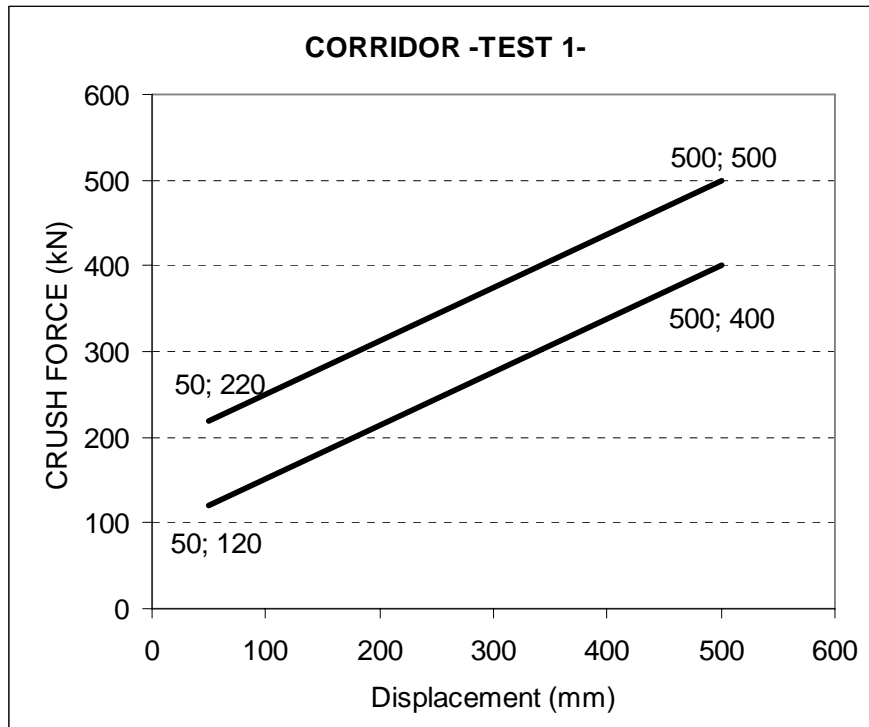

Figure 7



Figure 8



6.2. Test 2: Rigid tubular impactor

6.2.1. Characteristics of the mobile barrier

6.2.1.1. The total mass shall be 1,300 kg +/- 30 kg. The trolley shall be so constructed that no permanent deformation appears after the test. It shall be so guided that, during the impact phase, the deviation in the vertical plane does not exceed 5° and 2° in the horizontal plane.

6.2.1.2. The front and rear track width of the trolley shall be 1,500 ± 10 mm.

6.2.1.3. The wheelbase of the trolley shall be 3,000 ± 10 mm.

6.2.1.4. The centre of gravity shall be situated in the longitudinal median vertical plane within 10 mm, 950 ± 30 mm behind the front axle and 500 ± 30 mm above the ground.

6.2.1.5. The distance between the front face of the impactor and the centre of gravity of the barrier shall be 2,100 ± 30 mm.

6.2.2. Deformable barrier tested. The deformable barrier tested shall be representative of the series production of the barrier.

6.2.3. Attachment of the impactor

6.2.3.1. The impactor shall be firmly attached to the trolley in such a way that no relative displacement occurs during the test.

6.2.3.2. The angle between the longitudinal axis of the rigid wall and the direction of motion of the trolley shall be 0° ± 2°.

6.2.3.3. The impactor consists of a rigid block defined in Figure 9. The material of the impactor must be in steel. The geometry of the impactor must respect the design in Figure 9.

6.2.4. Attachment of the deformable barrier. The deformable barrier shall be fixed on a rigid wall as specified in paragraph 5.

6.2.5. Test configuration

6.2.5.1. The rigid wall shall overlap the right side of the barrier face by 800 +/- 20 mm in Y axis (Figure 10).

6.2.5.2. The velocity of the trolley at the moment of the impact shall be 60 km/h -0/+1 km/h. If the test was performed at a higher impact speed and the test results meet the requirements, the test shall be considered satisfactory.

- 6.2.6. Measurement to be made on the trolley. The position of the transducers measuring the deceleration of the Centre Of Gravity (COG) of the trolley during the impact shall be parallel to the longitudinal axis of the trolley (CFC of 180).
- 6.2.7. Reference curve Global force vs. displacement. This displacement is obtained by integration of the deceleration curve of the COG of the trolley obtained. The global crush force is obtained by the multiplication of the trolley acceleration in CFC of 60 by its mass.
- 6.2.8. Equivalent method. A dynamometric wall behind the barrier may measure the crush force calculation. The global force shall be calculated by the sum of different load cell wall measurements. The sum shall be processed with a CFC of 60 filter.
- 6.3. Validation
 - 6.3.1. The force deflection curves of the barrier tested shall lie within the force corridors defined in Figure 12.
 - 6.3.2. The barrier face deformation shall lay within the deformation defined in Figure 13.

Figure 9

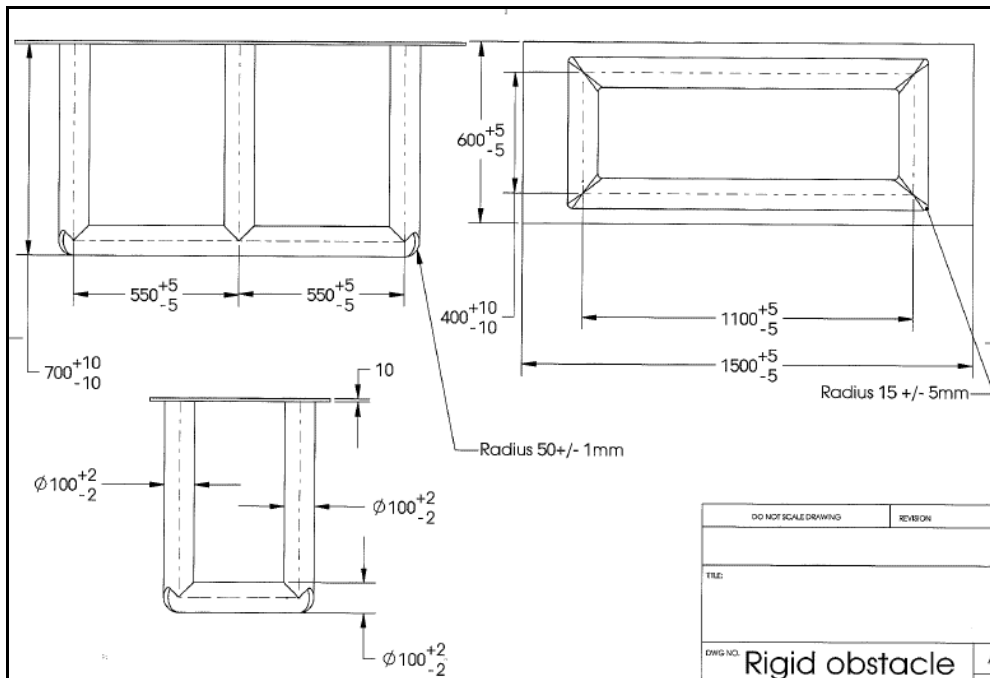

Figure 10

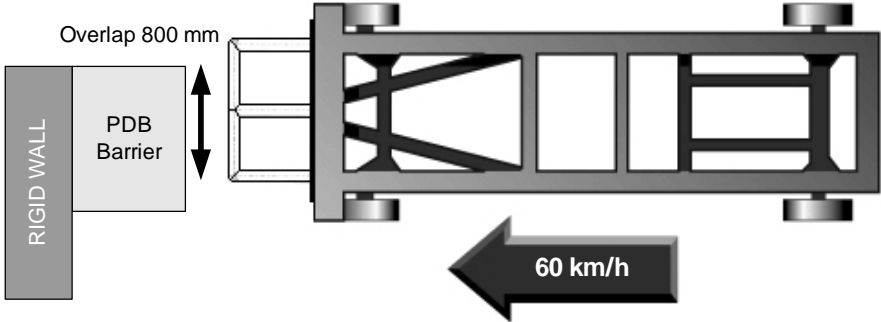

Figure 11



Figure 12

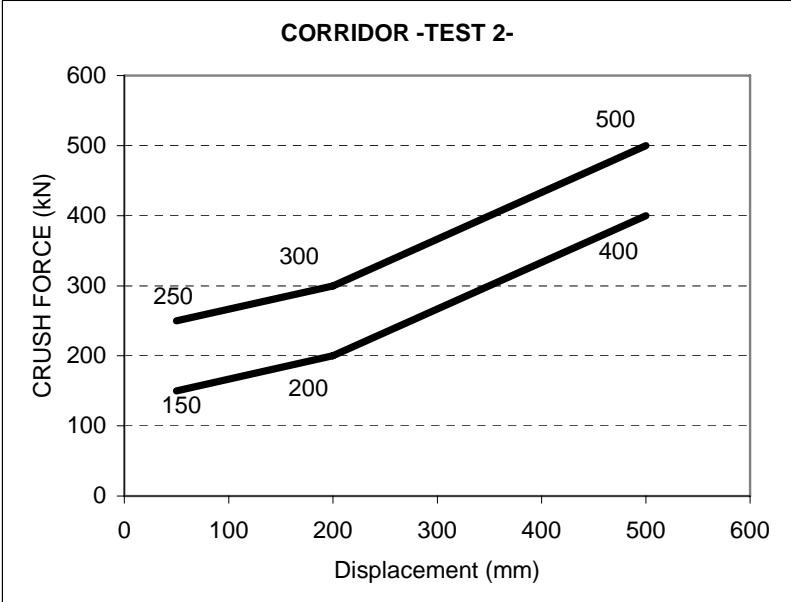
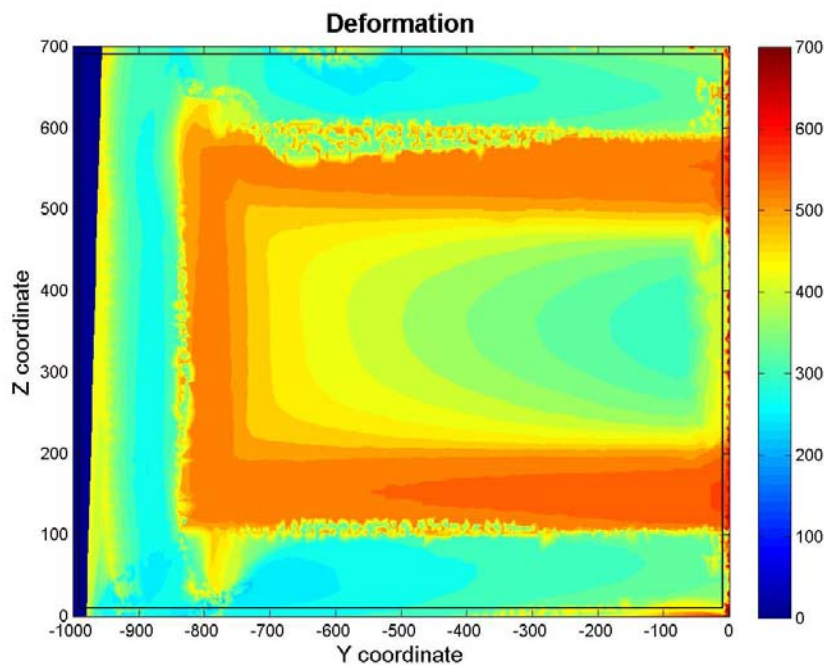

Figure 13



"

B. JUSTIFICATION

This document aims at clarifying the requirements for deformable barrier face, test speed and overlap change in Regulation No. 94. The Progressive Deformable Barrier (PDB) approach is explained in informal document GRSP-41-25 distributed during the 41st session of the Working Party on Passive Safety (GRSP) and the document "presentation of the status report of the Enhanced European Vehicle-safety Committee (EEVC) Working Group 15 (WG15) on Compatibility and Frontal Impact activities" (38th GRSP session).

The present amendment is aimed at reinforcing passive safety performance of modern vehicles and harmonising front-end force of the future fleet according to the EEVC WG15 and past EEVC Working Group 16 (Frontal Impact) conclusions mentioned in the following paragraphs. Furthermore, when Regulation No. 94 (Frontal collision) was first introduced, the European Commission wanted to review certain technical aspects, especially the test speed and the barrier design after a period of implementation.

In 2000, EEVC WG16 recommended not to raise the test speed to 60 km/h until there is a better understanding of compatibility. WG16 reported: "barrier instability for new generation of car and a barrier, stiffness too low for modern vehicles (as they bottom out the barrier), was not the original intent".

Following this remark and after having investigated compatibility issue, EEVC WG 15 recommended, "the test speed of the current offset test (Regulation No. 94) must not be raised to 60 km/h without modification of the current test procedure".

In 2005, WG15 added "the current test speed for regulation cannot be increased using the existing UNECE Regulation No. 94 barrier without increasing the existing discrepancy in frontal stiffness and aggressiveness for the vehicle fleet". As vehicles get heavier and stiffer, the current deformable barrier used for the evaluation of frontal offset crash protection bottoms out; as a consequence, the test becomes more severe for heavier vehicles.

Barrier problems in the current Regulation No. 94, listed by EEVC WG15 in its final report in May 2007:

- (a) Barrier instability for new generation of car, stiffness of barrier too low for modern vehicles.
- (b) Test severity increases with car mass with constant test speed and makes force matching unreachable.
- (c) Self-protection level depends on the vehicle size and mass.
- (d) Difficult to assess force levels with this barrier type and configuration with constant speed tests (bottoming out of barrier causes undesired inertial loads for measurement of a cars frontal force).
- (e) No structural interaction is potentially possible because of load spreading in the barrier and subsequent barrier bottoming out.

Proposed changes

According to EEVC WG15 and WG16 recommendations, modifications were proposed:

- (a) Test parameters: test speed, overlap and barrier ground clearance.
- (b) Obstacle: new barrier design (PDB).

Overlap and ground clearance

The 50 per cent overlap and 150 mm ground clearance ensures that the full front of the vehicle is in direct contact with the barrier when tested in offset conditions. Figures 1 below was realised with data collected in the Structural database of the "Vehicle Crash Compatibility" project (VC-Compat) validated by EEVC WG15 and presented on informal document GRSP-41-25 (41st GRSP session) and the document "presentation of the status report of EEVC WG15 activities" (38th GRSP session).

Relative position of the vehicle front end structure in front of the barrier:

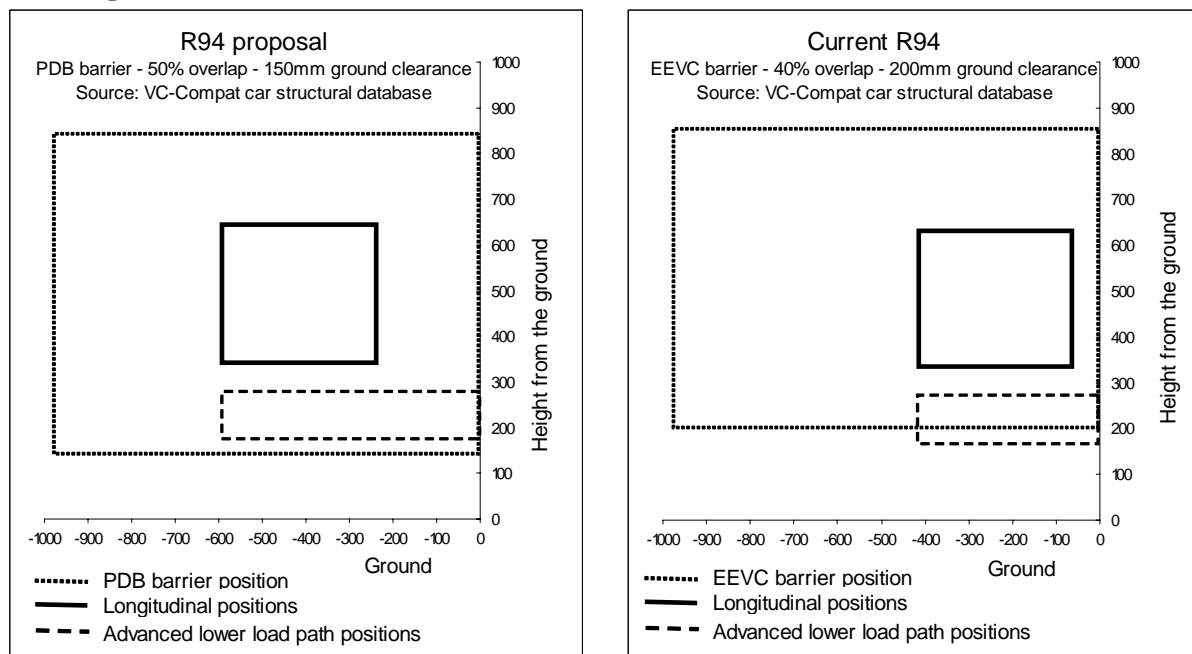

Figure 1: Relative position area of side members and lower load paths in front of the barrier. Source: VC-Compat structural database.

The 50 per cent overlap associated with the 150 mm ground clearance represents a minor change in terms of dynamic and kinematics, but a huge improvement for evaluating front-end design. In this position, the barrier is now able to check the stability of all main load paths (side members, cross members, cradle sub frame, blocker beam, advance lower load paths etc.) and all vehicle architectures (body on frame, longitudinal engine etc.).

Test speed and barrier design

The PDB test is an overlap offset test at 60 km/h. The barrier stiffness increases with crush depth and also provides different force deflection characteristics in the upper and lower sections of the barrier. The PDB barrier was designed to harmonize the test severity among vehicles of different masses (Figure 2); it will encourage lighter vehicles to be stronger without increasing the force levels of heavy vehicles (Figure 3) that lead to better force matching, first step towards compatibility. Furthermore, the dimensions and stiffness of the PDB make the bottoming-out phenomenon very unlikely. The barrier face is capable of generating sufficient differential deformation of the weak and stiff parts of the car's front structure to replicate what happens in most accidents. This will encourage future car designs to incorporate structures, which distribute the force on a large surface better for structural interaction and partner protection. Its potential for harmonisation is important.

Test severity comparison with deformable element

The combination of higher test speed and the introduction of the PDB barrier introduction increase the test severity for light vehicles without changing heavy one's. Test severity for all vehicle mass range will be harmonised.

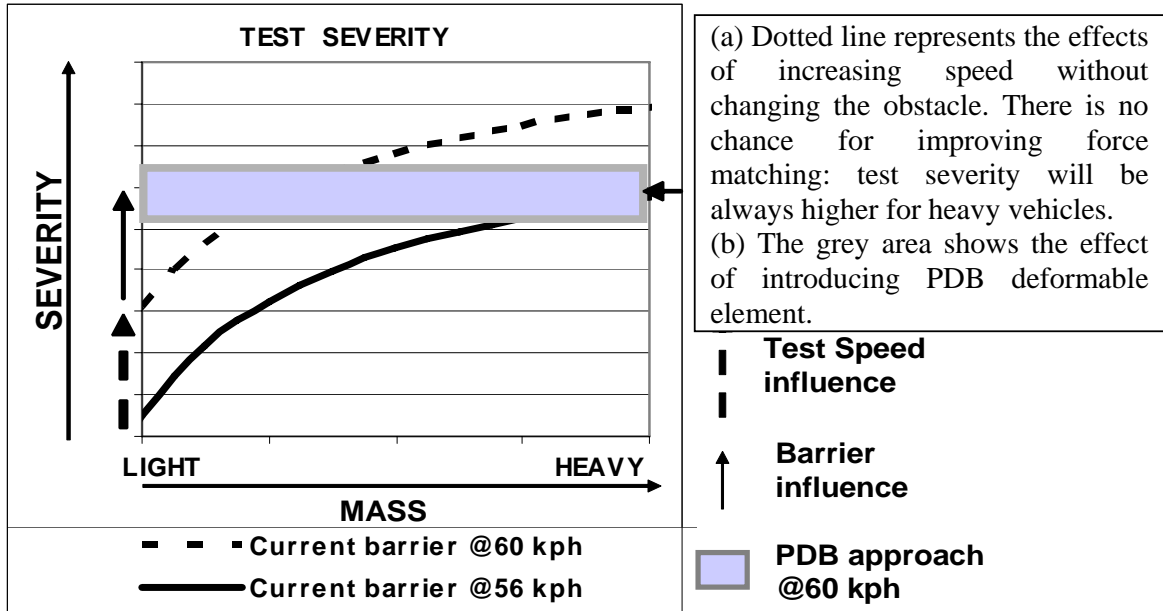

Figure 2: Influence of the test speed and barrier design on the test severity for a vehicle mass.

Vehicle Front force

According to the previous figure 2, light vehicles will be designed with the same self-protection level as the heavy one. The increase of frontal force levels of heavy vehicles will be stopped and the compartment strength of the light vehicle will be reinforced. The concept of force matching will be reachable.

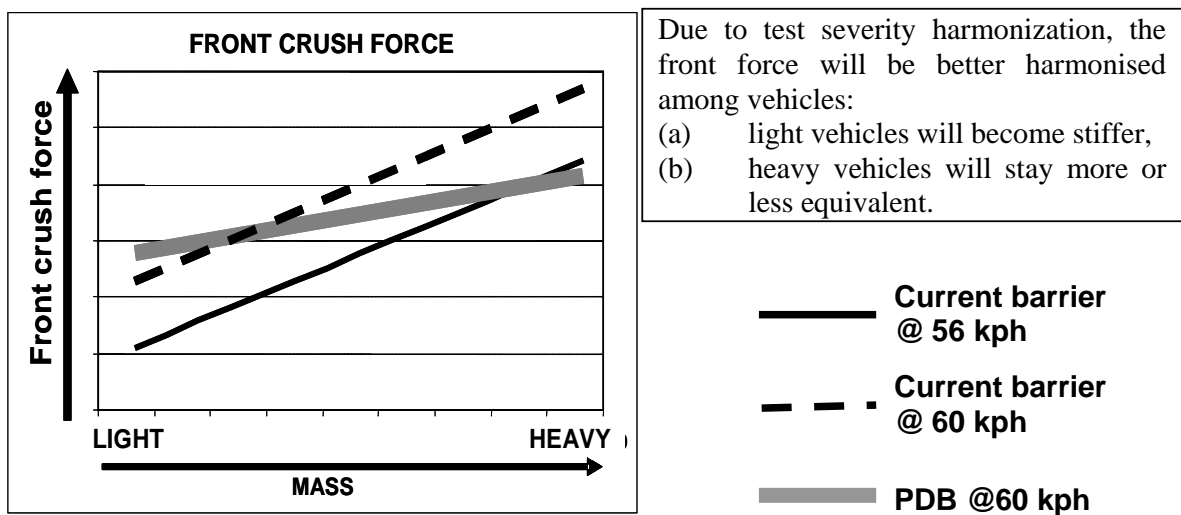

Figure 3: Force level tendency to meet self-protection requirements vs. vehicle mass.

Potential for future compatibility assessment

EEVC WG15 has reviewed the status of current test methods and highly rates the PDB's ability to "assess the frontal crash compatibility of vehicles". The PDB was ranked "the most effective at detecting structural interaction properties of a vehicles and reproducing collapse modes of load paths", the two main parameters identified as important for improving compatibility in terms of partner protection. EEVC WG15 identifies "PDB barrier as one of the most promising tools for future compatibility assessment". According to EEVC WG15 demands, the new requirements introduced with PDB barrier ensure that "frontal force mismatch is not greater than current self protection force level in particular to stop the increase of frontal force levels of heavy vehicles".

Furthermore, the PDB test protocol respects all the requirements, advice and recommendations defined and supplied by EEVC working groups in addition of solving Regulation No. 94 barrier problems.

The PDB test protocol answers general, short term and medium term WG15 road map:

General:

- (a) Proposed test procedures must address both partner and self protection in frontal impacts without decreasing current regulatory self protection levels in other impacts, in particular frontal, and no detrimental consequences for side impact configurations.
- (b) Number of additional test procedures should be kept to a minimum.
- (c) Test procedures should be internationally harmonised.

Short Term:

- (a) Improve structural interaction.
- (b) Control new requirements for passive safety to ensure that frontal force mismatch does not become greater than current self protection force levels in particular to stop the increase of frontal force level of heavy vehicles.
- (c) Control new requirements for passive safety to ensure that compartment strength does not become less than current levels, especially for light vehicles.

Medium Term:

- (a) Improve compartment strength, especially for light vehicles.
- (b) First steps to improve frontal force matching.
- (c) Further improve structural interaction.

Barrier processing, construction and certification

Honeycomb, aluminium and material to process the barrier are commonly used worldwide for reducing the production cost and avoiding processing problem. This barrier must be equivalent without any discrepancy from the origin; four static tests and two dynamic calibration tests are required to validate the conformity of the barrier. The certification is based on the force deflection, the barrier deformation and the stability of the barrier. There is a lack of this kind of validation in the current Regulation No. 94; the introduction of these tests represents a real improvement for car manufacturers and laboratories to guarantee high level of reproducibility.

Others applications and potentials:

Application to N₁ and M₁ vehicles greater than 2,5 tonnes

In 2000, EEVC WG16 considered that "the application of the Directive to M₁ and N₁ vehicles greater than 2.5 tonnes may require a review of the barrier face design". The barrier is ready and more appropriate to N₁ vehicles than the current barrier of Regulation No. 94. This application to N₁ vehicles opens a chance to introduce this class of vehicle in the scope of frontal impact regulation.

Potential for worldwide harmonisation

Due to its progressive stiffness design, the PDB barrier is adapted to all categories of vehicle (light car to large vehicle and M₁ category) and thus the worldwide fleet. A chance for global offset barrier harmonisation is possible.

Potential for possible future applications to Mobile Deformable Barrier (MDB)

In a parallel development program, this deformable element is ready for a possible future Mobile Deformable test used for passenger vehicles and front heavy truck under run protection test. The possible introduction of a MDB with PDB barrier face will not change the front-end design of vehicles and abrupt changes of vehicle designs can be avoided.

Conclusion:

The PDB test protocol incorporates EEVC working groups advice, remarks, comments and short term / mid term road map and remedy problems of current barrier used. The self-protection levels of light vehicles will be improved due to higher test speed, barrier change and overlap without being severe for heavy vehicles. This test procedure will improve force matching and harmonise the different fleets.

References:

Working Groups / Projects / Conference paper:

"Status of Research Work of EEVC WG15" – 41st GRSP/WP.29 - Geneva May 2007.

"Presentation of the status report of EEVC WG15 activities" – 38th GRSP/WP.29 – Geneva December 2005.

"Final Report" – EEVC WG15 (Compatibility and Frontal Impact) – May 2007.

"EEVC Report to EC DG Enterprise Regarding the Revision of the Frontal and Side Impact Directives" – January 2000.

"Development of criteria and standards for vehicle compatibility" – European contract n° BRPR-CT97-0589 – Project n°: BE4049.

"A study to improve the crash compatibility between cars in frontal impact" - European contract n° E3-3 B2702/SI2.318663/2001.

"EEVC Approach to Develop Test Procedure(s) for the Improvement of Crash Compatibility between Passenger Cars paper number"- ESV LYON 2007 paper n° 07-0331- Eberhard Faerber on behalf of EEVC WG 15.

"Status Report of IHRA Compatibility and Frontal Impact Working Group" - paper n° 05-0365- Peter O'Reilly - Chairman of IHRA.

"PDB Barrier Face Evaluation by DSCR and NHTSA's Joint Research Program" - ESV Lyon 2007 Paper 07-0303 - P.Delannoy, T.Martin, S.Meyerson, L.Summers, C.Wiacek.

"Vehicle Passenger Vehicle Crash Test Procedure Developments in the VC-Compat Project" – ESV Washington DC 2005 paper number 05-0008- Robert Thomson - Mervyn Edwards on behalf of the VC-Compat consortium.

"Comparative Evaluation of Frontal Offset Tests to Control Self and Partner Protection" - ESV Washington 2005 Paper 05-0010 - P.Delannoy, T.Martin, P.Castaing.

"New Barrier Test and Assessment Protocol to Control Compatibility » - SAE World Congress 2004 Paper n°04B-160 - P.Delannoy, J.Faure, D.Coulombier, R.Zeitouni, T.Martin.

"EEVC Research in the Field of Improvement of Crash Compatibility Between Passenger Cars" – ESV NAGOYA 2003 Eberhard Faerber on behalf of EEVC WG 15 paper n° 346.

"Compatibility Assessment Proposal Close to Real Life Accidents" - ESV NAGOYA 2003 Paper n° 94 - P.Delannoy, J.Faure

"Compatibility: Causes, Constraints, Improvements and Evaluation Proposal" - SAE World Congress 2002 Paper n° 02AB-194 - P.Delannoy, A.Diboine.

"Structural Front Unit Global Approach" - ESV AMSTERDAM 2001 Paper n°199 - P.Delannoy, A.Diboine.

"Proposal to Improve Compatibility in Head on Collision" - ESV WINDSOR 1998 Paper n° 98-S3-O-05- C.Steyer, P.Delannoy, M.Delhommeau.
