

Proposal for draft amendments to Regulation No 107
(M₂ and M₃ vehicles)

A. BACKGROUND

Supporting the French and German efforts and proposal to formulate requirements, provisions for the driver's compartment of buses, Hungary proposes to add the requirements of driver's seat position related to the steering wheel and the pedals to the requirements of ECE/TRANS/WP.29/GRSG/2007/8.

Hungary underlines the opinion that the comfort of the driver is an essential subject in the bus and coach general safety and supports further efforts in the future to develop the safety and comfort of the driver.

B. PROPOSAL

Annex 3, insert a new paragraph 7.7.15., to read:

"7.7.15. Driver's seat position related to the steering wheel and the pedals

7.7.15.1. The driver's seat, the steering wheel and the gas pedal shall have their basic common position as it is shown on figure 1:

7.7.15.1.1. the vertical position of the driver seat's R point above the floor level of the driver compartment (C=420 mm);

7.7.15.1.2. the vertical position of the centre of the steering wheel related to the driver seat's R point (D=250 mm);

7.7.15.1.3. the horizontal position of the driver seat's R point to the heel point of the gas pedal (A=730 mm);

7.7.15.1.4. the horizontal distance between the driver seat's R point and the centre of the steering wheel (B= 500 mm).

7.7.15.2. The driver seat shall have a minimum range of adjustment:

7.7.15.2.1. in vertical direction ± 50 mm;

7.7.15.2.2. in horizontal direction ± 90 mm.

7.7.15.3. The steering wheel shall have a minimum range of adjustment related to its centre:

7.7.15.3.1. in vertical direction ± 50 mm;

7.7.15.3.2. in horizontal direction ± 35 mm."

C. JUSTIFICATION

The individual drivers have different anthropometric data. Providing comfortable position and working circumstances for all drivers, generally the 5% - 50% - 95% percentile population dimensions are considered (sometimes the 99% also). The driver, sitting in the driver seat has to control the pedals (gas pedal as reference point) by foot and the steering wheel by hands. The adjustment of the driver position is a two steps procedure:

- a) adjust the driver seat to the (gas) pedal;
- b) adjust the steering wheel to the driver seat.

The basic position relates to the 50% "anthropometric driver" and the adjustments consider the 5% and 95% (99%) driver's figures.

Hungary thinks that the further parameters, dimensions should be also regulated in the close future, like:

- the angle of driver seat's seat back and its adjustment
- the angle of the steering wheel's plane
- the angle of the (gas) pedal and its working range
- the free space for the driver feet in the region of the pedals and in resting position.

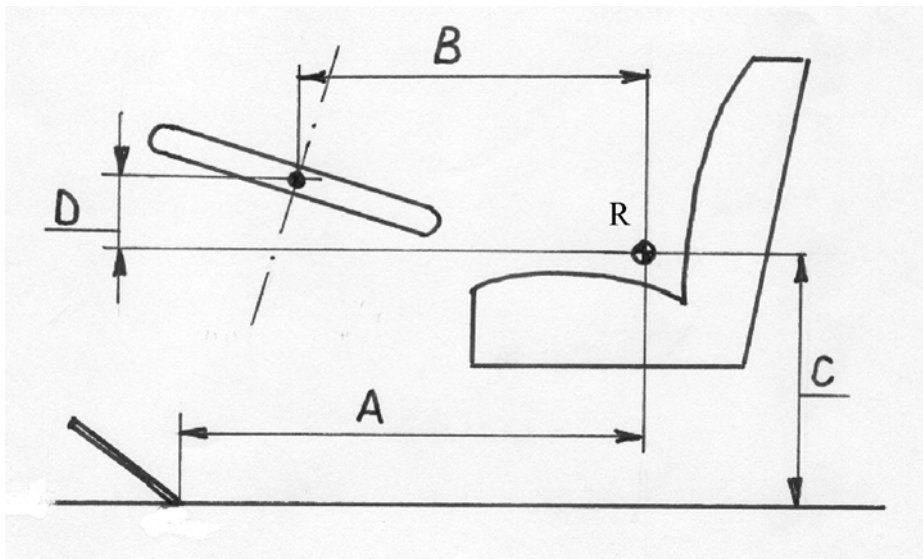

Figure 1
