

Distr.
GENERAL

TRANS/WP.29/GRSP/2002/10
7 March 2002

ENGLISH ONLY

ECONOMIC COMMISSION FOR EUROPE

INLAND TRANSPORT COMMITTEE

World Forum for Harmonization of Vehicle Regulations (WP.29)

Working Party on Passive Safety (GRSP)
(Thirty-first session, 13-17 May 2002,
agenda item 1.7.1.)

PROPOSAL FOR DRAFT AMENDMENTS TO REGULATION No. 44

(Child restraints)

Transmitted by the Expert from the Netherlands

Note: The text reproduced below was prepared by the expert from the Netherlands following the request of GRSP (TRANS/WP.29/GRSP/30, para. 48) for transmitting a consolidated proposal of documents:

- TRANS/WP.29/GRSP/2000/16 from Germany on behalf of the informal group of technical services, with deletion of paragraph. 2.28 because this was again changed in the second German proposal TRANS/WP.29/GRSP/2001/8;
- TRANS/WP.29/GRSP/2001/8 from Germany on behalf of the informal group of technical services;
- Informal document No. 6 from Sweden to introduce a floor pan on the test trolley;
- TRANS/WP.29/2000/15 from the Netherlands to incorporate into the test the rebound movement as a result of an impact; and
- TRANS/WP.29/2001/21 from the Netherlands to improve the registration of the dynamic behaviour.

Doing this compilation some amendments are added; these adding can be recognized as ~~crossed-out~~ (proposed to be removed from the above mentioned documents and/or the original Regulation), or as *italics* (new wording in addition to above mentioned documents and/or the original Regulation).

Note: This document is distributed to the Experts on Passive Safety only.

GE.02-

Insert a new par. 2.11.1., to read:

"2.11.1. "support leg" means a ~~rigid~~ permanent attachment to a child restraint creating a compressive load path between the child restraint and a vehicle structure *in order to by-pass seat cushion effects during deceleration*; a support leg may be adjustable."

Paragraph 2.14.1., amend to read:

2.14.1 " ... under Regulation No. 14. This includes the *trolley floor panel* ~~pan~~ *as described in Annex 6* or other structural features of ~~a~~ *the specific* vehicle(s) when loaded by a support leg."

Paragraph 2.23.2., correct the word "look" to read "lock"

~~Insert a new paragraph 2.28., to read:~~

~~"2.28. Adult safety belt webbing guide~~

~~A device through which the adult belt passes for its correct routing and that presents a resistance to webbing movement of less than 2 N when tested as installed for use in annex 21.~~

Insert a new paragraph 2.28., to read:

"2.28. "Adult safety-belt webbing guide" means a device through which the adult belt passes for its correct routing, that allows free webbing movement."

Paragraph 4.4., should be deleted.

Paragraphs 4.5. to 4.8. (former), renumber as paragraphs 4.4. to 4.7.

Insert a new par. 6.1.3.5., to read:

"6.1.3.5. *Child restraints utilising a support leg shall only be approved under the "semi-universal" or the "specific vehicle" category. ~~and the requirements of annex 11 to this Regulation shall be applied.~~ The manufacturer of the child restraint system shall take into account the needs of the support leg for their correct functioning in each vehicle and provide this information.*

Insert a new paragraph 7.1.2.2., to read:

"7.1.2.2. In the case of child restraint systems with permanent mechanically attached adjustable head support devices, in which the height of either the adult safety-belt or of the child harness is directly controlled by the adjustable head support, it is not necessary to demand energy absorbing material in areas as defined in annex 18, which are not contactable by the manikin's head, i.e. behind the head support."

Paragraph 7.1.4.1.3., correct the word "preformed" to read "performed".

Insert a new paragraph 7.1.4.1.9., to read:

"7.1.4.1.9. *In the case of a child restraint making use of an ISOFIX anchorage system and an top tether strap or an other anti-rotation device, the dynamic test shall be carried out under two conditions:*

7.1.4.1.9.1. *with the top tether strap or the anti-rotation device in function, and*

7.1.4.1.9.2. *without the top tether strap or the anti-rotation device in function, in which case only par. 7.1.4.1.4. has to be fulfilled."*

~~Paragraph 7.1.4.2.1., amend to read (the cursive text has been added):~~

~~"7.1.4.2.1. The resultant chest acceleration shall not exceed 55 g except during periods whose sum does not exceed 3 ms; this shall be judged up to the moment that the manikin has come to a definitive standstill."~~

~~Paragraph 7.1.4.2.2., amend to read (the cursive text has been added):~~

~~"7.1.4.2.2. The vertical component of the acceleration from the abdomen towards the head shall not exceed 30 g except during periods whose sum does not exceed 3 ms; this shall be judged up to the moment that the manikin has come to a definitive standstill."~~

Paragraph 7.1.4.4.1.1., amend to read (the cursive text has been added):

"7.1.4.4.1.1. Forward facing child restraints: the head of the manikin shall not pass beyond the planes BA and DA as defined in Figure 1 below. This shall be judged up to 300 ms or the moment that the manikin has come to a definitive standstill *whatever occurs first*.

Dimensions in mm

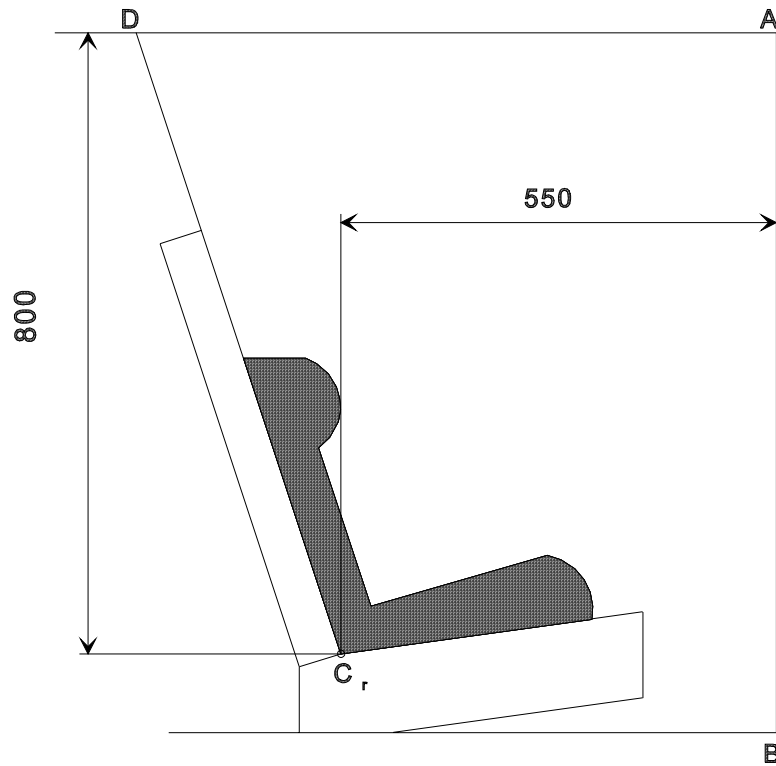

Figure 1
Arrangement for testing a forward-facing device"

Paragraph 7.1.4.4.1.2.1., amend to read:

"7.1.4.4.1.2.1. Child restraints supported by dashboard: the head of the manikin shall not pass beyond the planes AD and DCr, as defined in Figure 2 below. This shall be judged up to 300 ms or the moment that the manikin has come to a definitive standstill whatever occurs first.

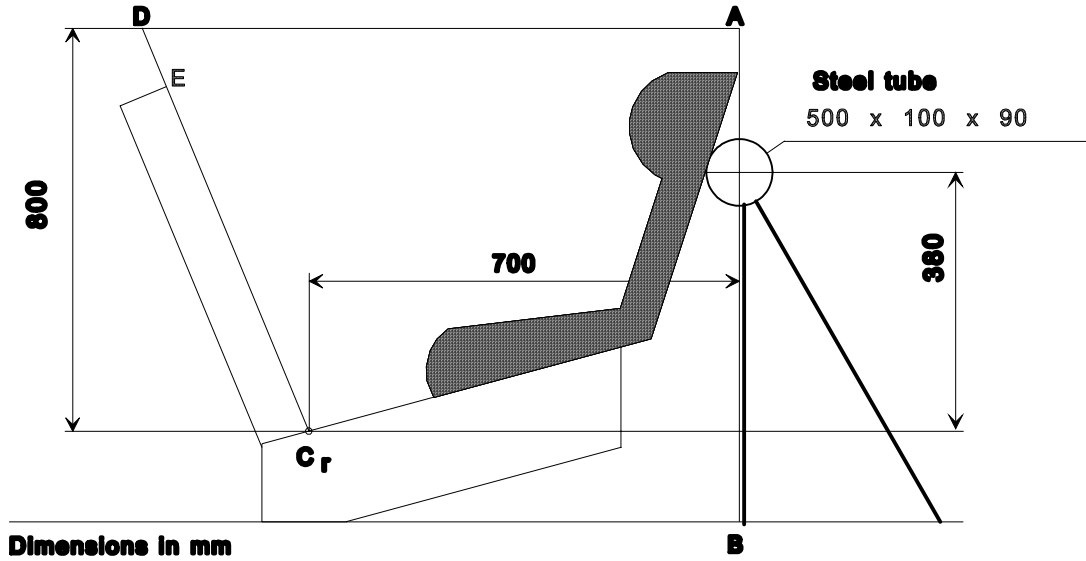

Figure 2:
Arrangement for testing
a rearward-facing device

"

Paragraph 7.1.4.4.1.2.1., insert the reference to the plane "AB" before to the reference to the plane "AD".

Paragraph 7.1.4.4.1.2.2., amend to read:

"7.1.4.4.1.2.2. Child restraints in group 0 not supported by the dashboard, and carrycots: the head of the manikin shall not pass the planes AB, AD and DE as shown in Figure 3 below. This shall be judged up to 300 ms or the moment that the manikin has come to a definitive standstill *whatever occurs first*.

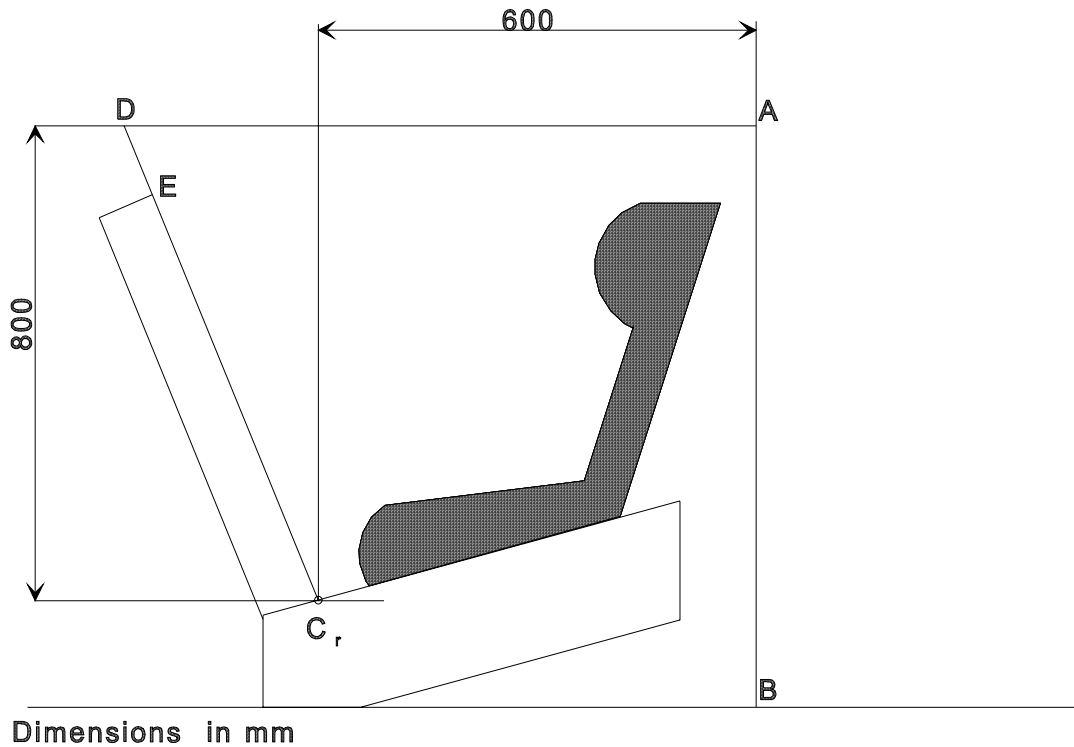

Figure 3

Arrangement for testing child restraint devices group 0,
not supported by the dashboard"

Paragraph 7.1.4.4.1.2.3., amend to read:

"7.1.4.4.1.2.3. Child restraints other than group 0 not supported by the dashboard:

The head of the manikin shall not pass the planes FD, FG and DE, as shown in Figure 4 below. This shall be judged up to 300 ms or the moment that the manikin has come to a definitive standstill *whatever occurs first*.
In the case "

Paragraphs 8.4. to 8.4.2., amend to read:

"8.4. Registration of dynamic behaviour

8.4.1. In order to determine the behaviour of the manikin and its displacements, all dynamic tests shall be registered according to the following conditions:

8.4.1.1. Filming and recording conditions:

- the frequency shall be at least 1000 frames per second;
- the test shall be recorded on cine film, video or digital data carrier;

8.4.1.2. Set up conditions of cameras:

cameras offering side view and where applicable top view shall be used, taking account of the following:

- the cameras optical axis has to be perpendicular to the direction of travel of the sled with an accuracy of ± 2.5 degrees;
- an out of plane motion 6/ shall not lead to a photogrammetric underestimation of displacement measurements. Therefore the set up condition shall be such that out of plane motion is always directed to the side view cameras;
- an offset of the manikin 7/ shall not lead to photogrammetric underestimation of displacement measurements.

8.4.1.3. Performance of the registration process:

- in order to evaluate the performance of the filming and recording media a distortion index shall be assessed according to ISO 8721, edition 1987; during the static assessment the distortion index shall not exceed the value of 1 per cent;
- in case of cameras that run with the sled, the camera support shall have sufficient rigidity. Therefore it shall be proven by means of a dynamic assessment according a curve within the hatched area shown in annex 7 - appendix 1 and passing through a maximum of $26\text{ G} \pm 1\text{ G}$ that a change in accuracy does not lead to exceeding the limits that count for the static assessment above;

8.4.2. Analysing recordings:

- suitable calibration markings shall be mounted firmly on the trolley or in the vehicle structure so that the displacement of the manikin can be determined. The reference length used for scaling shall be determined with an accuracy of ± 2.5 mm, the reference length shall be at least 1000 mm."

6/ In case of three point belts the chosen shoulder attachment (left or right) will lead to a rotation of the upper torso and head towards the belted shoulder.

7/ Paragraph 8.1.3.6.3.3. allows positioning up to 80 mm out of the centre.

Paragraph 9.1., amend to read:

- "9.1. The test report shall record the results of all tests and measurements (including the deceleration curve and the registration of the time (in msec) when the head of the manikin reaches its maximum displacement during the performance of the dynamic test), and the trolley speeds, the place occupied by the buckle during the tests, if it can be varied, and any failure of breakage.

Paragraph 11.4., amend to read */:

- "11.4. The competent authority which has granted type-approval shall at optional times, if legally possible, verify the conformity control methods and results applicable to each production unit."

*/ Note by the secretariat: The proposed text contradicts paragraph 2.2. of appendix 2 to the 1958 Agreement (E/ECE/324, E/ECE/TRANS/505 Rev.2)

Annex 6,

Paragraph 1.1., amend to read:

- "1.1. For tests on child restraint systems, the trolley, carrying the For tests on child restraint systems in the vehicle specific category the trolley with the"

Insert new paragraphs 3.3 to 3.3.1.5., to read:

- 3.3 Trolley floor pan
- 3.3.1. The floor pan of the trolley shall be constructed of a flat sheet of metal of uniform thickness and material , see figure 2 of appendix 3 to this annex.
- 3.3.1.1. The floor pan shall be rigidly intermittent welded or bolted to the corresponding trolley structure.
- 3.3.1.2. The floor pan shall be designed so that the surface hardness should not be below 120 HB, according to EN ISO 6506-1:1999.
- 3.3.1.3. The floor pan shall withstand an applied vertical concentrated load of 5 kN without causing a vertical movement greater than 2 mm referring to Cr and without any permanent deformation occurring.
- 3.3.1.4. The floor pan shall have a surface roughness not exceeding Ra 6,3 according to ISO 4287:1997.
- 3.3.1.5. The floor pan shall be designed so that no permanent deformation is occurring after a dynamic test of a child restraint system, according to this Regulation.

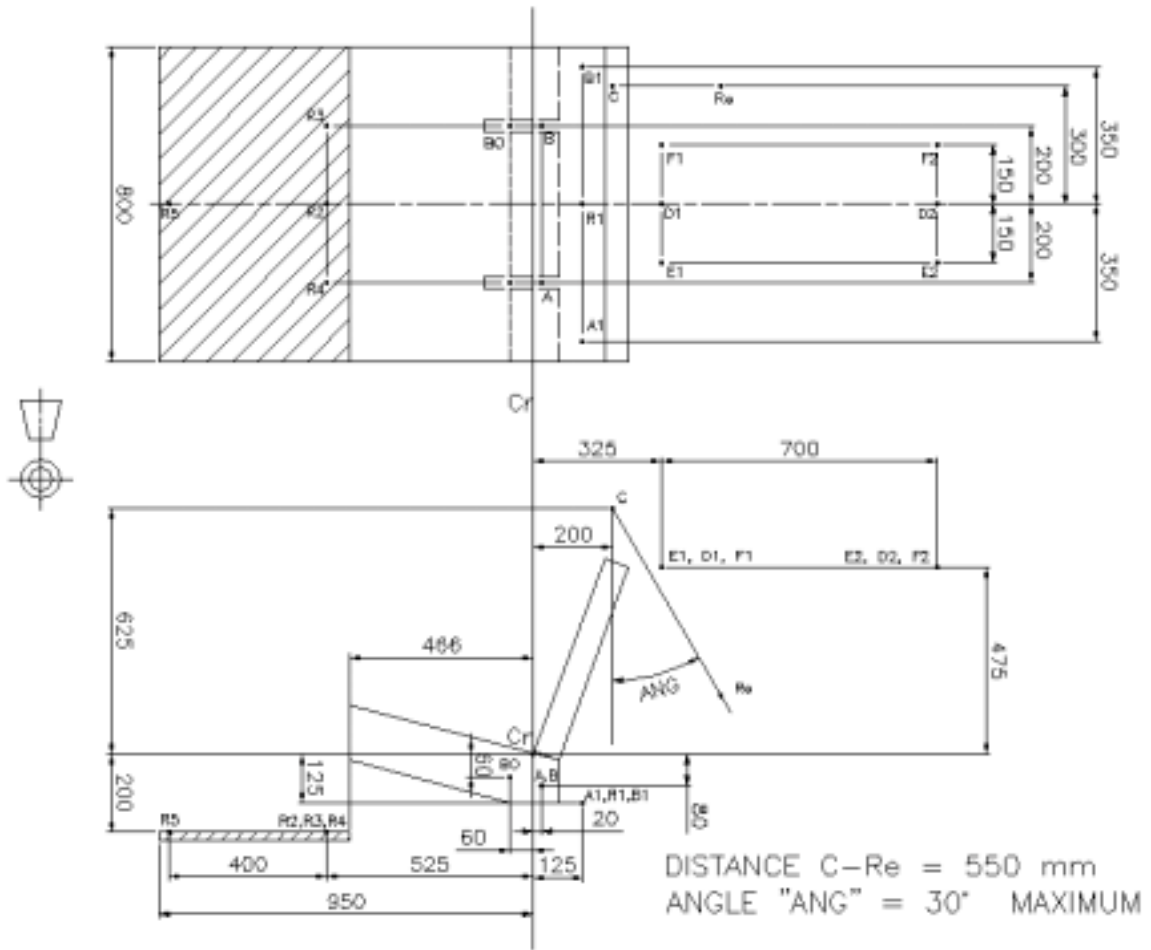

Figure 2

FLOOR AREA IS HATCHED

Annex 6, appendix 3,

Insert a new paragraph 9., to read:

- "9. In the case of child restraints utilising a support leg, the technical service shall select the anchorages to be used according to paragraphs 2., 3., 4. or 5. above and with the support leg adjusted as specified in paragraph 7.1.4.1.9."

Annex 8, appendix 3, paragraph 3.2.1., table 2, insert the missing row 13, to read:

13	neck width	65
----	------------	----

Annex 18, paragraph 1., amend to read:

" of the child seat. In the case of carry cot devices the whole inner surfaces shall be covered with material complying with annex 17; this material has to fulfil its purpose together with the inner side structure; the technical service may assess this aspect with further tests."

* * *

B. JUSTIFICATION

Ref. paragraphs 2.11.1., 2.14.1. 6.1.3.5., 7.1.4.1.9., annex 6, paragraph 9.

The support leg at child restraints is a new feature of technical development; it needs to be specified for testing because it has already been submitted for approval testing at technical services.

Ref. paragraph 2.28.

The definition of a webbing guide is necessary for such mass groups where a lock-off device is not prescribed and where a webbing guide is only used which shall not be submitted to the lock-off test requirements. This revised proposal omits any test qualification because the upcoming lower limit of 1 N in Regulation No. 16 (adult safety-belts) for webbing roll-off force cannot be tested properly at such a webbing guide.

Ref. paragraph 4.4.

The new warning label inserted into the Regulation by Supplement 2 to the 03 series of amendments duplicates those warning labels. As it is the more stringent one, the less stringent old warning label of paragraph 4.4. seems to be superfluous.

Ref. paragraph 7.1.2.2.

In the described cases an unnecessary duplication of energy absorbing material shall be prevented.

Ref. paras. 7.1.4.2.1. to 7.1.4.4.1.2.3.

It has been noted that with regard to the dynamic behaviour of the manikin it is a (common) practice that Technical Services only judge the first movement as a result of the impact.

However, it is our opinion that, with regard to the dynamic behaviour, not only the first movement has to be judged as a result of the impact, but also the movement afterwards, being the result of the rebound.

The proposal takes the above into consideration, in order to limit dangers of a.o. excessive rotational acceleration.

Ref. paragraph 8.4. to 8.4.1.3. and 9.1.

The prescribed camera conditions set out are meant to facilitate a more consistent way of registration head displacements, which will become of even more importance because of new technologies of child restraint systems being introduced.

Ref. annex 6

This definition will set a clear and legible standard for the design of the trolley floor pan, which will enable manufacturers, test facilities and certification authorities to use the same parameters in the process of designing, testing and certification of child restraint systems.

The floor pan will improve the trolley since it will more accurately simulate an actual vehicle structure.

Ref. annex 18, paragraph 1.

The respective specification in Supplement 3 to the 03 series of amendments to this Regulation took into account neither the rear impact nor the two orientation possibilities of a child in a carrycot. So the whole inner side surface was found to need energy absorbing material.

Ref. paragraph 11.4.

The supervision of the testing for conformity of production varies from country to country. A stringent supervision seems to be necessary for all countries applying Regulation No. 44.
