



**Economic and Social
Council**

Distr.
GENERAL

TRANS/WP.29/2002/23
20 December 2001

Original: ENGLISH

ECONOMIC COMMISSION FOR EUROPE

INLAND TRANSPORT COMMITTEE

World Forum for Harmonization of Vehicle Regulations (WP.29)
(One-hundred-and-twenty-sixth session,
12-15 March 2002, agenda item 4.3.5.)

PROPOSAL FOR A NEW DRAFT REGULATION:

UNIFORM TECHNICAL PRESCRIPTIONS CONCERNING THE BURNING BEHAVIOUR
OF MATERIALS USED IN THE INTERIOR CONSTRUCTION
OF CERTAIN CATEGORIES OF MOTOR VEHICLES

Transmitted by the Working Party on General Safety Provisions (GRSG)

Note: The text reproduced below was adopted by GRSG at its eighty-first session, and is transmitted to WP.29 and to AC.1 for consideration. It is based on document TRANS/WP.29/GRSG/1999/23/Rev.1, as amended (TRANS/WP.29/GRSG/60, para. 22).

This document is a working document circulated for discussion and comments. The use of this document for other purposes is the entire responsibility of the user. Documents are also available via the INTERNET: <http://www.unece.org/trans/main/welcwp29.htm>

Regulation No. xxxx

UNIFORM TECHNICAL PRESCRIPTIONS CONCERNING THE BURNING BEHAVIOUR OF MATERIALS
USED IN THE INTERIOR CONSTRUCTION OF CERTAIN CATEGORIES
OF MOTOR VEHICLES

CONTENTS	Page
1. Scope	3
2. Definitions	3
3. Application for approval	4
4. Approval	4
5. Part I - Definitions - Specifications	6
6. Part II - Definitions - Specifications	6
7. Modification of the type and extension of approval	8
8. Conformity of production	9
9. Penalties for non-conformity of production	9
10. Production definitely discontinued	9
11. Names and addresses of technical services responsible for conducting approval tests and of administrative departments	10
ANNEXES	
<u>Annex 1</u> - Information document for vehicle	11
<u>Annex 2</u> - Information document for component	12
<u>Annex 3</u> - Communication concerning approval of a vehicle type	13
<u>Annex 4</u> - Communication concerning approval of a component type	15
<u>Annex 5</u> - Arrangements of approval marks	17
<u>Annex 6</u> - Test to determine the horizontal burning rate of materials	19
<u>Annex 7</u> - Test to determine the melting behaviour of materials	25
<u>Annex 8</u> - Test to determine the vertical burning rate of materials	29

1. SCOPE

- 1.1. This Regulation applies to the burning behaviour (ignitibility, burning rate and melting behaviour) of interior materials used in vehicles of categories M3, Classes II and III 1/, carrying more than 22 passengers, not being designed for standing passengers and urban use (city buses)

Type approvals are granted according to:

- 1.2. Part I - Approval of a vehicle type with regard to the burning behaviour of the interior components used in the passenger compartment
- 1.3. Part II - Approval of a component (materials, seats, curtains, separation walls, etc.) with regard to its burning behaviour.

2. DEFINITIONS: General

- 2.1. "Manufacturer" means the person or body who is responsible to the approval authority for all aspects of the type approval process and for ensuring conformity of production. It is not essential that the person or body is directly involved in all stages of the construction of the vehicle or component which is the subject of the approval process.

- 2.2. "Passenger compartment" means the space for occupants' accommodation including bar, kitchen, toilet, etc.), bounded by:

- the roof,
- the floor,
- the side walls,
- the doors,
- the outside glazing,
- the rear compartment bulkhead, or the plane of the rear seat,
- back support,
- at the driver's side of the longitudinal vertical median plane of the vehicle, the vertical transversal plane through the driver's R-point as defined in Regulation No. 17.
- at the opposite side of the longitudinal vertical median plane of the vehicle, the front bulkhead.

- 2.3. "Production materials" means products, in the form of bulk materials (e.g. rolls of upholstery) or preformed components, supplied to a manufacturer for incorporation in a vehicle type approved under this Regulation, or to a workshop for use in the business of vehicle maintenance or repair.

- "2.4. "Seat" means a structure which may or may not be integral with the vehicle structure, complete with trim, intended to seat one adult person. The term covers both an individual seat or part of a bench seat intended to seat one adult person.

1/ As defined in the Consolidated Resolution on the Construction of Vehicles (R.E.3), annex 7 (documents TRANS/WP.29/78/Rev.1 and Amend.2).

2.5. "Group of seats" means either a bench-type seat, or seats which are separate but side by side (i.e. with the foremost anchorages of one seat in line with or forward of the rearmost anchorages and in line with or behind the foremost anchorages of another seat) and which accommodate one or more seated adult persons.

2.6. "Bench seat" means a structure complete with trim, intended to seat more than one adult person.

3. APPLICATION FOR APPROVAL

3.1. The application for approval of a vehicle or component type with regard to this Regulation shall be submitted by the manufacturer.

3.2.1. It shall be accompanied by an information document conforming to the model shown in annex 1 or in annex 2.

3.3. The following must be submitted to the technical service responsible for conducting the type approval tests:

3.3.1. In the case of approval of a vehicle: a vehicle representative of the type to be approved.

3.3.2. in the case of interior components already type approved: a list of the type approval numbers and maker's type designations of the parts concerned, shall be enclosed in the application for the vehicle type approval;

3.3.3. in the case of interior components without ECE type approval:

3.3.3.1. samples, the number of which is specified in annexes 6 to 8, of the components used in the vehicles, which are representative of the type to be approved;

3.3.3.2. Furthermore, one sample shall be submitted to the technical service for future reference purposes;

3.3.3.3. For devices such as seats, curtains, separation walls, etc., the samples specified in paragraph 3.3.3.1. plus one complete device as mentioned above.

3.3.3.4. The samples shall be clearly and indelibly marked with the applicant's trade name or mark and the type designation;

4. APPROVAL

4.1. If the type submitted for approval to this Regulation meets the requirements of the relevant part(s) of this Regulation, approval of that type shall be granted.

4.2. An approval number shall be assigned to each type approved. Its first two digits (at present 00, corresponding to the Regulation in its original form) shall indicate the series of amendments incorporating the most recent [major] technical amendments made to the Regulation at the time of issue of the approval. The same Contracting Party shall not assign the same number to another type of vehicle or component as defined in this Regulation.

4.3. Notice of approval or of extension of approval of a type pursuant to this Regulation shall be communicated to the Contracting Parties to the Agreement applying this Regulation, by means of one of the

forms conforming to the models in annexes 3 or 4, as appropriate, to this Regulation.

- 4.4. There shall be affixed, conspicuously and in a readily accessible location specified on the approval form, to every vehicle conforming to a type approved under this Regulation, to the packaging of every material (see paragraph 4.4.2.3.) conforming to a type approved under this Regulation and to every component supplied separately conforming to a type approved under this Regulation, an international approval mark consisting of:
- 4.4.1. A circle surrounding the letter "E" followed by the distinguishing number of the country which has granted component type approval 2/,
- 4.4.2. in the vicinity of the circle:
- 4.4.2.1. symbols indicating the direction for which the burning rate of the component has been determined:
- ↔ for the horizontal direction (annex 6),
 - ↑ for the vertical direction (annex 8),
 - ↓ for the horizontal and vertical direction (annexes 6 and 8);
- 4.4.2.2. the symbol "V" indicating that the component has been approved according to its melting behaviour (annex 7) and/or the symbol "CD" indicating that the component has been approved as a complete device, such as seats, separation walls, luggage racks, etc.
- 4.4.2.3. Production materials do not need to be individually marked. However, the packaging with which they are supplied must be clearly marked with the approval mark described above.

2/ 1 for Germany, 2 for France, 3 for Italy, 4 for the Netherlands, 5 for Sweden, 6 for Belgium, 7 for Hungary, 8 for the Czech Republic, 9 for Spain, 10 for Yugoslavia, 11 for the United Kingdom, 12 for Austria, 13 for Luxembourg, 14 for Switzerland, 15 (vacant), 16 for Norway, 17 for Finland, 18 for Denmark, 19 for Romania, 20 for Poland, 21 for Portugal, 22 for the Russian Federation, 23 for Greece, 24 for Ireland, 25 for Croatia, 26 for Slovenia, 27 for Slovakia, 28 for Belarus, 29 for Estonia, 30 (vacant), 31 for Bosnia and Herzegovina, 32 for Latvia, 33 (vacant), 34 for Bulgaria, 35 - 36 (vacant), 37 for Turkey, 38 - 39 (vacant), 40 for The former Yugoslav Republic of Macedonia, 41 (vacant), 42 for the European Community (Approvals are granted by its Member States using their respective ECE symbol), 43 for Japan, 44 (vacant), 46 for Australia, 46 for Ukraine and 47 for South Africa. Subsequent numbers shall be assigned to other countries in the chronological order in which they ratify or accede to the Agreement concerning the Adoption of Uniform Technical Prescriptions for Wheeled Vehicles, Equipment and Parts which can be fitted and/or be used on wheeled vehicles and the Conditions for Reciprocal Recognition of Approvals granted on the basis of these Prescriptions, and the numbers thus assigned shall be communicated by the Secretary-General of the United Nations to the Contracting Parties to the Agreement.

- 4.4.2.4. If separately marked, large components, for example seats, comprising of more than one piece of approved material, may have a single mark indicating the approval number(s) of the material(s) used.
- 4.4.3. If a type conforms to a type approved, under one or more other Regulations annexed to the Agreement, in the country which has granted approval under this Regulation, the symbol prescribed in paragraph 4.4.1. need not be repeated; in such a case, the Regulation under which approval has been granted in the country which has granted approval under this Regulation shall be placed in vertical columns to the right of the symbol prescribed in paragraph 4.4.1.
- 4.4.4. The approval mark shall be clearly legible and be indelible.
- 4.4.5. In the case of a vehicle, the approval mark shall be placed close to or on the vehicle data plate affixed by the manufacturer.
- 4.4.6. Annex 5 to this Regulation gives examples of arrangements of approval marks.
5. PART I: APPROVAL OF A VEHICLE TYPE WITH REGARD TO THE BURNING BEHAVIOUR OF THE INTERIOR COMPONENTS USED IN THE PASSENGER COMPARTMENT
- 5.1. Definition
- For the purpose of Part I of this Regulation,
- 5.1.1. "Vehicle type" means vehicles that do not differ in such essential respects as the manufacturer's type designation
- 5.2. Specifications
- 5.2.1. The interior materials of the passenger compartment used in the vehicle to be type approved shall meet the requirements of Part II of this Regulation.
- 5.2.2. The materials and/or equipment used in the passenger compartment and/or in devices approved as components shall be so installed as to minimize the risk of flame development and flame propagation.
- 5.2.3. Such interior materials and/or equipment shall only be installed in accordance with their intended purposes and the test(s) which they have undergone (see paragraphs 6.2.1., 6.2.2. and 6.2.3.), especially in relation to their burning and melting behaviour (horizontal/vertical direction).
- 5.2.4. Any adhesive agent used to affix the interior material to its supporting structure shall not, as far as possible, exacerbate the burning behaviour of the material.
6. PART II: APPROVAL OF A COMPONENT WITH REGARD TO ITS BURNING BEHAVIOUR
- 6.1. Definitions
- For the purpose of Part II of this Regulation,

- 6.1.1. "Type of a component" means components which do not differ in such essential respects as:
- 6.1.1.1. the manufacturer's type designation
 - 6.1.1.2. the intended use (seat upholstery, roof lining, etc.),
 - 6.1.1.3. the base material(s) (e. g. wool, plastic, rubber, blended materials),
 - 6.1.1.4. the number of layers in the case of composite materials, and
 - 6.1.1.5. other characteristics in so far as they have an appreciable effect on the performance prescribed in this Regulation.
- 6.1.2. "Burning rate" means the quotient of the burnt distance measured according to annex 6 and/or annex 8 to this Regulation and the time taken to burn this distance. It is expressed in millimetres per minute.
- 6.1.3. "Composite material" means a material composed of several layers of similar or different materials intimately held together at their surfaces by cementing, bonding, cladding, welding, etc. When different materials are connected together intermittently (for example, by sewing, high-frequency welding, riveting), such materials shall not be considered as composite materials.
- 6.1.4. "Exposed face" means the side of a material which is facing towards the passenger compartment when the material is mounted in the vehicle.
- 6.1.5. "Upholstery" means the combination of interior padding and surface finish material which together constitute the cushioning of the seat frame.
- 6.1.6. "Interior lining(s)" means material(s) that (together) constitute(s) the surface finish and substrate of a roof, wall or floor.
- 6.2. Specifications
- 6.2.1. The following materials shall undergo the test described in annex 6 to this Regulation:
- (a) material(s) used for the upholstery of any seat and its accessories (including the driver's seat),
 - (b) material(s) used for the interior lining of the roof,
 - (c) material(s) used for the interior lining of the side and rear walls, including separation walls,
 - (d) material(s) with thermal and/or acoustic function,
 - (e) material(s) used for the interior lining of the floor,
 - (f) material(s) used for the interior lining of luggage-racks, heating and ventilation pipes,

(g) material(s) used for the light fittings

The result of the test shall be considered satisfactory if, taking the worst test results into account, the horizontal burning rate is not more than 100 mm/minute or if the flame extinguishes before reaching the last measuring point.

6.2.2. The following materials shall undergo the test described in annex 7 to this Regulation:

(a) material(s) used for the interior lining of the roof,

(b) material(s) used for the interior lining of the luggage-racks, heating and ventilation pipes situated in the roof,

(c) material(s) used for the lights situated in the luggage-racks and/or roof.

The result of the test shall be considered satisfactory if, taking the worst test results into account, no drop is formed which ignites the cotton wool.

6.2.3. The materials used for the curtains and blinds (and/or other hanging materials) shall undergo the test described in annex 8.

The result of the test shall be considered satisfactory if, taking the worst test results into account, the vertical burning rate is not more than 100 mm/minute.

6.2.4. Materials which are not required to undergo the tests described in annexes 6 to 8 are:

6.2.4.1. parts made of metal or glass;

6.2.4.2. each individual seat accessory with a mass of non-metallic material less than 200 g. If the total mass of these accessories exceeds 400 g of non-metallic material per seat, then each material must be tested;

6.2.4.3. elements of which the surface area or the volume does not exceed respectively:

6.2.4.3.1. 100 cm² or 40 cm³ for the elements which are connected to an individual seating place;

6.2.4.3.2. 300 cm² or 120 cm³ per seat row and, at a maximum, per linear metre of the interior of the passenger compartment for these elements which are distributed in the vehicle and which are not connected to an individual seating place;

6.2.4.4. electric cables;

6.2.4.5. elements for which it is not possible to extract a sample in the prescribed dimensions as specified in paragraph 3.1. of annex 6, paragraph 3. of annex 7, and paragraph 3.1. of annex 8

7. MODIFICATION OF THE TYPE AND EXTENSION OF APPROVAL

7.1. Every modification of a vehicle or component type with regard to this Regulation shall be notified to the administrative department

which approved the vehicle or the component type. The department may then either:

- 7.1.1. Consider that the modifications made are unlikely to have an appreciable adverse effect and that in any case vehicles or components still comply with the requirements, or
- 7.1.2. Require a further test report from the technical service responsible for conducting the tests.
- 7.2. Confirmation or refusal of approval, specifying the alterations shall be communicated by the procedure specified in paragraph 4.3. above to the Contracting Parties to the Agreement applying this Regulation.
- 7.3. The competent authority issuing the extension of approval shall assign a serial number to each communication form drawn up for such an extension and inform thereof the other Parties to the 1958 Agreement applying this Regulation by means of a communication form conforming to the model in annex 3 or annex 4 to this Regulation.

8. CONFORMITY OF PRODUCTION

The conformity of production procedures shall comply with those set out in the Agreement, Appendix 2 (E/ECE/324-E/ECE/TRANS/505/Rev.2), with the following requirements:

- 8.1. Vehicles/components approved under this Regulation shall be so manufactured as to conform to the type approved by meeting the requirements of the relevant part(s) of this Regulation.
- 8.2. The authority that has granted type approval may at any time verify the conformity control methods applied in each production facility. The normal frequency of these verifications shall be one every two years.

9. PENALTIES FOR NON-CONFORMITY OF PRODUCTION

- 9.1. The approval granted in respect of a vehicle/component type pursuant to this Regulation may be withdrawn if the requirements set forth above are not met.
- 9.2. If a Contracting Party to the Agreement applying this Regulation withdraws an approval it has previously granted, it shall forthwith so notify the other Contracting Parties applying this Regulation by means of a communication form conforming to the models in annex 3 or annex 4 to this Regulation.

10. PRODUCTION DEFINITELY DISCONTINUED

If the holder of the approval completely ceases to manufacture a vehicle type approved in accordance with this Regulation, he shall so inform the authority which granted the approval. Upon receiving the relevant communication that authority shall inform thereof the other Parties to the 1958 Agreement applying this Regulation by means of a communication form conforming to the model in annex 3 or annex 4 to this Regulation.

11. NAMES AND ADDRESSES OF TECHNICAL SERVICES RESPONSIBLE FOR CONDUCTING APPROVAL TESTS AND OF ADMINISTRATIVE DEPARTMENTS

The Parties to the 1958 Agreement applying this Regulation shall communicate to the United Nations Secretariat the names and addresses of the technical services responsible for conducting approval tests and of the administrative departments which grant approval and to which forms certifying approval or extension or refusal or withdrawal of approval, issued in other countries, are to be sent.

Annex 1

INFORMATION DOCUMENT

(in accordance with paragraph 3.2 of this Regulation relating to the ECE Type Approval of a vehicle with regard to the burning behaviour of the interior components used in the passenger compartment)

If the systems, components or separate technical units have electronic controls, information concerning their performance must be supplied

1. GENERAL
 - 1.1. Make (trade name of manufacturer):
 - 1.2. Type and general commercial description(s):
 - 1.3. Means of identification of type, if marked on the vehicle:
 - 1.4. Location of that marking:
 - 1.5. Category of vehicle: 1/
 - 1.6. Name and address of manufacturer:
 - 1.7. Address(es) of assembly plant(s):
2. GENERAL CONSTRUCTION CHARACTERISTICS OF THE VEHICLE
 - 2.1. Photographs and/or drawings of a representative vehicle:
3. BODYWORK
 - Interior fittings
 - 3.1. Seats
 - 3.1.1. Number:
 - 3.2. Burning behaviour of materials used in the interior construction of the vehicle
 - 3.2.1. Material(s) used for the interior lining of the roof
 - 3.2.1.1. Component type-approval number(s):
 - 3.2.2. Material(s) used for the rear and side walls
 - 3.2.2.1. Component type-approval number(s):
 - 3.2.3. Material(s) used for the floor
 - 3.2.3.1. Component type-approval number(s):
 - 3.2.4. Material(s) used for the upholstery of the seats
 - 3.2.4.1. Component type-approval number(s):
 - 3.2.5. Material(s) used for heating and ventilation pipes
 - 3.2.5.1. Component type-approval number(s):
 - 3.2.6. Material(s) used for luggage racks
 - 3.2.6.1. Component type-approval number(s):
 - 3.2.7. Material(s) used for other purposes
 - 3.2.7.1. Intended purposes:
 - 3.2.7.2. Component type-approval number(s):
 - 3.2.8. Components approved as complete devices (seats, separation walls, luggage racks, etc.)
 - 3.2.8.1. Component type-approval number(s):

1/ As defined in the Consolidated Resolution on the Constuction of Vehicles (R.E.3.), annex 7 (documents TRANS/WP.29/78/Rev.1 and Amend.2)

Annex 2

INFORMATION DOCUMENT

(in accordance with paragraph 3.2 of the Regulation relating to the ECE Type approval of a component with regard to its burning behaviour)

If the systems, components or separate technical units have electronic controls, information concerning their performance must be supplied

1. GENERAL
- 1.1. Make (trade name of manufacturer):
- 1.2. Type and general commercial description(s):
- 1.3. Name and address of manufacturer:
- 1.4. In the case of components and separate technical units, location and method of affixing of the EEC approval mark:
- 1.5. Address(es) of assembly plant(s):

2. INTERIOR MATERIALS
- 2.1. Material(s) used for:
- 2.2. Base material(s)/designation: . . . /
- 2.3. Composite/single (1) material, number of layers 1/:
- 2.4. Type of coating (1):
- 2.5. Maximum/minimum thickness mm
- 2.6. Type-approval number, if available:

1/ Delete where not applicable

Annex 3

(Maximum format: A4 (210 mm x 297 mm))

COMMUNICATION

issued by: Name of administration:
.....
.....
.....



concerning 2/: APPROVAL GRANTED
APPROVAL EXTENDED
APPROVAL REFUSED
APPROVAL WITHDRAWN
PRODUCTION DEFINITELY DISCONTINUED

of a vehicle type pursuant to Regulation No. XXXX

Approval No. Extension No.....

Reason for extension:

SECTION I

GENERAL

- 1.1. Make (trade name of manufacturer):
- 1.2. Type:
- 1.3. Means of identification of type, if marked on the vehicle/component/
separate technical unit 2/ b/:
- 1.3.1. Location of that marking:
- 1.4. Category of vehicle c/:
- 1.5. Name and address of manufacturer:
- 1.6. Location of the ECE approval mark:
- 1.7. Address(es) of assembly plant(s):

SECTION II

1. Additional information (where applicable)
2. Technical service responsible for carrying out the tests:
3. Date of test report:
4. Number of test report:
5. Remarks (if any):
6. Place:
7. Date:
8. Signature:
9. The index to the information package lodged with the approval authority, which may be obtained on request, is attached.

-
- 1/ Distinguishing number of the country which has granted/extended approval (see approval provisions in the Regulation)
- 2/ Strike out what does not apply (there are cases where nothing needs to be deleted, when more than one entry is applicable)
- b/ If the means of identification of type contains characters not relevant to describe the vehicle, component or separate technical unit types covered in this information document, such characters shall be represented in the documentation by the symbol A?@ (e.g. ABC??123??)
- c/ As defined in annex 7 to the Consolidated Resolution on the Construction of Vehicles (R.E.3) (document TRANS/WP.29/78/Rev.1/Amend.2, as amended).

Annex 4

(Maximum format: A4 (210 mm x 297 mm))

COMMUNICATION

issued by: Name of administration:
.....
.....
.....



concerning 2/: APPROVAL GRANTED
APPROVAL EXTENDED
APPROVAL REFUSED
APPROVAL WITHDRAWN
PRODUCTION DEFINITELY DISCONTINUED

of a component type pursuant to Regulation No. XXXX

Approval No. Extension No.

Reason for extension:

SECTION I

GENERAL

- 1.1. Make (trade name of manufacturer):
- 1.2. Type:
- 1.3. Means of identification of type, if marked on the device b/: ...
.....
- 1.3.1. Location of that marking:
- 1.4. Name and address of manufacturer:
- 1.5. Location of the ECE approval mark:
- 1.6. Address(es) of assembly plant(s):

SECTION II

- 1. Additional information (where applicable)
- 2. Technical service responsible for carrying out the tests:
.....
- 3. Date of test report:

4. Number of test report:
5. Remarks (if any):
6. Place:
7. Date:
8. Signature:
9. The index to the information package lodged with the approval authority, which may be obtained on request, is attached.

-
- 1/ Distinguishing number of the country which has granted/extended/refused/withdrawn approval (see approval provisions in the Regulation)
 - 2/ Strike out what does not apply (there are cases where nothing needs to be deleted, when more than one entry is applicable)
 - b/ If the means of identification of type contains characters not relevant to describe the vehicle, component or separate technical unit types covered in this information document, such characters shall be represented in the documentation by the symbol A?@ (e.g. ABC??123??)

Annex 5

ARRANGEMENTS OF APPROVAL MARKS

Example 1

(see Part I of this Regulation)

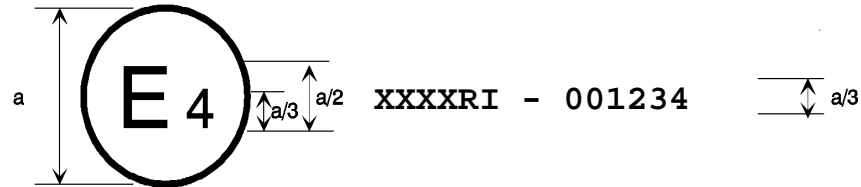

a = 8 mm min

The above approval mark affixed to a vehicle shows that the type concerned was approved in the Netherlands (E4) pursuant to Part I of Regulation No. XXXX under approval No. 001234. The first two digits (00) of the approval number indicate that the approval was granted in accordance with the requirements of Regulation No. XXXX in its original form.

Example 2

(see part II of this Regulation)

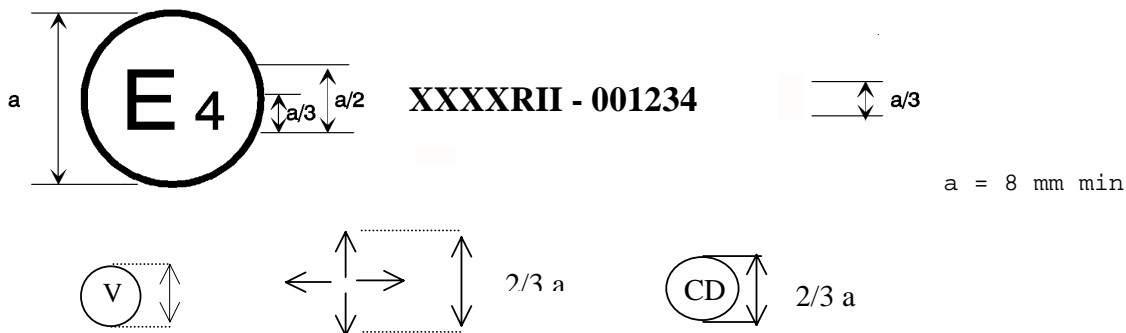

The above approval mark affixed to a component shows that the type concerned was approved in the Netherlands (E4) pursuant to Part II of Regulation No. XXXX under approval number 001234. The first two digits (00) of the approval number indicate that the approval was granted in accordance with the requirements of Regulation No. XXXX in its original form

The additional symbol $\left\langle \begin{array}{c} \uparrow \\ \downarrow \end{array} \right\rangle$ indicates that this type of component has been approved according to its horizontal and vertical burning rate.

The symbols \textcircled{V} and/or \textcircled{C} indicate an approval according to Annex 7 and/or an approval as a complete device such as seats, separation walls, etc.. The additional symbols are only used if applicable.

Annex 6

TEST TO DETERMINE THE HORIZONTAL BURNING RATE OF MATERIALS

1. Sampling and Principle
 - 1.1. Five samples shall undergo the test in the case of an isotropic material or ten samples in the case of a non-isotropic material (five for each direction).
 - 1.2. The samples shall be taken from the material under test. In materials having different burning rates in different material directions, each direction has to be tested. The samples are to be taken and placed in the test apparatus so that the highest burning rate will be measured. When the material is supplied in widths, a length of at least 500 mm shall be cut covering the entire width. From this the samples shall be taken so as to be at least 100 mm from the material edge and equidistant from each other. Samples shall be taken in the same way from finished products, when the shape of the product permits. When the thickness of the product is more than 13 mm, it shall be reduced to 13 mm by a mechanical process applied to the side which does not face the occupant compartment. If it is impossible, the test shall be carried out, in accordance with the Technical Service, on the initial width of the material which shall be mentioned in the test report.

Composite materials (see paragraph 6.1.6..) shall be tested as if they were of uniform construction. In the case of materials made of superimposed layers of different composition which are not composite materials, all the layers of material included within a depth of 13 mm from the surface facing towards the passenger compartment shall be tested individually.

- 1.3. A sample is held horizontally in a U-shaped holder and is exposed to the action of a defined low-energy flame for 15 seconds in a combustion chamber, the flame acting on the free end of the sample. The test determines if and when the flame extinguishes or the time in which the flame passes a measured distance.

2. Apparatus

- 2.1. Combustion chamber (figure 1), preferably of stainless steel and having the dimensions given in figure 2. The front of the chamber contains a flame-resistant observation window, which may cover the front and which can be constructed as an access panel.

The bottom of the chamber has vent holes, and the top has a vent slot all around. The combustion chamber is placed on four feet, 10 mm high.

The chamber may have a hole at one end for the introduction of the sample holder containing the sample; in the opposite end, a hole is provided for the gas line. Melted material is caught in a pan (see figure 3) which is placed on the bottom of the chamber between vent holes without covering any vent hole area.

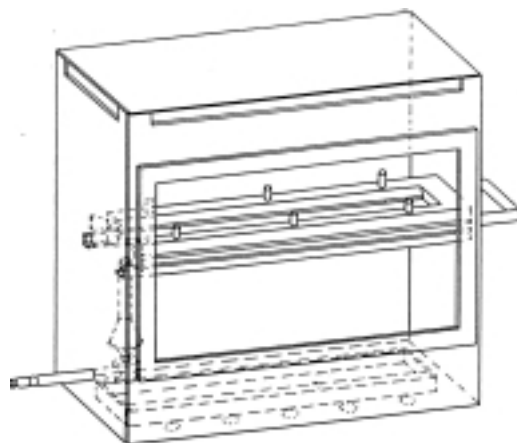

Figure 2
Example of combustion chamber with sample holder and drip tray

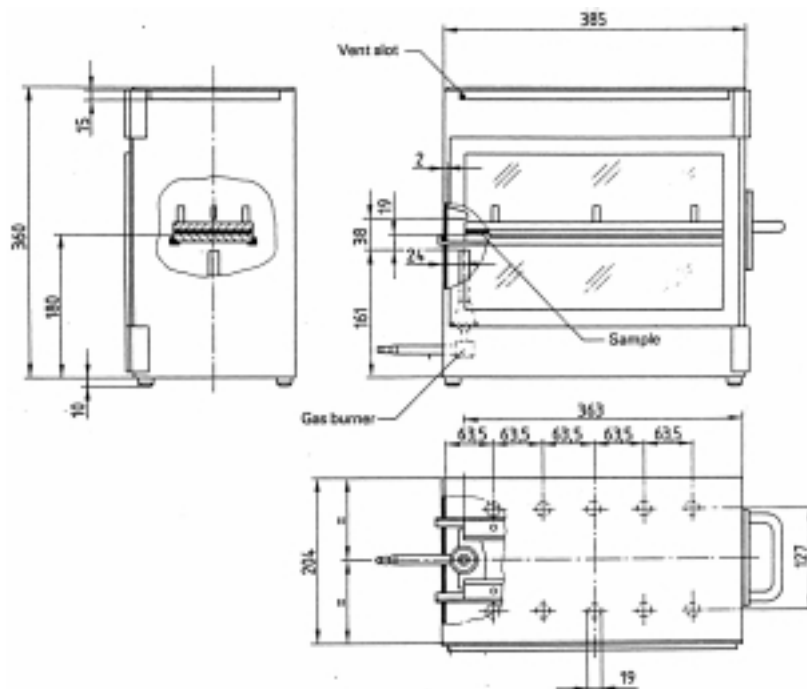

Figure 2
Example of combustion chamber
(Dimensions in millimetres)

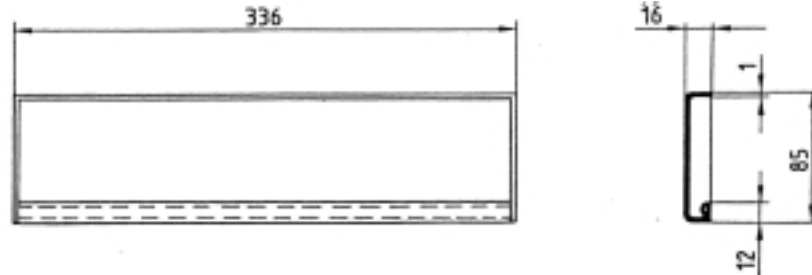

Figure 3
Typical drip pan
(Dimensions in millimetres)

2.2. Sample holder, consisting of two U-shaped metal plates or frames of corrosion-proof material. Dimensions are given in figure 4.

The lower plate is equipped with pins, the upper one with corresponding holes in order to ensure a consistent holding of the sample. The pins also serve as the measuring points at the beginning and end of the burning distance.

A support shall be provided in the form of 0.25 mm diameter heat resistant wires spanning the frame at 25 mm intervals over the bottom U-shaped frame (see figure 5).

The plane of the lower side of samples shall be 178 mm above the floor plate. The distance of the front edge of the sample holder from the end of the chamber shall be 22 mm; the distance of the longitudinal sides of the sample holder from the sides of the chamber shall be 50 mm (all inside dimensions). (See figures 1 and 2)

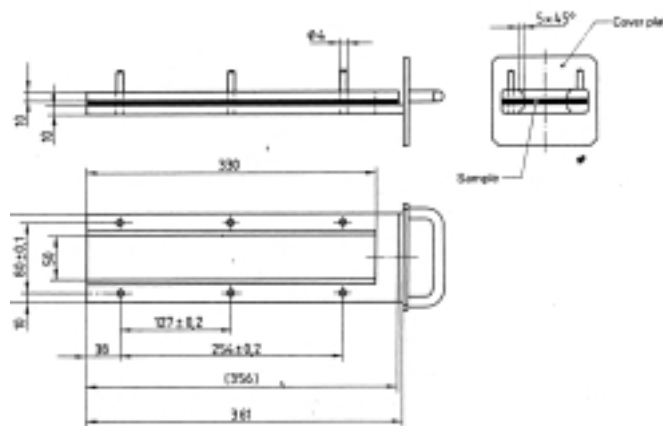

Figure 4
Example of sample holder
(Dimensions in millimeter)

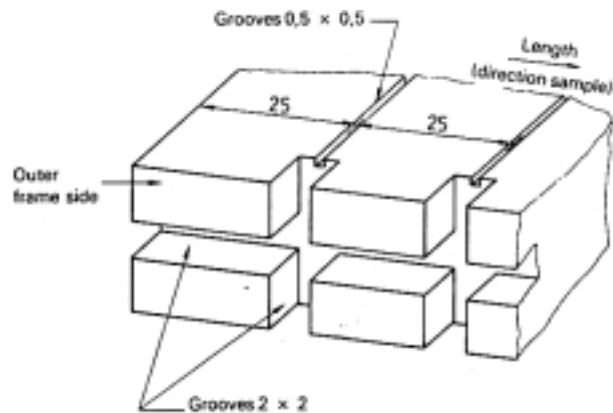

Figure 5

Example of section of lower U-frame design for wire support facility
(Dimensions in millimetres)

2.3. Gas burner

The small ignition source is provided by a Bunsen burner having an inside diameter of 9.5 ± 0.5 mm. It is located in the test cabinet so that the centre of its nozzle is 19 mm below the centre of the bottom edge of the open end of the sample (see figure 2).

2.4. Test gas

The gas supplied to the burner shall have a calorific value near 38 MJ/m^3 (for example natural gas).

2.5. Metal comb, at least 110 mm in length, with seven to eight smooth rounded teeth per 25 mm.

2.6. Stop-watch, accurate to 0.5 seconds.

2.7. Fume cupboard. The combustion chamber may be placed in a fume cupboard assembly provided that the internal volume is at least 20 times, but not more than 110 times, greater than the volume of the combustion chamber and provided that no single height, width, or length dimension of the fume cupboard is greater than 2.5 times either of the other two dimensions. Before the test, the vertical velocity of the air through the fume cupboard shall be measured 100 mm in front of and behind the final position where the combustion chamber will be located. It shall be between 0.10 and 0.30 m/s in order to avoid possible discomfort, by combustion products, to the operator. It is possible to use a fume cupboard with a natural ventilation and an appropriate air velocity.

3. Samples

3.1. Shape and dimensions

3.1.1. The shape and dimensions of samples are given in figure 6. The thickness of the sample corresponds to the thickness of the product to be tested. It shall not be more than 13 mm. When taking the

sample permits, the sample shall have a constant section over its entire length.

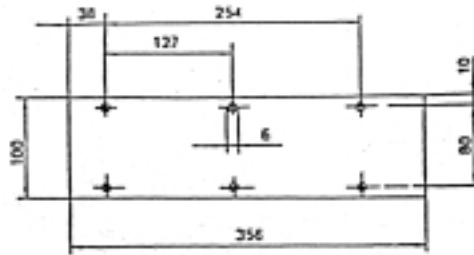

Figure 6
Sample
(Dimensions in millimetres)

3.1.2. If the shape and dimensions of a product do not permit taking a sample of the given size, the following minimum dimensions shall be maintained:

- (a) for samples having a width of 3 to 60 mm, the length shall be 356 mm. In this case the material is tested in the product's width;
- (b) for samples having a width of 60 to 100 mm, the length shall be at least 138 mm. In this case the potential burning distance corresponds to the length of the sample, the measurement starting at the first measuring point.

3.2. Conditioning

The samples shall be conditioned for at least 24 hours but not more than 7 days at a temperature of $23^{\circ}\text{C} \pm 2^{\circ}\text{C}$ and a relative humidity of 50 ± 5 per cent and shall be maintained under these conditions until immediately prior to testing.

4. Procedure

- 4.1. Place samples with napped or tufted surfaces on a flat surface and comb twice against the nap using the comb (paragraph 2.5.).
- 4.2. Place the sample in the sample holder (paragraph 2.2.) so that the exposed side will be downwards to the flame.
- 4.3. Adjust the gas flame to a height of 38 mm using the mark in the chamber, the air intake of the burner being closed. Before starting the first test, the flame shall burn at least for 1 min for stabilization
- 4.4. Push the sample-holder into the combustion chamber so that the end of the sample is exposed to the flame, and after 15 seconds cut off the gas flow.
- 4.5. The measurement of the burning time starts at the moment when the foot of the flame passes the first measuring point. Observe the flame propagation on the side burning faster than the other (upper or lower side).

- 4.6. Measurement of burning time is completed when the flame has come to the last measuring point or when the flame extinguishes before coming to the last measuring point. If the flame does not reach the last measuring point, measure the burnt distance up to the point where the flame extinguished. Burnt distance is the decomposed part of the sample, which is destroyed on its surface or in the interior by burning.
- 4.7. In so far as the sample does not ignite or does not continue burning after the burner has been extinguished, or when the flame extinguishes before reaching the first measuring point, so that no burning time is measured note in the test report that the burning rate is 0 mm/min.
- 4.8. When running a series of tests or repeat tests, ensure that the combustion chamber and sample holder have a maximum temperature of 30°C before starting the next test.

5. Calculation

The burning rate, B ¹/₁, in millimetres per minute, is given by the formula:

$$B = 60 s/t$$

where:

s = the burnt distance, in millimetres;

t = the time, in seconds, to burn distance s

¹/ The burning rate (B) for each sample is only calculated in the case where the flame reaches the last measuring point or the end of the sample.

Annex 7

TEST TO DETERMINE THE MELTING BEHAVIOUR OF MATERIALS

1. Sampling and principle

1.1. Four samples, for both faces (if they are not identical) shall undergo the test.

1.2. A sample is placed in a horizontal position and is exposed to an electric radiator. A receptacle is positioned under the specimen to collect the resultant drops. Some cotton wool is put in this receptacle in order to verify if any drop is flaming.

2. Apparatus

The apparatus shall consist of (figure 1):

- (a) an electric radiator;
- (b) a support for the sample with grill;
- (c) a receptacle (for resultant drops);
- (d) a support (for the apparatus)

2.1. The source of heat is an electric radiator with a useful output of 500 W. The radiating surface must be made of a transparent quartz plate with a diameter of 100 ± 5 mm.

The radiated heat from the apparatus, measured on a surface which is situated parallel to the surface of the radiator at a distance of 30 mm, shall be 3 W/cm^2 .

2.2. Calibration

For calibration of the radiator, a heat flux meter (radiometer) of the Gardon (foil) type with a design range not exceeding 10 W/cm^2 shall be used. The target receiving radiation, and possibly to a small extent convection, shall be flat, circular, not more than 10 mm in diameter and coated with a durable matt black finish.

The target shall be contained within a water cooled body the front face of which shall be of highly polished metal, flat, coinciding with the plane of the target and circular, with a diameter of about 25 mm.

Radiation shall not pass through any window before reaching the target.

The instrument shall be robust, simple to set up and use, insensitive to draughts, and stable in calibration. The instrument shall have an accuracy of within ± 3 per cent and a repeatability within 0.5 per cent.

The calibration of the heat flux meter shall be checked whenever a recalibration of the radiator is carried out, by comparison with an instrument held as a reference standard and not used for any other purpose.

The reference standard instrument shall be fully calibrated at yearly intervals in accordance with a national standard.

2.2.1. Calibration check

The irradiance produced by the power input which the initial calibration has shown to correspond to an irradiance of 3 W/cm² shall be frequently checked (at least once every 50 operating hours) and the apparatus shall be recalibrated if such a check reveals a deviation greater than 0.06 W/cm².

2.2.2. Calibration procedure

The apparatus shall be placed in an environment essentially free of air currents (not more than 0.2 m/s).

Place the heat flux meter in the apparatus in the specimen position so that the target of the heat flux meter is located centrally within the radiator surface.

Switch on the electricity supply and establish the power input of the controller required to produce irradiance at the centre of the radiator surface of 3 W/cm². Adjustment to the power unit to record 3 W/cm² should be followed by a five minute period without further adjustment to ensure equilibrium.

2.3. The support for the samples shall be a metallic ring (figure 1). On top of this support a grill, made of stainless steel-wire, is placed with the following dimensions:

- (a) interior diameter: 118 mm,
- (b) dimension of the holes: 2.10 mm square,
- (c) diameter of the steel-wire: 0.70 mm.

2.4. The receptacle shall consist of a cylindrical tube with an interior diameter of 118 mm and a depth of 12 mm. The receptacle shall be filled with cotton wool.

2.5. A vertical column shall support the items specified in paragraphs 2.1., 2.3. and 2.4.

The radiator is placed on top of the support in a manner such that the radiating surface is horizontal and the radiation is downwards.

A lever/pedal shall be provided in the column to lift the support of the radiator slowly. It shall also be provided with a catch in order to ensure that the radiator can be brought back in its normal position.

In their normal position, the axes of the radiator, the support for the sample and the receptacle must coincide

3. Samples

The test samples shall measure: 70 mm x 70 mm. Samples shall be taken in the same way from finished products, when the shape of the product permits. When the thickness of the product is more than 13 mm, it shall be reduced to 13 mm by a mechanical process applied to the side which does not face the occupant compartment. If it is impossible, the test shall be

carried out, in accordance with the Technical Service, on the initial width of the material which shall be mentioned in the test report.

Composite materials (see paragraph 6.1.3. of the Regulation) shall be tested as if they were of uniform construction.

In the case of materials made of superimposed layers of different composition which are not composite materials, all the layers of material included within a depth of 13 mm from the surface facing towards the passenger compartment shall be tested individually.

The total mass of the sample to be tested shall be at least 2 g. If the mass of one sample is less, a sufficient number of samples shall be added.

If the two faces of the material differ, both faces must be tested, which means that eight samples are to be tested. The samples and the cotton wool shall be conditioned for at least 24 hours at a temperature $23^{\circ}\text{C} \pm 2^{\circ}\text{C}$ and a relative humidity of 50 ± 5 per cent and shall be maintained under these conditions until immediately prior to testing

4. Procedure

The sample is placed on the support and the latter is so positioned that the distance between the surface of the radiator and the upper side of the sample is 30 mm.

The receptacle, including the cotton wool, is placed beneath the grill of the support at a distance of 300 mm.

The radiator is put aside, so that it cannot radiate on the sample, and switched on. When it is on full capacity it is positioned above the sample and timing is started.

If the material melts or deforms, the height of the radiator is modified to maintain the distance of 30 mm.

If the material ignites, the radiator is put aside three seconds afterwards. It is brought back in position when the flame has extinguished and the same procedure is repeated as frequently as necessary during the first five minutes of the test.

After the fifth minute of the test:

- (i) If the sample has extinguished (whether or not it has ignited during the first five minutes of the test) leave the radiator in position even if the sample reignites,
- (ii) If the material is flaming, await extinction before bringing the radiator into position again.

In either case, the test must be continued for an additional five minutes.

5. Results

Observed phenomena shall be noted in the test-report, such as:

- (i) the fall of drops, if any, whether flaming or not,
- (ii) if ignition of the cotton wool has taken place

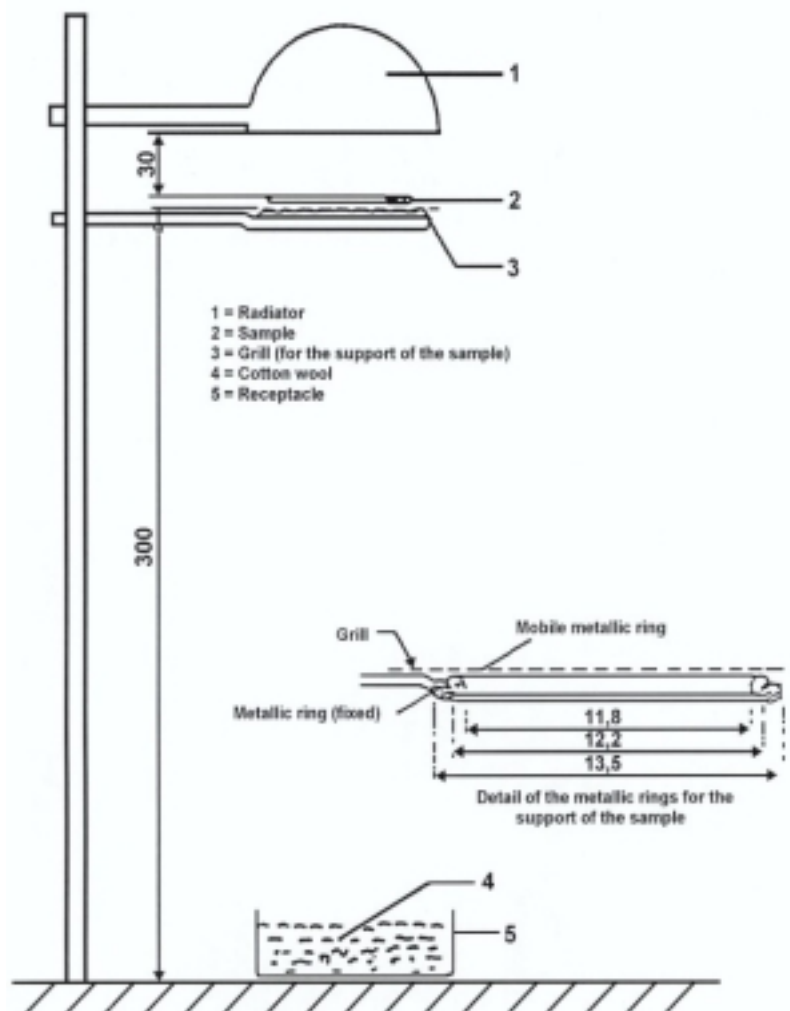

Figure 1
(Dimensions in millimeters)

Annex 8

TEST TO DETERMINE THE VERTICAL BURNING RATE OF MATERIALS

1. Sampling and Principle
 - 1.1. Three samples shall undergo the test in the case of an isotropic material, or six samples in the case of a non-isotropic material.
 - 1.2. This test consists of exposing samples, held in a vertical position, to a flame and determining the speed of propagation of the flame over the material to be tested.
2. Apparatus

The apparatus shall consist of:

 - (a) a specimen holder;
 - (b) a burner;
 - (c) a ventilation system to extract gas and combustion products;
 - (d) a template;
 - (e) marker threads of white mercerized cotton threads having a maximum linear density of 50 tex.
- 2.1. The specimen holder shall consist of a rectangular frame of 560 mm high and shall have two rigidly connected parallel rods spaced 150 mm apart on which pins shall be fitted for mounting the test specimen which is located in a plane at least 20 mm from the frame. The mounting pins shall be not greater than 2 mm in diameter and at least 27 mm long. The pins shall be located on the parallel rods at locations shown in figure 1. The frame shall be fitted onto a suitable support to maintain the rods in a vertical orientation during testing (for the purpose of locating the specimen on the pins in a plane away from the frame, spacer stubs 2 mm in diameter may be provided adjacent to the pins).
- 2.2. The burner is described in figure 3.

The gas supplied to the burner can be either commercial propane gas or commercial butane gas.

The burner shall be positioned in front of, but below, the specimen such that it lies in a plane passing through the vertical centerline of the specimen and perpendicular to its face (see figure 2), such that the longitudinal axis is inclined upwards at 30° to the vertical towards the lower edge of the specimen. The distance between the tip of the burner and the lower edge of the specimen shall be 20 mm.
- 2.3. The test apparatus may be placed in a fume cupboard assembly provided that the internal volume is at least 20 times, but not more than 110 times, greater than the volume of the test apparatus and provided that: no single height, width, or length dimension of the fume cupboard is greater than 2.5 times either of the other two

dimensions. Before the test, the vertical velocity of the air through the fume cupboard shall be measured 100 mm in front of and behind the final position where the test apparatus will be located. It shall be between 0.10 and 0.30 m/s in order to avoid possible discomfort, by combustion products, to the operator. It is possible to use a fume cupboard with a natural ventilation and an appropriate air velocity.

2.4. A flat rigid template made of suitable material and of a size corresponding to the size of the specimen shall be used. Holes approximately 2 mm in diameter shall be drilled in the template and positioned so that the distances between the centres of the holes correspond to the distances between the pins on the frames (see figure 1). The holes shall be located equidistant about the vertical centrelines of the template.

3. Samples

3.1. The samples dimensions are: 560 x 170 mm

3.2. The samples shall be conditioned for at least 24 hours at a temperature of $23^{\circ}\text{C} \pm 2^{\circ}\text{C}$ and a relative humidity of 50 ± 5 per cent and shall be maintained under these conditions until immediately prior to testing.

4. Procedure

4.1. The test shall be carried out in an atmosphere having a temperature between 10°C and 30°C and a relative humidity between 15 per cent and 80 per cent.

4.2. The burner shall be preheated for 2 minutes. The flame height shall be adjusted to 40 ± 2 mm measured as the distance between the top of the burner tube and the tip of the yellow part of the flame when the burner is vertically oriented and the flame is viewed in dim light.

4.3. The specimen shall be placed on the pins of the test frame, making certain that the pins pass through the points marked off from the template and that the specimen is at least 20 mm removed from the frame. The frame shall be fitted on the support so that the specimen is vertical.

4.4. The marker threads shall be attached horizontally in front of the specimen at the locations shown in figure 1. At each location, a loop of thread shall be mounted so that the two segments are spaced 1 mm and 5 mm from the plane of the front of the specimen.

Each loop shall be attached to a suitable timing device. Sufficient tension shall be imposed to the thread to maintain its position relative to the specimen.

4.5. The flame shall be applied to the specimen for 5 seconds. Ignition shall be deemed to have occurred if flaming of the specimen continues for 5 seconds after removal of the igniting flame. If ignition does not occur, the flame shall be applied for 15 seconds to another conditioned specimen.

4.6. If any result in any set of three specimens exceeds the minimum result by 50 per cent, another set of three specimens shall be tested for that direction or face. If one or two specimens in any set of three specimens fail to burn to the top marker thread, another set of three specimens shall be tested for that direction or face.

4.7. The following times, in seconds, shall be measured:

- (a) from the start of the application of the igniting flame to the severance of the first marker thread (t_1);
- (b) from the start of the application of the igniting flame to the severance of the second marker thread (t_2);
- (c) from the start of the application of the igniting flame to the severance of the third marker thread (t_3).

5. Results

The observed phenomena shall be written down in the test-report, to include:

- (i) the durations of combustion: t_1 , t_2 and t_3 in seconds, and
- (ii) the corresponding burnt distances: d_1 , d_2 and d_3 in mm.

The burning rate V_1 and the rates V_2 and V_3 , if applicable, shall be calculated (for each sample if the flame reaches at least the first marker thread) as follows:

$$V_i = 60 d_i/t_i \text{ (mm/min)}$$

The highest burning rate of V_1 , V_2 and V_3 shall be taken into account.

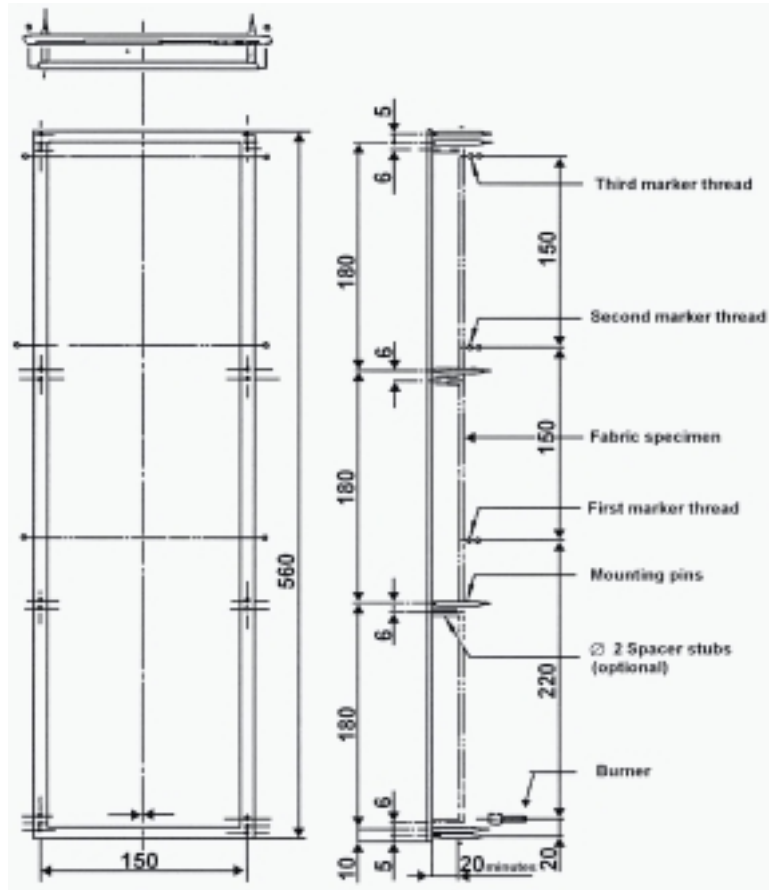

Figure 1
Specimen holder
(Dimensions in millimetres)

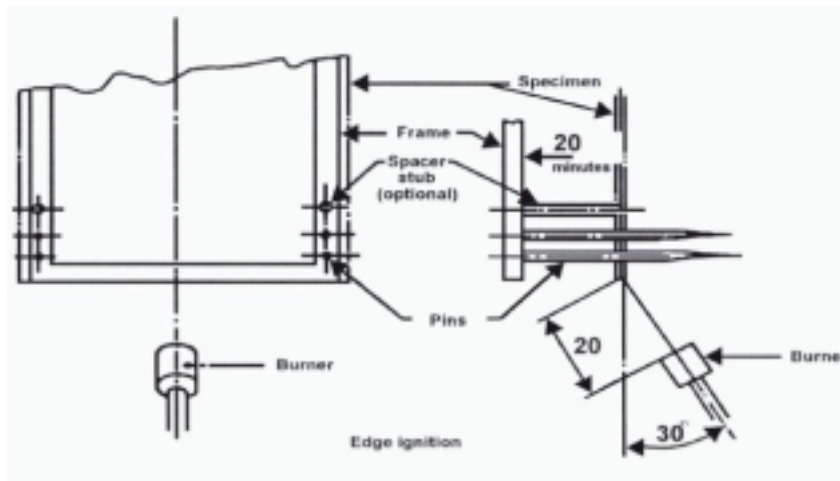

Figure 2
Burner ignition location

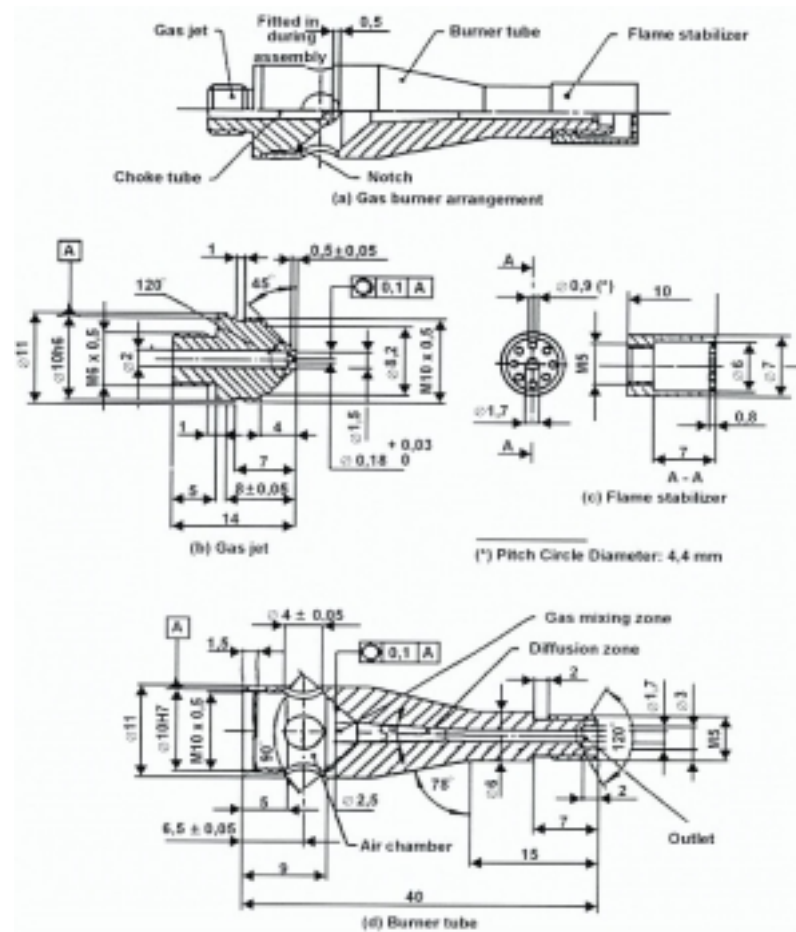

Figure 3
Gas burner
(Dimensions in millimetres)