

Distr.
GENERAL

TRANS/WP.29/GRSP/2001/1
8 February 2001

ENGLISH ONLY

ECONOMIC COMMISSION FOR EUROPE

INLAND TRANSPORT COMMITTEE

World Forum for Harmonization of Vehicle Regulations (WP.29)

Working Party on Passive Safety (GRSP)
(Twenty-ninth session, 7-11 May 2001,
agenda item 2.1.)

PROPOSAL FOR DRAFT CANDIDATE GLOBAL TECHNICAL REGULATION
ON DOOR LATCHES AND DOOR RETENTION COMPONENTS

Transmitted by the Expert from the International Organization of
Motor Vehicle Manufacturers (OICA)

Note: The text reproduced below was prepared by the expert from OICA as a
basis for consideration of a new global technical regulation.

Note: This document is distributed to the Experts on Passive Safety only.

GE.01-

DOOR LOCKS AND RETENTION COMPONENTS FMVSS 206 AND ECE R.11.02

		<i>FMVSS 206</i>	<i>ECE R11.02</i>	<i>TECHNICAL DIFFERENCES IN REGULATIONS</i>	<i>DRAFT GLOBAL REGULATION</i>
1. SCOPE		<p>Door locks, latches, hinges for passenger cars, MPVs and trucks:</p> <ul style="list-style-type: none"> - side door leading directly into a compartment containing seating position(s) - back door of passenger cars or MPV manufactured as of Sept. 1, 1997 and with a GVWR \leq 4,536 kg (10,000 lb). 	<p>Side doors (latches, hinges) used for entry/exit of occupants: of M1 (passenger cars \leq 9 seats) and N1 vehicles (light commercial vehicles \leq 3500 kg) .</p>	<p>FMVSS applies to more types of vehicles than EU/ECE.</p> <p>FMVSS applies to any door (i.e. side and back) and EU/ECE excludes back doors.</p> <p>EU only applies to passenger cars, while ECE also covers light commercials</p>	<p>Door locks, latches, hinges for M1 passenger cars :</p> <ul style="list-style-type: none"> - side door leading directly into compartment containing seating positions - back doors, excluding <ul style="list-style-type: none"> . trunk lids . locks, hatches, hinges of doors or windows entirely composed of glazing material, which are attached directly to the glazing material
2. LATCHES					
2.1	HINGED SIDE DOORS				
2.1.1		<p>Hinged doors must have:</p> <ul style="list-style-type: none"> - a fully latched position; and - a secondary latched position. 	<p>Hinged doors must have:</p> <ul style="list-style-type: none"> - a fully latched position; and - an intermediate latched position 	None	<p><i>Take US :</i></p> <p>Hinged doors must have:</p> <ul style="list-style-type: none"> - a fully latched position; and - a secondary latched position.
2.1.2		<p>Longitudinal loads:</p> <p>Latch / striker assembly must withstand a longitudinal load of</p> <ul style="list-style-type: none"> - 4,450 N in secondary latched position - 11,000 N in fully latched position 	<p>Longitudinal loads:</p> <p>Latch / striker assembly must withstand a longitudinal load of</p> <ul style="list-style-type: none"> - 4,440 N in intermediate latched position - 11,110 N in fully latched position. 	None, except for rounding-off of the figures	<p><i>Take US :</i></p> <p>Longitudinal loads:</p> <p>Latch / striker assembly must withstand a longitudinal load of</p> <ul style="list-style-type: none"> - 4,450 N in secondary latched position - 11,000 N in fully latched position
2.1.3		<p>Transverse loads:</p> <p>Latch / striker assembly must withstand a transversal load of:</p> <ul style="list-style-type: none"> - 4450 N in secondary latched position - 8900 N in fully latched position 	<p>Transverse loads:</p> <p>Latch / striker assembly must withstand a transversal load of:</p> <ul style="list-style-type: none"> - 4440 N in intermediate latched position - 8890 N in fully latched position. 	None, except for rounding-off of the figures	<p><i>Take US :</i></p> <p>Transverse loads:</p> <p>Latch / striker assembly must withstand a transversal load of:</p> <ul style="list-style-type: none"> - 4450 N in secondary latched position - 8900 N in fully latched position
2.1.4		<p>Inertia loads:</p> <p>The door latch assembly shall not disengage from the fully latched position when a longitudinal or transverse load of 30g is applied to the door latch system (including the latch and its actuating mechanism with the locking mechanism disengaged).</p>	<p>Inertia loads:</p> <p>The door latch shall not move from the fully latched position when an acceleration of 30g is applied in both directions longitudinally and transversally to the latch, including its actuating mechanism, with the locking mechanism disengaged.</p>	Not significant : only editorial differences	<p><i>Take US :</i></p> <p>Inertia loads:</p> <p>The door latch assembly shall not disengage from the fully latched position when a longitudinal or transverse load of 30g is applied to the door latch system (including the latch and its actuating mechanism with the locking mechanism disengaged).</p>

DOOR LOCKS AND RETENTION COMPONENTS FMVSS 206 AND ECE R.11.02

		<i>FMVSS 206</i>	<i>ECE R11.02</i>	<i>TECHNICAL DIFFERENCES IN REGULATIONS</i>	<i>DRAFT GLOBAL REGULATION</i>
2. LATCHES (cont'd)					
2.2	HINGED SIDE DOORS, CARGO TYPE				Cargo-type doors are defined as double doors ; while such double doors are possible in theory on the sides of passenger cars, it is considered that such side doors should meet the same requirements as classical side doors (see section 2.1). Therefore, this whole section could be deleted.
	2.2.1	No particular requirement	Hinged doors must have: - a fully latched position; and - an intermediate latched position	FMVSS does not require intermediate latched position on cargo type side doors	Delete
	2.2.2	Longitudinal loads: Latch / striker assembly must withstand a longitudinal load of - 11,000 N in fully latched position	Longitudinal loads: Latch / striker assembly must withstand a longitudinal load of - 4,440 N in intermediate latched position - 11,110 N in fully latched position.	FMVSS does not require intermediate latched position on cargo type side doors	Delete
	2.2.3	Transverse loads: Latch / striker assembly must withstand a transversal load of: - 8900 N in fully latched position	Transverse loads: Latch / striker assembly must withstand a transversal load of: - 4440 N in intermediate latched position - 8890 N in fully latched position.	FMVSS does not require intermediate latched position on cargo type side doors	Delete
	2.2.4	No requirement	Inertia loads: The door latch shall not move from the fully latched position when an acceleration of 30g is applied in both directions longitudinally and transversally to the latch, including its actuating mechanism, with the locking mechanism disengaged.	Inertia load test is not required in FMVSS	Delete

DOOR LOCKS AND RETENTION COMPONENTS FMVSS 206 AND ECE R.11.02

		<i>FMVSS 206</i>	<i>ECE R11.02</i>	<i>TECHNICAL DIFFERENCES IN REGULATIONS</i>	<i>DRAFT GLOBAL REGULATION</i>
2. LATCHES (cont'd)					
2.3	HINGED BACK DOORS				
	2.3.1	Each back door must have at least one primary latch and striker assembly with: - a fully latched position; and - a secondary latched position	No requirement	EU/ECE do not apply to back doors.	<i>Take US :</i> Each back door must have at least one primary latch and striker assembly with: - a fully latched position; and - a secondary latched position
	2.3.2	<u>Load test one:</u> - fully latched: 11,000 N - secondary latch: 4,450 N Application of load: perpendicular to the face of the latch such that the latch and striker anchorage are not compressed against each other	No requirement	EU/ECE do not apply to back doors.	<i>Take US :</i> <u>Load test one:</u> - fully latched: 11000 N - secondary latch: 4450 N Application of load: perpendicular to the face of the latch such that the latch and striker anchorage are not compressed against each other
	2.3.3	<u>Load test two:</u> - fully latched: 8,900 N - secondary latch: 4,450 N Application of load: in the direction of the fork-bolt opening and parallel to the face of the latch	No requirement	EU/ECE do not apply to back doors.	<i>Take US :</i> <u>Load test two:</u> - fully latched: 8900 N - secondary latch: 4,450 N Application of load: in the direction of the fork-bolt opening and parallel to the face of the latch
	2.3.4	<u>Load test three:</u> Back door, opening upwards: Fully latched position shall not disengage under load of 8,900 N Application of load: orthogonal to directions of load tests one and two	No requirement	EU/ECE do not apply to back doors.	<i>Take US :</i> <u>Load test three:</u> Back door, opening upwards: Fully latched position shall not disengage under load of 8,900 N Application of load: orthogonal to directions of load tests one and two
	2.3.5	<u>Inertia load:</u> Fully latched position shall not disengage under inertia load of 30 g. Application of inertia load: in the directions of load tests one, two and three	No requirement	EU/ECE do not apply to back doors.	<i>Take US :</i> <u>Inertia load:</u> Fully latched position shall not disengage under inertia load of 30 g. Application of inertia load: in the directions of load tests one, two and three
	2.3.6	Auxiliary back door latches if present, must comply with load tests one and two and inertia load described above.	No requirement	EU/ECE do not apply to back doors.	<i>Take US :</i> Auxiliary back door latches if present, must comply with load tests one and two and inertia load described above.

DOOR LOCKS AND RETENTION COMPONENTS FMVSS 206 AND ECE R.11.02

		<i>FMVSS 206</i>	<i>ECE R11.02</i>	<i>TECHNICAL DIFFERENCES IN REGULATIONS</i>	<i>DRAFT GLOBAL REGULATION</i>
3. HINGES					
3.1	SIDE DOOR				
	3.1.1	No requirement	The retention components of hinged mounted side doors, other than folding doors, shall be mounted at the forward edge in the direction of travel. In the case of double doors, this requirement shall apply to the door wing which opens first, the other wing shall be capable of being bolted	Rear hinging of side doors prohibited in ECE, except for double doors.	Hinged side doors shall not have their hinges mounted on the rear of the door. In the case of double doors this prohibition shall only apply to the door wing which opens first ; the other wing shall be capable of being bolted.
	3.1.2	Longitudinal and transverse loads: Each side door hinge system must: - support the door - withstand a longitudinal load of 11,000 N - withstand a transverse load of 8,900 N.	Longitudinal and transverse loads: The retention components must: - support the door - withstand a longitudinal load of 11,110 N - withstand a transverse load of 8,890 N.	None, except for rounding of figures	<i>Take US :</i> Longitudinal and transverse loads: Each side door hinge system must: - support the door - withstand a longitudinal load of 11,000 N - withstand a transverse load of 8,900 N.
3.2	BACK DOORS				
	3.2.1	Load test one: each back door hinge system shall - support the door - shall not separate under load of 11,000 N Application of load: perpendicular to the hinge face plate such that the hinge plates are not compressed against each other	No requirement	ECE does not apply to back doors	<i>Take US :</i> Load test one: each back door hinge system shall - support the door - shall not separate under load of 11,000 N Application of load: perpendicular to the hinge face plate such that the hinge plates are not compressed against each other
	3.2.2	Load test two: No separation under load of 8,900N Application of load: perpendicular to the axis of the hinge pin and parallel to the hinge face plate such that the hinge plates are not compressed against each other	No requirement	ECE does not apply to back doors	<i>Take US :</i> Load test two: No separation under load of 8,900N Application of load: perpendicular to the axis of the hinge pin and parallel to the hinge face plate such that the hinge plates are not compressed against each other
	3.2.3	Load test three: Back doors opening upward: no separation under load of 8,900N Application of load: in the direction of the axis of the hinge pin	No requirement	ECE does not apply to back doors	<i>Take US :</i> Load test three: Back doors opening upward: no separation under load of 8,900N Application of load: in the direction of the axis of the hinge pin

DOOR LOCKS AND RETENTION COMPONENTS FMVSS 206 AND ECE R.11.02

		<i>FMVSS 206</i>	<i>ECE R11.02</i>	<i>TECHNICAL DIFFERENCES IN REGULATIONS</i>	<i>DRAFT GLOBAL REGULATION</i>
4. DOOR LOCKS					
4.1	HINGED SIDE DOORS				
	4.1.1	Each door shall be equipped with a locking mechanism with an operating means in the interior of the vehicle	No requirement	No official requirement in EU/ECE	<i>Take US :</i> Each door shall be equipped with a locking mechanism with an operating means in the interior of the vehicle
	4.1.2	Side front door locks: when the locking mechanism is engaged, the outside door handle or other outside latch release control shall be inoperative	No requirement	No official requirement in EU/ECE	<i>Take US :</i> Side front door locks: when the locking mechanism is engaged, the outside door handle or other outside latch release control shall be inoperative
	4.1.3	Side rear door locks: in passenger cars and MPVs when the locking mechanism is engaged, both the outside and inside handles or other latch release controls shall be inoperative	No requirement	No official requirement in EU/ECE	<i>Take US :</i> Side rear door locks: when the locking mechanism is engaged, both the outside and inside handles or other latch release controls shall be inoperative. <i>Add :</i> This requirement shall not apply to door lock mechanism fitted with a child lock. Child lock means a device which, when engaged, prevents opening of the respective side rear door(s), from the rear seat(s), by the interior opening mechanism(s) (definition to be added in future section "definitions").
4.2	HINGED BACK DOORS				
	4.2.1	Each back door system equipped with interior door handles or that leads directly into a compartment that contains one or more seating accommodations shall be equipped with a locking mechanism with operating means in both the interior and exterior of the vehicle. When the locking mechanism is engaged, both inside and outside door handles or other latch release controls shall be inoperative.	No requirement	No official requirement in EU/ECE	<i>Take US :</i> Each back door system equipped with interior door handles or that leads directly into a compartment that contains one or more seating accommodations shall be equipped with a locking mechanism with operating means in both the interior and exterior of the vehicle. When the locking mechanism is engaged, both inside and outside door handles or other latch release controls shall be inoperative. <i>Add :</i> If back door is equipped with child lock, latter requirement on inside door handle does not apply.

DOOR LOCKS AND RETENTION COMPONENTS FMVSS 206 AND ECE R.11.02

		<i>FMVSS 206</i>	<i>ECE R11.02</i>	<i>TECHNICAL DIFFERENCES IN REGULATIONS</i>	<i>DRAFT GLOBAL REGULATION</i>
5. SLIDING DOORS					
5.1		No requirement	Sliding doors without intermediate latched position: if the door is not fully latched, it must automatically move away to a partially open position; readily apparent to the vehicle occupants	Unique ECE requirement for sliding doors without intermediate latch position to automatically move away from latch if the door does not reach the fully latched position.	<i>Take ECE :</i> Sliding doors without secondary latched position : if the door is not fully latched, it must automatically move away to a partially open position; readily apparent to the vehicle occupants
5.2		Track and slide combination or other supporting means of side and back sliding doors shall not separate under total transverse (longitudinal for back door) load of 17,800 N	Track and slide combination or other supporting means of side sliding doors shall not separate under outward transverse load of 17,800 N (8,890 N to each load bearing member at opposite edges of door).	ECE does not apply to sliding back doors The ECE Regulation also seems to apply the load at a rate ≤ 5 mm/min, which seems to be an error	<i>Take ECE, but include back door + slight clarifications :</i> For sliding doors, the components used to attach the door to the vehicle structure shall not separate when an outward transverse (longitudinal for rear door) load of 17,8 kN shared between all points of attachment between the door and the structure with the door in the closed, fully latched, position. The test may be performed either on the vehicle or with the door retention components in a bench test fixture.
5.3		No requirement	Longitudinal loads: Latch / striker assembly must withstand a longitudinal load of - 4,440 N in intermediate latched position - 11,110 N in fully latched position.	FMVSS excludes side sliding door latches from having to comply with these requirements.	<i>Take ECE (slight amendment) :</i> Longitudinal loads: Latch / striker assembly must withstand a longitudinal load of - 4,450 N in secondary latched position - 11,000 N in fully latched position.
5.4		No requirement	Transverse loads: Latch / striker assembly must withstand a transversal load of: - 4440 N in intermediate latched position - 8890 N in fully latched position.	FMVSS excludes side sliding door latches from having to comply with these requirements.	<i>Take ECE (slight amendment) :</i> Transverse loads: Latch / striker assembly must withstand a transversal load of: - 4450 N in secondary latched position - 8900 N in fully latched position
5.5		No requirement	Inertia loads: Door latch shall not move from fully latched position when acceleration of 30g is applied longitudinally and transversally to the latch, including its actuating mechanism, with the locking mechanism disengaged.	FMVSS excludes side sliding door latches from having to comply with these requirements.	<i>Take ECE :</i> Inertia loads: Door latch shall not move from fully latched position when acceleration of 30g is applied longitudinally and transversally to the latch, including its actuating mechanism, with the locking mechanism disengaged.

DOOR LOCKS AND RETENTION COMPONENTS FMVSS 206 AND ECE R.11.02

		<i>FMVSS 206</i>	<i>ECE R11.02</i>	<i>TECHNICAL DIFFERENCES IN REGULATIONS</i>	<i>DRAFT GLOBAL REGULATION</i>
6. TEST PROCEDURES					
6.1	SIDE DOOR LATCHES				
	6.1.1	Longitudinal load (SAE J839b): - Attach latch and striker to test fixture. - Locate weights to apply 890 N tending to separate latch and striker in direction of door opening. - Apply test load perpendicular to latch face at a rate ≤ 5 mm/min.	Longitudinal loads: - Attach latch and striker to test fixture. - Locate weights to apply 890 N tending to separate latch and striker in direction of door opening. - Apply test load perpendicular to latch face at a rate ≤ 5 mm/min.	None - see figure	Longitudinal loads: - Attach latch and striker to test fixture. - Locate weights to apply 890 N tending to separate latch and striker in direction of door opening. - Apply test load perpendicular to latch face at a rate ≤ 5 mm/min.
	6.1.2	Transverse load (SAE J839b): - Attach latch and striker to test fixture - Apply load in line with the contacting surfaces of latch and striker, in door opening direction at a rate ≤ 5 mm/min.	Transverse load: - Attach latch and striker to test fixture - Apply load in line with contacting surfaces of latch and striker, horizontal and transverse to vehicle in door opening direction at rate ≤ 5 mm/min.	None - see figure	Transverse load (SAE J839b): - Attach latch and striker to test fixture - Apply load in line with the contacting surfaces of latch and striker, in door opening direction at a rate ≤ 5 mm/min.
	6.1.3	Inertia load (SAE J839b): calculation of complete door latch system (i.e. door latch, striker, outside and inside handle, key cylinder and any connecting mechanisms) in the fully latched position, showing that the system will remain in the fully latched position when subjected to an inertia load of 30g in any direction	Inertia load: either dynamic test or analytical calculation. Dynamic test: -vehicle itself or simulated structure secured to a chassis with door lock system fully latched - acceleration of 30 to 36 g applied to the chassis for at least 30 msec in forward direction parallel to vehicle longitudinal axis as well as in direction of the door opening, perpendicular to above described first direction - when equipped with lock device ensure that it does not come into action during the tests. Analytical means: calculation (same as SAE J839b)	Not significant	Inertia load: either dynamic test or analytical calculation. Dynamic test: -vehicle itself or simulated structure secured to a chassis with door lock system fully latched - acceleration of 30 to 36 g applied to the chassis for at least 30 msec in forward direction parallel to vehicle longitudinal axis as well as in direction of the door opening, perpendicular to above described first direction - when equipped with lock device ensure that it does not come into action during the tests.
6.2	BACK DOOR LATCHES				
	6.2.1	- Load test one, two and three: same as for side door latches, longitudinal load, except that the test load must be applied in the directions specified in load tests one, two and three - Inertia loads: same as for side door latches			- Load test one, two and three: same as for side door latches, longitudinal load, except that the test load must be applied in the directions specified in load tests one, two and three - Inertia loads: same as for side door latches

DOOR LOCKS AND RETENTION COMPONENTS FMVSS 206 AND ECE R.11.02

		<i>FMVSS 206</i>	<i>ECE R11.02</i>	<i>TECHNICAL DIFFERENCES IN REGULATIONS</i>	<i>DRAFT GLOBAL REGULATION</i>
6. TEST PROCEDURES (cont'd)					
6.3	SIDE DOOR HINGES				
6.3.1	SAE J934: - Attach a test fixture to the mounting provision of the hinge system, simulating vehicle position (door fully closed) relative to the hinge center line. - Distance between the extreme end of one hinge in the system to the extreme end of another hinge in the system: 16.00 in (406.4 mm). - Apply load equidistant between the linear center of the engaged portions of the hinged pins and through the center line of the hinge pin in the longitudinal vehicle direction (for longitudinal strength) and in the transverse vehicle direction (for transversal strength). - Apply test load at a rate ≤ 0.2 in (5 mm) per minute until failure. - Record maximum load	Test procedure: - position hinges on test fixture , closed door attitude - hinge pins shall be in straight line - distance between further ends of adjacent hinges: 406 mm. However, if 406 mm cannot be complied with, arrange hinges such that distance between the nearest parts of two adjacent hinges is at least 100 mm. - line joining mid points of the engaged portions of the two outermost hinge pins shall be bisected at right angles by the line of application of the tensile force. - longitudinal strength: longitudinal load perpendicular to axis of hinge pivots situated in a plane passing through that axis; stress the hinges in the vehicle longitudinal direction - transversal strength: transverse load perpendicular to plane defined by longitudinal load and axis of pivots and situated in a plane passing through the axis; stress the hinges in the vehicle transverse direction - apply load at rate ≤ 5 mm/min	ECE allows the 406 mm dimension to be changed Otherwise, no difference: see figure	- Attach a test fixture to the mounting provision of the hinge system, simulating vehicle position (door fully closed) relative to the hinge center line. - Distance between the extreme end of one hinge in the system to the extreme end of another hinge in the system: 406 mm. However, if 406 mm cannot be complied with, arrange hinges such that distance between the nearest parts of two adjacent hinges is at least 100 mm. - Apply load equidistant between the linear center of the engaged portions of the hinged pins and through the center line of the hinge pin in the longitudinal vehicle direction (for longitudinal strength) and in the transverse vehicle direction (for transversal strength). - Apply test load at a rate ≤ 0.2 in (5 mm) per minute until failure. - Record maximum load	
6.4	SIDE DOOR PIANO HINGES				
6.4.1	For piano type hinges, the hinge spacing requirements of SAE J934 shall not be applicable and arrangement of the test fixture shall be altered as required so that the test load will be applied to the complete hinge.	Full length piano hinges: - position hinges on test fixture , closed door attitude - longitudinal strength: line of application of the tensile force shall bisect at right angles the engaged portion of the hinge pin; tensile force in vehicle longitudinal direction. - transversal strength: engaged length of hinged pin shall be bisected at right angles by line of application of the tensile force; tensile force in vehicle transverse direction - apply load at rate ≤ 5 mm/min	ECE is more specific about piano hinge testing than FMVSS. However, no significant difference in practice	Full length piano hinges: - position hinges on test fixture , closed door attitude - longitudinal strength: line of application of the tensile force shall bisect at right angles the engaged portion of the hinge pin; tensile force in vehicle longitudinal direction. - transversal strength: engaged length of hinged pin shall be bisected at right angles by line of application of the tensile force; tensile force in vehicle transverse direction - apply load at rate ≤ 5 mm/min	

DOOR LOCKS AND RETENTION COMPONENTS FMVSS 206 AND ECE R.11.02

		<i>FMVSS 206</i>	<i>ECE R11.02</i>	<i>TECHNICAL DIFFERENCES IN REGULATIONS</i>	<i>DRAFT GLOBAL REGULATION</i>
6. TEST PROCEDURES (cont'd)					
6.5	BACK DOOR HINGES				
	6.5.1	Same as for side hinged doors except that the loads shall be in the directions specified in test load one, two and three described above. The same test device may be used for load tests two and three.	None	EU/ECE do not require testing of back doors	Same as for side hinged doors except that the loads shall be in the directions specified in test load one, two and three described above. The same test device may be used for load tests two and three.

DOOR LOCKS AND RETENTION COMPONENTS

FMVSS 206 AND ECE R.11.02

Test procedure for latches: longitudinal load

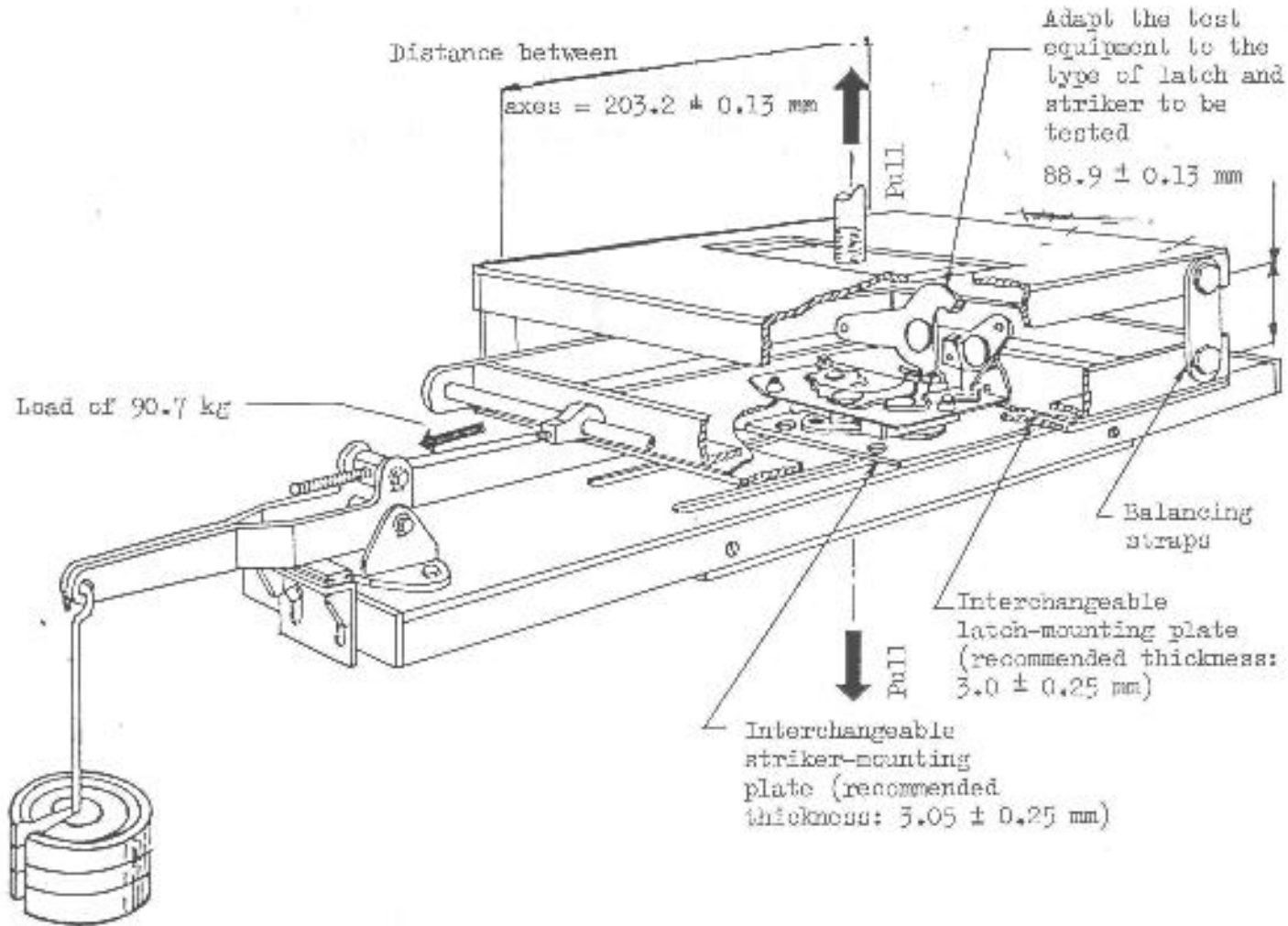

**DOOR LOCKS AND RETENTION COMPONENTS
FMVSS 206 AND ECE R.11.02**

Test procedure for latches: transversal load

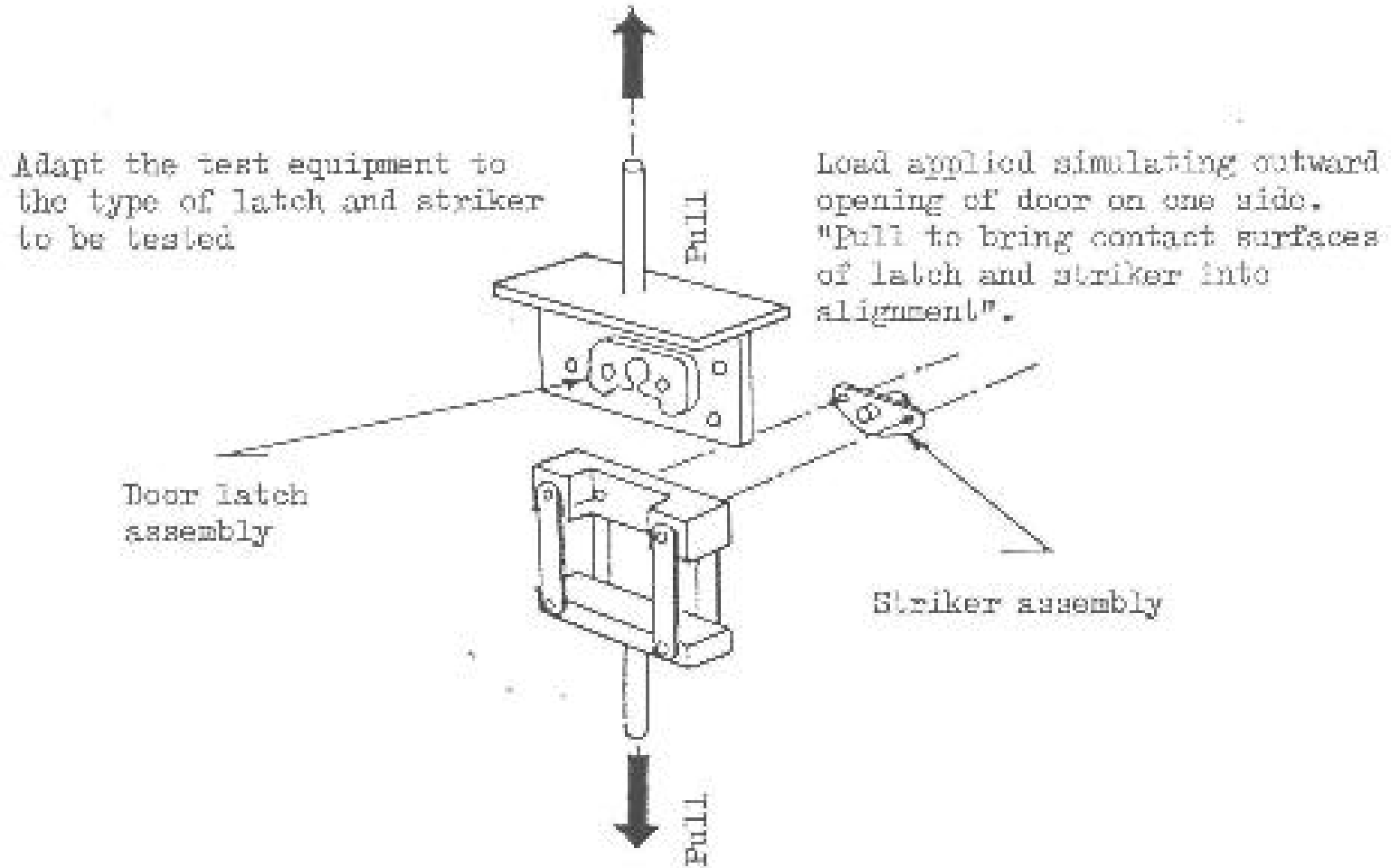

**DOOR LOCKS AND RETENTION COMPONENTS
FMVSS 206 AND ECE R.11.02**

Test procedure for hinges

