

UNITED NATIONS ECONOMIC COMMISSION FOR EUROPE



UN/CEFACT

Simple, Transparent and Effective Processes
For Global Commerce

REQUIREMENTS SPECIFICATION MAPPING (RSM)

Business Domain: Cross Industry – Supply Chain

Business Process: Catalogue Process

Title: Cross Industry Catalogue Information

UN/CEFACT International Trade and Business Processes Group: TBG1

Version: 1.00.04

Release: 1

Document Summary

Document Item	Current Value
Document Title	Requirements Specification Mapping Cross Industry Catalogue Information
Date Last Modified	12-May-2010
Current Document Version	1.00.04
Status	Draft
Document Description (one sentence summary)	Specification that describes the data model and targeted technology solutions for the catalogue information in the catalogue process.

Contributors

Name	Organization

Log of Changes

Issue No.	Date of Change	Changed By	Summary of Change
1.00.00	2-November-2009	TBG1	Provided the RSM in the format as required by ICG.
1.00.01	11-November-2009	TBG1	<ul style="list-style-type: none"> Commonly reused ABIEs included. Editorial corrections
1.00.02	21-Dec-2009	TBG1	Several changes based on the ICG Second Audit Pass report.
1.00.03	2-Feb-2010	TBG1	Several changes based on the ICG Third Audit Pass report.
1.00.04	12-May-2010	TBG 1	Complementary addition of a missing Basic Business Information Entity in section 7.1

TABLE OF CONTENTS

1. Preamble	4
2. References	4
3. Objective	4
4. Definition of terms.....	4
5. Target technology solutions	17
6. Information payload to be implemented	18
6.1. Conceptual Data Model for the Cross Industry Catalogue	18
6.2. Canonical Data Model for the Cross Industry Catalogue	19
6.2.1. Cross Industry Catalogue.....	20
6.2.2. Cross Industry Common	25
7. Business information entity reference.....	29
7.1. Basic Business Information Entities section	29
7.2. Aggregate Business Information Entities section	31
7.2.1. Message specific ABIEs.....	31
7.2.2. Common ABIEs	51
8. Core components UN/CEFACT Registry version used	116
9. Draft Core Component reference.....	116
10. Additional documentation	116
11. Additional information	116

1. Preamble

The current practice of exchanging business documents by means of telecommunications – usually defined as e-Business – presents a major opportunity to improve the competitiveness of companies, especially for Small and Medium Enterprises (SME).

The catalogue is an important document exchanged between trading partners, it marks the start of the trading cycle.

The developing of the Cross Industry Catalogue started as an initiative by CEN/ISSS Workshop eBES, the European Expert Group 1 (EEG1) – Supply Chain & e-Procurement.

The document describe globally consistent catalogue information exchange processes for worldwide supply chains and e-Procurement of commodities, using the UN/CEFACT Modelling Methodology (UMM) approach and Unified Modelling Language to describe the business processes and business documents involved.

The structure of this document is based on the structure of the UN/CEFACT Business Requirements Specification (BRS) document reference CEFACT/ICG/005.

Version 1.0 of the BRS was taken as the basis to develop the Requirements Specification Mapping (RSM) version 1.

The structure of this document is based on the structure of the UN/CEFACT Requirements Specification Mapping (RSM) – Documentation Template and Conformity Rules, document reference CEFACT/ICG/006.

2. References

- UN/CEFACT TBG1 Common Supply Chain BRS, Release 1
- UN/CEFACT TBG1 Cross Industry Catalogue Information BRS, Release 1

3. Objective

In conjunction with the BRS document (CEFACT/ICG/005), the purpose of this document is to provide a standard framework for the exchange of catalogue information.

4. Definition of terms

Term	Definition
Document Information	Information about the catalogue document.
Catalogue Identifier	The identifier of the catalogue collection assigned by the catalogue provider
Catalogue Request Reference	The reference to the request of the catalogue.
Catalogue Subscription Reference	The reference to the catalogue subscription.
Description	A general overall description of the catalogue.
Validity period	The period for which the catalogue or catalogue collection is valid.
Catalogue status code	Code giving the status of the catalogue.

Term	Definition
Catalogue update/replace, Reference	Reference to the updated or replaced catalogue .
Price List Reference	A reference to the price list for this catalogue.
Contract Reference	A reference to business contract which the catalogue is based upon.
Trading Terms	Trading terms and conditions that apply to all trade items in the catalogue
Catalogue Provider	The provider of the catalogue information.
Catalogue Receiver	The receiver of the catalogue information
Procurement Party	The party at the customer side responsible for negotiating the contract and the contents of the catalogue.
Supplier Party	Party who owns the item and consigns or makes them available in trade.
Delivery Date Period	The date period in which catalogue items may be delivered
Payment Instructions	The payment instructions applicable to the catalogue
Payment Terms	The payment term applicable to the catalogue
Target market	A geographical area based upon geographical boundaries sanctioned by the United Nations, in which the trade items mentioned in the catalogue are available.
Delivery Region, text	A medium-scale area of land to which the items mentioned in the catalogue can be delivered.
Delivery Location	A geographical location to which the items mentioned in the catalogue can be delivered.
Line Count Numeric	The number of lines in the catalogue.
Catalogue Item Identification	The identification of the catalogue item according to a cataloguing system
Catalogue item action code	The code specifying the action valid for the catalogue item.
Trade Item Grouping Code	A code assigned by the supplier or manufacturer to logically group trade items independently from classification systems.
Trade Item Grouping Name	The corresponding name in clear text for the grouping code of a trade item.
Catalogue item availability Code	Code indicating availability of the catalogue item
Catalogue Item Information Provider Party	The party who provides the catalogue item information.
Trade Item Shipping Period	Indicates the date period the catalogue item can be shipped.
Catalogue item information Validity period	The period during which the information provided for the catalogue item is valid.
Catalogue item information Change latest date time	The last date time the catalogue item data was changed
Multimedia presentation	Multimedia presentation of the item (e.g. picture or drawing)
Additional Information	A link to additional information on the item (e.g., the URL of a relevant web page).
Additional Information Note, text	Additional information in clear text about the item not already given as structured information To be used as non-structured information.

Term	Definition
Keyword, text	A text string or synonyms to be used for searching for the catalogue item.
Replacing Catalogue item	References to catalogue items that can replace or substitute the catalogue Item
Accessory Product	Relation to accessories or attachments to the catalogue Item e.g. headphones to a mobile phone
Required Product	Relation to a required product to the catalogue item e.g. a subscription to a mobile phone
Complementary Product	Relation to products that compliments the catalogue item e.g. coal for a barbecue
Component Product	Relation to components or parts to the product e.g. an ink cartridge for a printer
Additional Product relation	Relationship to other products other than replacing product, accessory product, required related product, complementary product and component product.
Catalogue Item Reorderable Indicator	The indicator indicating that the catalogue item may be reordered.
Tracking System Identifier	Identifies a system by which the product is being tracked.
Target market	A geographical area based upon geographical boundaries sanctioned by the United Nations, in which the catalogue items are available.
Tax Information	Information about all applicable taxes for the catalogue item
Trade Agreement	Information on trade agreements
Trade Delivery	Information on trade deliveries.
Product	Information on the product (trade item).
Tax Type Code	The code indicating the type of tax
Tax Type Description	Description of tax type code.
Tax Category Code	Code specifying a duty or tax or fee category
Tax exemption reason	Information about the reason for exemption of tax, coded or in clear text
Tax Rate Percentage	The percentage value of the tax rate when specified in percentage
Tax Rate Monetary amount	The monetary value of the tax rate when specified as a monetary amount (for a specified currency)
Tax location	A country or other geographical area to which a specific tax is applicable.
Tax Agency Code	A code identifying the (national) tax agency.
Reason for exemption, code	A code identifying the reason for tax exemption.
Reason for exemption, text	Reason for tax exemption in clear text.
Procurement Party	The party at the customer side responsible for negotiating the contract and the contents of the catalogue.
Supplier Party	Party who owns the product and consigns or makes them available in trade.

Term	Definition
Trading Terms	Trading terms and conditions which apply to all trade items. Trading terms can be given in text and/or as a reference to where the trading terms can be found (URL to national or industry specific terms).
Contract Reference	The reference to a contract.
Contract Subdivision text	A text giving a subdivision of a contract or tender.
Price Contract Reference	The reference to a contract specifying the price conditions.
Customer Support Centre - Party	The customer support centre for the catalogue item.
Restricted information indicator	The indicator to qualify that catalogue item information is restricted to specific use according to agreement.
Product Ordering Period	The period of date the catalogue item (product) can be ordered.
Product Exclusivity end date time	The date and time at which a catalogue item (product) no longer is exclusive to the trading partner
Availability To Consumer Start Date and Time	The first date/time the buyer is allowed to resell the catalogue item (product).
Product First Delivery Date	The earliest date at which the supplier can deliver the catalogue item (product) to the trading partner.
Minimum product lifespan from time of arrival, Days	A number of days from the arrival date, guaranteed by the manufacturer, before the expiration date of the product.
Orderable indicator	The indicator identifying that the catalogue item may be ordered.
Made to Order Indicator	Indicates that the item will only be produced when the manufacturer receives an order.
Trade Item Delivery Lead Time	The time taken from the time of order to the time of delivery for the item in a specific delivery quantity to a specific delivery location or region.
Catalogue Item Pick Up Lead Time	The earliest time an ordered catalogue item is available for pick up expressed as weeks, days, hours (etc).
Catalogue Item Order Incremental Quantity	The incremental quantity in which the product must be ordered e.g. 10 = orders of 10, 20, 30 etc.
Catalogue Item Minimum Order Quantity	The minimum quantity of the product which must be ordered
Catalogue Item Minimum Order Quantity Date Period	The date period for when the minimum order quantity is available for ordering.
Catalogue Item Maximum Order Quantity	The maximum quantity of the catalogue item available for ordering.
Catalogue Item Maximum Order Quantity Date Period	The date period for when the maximum order quantity is available for ordering .
Ordering Unit Of Measure	The unit of measure for the ordering of the catalogue item (product).
Selling Unit Of Measure	The unit of measure for the selling of the product to the end consumer.
Purchase Conditions	The conditions applying to the sale or purchase of the catalogue item
Warranty Information text	Warranty information in clear text about the catalogue item.
Price information	Price(s) information applied to the product.

Term	Definition
Delivery terms	The delivery terms and if relevant the location related to the delivery terms.
Marketing	Marketing information about the catalogue item
Price List Reference	A reference to a price list.
Catalogue Item Price amount	The price amount for the catalogue item.
Price Amount Type Code	The code for the price amount type.
Additional Price Amount Type Code	The code for an additional price amount type.
Price Basis Quantity	The quantity of the Item to which the applicable price applies.
Allowance Charge	Charges and discounts for the catalogue item
Price Change Reason Text	The reason for the price change expressed as text
Validity Period for Price	The period(s) for which the price is valid.
Bracket Price Quantity Range	The quantity range (minimum, maximum) of the item for which the price is valid.
Price Validity Location	A delivery location(s) for which the price is valid.
Price Comparison	Price comparison information of the product.
Price List Identifier	The identifier for the price list.
Validity Period	The period(s) for which the price list is valid.
Immediate Previous Price List Reference	A reference to a immediate previous price list.
Comparison Price Amount	The price for the comparison quantity of the trade item in respect to the price comparison type (code).
Price Comparison Quantity	The quantity used for price comparison.
Price Comparison Type Code	Code indicating how price comparison is made. (How to calculate the comparative price.)
Handling Instructions	The specific instructions for storage, transport or handling of the product.
Carrier Party	The party which provides transport services.
Production Batch Identification	An identification of the production batch of the product.
Import Classification Code List Type Code	A code indicating the import classification code list used for the trade item.
Import Classification Value	The used value from the according import classification code list for the trade item.
Product Identification	The identification(s) of the product.
Official regulations compliance code	A code indicating the product to be in compliance with specific applicable official regulations.
Consumer unit indicator	Indicator identifying the product as a consumer unit.
Despatch unit indicator	The indicator identifying that the product may serve as a dispatch (shipping) unit
Product Launch Cancellation date	The cancellation date of the launch of a product that was never and will never be manufactured, but may previously been presented to buyers.

Term	Definition
Manufacturer Party	The party who makes the product (not to imply a party who simply provides packaging of the product).
Product rights owner party	The party who owns the rights of the product.
Minimum product lifespan from time of production, Days	A number of days from the production date, guaranteed by the manufacturer, before the expiration date of the product.
Opened Product Lifespan, Days	The number of days remaining from the time of break opening of the packaging of the product until not good for consuming.
Product Discontinued date	The date on which the product is no longer produced.
Product Change latest date time	The latest date time on which the product data was changed.
Product Name Text	The name of the product which distinguish it from other products and if necessary to be used in trade messages such as order and invoice.
Product Functional Description Text	A description of the use of the product.
Product Description Short Text	A short description of the product which can be used on shelf edge and on receipts.
Model Name	The model name.
Additional Product Description Text	An additional description of the product.
Variant description Text	A description used to identify the variant of the product. Variants are the distinguishing characteristics that differentiate items with the same brand and size such as flavour, fragrance, taste.
Product Brand Name	The brand name of the product
Sub Brand Name	Second level of brand name for the product.
Descriptive Form Text	A description of the physical form or shape of the product. Used, for example, in pharmaceutical industry to indicate the formulation of the trade item. Defines the form the trade item takes and is distinct from the form of the packaging. Examples: paste, gel, powder
Product Quantity	The quantity of the content contained in the product (trade item) (incl measurement unit code according to UN/ECE recommendation 20 / UN/CEFACT code list 6411)
Quantity Of Product Contained In Inner Pack	Indicates the number of non-coded physical groupings (inner packs) of next lower level of the trade item.
Product Drained Weight	The weight of the product of the trade item when drained of its liquid.
Trade Item Variable Measure Indicator	Indicator identifying the trade item as a variable measure trade item. The content of the trade item vary about either weight, length or volume (or other)
Country of origin Code	The code for the country in which (where) the product has been produced or manufactured
Subdivision Country of Origin code	A code for subdivision of country of origin (state, province or region) in which the product has been produced or manufactured
Country of assembly	The country where the product is assembled.
Product Colour Code	A code for describing the colour of the product.
Product Colour Description	A clear text describing the colour of the product.

Term	Definition
Product Prepack Type Code	A code specifying if the content of the product is pre-packed or contains loose products.
Customer Configurable Code	A code indicating that the customer may configure the item.
Recyclable type code	A code specifying the recyclable sign marked on the product.
Product marked with Serial number Indicator	Indicate if a serial number is marked on the product.
Security tag type Code	A code indicating the type of security tag on the product.
Security tag location Code	A code specifying where the security tag is located on the product.
Product Unit	An association to actual instance(s) of the Product.
Hazardous information	The information regarding hazardous and dangerous characteristics of the product.
Package information	Information about how the product is packed e.g. package type.
Logistic unit information	The information about the configuration of the logistic unit (e.g pallet, roll cage) Only to be used when the product is packed in a logistic unit and that unit is not specified as a "product" and consequently has no unique identification (e.g a GTIN). (Equivalent info on logistic units with unique identification is found in the class "Hierarchy Information")
Hierarchy information	Description of product hierarchy, multi pack and product composed by more than one product.
Physical Dimensions	The physical dimensions of the product.
Property	A technical property of the product.
Product Class	Classification of the product.
Product Material	The material(s) of which the product is composed.
Product Information Representation Reference	A reference to another representation format for product information.
Identification of the product	An identifier for the product.
Used Product Identification System	The used system for identification of the product.
Identification Issuing Party	An association to the party issuing the item Identification.
Product Identification Issuing Party	An association to the party that issued the Item Identification.
Extended Identification of the product	An extended identifier for the item that identifies the item with specific properties, e.g., Item 123 = Chair / Item 123 Ext 45 = brown chair.
Identifying Physical Attribute	Physical attribute(s) of the product for additional identification of the product.
Identifying Measurement Dimension	Measurement(s) of the product for additional identification of the product.
Campaign	A specific campaign for marketing the product.
Additional Marketing Document Reference	The link (e.g. URL) to an additional document.
Product Range Name	A name, used by the brand owner, that span multiple consumer categories or uses.(E.g. Waist Watchers,).
Brand Owner Party	Name and identification of the party who owns the brand of the product.

Term	Definition
Product Organic Code	Indicates the code for organic status of a product or of one or more of its components used for marketing purpose.
Organic Claim Agency	Indication of the governing body that determines if products can claim to be organic for marketing purpose.
Health Claim Text	Free text field for any health claims according to regulations of the target market.
Trade Item_ Marketing Special Item Code	A code used for identifying specific items for promotional or special tracking purposes.
Trade Item Feature Benefit Text	Description in clear text to describe the key features or benefits of the product/trade item. Used e.g for display purposes.
Season period Date and Time	Indicates the period for a seasonal product.
Trade Item Marketing Message	Marketing message for a trade item to use towards the consumer.
Descriptive Size Text	An alphanumeric size factor of the product . IE Jumbo, Capri, Full Length, Maxi . (Multi language)
Applicable Season, text	Season(s) applicable to the item in clear text.
Season Parameter, code	Code indicating the season, in which the trade item is available, i.e. assignment to one of the following collection periods: spring/summer, autumn/ winter or all year around.
Consumer Age, text	The age of the targeted consumer age range for which the product has been designed in clear text.
Consumer Gender, text	The gender of the targeted consumer for which the trade item (product) has been designed. In clear text
Marketing Feature	A marketing feature of the product, such as target consumer group.
Product Marketing Campaign Name	The name of a marketing campaign of a product.
Product marketing campaign period	The period for the marketing campaign of a product.
Warranty Party	An association to the party providing warranty of the Item on the Catalogue Line
Warranty Validity Period	An association to the validity of the warranty of the Item on the Catalogue Line
Warranty Information text	Warranty information text about the catalogue item.
Product Material Area Weight	The measured area weight of the material.
Product Gross weight	The gross weight of the product (includes all packaging materials of the product)
Product Height	The height of the product. The vertical dimension from the lowest extremity to the highest extremity, including packaging. (At a pallet level the item Height will include the height of the pallet itself.)
Product depth	The depth of the product. Measured from front to back of the product.
Product width	The measurement from left to right of the product. Measurements are relative to how the customer normally views the trade item. Needs to be associated with a valid UoM.
Product diameter	The measurement of the diameter of the product at its largest point.
Stacking factor	The number of levels the item or package may be stacked
Maximum stacking weight	The maximum admissible weight that can be stacked on the item or package.

Term	Definition
Delivery to distribution centre temperature maximum	The permitted maximum temperature of the item or package on transport to the distribution centre.
Delivery to distribution centre temperature minimum	The permitted minimum temperature of the item or package on transport to the distribution centre.
Delivery to market temperature maximum	The permitted maximum temperature of the item or package during delivery to market
Delivery to market temperature minimum	The permitted minimum temperature of the item or package during delivery to market to market
Storage temperature maximum	The maximum temperature at which the item or package can be stored.
Storage temperature minimum	The minimum temperature at which the item or package can be stored.
Storage humidity maximum	The maximum humidity in percentages that the item or package should be stored in
Storage humidity minimum	The minimum humidity in percentages that the item or package should be stored in
Instruction text	Specific handling instructions in text format (e.g. lift requirements)
Dangerous goods regulation code	The code specifying a dangerous goods regulation.
Dangerous Goods Hazard Class	<p>An identification of the hazard class applicable to the dangerous substance or product as defined by the relevant regulation authority, such as the IMDG class number of the SOLAS convention of IMO or the ADR/RID class number of the road/rail environment.</p> <p>Describes the type of dangerousness.</p> <p>Dangerous goods classification of the trade item. There are 9 danger classes, some classes are further subdivided into subclasses. "Class" number explains in general terms the nature and properties of the goods and serves to classify them together in terms of their most significant risk.</p>
Dangerous Goods Packing Group	Identifies the degree of risk the dangerous goods present during transport according to IATA/IMDG/ADR/RID regulations.
Dangerous Goods Hazardous Code Identifier	Dangerous goods hazard ID number, which must be applied to the vehicle, when transporting this trade item (dangerous good) by road or rail, to inform the police, the fire brigade and others in case of an accident about the kind of danger caused by the cargo.
Dangerous Goods AMargin Number	Code indicating whether facilitations for the transport of defined limited quantity by road or rail are possible or not. (code according to ADR)
Dangerous goods regulation name	The name of the dangerous substance or product as provided in the list of dangerous goods regulations.
Dangerous goods technical name	Provides the details of hazardous information. Chemical term of the trade item, listed by name and allowed in the substance list of GGVS (Dangerous Goods Ordinance for Roads) or GGVE (Dangerous Goods Ordinance for Rail). The name by which as dangerous substance or product may be correctly identified or which is sufficient information to permit identification by reference to generally available literature.

Term	Definition
Dangerous Goods Shipping Name	Shipping name of the trade item (dangerous goods). The recognized agencies (see dangerousGoodsRegulationsCodes), in their regulations, provide a list of all acceptable proper shipping names.
United Nations Dangerous goods (UNDG) Identification	The four-digit number assigned by the United Nations Committee of Experts on the Transport of Dangerous Goods to classify a substance or a particular group of substances. Abbreviation: UNDG Number.
Flash point temperature	The lowest temperature at which a substance gives off a sufficient vapor to support combustion.
Material Safety Data Sheet Reference	The identity of a Material Safety Data Sheet for the product
Hazardous information contact	Party to be contacted with relation to the product hazardous information
Number (quantity) of different products contained in a mixed product	The number (quantity) of different unique products contained in a mixed product. A mixed product may contain 2 or more different products.
Product Total Quantity	Total quantity of products that this product contains.
Next lower product level information.	Information on next lower product level.
Product Identification of a product contained in a product	The unique identification of the product contained in an identified product.
Quantity Of Products contained in a product	The quantity of products contained in the product
Item identification	The identification of the related catalogue item.
Relation type	The code specifying the type of relation between items
Related item quantity	The quantity of related catalogue items, e.g. next lower level item that this item contains.
Additional Information	A textual description of or other information about the relation.
Type	The type of Marketing Feature.
Type description	The description of the type of Marketing Feature.
Definition	The definition of the type of Marketing Feature.
Coded value	The coded value(s) of the marketing feature.
Text value	The textual value(s) of the marketing feature.
Measurement	Measured value(s) of the marketing feature.
Barcode type marked on package, code	The type of bar code or codes, which are visible on the product or package.
Expiration date type marked on package, code	A code specifying the type of expiration date of the product marked on the product.
Package/Product Marked With Batch number Indicator	Indicate if the product/package is marked with a batch number.
Package marked with Retail price Indicator	The indication of whether there is a retail price of the product physically on or attached to the package
Package Marked With Ingredients Indicator	Indicates if the package is marked with ingredients.
Package Marked With Net Content Indicator	Indicates if the package is marked with net content.

Term	Definition
Package Marked Returnable Indicator	Indicates if the package is marked as returnable.
Retail price Marked on Package	A retail price of the product as marked on the package.
Offer Text marked on package, text	A text about an offer marked on the package.
Package Marks containment Code	The code (s) marked on package stating whether or not the product contains or is free from a specific substance.
Package Marks containment Code	The code (s) marked on package stating whether or not the product contains or is free from a specific substance.
Package Marks With Diet Allergen Code	The code (s) marked on the package indicating dietary or allergen information.
Package Marked With Ethical Code	Code of which ethical trading marks that are on the package.
Package Marked With Environment Code	Code of which environmental marks that are on trade item package.
Logistic unit package type code	The code specifying the package type of the logistic unit.
Quantity of product per logistic unit	The quantity of product contained in the logistic unit
Quantity Of Layers of the logistic unit	The quantity of layers for the logistic unit
Quantity Of Product Per Layer of the logistic unit	The quantity of products contained on a single layer of the logistic unit.
Package type code	The code identifying the type of package
Indicator Returnable package/asset	The package of the product is returnable. This is a yes/no (Boolean) where yes equals package can be returned. Attribute applies to returnable package with or without deposit.
Returnable package/asset Deposit value start date	The first date that the deposit value of the returnable package/asset is valid.
Returnable package/asset Deposit value end date	The last date that the deposit value of the returnable package/asset is valid.
Returnable package/asset deposit amount	The monetary amount of the deposit for the individual returnable asset
Returnable package/asset deposit code	The code specifying the returnable package/asset deposit..
Number of items per width	The number of items that are packaged beside each other in the package in the width direction (e.g. on the shelf side facing the consumer).
Quantity Of products (Trade Items) Contained In A Complete Layer	Number of packages in one layer in the product (trade item). Required if the product (trade item) is a pallet.
Returnable package/asset terms and conditions	The coded or textual description of the returnable package/asset terms and conditions, e.g. rented, exchangeable, returnable asset against deposit).
Marks and labels	The marks and labels provided on the package
Packaging information	Information about the packaging for the package.
Recyclable scheme (s) for the packaging, text	The textual description of the scheme(s) under which the packaging is recyclable.
Recyclable type	The code specifying the recyclable type for the packaging marked on the product.
Packaging material	Information about the material composition of the packaging
Packaging Material code	The code detailing the package material for the packaging.

Term	Definition
Packaging Material Code List Maintenance Agency Text	A code identifying the agency that is maintaining packaging material codes.
Packaging Material percentage	A percentage of the specified material in the packaging.
Packaging Material Weight	A weight of the specified material in the packaging
Packaging Material description	The textual description of the packaging material.
Property	A technical property of the material from which the packaging is composed.
Product Material code	The code detailing the material within the product.
Product Material Agency Code	A code identifying the agency that is maintaining product material codes.
Product Material percentage	A percentage of the material in the product.
Product Material Quantity	A measured quantity of material in the product
Product Material description	The textual description of the product material.
Property	A technical property of the material from which the product is composed.
Product Unit Individual Identification	An identity for the product unit (individual item)
Manufacture DateTime	The date (and time) of manufacture of the Item Instance e.g manufacture date for a used car (second hand).
Registration Identification	The registration identifier of the Item Instance.
Product Instance Serial Number	The serial number of the product instance.
Production Batch Identification	An identification of the production batch of the product.
International Codification Designation, ICD	The ISO-specified data element used to uniquely identify a registration scheme. (ISO/IEC 6523-1)
Organisation Identification, OI	The identifier assigned to an organization within a registration scheme, and unique within that scheme.
Organisation Particular Department Identification, OPI	The identifier allocated to a particular department, service or other entity within an organization
Source of Organisation Particular Identification, OPIS	The data element used to specify the source for the organization part identifier.(ISO/IEC 6523-1)
Number of ISO standard Reference	For referencing standards, here the standard number will be given (e.g. 61360 for the IEC 61360)
ISO standard Part Reference	For referencing standards, here the part of the standard will be given (e.g. 2 for the Part 2 of IEC 61360)
ISO standard Edition Reference	Edition of the ISO standard
Class Code	Gives the identification of the class in the context of the classification / ontology
Class Version Reference	A reference to the version of the class
Property	Used for further specification of product class for the product i.e. GS1 GPC
International Codification Designation, ICD	The ISO-specified data element used to uniquely identify a registration scheme. (ISO/IEC 6523-1)
Organisation Identification, OI	The identifier assigned to an organization within a registration scheme, and unique within that scheme.

Term	Definition
Organisation Particular Department Identification, OPI	The identifier allocated to a particular department, service or other entity within an organization
Source of Organisation Particular Identification, OPIS	The data element used to specify the source for the organization part identifier.(ISO/IEC 6523-1)
Number of ISO standard, Reference	For referencing standards, here the standard number will be given (e.g. 61360 for the IEC 61360)
ISO standard Part Reference	For referencing standards, here the part of the standard will be given (e.g. 2 for the Part 2 of IEC 61360)
ISO standard Edition Reference	Edition of the ISO standard
Property Code	Coded representation of the property
Further Categorization Indicator	The indicator indicating that the product is further categorized.
Version of class	The version of the class
Technical property Type, code	The code specifying the type of technical property
Technical property Type, Text	The textual description of the type of property.
Property Value Text	The value of the property expressed as a textual description.
Property Value Code	The value of the property expressed as a code
Property Value Indicator	The value of the property expressed as an indicator.
Property Value Date Time	The value of the property expressed as a date time.
Property Value Binary	The value of the property expressed in a binary format.
Property Relation Information Text	A textual description of or other information on property relations.
Property definition Reference	The reference to a document, e.g. an ontology or standard, in which the property has been defined
Product Class	The product class that forms the context in which the property is defined.
Property Relation	Related property. E.g. a Voltage at a certain Temperature.
Property Value Quantity	The value of the property expressed as a quantity (measurement) (including unit of measure, UN/ECE rec 20)
Product Specification Document Reference	An associative reference to a document providing product specification information
Code for format for document providing product specification information	A code giving the format of a document providing product specification information.
Lead time	The time taken from the time of order to the time of delivery
Minimum Order quantity	Minimum order quantity for a specific lead time
Maximum Order quantity	Maximum order quantity for a specific lead time
Delivery Location	delivery locations or areas for items
Delivery Region	delivery regions for items

5. Target technology solutions

The Cross Industry Catalogue v1 solution requires a UN/CEFACT XML standard schema.

The Cross Industry Catalogue v1 solution will not be implemented as a UN/EDIFACT standard message.

6. Information payload to be implemented

6.1. Conceptual Data Model for the Cross Industry Catalogue

Figure 6-1 Business message model

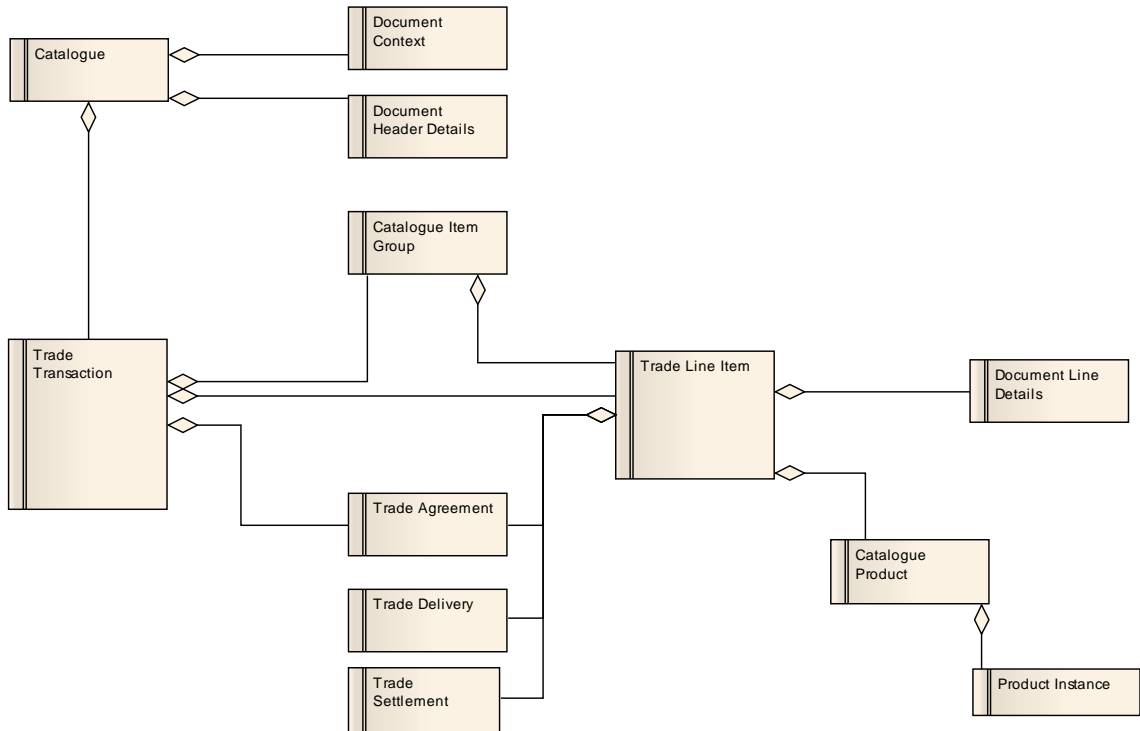

Philosophy behind the conceptual design

The conceptual design is based on the assumption that information exchanged in the order-to-pay (including the establishing of business agreements) process tends to have a large degree of similarity. Therefore rather than linking the information to message specific entities three neutral entities have been defined: Trade Agreement, Trade Delivery and Trade Settlement. These entities contain the main semantic payload for all communication exchanges, on header as well as on line level.

A fourth essential entity is the Product entity. This entity holds all characteristics of the trade product that are independent of a particular trade transaction.

The Trade Transaction and Trade Line Item entities serve to structure the entities mentioned before.

Description of the main entities

- Document Context: Application processing information for the business document.
- Document Header Details: Generic document heading information such as Catalogue identity and Issue date.
- Trade Transaction: Information on the trade transaction(s) to which the catalogue applies.
- Trade Line Item: Information on the line items contained in the catalogue.

- Catalogue Item Group: Information on grouping of trade line items.
- Document Line Details: Information on document line level such as line number.
- Trade Agreement: information on the commercial agreement on which the catalogue and trade transaction or catalogue line is based.
- Trade Delivery: information on the fulfillment of trade deliveries such as handling instructions.
- Trade Settlement: information on fulfillment of the financial settlements for a catalogue item such as tax information.
- Catalogue Product: Information on the product that is included in the catalogue.
- Product Instance: Information on the individual instances (objects) of a product.

6.2. Canonical Data Model for the Cross Industry Catalogue

For readability reasons the canonical model is provided in multiple diagrams, each providing a full description of a segment in the Cross Industry Catalogue.



Note: The three entities Trade Agreement, Trade Delivery and Trade Settlement have been depicted as identical on header and line level, since these entities are meant to support the entire Order-to-Pay process. In the individual steps of the process, such as the Catalogue, further refinements can be made on what is communicated on header and line level. Therefore in the canonical model for the Catalogue message the three conceptual entities are realized as six message specific entities, one for the header and one for the line.

6.2.1. Cross Industry Catalogue

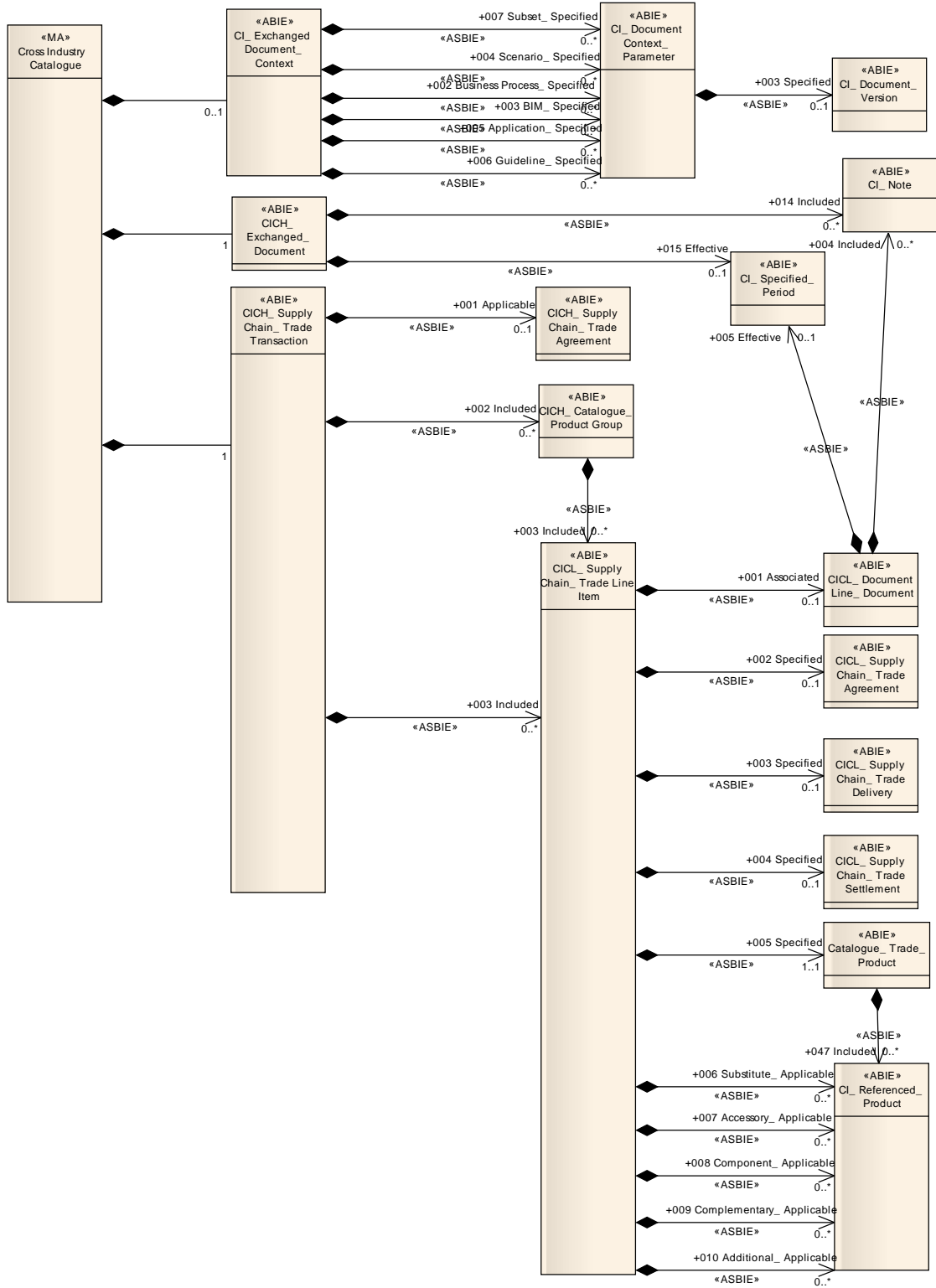

6.2.1.1. CICH Trade Agreement

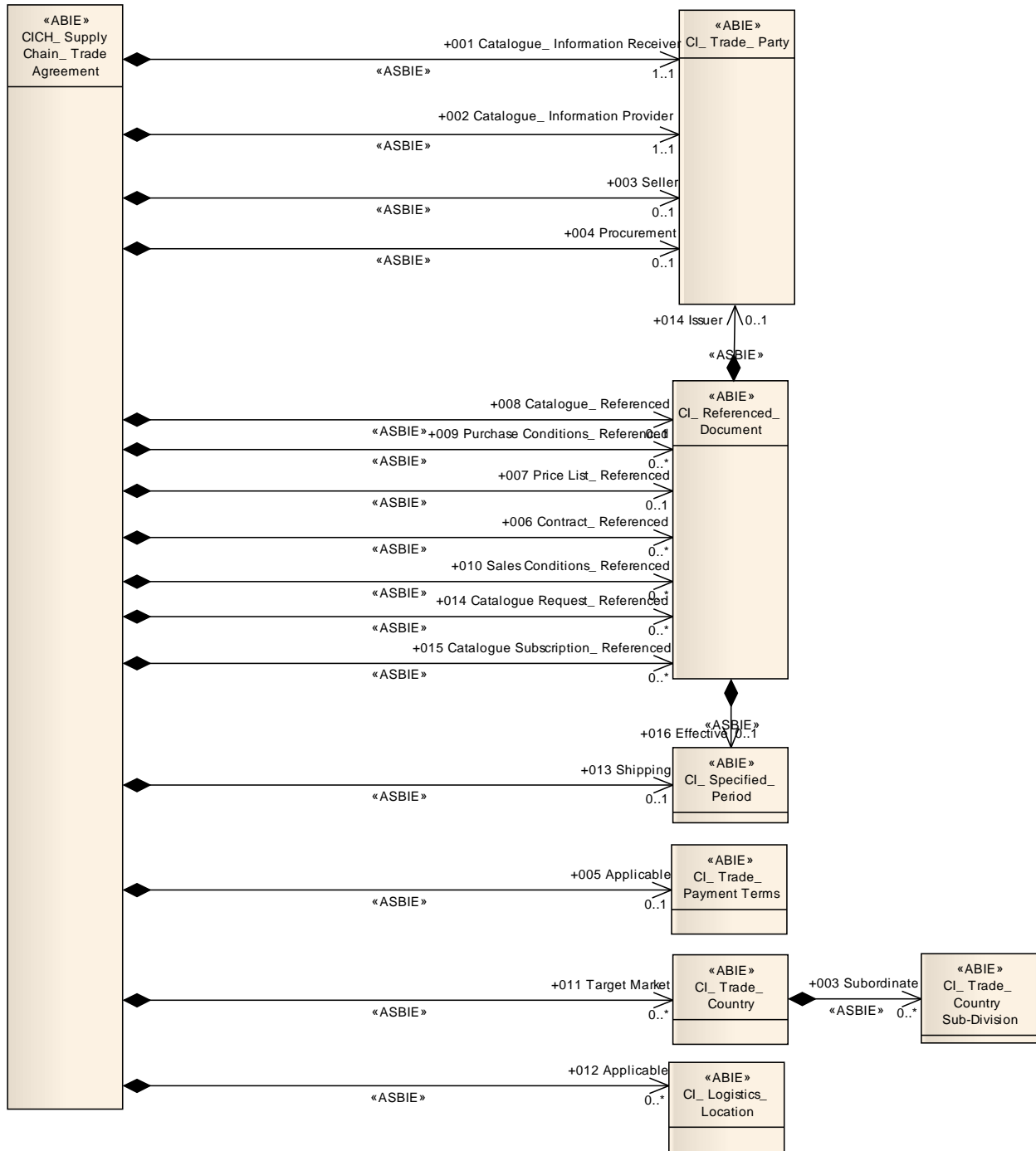

6.2.1.2. CICL Trade Agreement

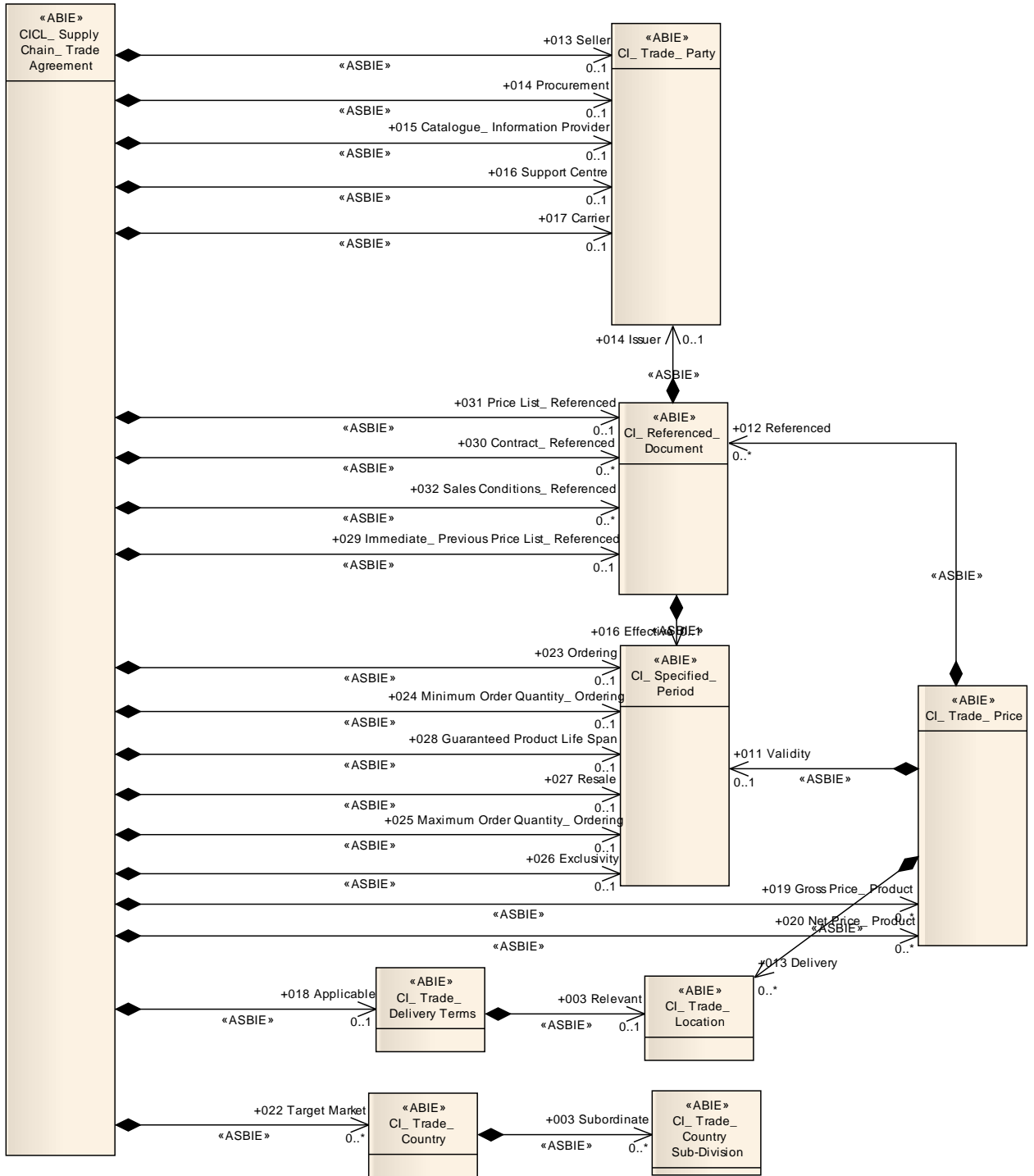

6.2.1.3. CICL Trade Delivery

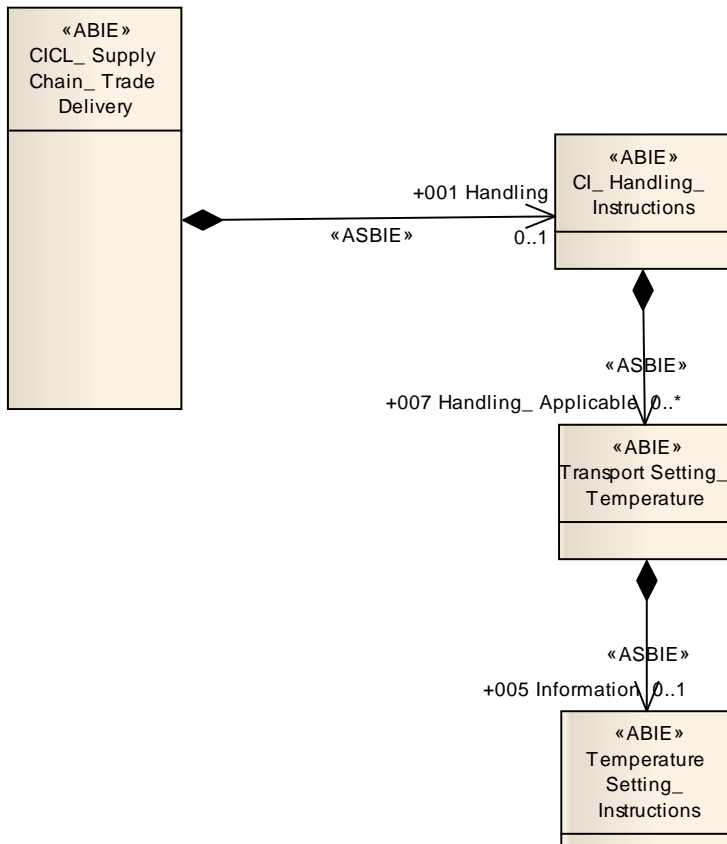

6.2.1.4. CICL Trade Settlement

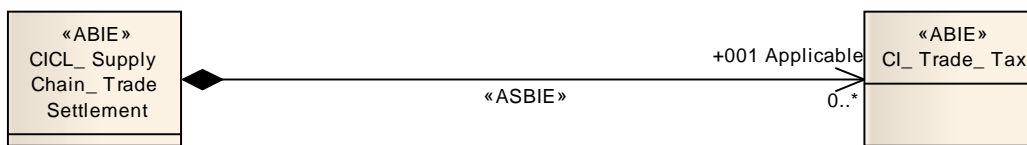

6.2.1.5. Catalogue Trade Product

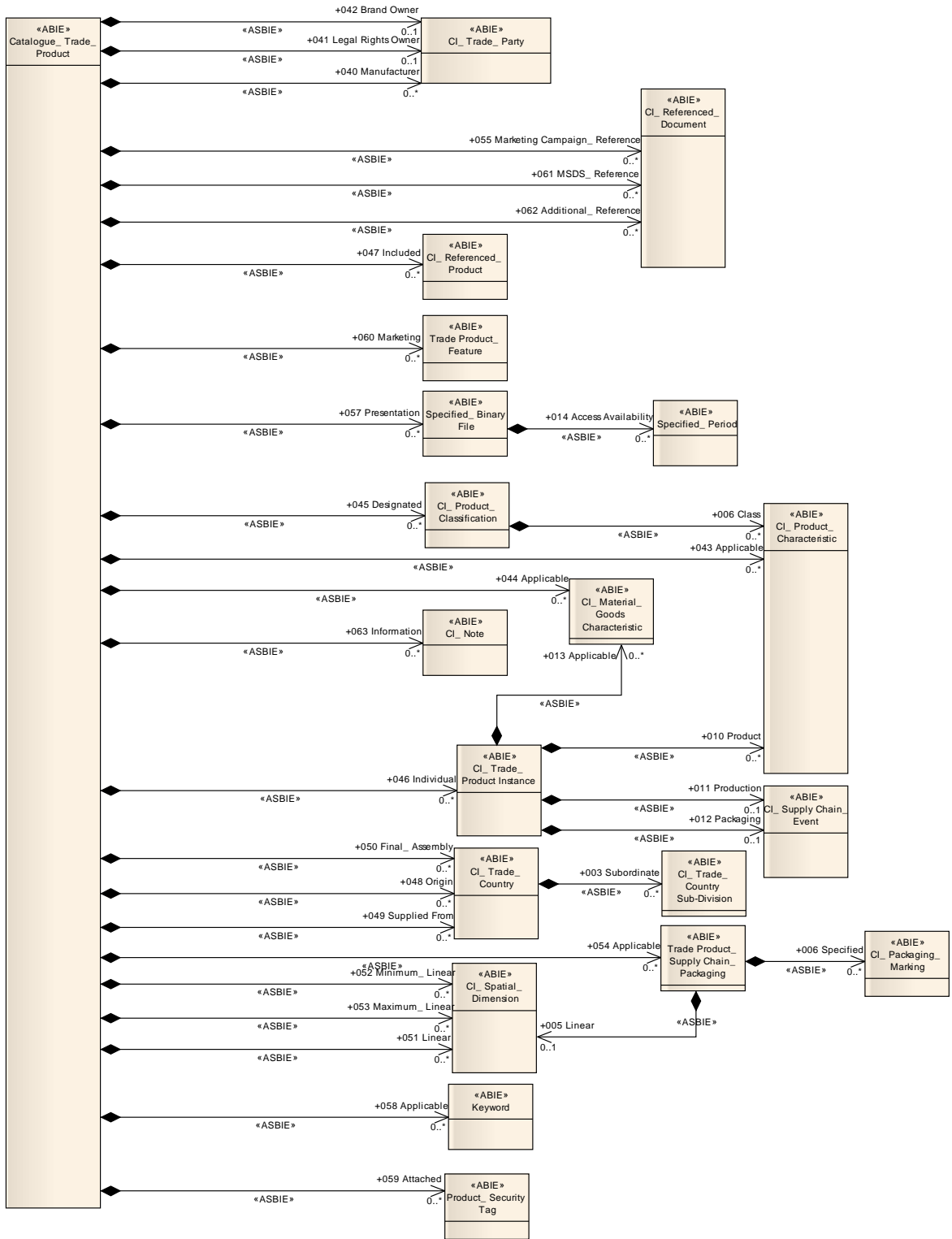

6.2.2. Cross Industry Common

6.2.2.1. CI Trade Price, CI Trade Allowance Charge, CI Trade Tax

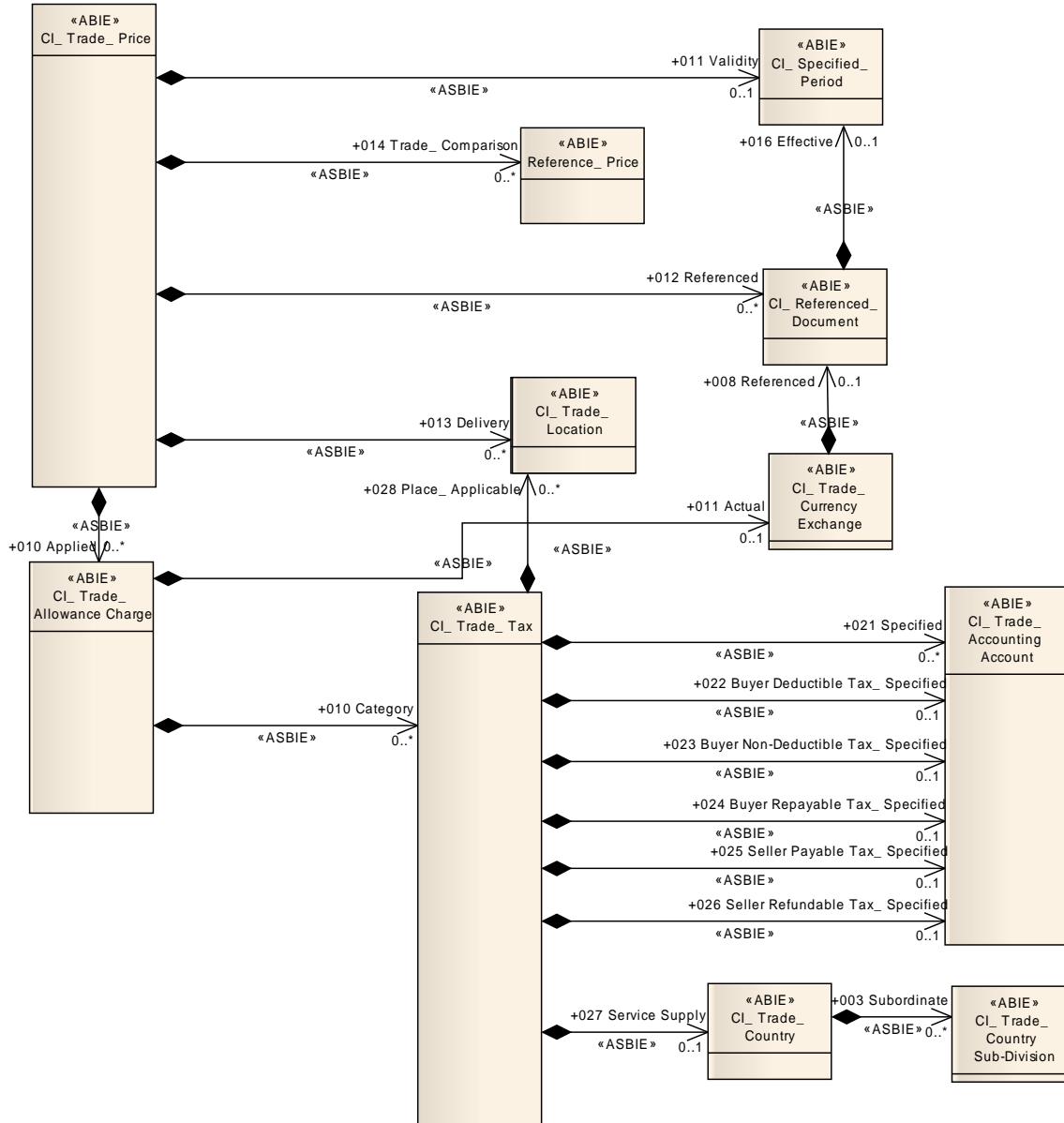

6.2.2.2. CI Referenced Document, CI Trade Party

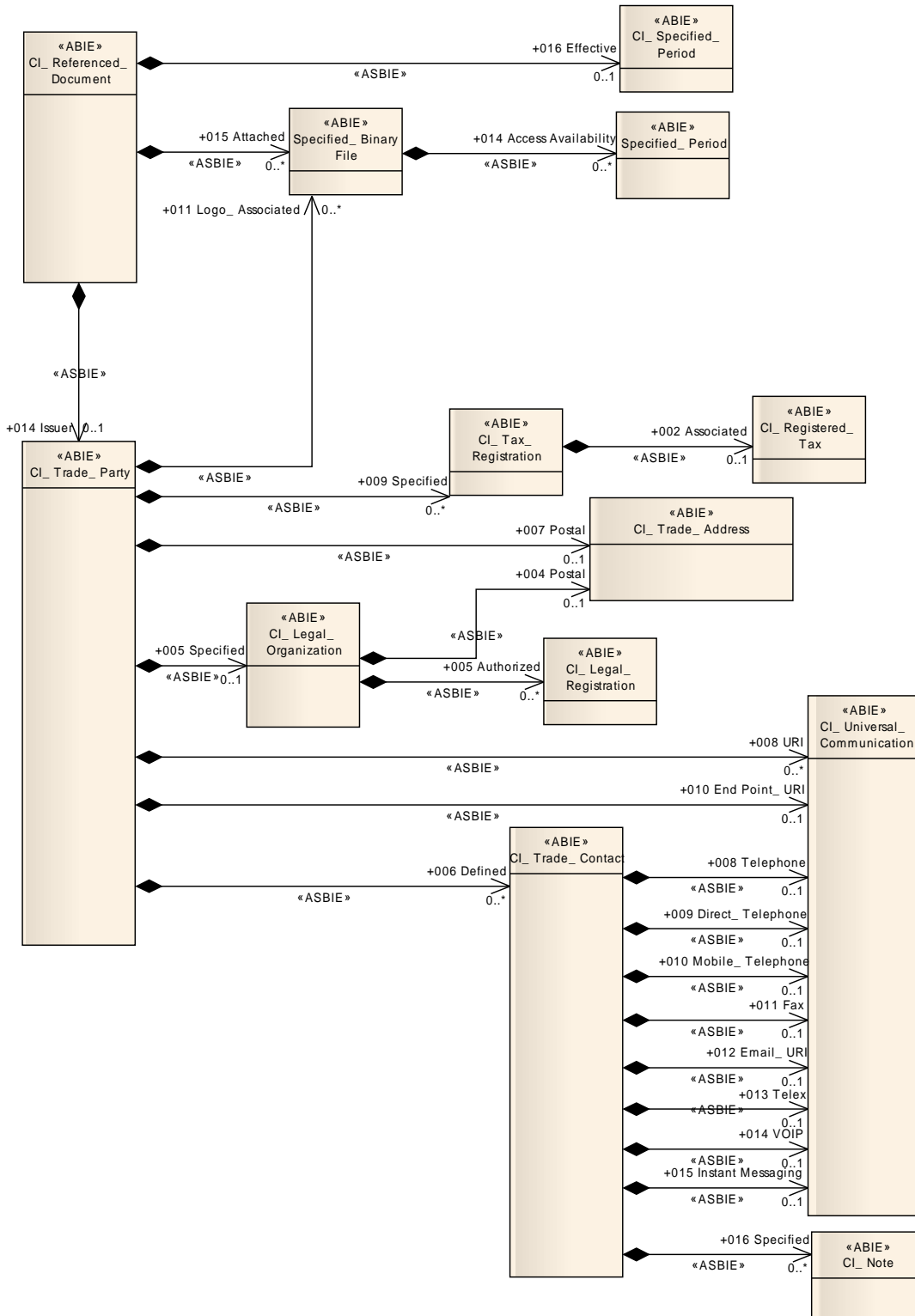

6.2.2.3. CI Trade Payment Means, Payment Terms

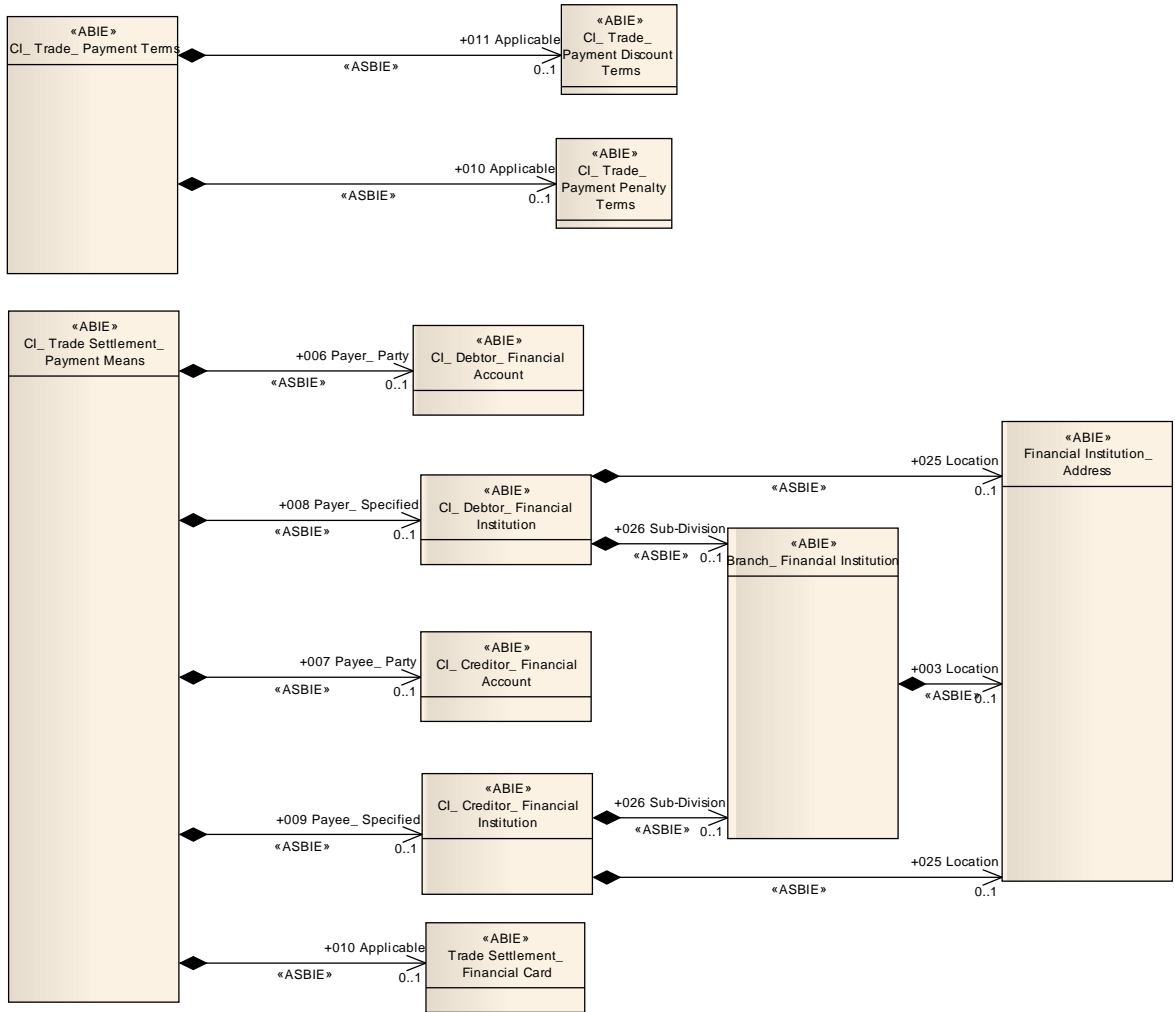

6.2.2.4. CI Supply Chain Event, CI Logistics Location

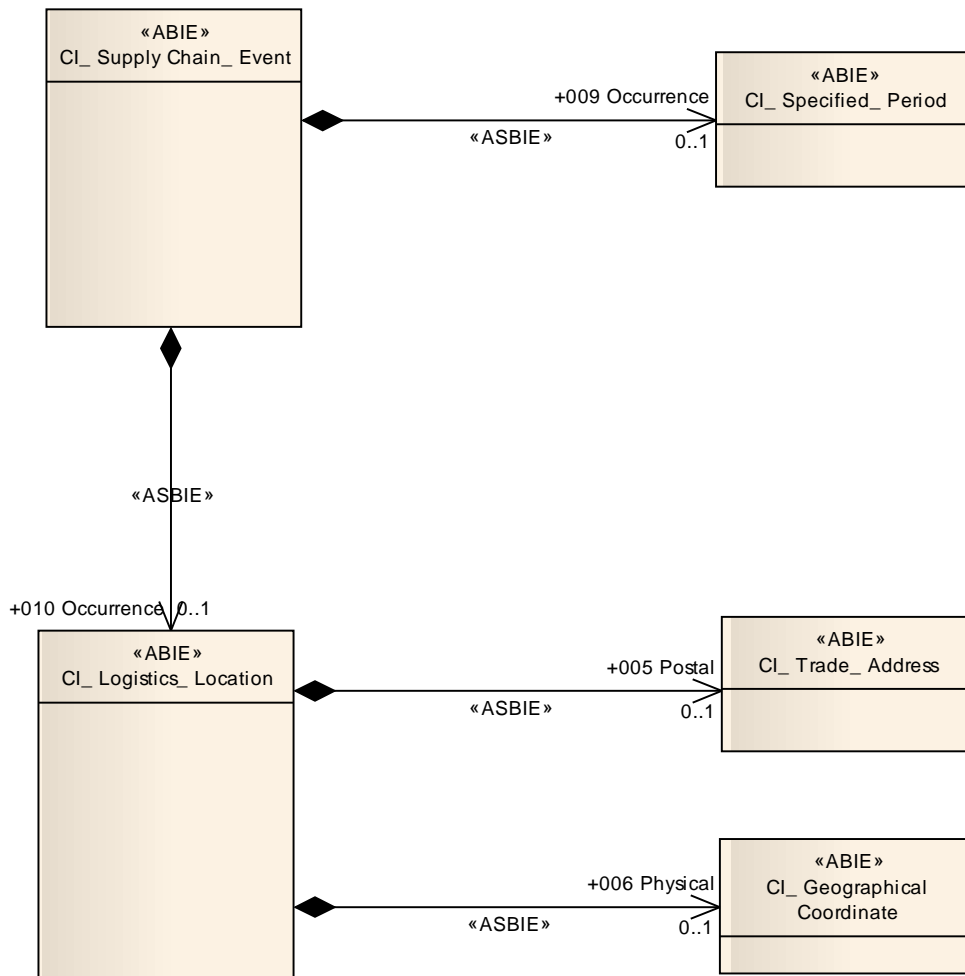

7. Business information entity reference

This section contains the list of all the Business Information Entities that are both used within the canonical data model and are variations from the standard Core Components, including the UN/CEFACT Registry version that served as the reference point.

7.1. Basic Business Information Entities section

This section identifies any restrictions that have to be applied to the BBIE in the context in which it is being used.

BBIE Dictionary Entry Name	Qualified Data Type	Core Component DEN	CC Restriction Type (CII specific only)	CC Restriction (CII specific only)	SC Restriction Type (CII specific only)	SC Restrictions (CII specific only)	UNCL TDED
CIH_ Exchanged_ Document. Type. Code	Document	Document. Type. Code	Enumeration	UNCL 1001 list	None	None	1001
CI_ Trade_ Party. Role. Code	Party Role_ Code	Party. Role. Code	Enumeration	UNCL 3035 list	None	None	3035
CI_ Referenced_ Document. Reference_ Type. Code	Reference _ Code	Document. Type. Code	Enumeration	UNCL 1153 list	None	None	1153
CI_ Trade_ Delivery Terms. Delivery Type. Code	Delivery Terms	Delivery Terms. Delivery Type. Code	Enumeration	UNCL 4053 list	None	None	4053
CI_ Trade_ Price. Type. Code	Price Type	Price. Type. Code	Enumeration	UNCL 5375 list	None	None	5375
CI_ Trade_ Allowance Charge. Reason. Code	Adjustment Reason	Allowance Charge. Reason. Code	Enumeration	UNCL 4465 list	None	None	4465
CI_ Trade_ Currency Exchange. Source Currency. Code	Currency	Currency Exchange. Source Currency. Code	Enumeration	UNCL 6345 list	None	None	6345

BBIE Dictionary Entry Name	Qualified Data Type	Core Component DEN	CC Restriction Type (CII specific only)	CC Restriction (CII specific only)	SC Restriction Type (CII specific only)	SC Restrictions (CII specific only)	UNCL TDED
CI_Trade_Currency Exchange. Target Currency. Code	Currency	Currency Exchange. Target Currency. Code	Enumeration	UNCL 6345 list	None	None	6345
CI_Trade_Location. Country. Identifier	Country	Location. Country. Identifier	Enumeration	UNCL 3207 list	None	None	3207
CI_Trade_Tax. Type. Code	Tax Type	Tax. Type. Code	Enumeration	UNCL 5153 list	None	None	5153
CI_Trade_Tax. Currency. Code	Currency	Tax. Currency. Code	Enumeration	UNCL 6345 list	None	None	6345
CI_Spatial_Dimension. Type. Code	Dimension Type	Dimension. Type. Code	Enumeration	UNCL 6145 list	None	None	6145
CI_Referenced_Document. Issue. Date Time	Date Mandatory	Document. Issue. Date Time	None	None	None	None	2007
CI_Trade_Payment Terms. Identification. Identifier	Payment Terms	Payment Terms. Identification. Identifier	Enumeration	UNCL 4277 list	None	None	4277
CI_Trade_Payment Terms. From Event. Code	Payment Terms Event_ Time Reference	Payment Terms. From Event. Code	Enumeration	5 Date of invoice 24 Date ex-works 29 Date of delivery 45 Date of transport contract document 71 Date of presentation of documents	None	None	2475
CI_Handling_Instructions. Handling_ Applicable. Transport Setting_ Temperature. Value. Measure	Temperature	Measure Unit. Code	Enumeration	UNECE Recommendation 20 (UNCL 6411 list)	None	None	6411

7.2. Aggregate Business Information Entities section

7.2.1. Message specific ABIEs

Occurrence	Element/Attribute
0 .. 1	CI_ Exchanged Document_ Context. Details <i>CI_ Exchanged Document_ Context. Specified_ Transaction. Identifier</i> Business Requirement 07/11/2008 CSC DOC0014 0..1 Transaction Type ID (i.e. Guideline Transaction type ID)
0 .. unbounded	CI_ Exchanged Document_ Context. Business Process_ Specified. CI_ Document Context_ Parameter Main::CI_ Document Context_ Parameter. Details
0 .. 1	<i>CI_ Document Context_ Parameter. Identification. Identifier</i> Business Requirement 07/11/2008 CSC DOC0012 0..1 Version ID (standard i.e. BRS and/or BIM)
0 .. 1	<i>CI_ Document Context_ Parameter. Value. Text</i>
0 .. unbounded	CI_ Exchanged Document_ Context. BIM_ Specified. CI_ Document Context_ Parameter Main::CI_ Document Context_ Parameter. Details
0 .. 1	<i>CI_ Document Context_ Parameter. Identification. Identifier</i> Business Requirement 07/11/2008 CSC DOC0012 0..1 Version ID (standard i.e. BRS and/or BIM)
0 .. 1	<i>CI_ Document Context_ Parameter. Value. Text</i>
0 .. unbounded	CI_ Exchanged Document_ Context. Scenario_ Specified. CI_ Document Context_ Parameter Main::CI_ Document Context_ Parameter. Details
0 .. unbounded	CI_ Exchanged Document_ Context. Application_ Specified. CI_ Document Context_ Parameter Main::CI_ Document Context_ Parameter. Details
0 .. unbounded	CI_ Exchanged Document_ Context. Guideline_ Specified. CI_ Document Context_ Parameter Main::CI_ Document Context_ Parameter. Details
0 .. 1	<i>CI_ Document Context_ Parameter. Identification. Identifier</i> Business Requirement 07/11/2008 CSC DOC0013 0..1 Version ID (standard i.e. Subset guideline)
0 .. 1	<i>CI_ Document Context_ Parameter. Value. Text</i>
0 .. unbounded	CI_ Exchanged Document_ Context. Subset_ Specified. CI_ Document Context_ Parameter Main::CI_ Document Context_ Parameter. Details

Occurrence	Element/Attribute
CICH_ Exchanged_ Document. Details	
	Business Requirement
1 .. 1	12/07/2009 Catalogue CAT0001 1..1 Document Information
	— CICH_ Exchanged_ Document. Identification. Identifier
	Business Requirement
0 .. unbounded	12/07/2009 Catalogue CAT0002 1..1 Catalogue Identifier
	— CICH_ Exchanged_ Document. Name. Text
	Business Requirement
0 .. 1	12/07/2008 CSC DOC0003 0..1 Document Name
	— CICH_ Exchanged_ Document. Type. Code
	Business Requirement
0 .. 1	08/09/2008 CSC DOC0018 0..1 Document Type Code
	— CICH_ Exchanged_ Document. Issue. Date Time
	Business Requirement
0 .. 1	12/07/2008 CSC DOC0002 1..1 Issue Date Time - Option needed to have
	— CICH_ Exchanged_ Document. Copy. Indicator
	Business Requirement
0 .. unbounded	12/07/2008 CSC DOC0008 0..1 Copy Indicator
	— CICH_ Exchanged_ Document. Language. Identifier
	Business Requirement
0 .. 1	12/07/2008 CSC DOC0010 0..1 Document Language
	— CICH_ Exchanged_ Document. Line Count. Numeric
	Business Requirement
1 .. 1	12/07/2009 Catalogue CAT0022 0..1 Line count
	— CICH_ Exchanged_ Document. Purpose. Code
	Business Requirement
0 .. 1	12/07/2009 Catalogue CAT0008 1..1 Catalogue status code
	— CICH_ Exchanged_ Document. Revision. Date Time
	Business Requirement
0 .. 1	12/07/2008 CSC DOC0005 0..1 Revision Date Time
	— CICH_ Exchanged_ Document. Global_ Identification. Identifier
	Business Requirement
0 .. 1	12/07/2008 CSC DOC0004 0..1 Universally unique identifier
	— CICH_ Exchanged_ Document. Revision_ Identification. Identifier
	Business Requirement
0 .. 1	12/07/2008 CSC DOC0006 0..1 Index ID - mapped to Revision which refers
	— CICH_ Exchanged_ Document. Previous Revision_ Identification. Identifier
	Business Requirement
0 .. unbounded	12/07/2008 CSC DOC0007 0..1 Previous Index ID - mapped to Revision
	— CICH_ Exchanged_ Document. Included. CI_ Note
	Main::CI_ Note. Details
	Business Requirement
0 .. 1	12/07/2009 Catalogue CAT0005 0..* Description
	— CICH_ Exchanged_ Document. Effective. CI_ Specified_ Period
	Main::CI_ Specified_ Period. Details
	Business Requirement
	12/07/2009 Catalogue CAT0007 0..1 Validity period

Occurrence	Element/Attribute
	CICH_Supply Chain_Trade Transaction. Details
0 .. 1	CICH_Supply Chain_Trade Transaction. Applicable. CICH_Supply Chain_Trade Agreement Main::CICH_Supply Chain_Trade Agreement. Details
1 .. 1	CICH_Supply Chain_Trade Agreement. Catalogue_Information Receiver. CI_Trade_Party Main::CI_Trade_Party. Details
	Business Requirement 12/07/2009 Catalogue CAT0013 1..1 Catalogue Receiver
1 .. 1	CICH_Supply Chain_Trade Agreement. Catalogue_Information Provider. CI_Trade_Party Main::CI_Trade_Party. Details
	Business Requirement 12/07/2009 Catalogue CAT0012 1..1 Catalogue Provider
0 .. 1	CICH_Supply Chain_Trade Agreement. Seller. CI_Trade_Party Main::CI_Trade_Party. Details
	Business Requirement 12/07/2009 Catalogue CAT0015 0..1 Supplier
0 .. 1	CICH_Supply Chain_Trade Agreement. Procurement. CI_Trade_Party Main::CI_Trade_Party. Details
	Business Requirement 12/07/2009 Catalogue CAT0014 0..1 Procurement Party
0 .. 1	CICH_Supply Chain_Trade Agreement. Applicable. CI_Trade_Payment Terms Main::CI_Trade_Payment Terms. Details
	Business Requirement 12/07/2009 Catalogue CAT0017 0..1 Payment Instructions 12/07/2009 Catalogue CAT0018 0..1 Payment Terms
0 .. unbounded	CICH_Supply Chain_Trade Agreement. Contract_Referenced. CI_Referenced_Document Main::CI_Referenced_Document. Details
	Business Requirement 12/07/2009 Catalogue CAT0011 0..1 Contract Reference
0 .. 1	CICH_Supply Chain_Trade Agreement. Price List_Referenced. CI_Referenced_Document Main::CI_Referenced_Document. Details
	Business Requirement 12/07/2009 Catalogue CAT0010 0..1 Price List Reference
0 .. 1	CICH_Supply Chain_Trade Agreement. Catalogue_Referenced. CI_Referenced_Document Main::CI_Referenced_Document. Details
	Business Requirement 12/07/2009 Catalogue CAT0009 0..1 Catalogue reference (previous)
0 .. unbounded	CICH_Supply Chain_Trade Agreement. Purchase Conditions_Referenced. CI_Referenced_Document Main::CI_Referenced_Document. Details
	Business Requirement 12/07/2009 Catalogue CAT0024 0..* Purchase Conditions Reference
0 .. unbounded	CICH_Supply Chain_Trade Agreement. Sales Conditions_Referenced. CI_Referenced_Document Main::CI_Referenced_Document. Details
	Business Requirement 12/07/2009 Catalogue CAT0024 0..* Sales Conditions Reference
0 .. unbounded	CICH_Supply Chain_Trade Agreement. Target Market. CI_Trade_Country Main::CI_Trade_Country. Details
	Business Requirement 12/07/2009 Catalogue CAT0019 0..* Target market
0 .. unbounded	CICH_Supply Chain_Trade Agreement. Applicable. CI_Logistics_Location Main::CI_Logistics_Location. Details

Occurrence	Element/Attribute
	Business Requirement 12/07/2009 Catalogue CAT0021 0.* Delivery location
0 .. 1	CICH_Supply Chain_Trade Agreement. Shipping. CI_Specified_Period Main::CI_Specified_Period.Details
	Business Requirement 12/07/2009 Catalogue CAT0016 0..1 Delivery Date (period)
0 .. unbounded	CICH_Supply Chain_Trade Agreement. Catalogue Request_ Referenced. CI_Referenced_Document Main::CI_Referenced_Document.Details
	Business Requirement 13/07/2009 Catalogue CAT0003 0..1 Catalogue Request Reference
0 .. unbounded	CICH_Supply Chain_Trade Agreement. Catalogue Subscription_ Referenced. CI_Referenced_Document Main::CI_Referenced_Document.Details
	Business Requirement 13/07/2009 Catalogue CAT0004 0..1 Catalogue Subscription Reference
0 .. unbounded	CICH_Supply Chain_Trade Transaction. Included. CICH_Catalogue_Product Group Main::CICH_Catalogue_Product Group.Details
0 .. unbounded	CICH_Supply Chain_Trade Transaction. Included. CICL_Supply Chain_Trade Line Item Main::CICL_Supply Chain_Trade Line Item.Details

Occurrence	Element/Attribute
CICL_ Supply Chain_ Trade Line Item. Details	
0 .. 1	CICL_ Supply Chain_ Trade Line Item. Associated. CICL_ Document Line_ Document Main::CICL_ Document Line_ Document. Details
1 .. 1	CICL_ Document Line_ Document. Line. Identifier Business Requirement 03/06/2009 Catalogue CAI0100 1..1 Catalogue Item identification
1 .. 1	CICL_ Document Line_ Document. Line Status. Code Business Requirement 03/06/2009 Catalogue CAI0101 1..1 Catalogue Item action code
0 .. 1	CICL_ Document Line_ Document. Latest_ Revision. Date Time Business Requirement 12/07/2009 Catalogue CAI0106 0..1 Catalogue Item information change latest
0 .. unbounded	CICL_ Document Line_ Document. Included. CI_ Note Main::CI_ Note. Details
	Business Requirement 12/07/2009 Catalogue CAI0109 0..* Additional information (note)
0 .. 1	CICL_ Document Line_ Document. Effective. CI_ Specified_ Period Main::CI_ Specified_ Period. Details
	Business Requirement 12/07/2009 Catalogue CAI0105 0..1 Catalogue Item Validity Period
0 .. 1	CICL_ Supply Chain_ Trade Line Item. Specified. CICL_ Supply Chain_ Trade Agreement Main::CICL_ Supply Chain_ Trade Agreement. Details
	Business Requirement 12/07/2009 Catalogue CAI0122 0..1 Trade agreement
0 .. 1	CICL_ Supply Chain_ Trade Agreement. Product Availability. Code Business Requirement 12/07/2009 Catalogue CAI0102 0..1 Catalogue Item Availability code
0 .. 1	CICL_ Supply Chain_ Trade Agreement. Product Orderable. Indicator Business Requirement 12/07/2009 Catalogue TAG0235 0..1 Orderable indicator
0 .. 1	CICL_ Supply Chain_ Trade Agreement. Product Reorderable. Indicator Business Requirement 12/07/2009 Catalogue CAI0118 0..1 Reorderable indicator
0 .. 1	CICL_ Supply Chain_ Trade Agreement. Product Made To Order. Indicator Business Requirement 12/07/2009 Catalogue TAG0236 0..1 Made to order indicator
0 .. 1	CICL_ Supply Chain_ Trade Agreement. Delivery_ Order Fulfilment Lead Time. Business Requirement 12/07/2009 Catalogue TAG0237 0..1 Trade Item Delivery Lead Time
0 .. 1	CICL_ Supply Chain_ Trade Agreement. Pick-Up_ Order Fulfilment Lead Time. Business Requirement 12/07/2009 Catalogue TAG0238 0..1 Catalogue Item Pick Up Lead Time
0 .. 1	CICL_ Supply Chain_ Trade Agreement. Minimum_ Product Orderable. Quantity Business Requirement 12/07/2009 Catalogue TAG0240 0..1 Catalogue Item Minimum Order 16/08/2009 Catalogue DLT0741 0..1 Minimum Order quantity
0 .. 1	CICL_ Supply Chain_ Trade Agreement. Maximum_ Product Orderable. Quantit Business Requirement 12/07/2009 Catalogue TAG0242 0..1 Catalogue Item Maximum Order 16/08/2009 Catalogue DLT0742 0..1 Maximum Order quantity
0 .. 1	CICL_ Supply Chain_ Trade Agreement. Incremental_ Product Orderable. Quan Business Requirement 12/07/2009 Catalogue TAG0239 0..1 Catalogue Item Order Incremental
0 .. 1	CICL_ Supply Chain_ Trade Agreement. Order_ Product Unit Measure. Code Business Requirement 12/07/2009 Catalogue TAG0244 0..1 Ordering Unit Of Measure
0 .. 1	CICL_ Supply Chain_ Trade Agreement. Resale_ Product Unit Measure. Code

Occurrence	Element/Attribute
0 .. 1	<p>Business Requirement 12/07/2009 Catalogue TAG0245 0..1 Selling Unit Of Measure</p> <p>CICL_Supply Chain_Trade Agreement. Information Use Restriction. Indicator</p> <p>Business Requirement 12/07/2009 Catalogue TAG0227 0..1 Restricted information indicator</p>
0 .. 1	<p>CICL_Supply Chain_Trade Agreement. Seller. CI_Trade_Party Main::CI_Trade_Party. Details</p> <p>Business Requirement 12/07/2009 Catalogue TAG0221 0..1 Supplier</p>
0 .. 1	<p>CICL_Supply Chain_Trade Agreement. Procurement. CI_Trade_Party Main::CI_Trade_Party. Details</p> <p>Business Requirement 12/07/2009 Catalogue TAG0220 0..1 Procurement party</p>
0 .. 1	<p>CICL_Supply Chain_Trade Agreement. Catalogue_Information Provider. CI_Trade_Party Main::CI_Trade_Party. Details</p> <p>Business Requirement 12/07/2009 Catalogue CAI0103 0..1 Catalogue Item Provider party</p>
0 .. 1	<p>CICL_Supply Chain_Trade Agreement. Support Centre. CI_Trade_Party Main::CI_Trade_Party. Details</p> <p>Business Requirement 12/07/2009 Catalogue TAG0226 0..1 Customer support centre</p>
0 .. 1	<p>CICL_Supply Chain_Trade Agreement. Carrier. CI_Trade_Party Main::CI_Trade_Party. Details</p> <p>Business Requirement 14/08/2009 Catalogue TDY0301 0..1 Carrier</p>
0 .. 1	<p>CICL_Supply Chain_Trade Agreement. Applicable. CI_Trade_Delivery Terms Main::CI_Trade_Delivery Terms. Details</p> <p>Business Requirement 12/07/2009 Catalogue TAG0249 0..1 Delivery Terms</p>
0 .. unbounded	<p>CICL_Supply Chain_Trade Agreement. Gross Price_Product. CI_Trade_Price Main::CI_Trade_Price. Details</p> <p>Business Requirement 12/07/2009 Catalogue TAG0248 0..* Price information (gross)</p>
0 .. 1	<p>CI_Trade_Price.Type. Code</p> <p>Business Requirement 12/07/2009 Catalogue PRI0272 0..1 Price amount type code</p>
1 .. unbounded	<p>CI_Trade_Price.Charge.Amount</p> <p>Business Requirement 12/07/2009 Catalogue PRI0271 0..1 (1..1 in CI_)</p>
0 .. 1	<p>CI_Trade_Price.Basis.Quantity</p> <p>Business Requirement 12/07/2009 Catalogue PRI0274 0..1 Price basis quantity</p>
0 .. 1	<p>CI_Trade_Price.Order_Unit Conversion Factor. Numeric</p> <p>Business Requirement 13/07/2008 CSC PRI0009 0..1 Orderable unit factor rate</p>
0 .. unbounded	<p>CI_Trade_Price.Change Reason. Text</p> <p>Business Requirement 12/07/2009 Catalogue PRI0276 0..* Price Change Reason Text</p>
0 .. 1	<p>CI_Trade_Price.Minimum.Quantity</p> <p>Business Requirement 12/07/2009 Catalogue PRI0279 0..1 Bracket Price Quantity Range</p>
0 .. 1	<p>CI_Trade_Price.Maximum.Quantity</p> <p>Business Requirement 12/07/2009 Catalogue PRI0279 0..1 Bracket Price Quantity Range</p>
0 .. unbounded	<p>CI_Trade_Price.Applied. CI_Trade_Allowance Charge Main::CI_Trade_Allowance Charge. Details</p> <p>Business Requirement 12/07/2009 Catalogue PRI0275 0..* Allowance charge</p>

Occurrence	Element/Attribute
0 .. 1	CI_Trade_Price.Validity.CI_Specified_Period Main::CI_Specified_Period.Details Business Requirement 12/07/2009 Catalogue PRI0278 0..* (0..1 in CI_) Validity Period for Price
0 .. unbounded	CI_Trade_Price.Referenced.CI_Referenced_Document Main::CI_Referenced_Document.Details Business Requirement 13/07/2008 CSC PRI0008 0..1 Pricing Reference Document
0 .. unbounded	CI_Trade_Price.Delivery.CI_Trade_Location Main::CI_Trade_Location.Details Business Requirement 12/07/2009 Catalogue PRI0280 0..* Price Validity Location
0 .. unbounded	CI_Trade_Price.Trade_Comparison.Reference_Price Main::Reference_Price.Details Business Requirement 12/07/2009 Catalogue PRI0281 0..1 Price Comparison
0 .. unbounded	CI_CL_Supply_Chain_Trade_Agreement.Net_Price_Product.CI_Trade_Price Main::CI_Trade_Price.Details Business Requirement 12/07/2009 Catalogue TAG0248 0..* Price information (net)
0 .. 1	CI_Trade_Price.Type.Code Business Requirement 12/07/2009 Catalogue PRI0272 0..1 Price amount type code
1 .. unbounded	CI_Trade_Price.Charge.Amount Business Requirement 12/07/2009 Catalogue PRI0271 0..1 (1..1 in CI_) Catalogue Item Price amount
0 .. 1	CI_Trade_Price.Basis.Quantity Business Requirement 12/07/2009 Catalogue PRI0274 0..1 Price basis quantity
0 .. 1	CI_Trade_Price.Order_Unit_Conversion_Factor.Numeric Business Requirement 13/07/2008 CSC PRI0009 0..1 Orderable unit factor rate
0 .. unbounded	CI_Trade_Price.Change_Reason.Text Business Requirement 12/07/2009 Catalogue PRI0276 0..* Price Change Reason Text
0 .. 1	CI_Trade_Price.Minimum.Quantity Business Requirement 12/07/2009 Catalogue PRI0279 0..1 Bracket Price Quantity Range
0 .. 1	CI_Trade_Price.Maximum.Quantity Business Requirement 12/07/2009 Catalogue PRI0279 0..1 Bracket Price Quantity Range
0 .. unbounded	CI_Trade_Price.Applied.CI_Trade_Allowance_Charge Main::CI_Trade_Allowance_Charge.Details Business Requirement 12/07/2009 Catalogue PRI0275 0..* Allowance charge
0 .. 1	CI_Trade_Price.Validity.CI_Specified_Period Main::CI_Specified_Period.Details Business Requirement 12/07/2009 Catalogue PRI0278 0..* (0..1 in CI_) Validity Period for Price
0 .. unbounded	CI_Trade_Price.Referenced.CI_Referenced_Document Main::CI_Referenced_Document.Details Business Requirement 13/07/2008 CSC PRI0008 0..1 Pricing Reference Document
0 .. unbounded	CI_Trade_Price.Delivery.CI_Trade_Location Main::CI_Trade_Location.Details Business Requirement 12/07/2009 Catalogue PRI0280 0..* Price Validity Location

Occurrence	Element/Attribute
0 .. unbounded	CI_Trade_Price.Trade_Comparison.Reference_Price Main::Reference_Price.Details Business Requirement 12/07/2009 Catalogue PRI0281 0..1 Price Comparison
0 .. unbounded	CICL_Supply_Chain_Trade_Agreement.Target_Market.CI_Trade_Country Main::CI_Trade_Country.Details Business Requirement 12/07/2009 Catalogue CAI0120 0.* Target market
0 .. 1	CICL_Supply_Chain_Trade_Agreement.Ordering.CI_Specified_Period Main::CI_Specified_Period.Details Business Requirement 12/07/2009 Catalogue TAG0228 0..1 Product ordering period
0 .. 1	CICL_Supply_Chain_Trade_Agreement.Minimum_Order_Quantity_Ordering.CI_Specified_Period Main::CI_Specified_Period.Details Business Requirement 12/07/2009 Catalogue TAG0241 0..1 Catalogue Item Minimum Order Quantity
0 .. 1	CICL_Supply_Chain_Trade_Agreement.Maximum_Order_Quantity_Ordering.CI_Specified_Period Main::CI_Specified_Period.Details Business Requirement 12/07/2009 Catalogue TAG0243 0..1 Catalogue Item Maximum Order Quantity
0 .. 1	CICL_Supply_Chain_Trade_Agreement.Exclusivity.CI_Specified_Period Main::CI_Specified_Period.Details
0 .. unbounded	CI_Specified_Period.Duration.Measure
0 .. 1	CI_Specified_Period.Inclusive.Indicator
0 .. unbounded	CI_Specified_Period.Description.Text
0 .. 1	CI_Specified_Period.Start.Date.Time
0 .. 1	CI_Specified_Period.End.Date.Time
	Business Requirement 12/07/2009 Catalogue TAG0229 0..1 Product exclusivity end date time
0 .. 1	CI_Specified_Period.Complete.Date.Time
0 .. 1	CI_Specified_Period.Season.Code
0 .. 1	CI_Specified_Period.Identification.Identifier
0 .. unbounded	CI_Specified_Period.Name.Text
0 .. 1	CI_Specified_Period.Sequence.Numeric
0 .. 1	CI_Specified_Period.Start.Date.Flexibility.Code
0 .. 1	CI_Specified_Period.Continuous.Indicator
0 .. 1	CICL_Supply_Chain_Trade_Agreement.Resale.CI_Specified_Period Main::CI_Specified_Period.Details
0 .. unbounded	CI_Specified_Period.Duration.Measure
0 .. 1	CI_Specified_Period.Inclusive.Indicator
0 .. unbounded	CI_Specified_Period.Description.Text
0 .. 1	CI_Specified_Period.Start.Date.Time
	Business Requirement 12/07/2009 Catalogue TAG0230 0..1 Availability to consumer start date
0 .. 1	CI_Specified_Period.End.Date.Time
0 .. 1	CI_Specified_Period.Complete.Date.Time
0 .. 1	CI_Specified_Period.Season.Code
0 .. 1	CI_Specified_Period.Identification.Identifier
0 .. unbounded	CI_Specified_Period.Name.Text
0 .. 1	CI_Specified_Period.Sequence.Numeric
0 .. 1	CI_Specified_Period.Start.Date.Flexibility.Code
0 .. 1	CI_Specified_Period.Continuous.Indicator
0 .. 1	CICL_Supply_Chain_Trade_Agreement.Guaranteed_Product_Life_Span.CI_Specified_Period Main::CI_Specified_Period.Details

Occurrence	Element/Attribute
	Business Requirement
	12/07/2009 Catalogue TAG0243 0..1 Catalogue Item Maximum Order Quantity
0 .. unbounded	CI_ Specified_ Period. Duration. Measure
	Business Requirement
	23/10/2009 Catalogue TAG0232 0..1 Minimum product lifespan from time of
0 .. 1	CI_ Specified_ Period. Inclusive. Indicator
0 .. unbounded	CI_ Specified_ Period. Description. Text
0 .. 1	CI_ Specified_ Period. Start. Date Time
0 .. 1	CI_ Specified_ Period. End. Date Time
0 .. 1	CI_ Specified_ Period. Complete. Date Time
0 .. 1	CI_ Specified_ Period. Season. Code
0 .. 1	CI_ Specified_ Period. Identification. Identifier
0 .. unbounded	CI_ Specified_ Period. Name. Text
0 .. 1	CI_ Specified_ Period. Sequence. Numeric
0 .. 1	CI_ Specified_ Period. Start Date Flexibility. Code
0 .. 1	CI_ Specified_ Period. Continuous. Indicator
0 .. 1	CICL_ Supply Chain_ Trade Agreement. Immediate_ Previous Price List_ Referenced. CI_ Referenced_ Document
	Main::CI_ Referenced_ Document. Details
0 .. 1	CI_ Referenced_ Document. Issuer Assigned_ Identification. Identifier
	Business Requirement
	12/07/2009 Catalogue PLR0285 0..1 Immediate previous price list
0 .. 1	CI_ Referenced_ Document. URI_ Identification. Identifier
	Business Requirement
	12/07/2008 CSC REF0006 0..1 Reference URI
0 .. 1	CI_ Referenced_ Document. Issue. Date Time
	Business Requirement
	12/07/2008 CSC REF0003 0..1 Reference date
0 .. 1	CI_ Referenced_ Document. Status. Code
	Business Requirement
	12/07/2008 CSC REF0004 0..1 Reference status
0 .. 1	CI_ Referenced_ Document. Copy. Indicator
	Business Requirement
	12/07/2008 CSC REF0008 0..1 Copy indicator
0 .. 1	CI_ Referenced_ Document. Line. Identifier
	Business Requirement
	12/07/2008 CSC REF0009 0..1 Reference line number
0 .. 1	CI_ Referenced_ Document. Reference_ Type. Code
	Business Requirement
	08/09/2008 CSC REF0012 0..1 Document type
0 .. 1	CI_ Referenced_ Document. Global_ Identification. Identifier
	Business Requirement
	08/09/2008 CSC REF0007 0..1 Reference GUID
0 .. 1	CI_ Referenced_ Document. Revision_ Identification. Identifier
	Business Requirement
	08/09/2008 CSC REF0005 0..1 Reference index ID
0 .. unbounded	CI_ Referenced_ Document. Name. Text
	Business Requirement
	12/07/2008 CSC REF0002 0..1 Reference Document Name
0 .. unbounded	CI_ Referenced_ Document. Information. Text
0 .. unbounded	CI_ Referenced_ Document. Previous Revision_ Identification. Identifier
0 .. unbounded	CI_ Referenced_ Document. Section Name. Text
0 .. unbounded	CICL_ Supply Chain_ Trade Agreement. Contract_ Referenced. CI_ Referenced_ Document
	Main::CI_ Referenced_ Document. Details
0 .. 1	CI_ Referenced_ Document. Issuer Assigned_ Identification. Identifier
	Business Requirement
	12/07/2009 Catalogue TAG0223 0..1 Contract reference

Occurrence	Element/Attribute
0 .. 1	<ul style="list-style-type: none"> — <i>CI_ Referenced_ Document. URI_ Identification. Identifier</i> Business Requirement 12/07/2008 CSC REF0006 0..1 Reference URI
0 .. 1	<ul style="list-style-type: none"> — <i>CI_ Referenced_ Document. Issue. Date Time</i> Business Requirement 12/07/2008 CSC REF0003 0..1 Reference date
0 .. 1	<ul style="list-style-type: none"> — <i>CI_ Referenced_ Document. Status. Code</i> Business Requirement 12/07/2008 CSC REF0004 0..1 Reference status
0 .. 1	<ul style="list-style-type: none"> — <i>CI_ Referenced_ Document. Copy. Indicator</i> Business Requirement 12/07/2008 CSC REF0008 0..1 Copy indicator
0 .. 1	<ul style="list-style-type: none"> — <i>CI_ Referenced_ Document. Line. Identifier</i> Business Requirement 12/07/2008 CSC REF0009 0..1 Reference line number
0 .. 1	<ul style="list-style-type: none"> — <i>CI_ Referenced_ Document. Reference_ Type. Code</i> Business Requirement 08/09/2008 CSC REF0012 0..1 Document type
0 .. 1	<ul style="list-style-type: none"> — <i>CI_ Referenced_ Document. Global_ Identification. Identifier</i> Business Requirement 08/09/2008 CSC REF0007 0..1 Reference GUID
0 .. 1	<ul style="list-style-type: none"> — <i>CI_ Referenced_ Document. Revision_ Identification. Identifier</i> Business Requirement 08/09/2008 CSC REF0005 0..1 Reference index ID
0 .. unbounded	<ul style="list-style-type: none"> — <i>CI_ Referenced_ Document. Name. Text</i> Business Requirement 12/07/2008 CSC REF0002 0..1 Reference Document Name
0 .. unbounded	— <i>CI_ Referenced_ Document. Information. Text</i>
0 .. unbounded	— <i>CI_ Referenced_ Document. Previous Revision_ Identification. Identifier</i>
0 .. unbounded	<ul style="list-style-type: none"> — <i>CI_ Referenced_ Document. Section Name. Text</i> Business Requirement 12/07/2009 Catalogue TAG0224 0..1 Contract sub-division
0 .. 1	CICL_ Supply Chain_ Trade Agreement. Price List_ Referenced. CI_ Referenced_ Document Main::CI_ Referenced_ Document. Details Business Requirement
0 .. 1	<ul style="list-style-type: none"> 12/07/2009 Catalogue PRI0270 0..1 Price list reference
0 .. 1	<ul style="list-style-type: none"> — <i>CI_ Referenced_ Document. Issuer Assigned_ Identification. Identifier</i> Business Requirement 12/07/2009 Catalogue PLRI0283 0..1 Price list reference
0 .. 1	<ul style="list-style-type: none"> — <i>CI_ Referenced_ Document. URI_ Identification. Identifier</i> Business Requirement 12/07/2008 CSC REF0006 0..1 Reference URI
0 .. 1	<ul style="list-style-type: none"> — <i>CI_ Referenced_ Document. Issue. Date Time</i> Business Requirement 12/07/2008 CSC REF0003 0..1 Reference date
0 .. 1	<ul style="list-style-type: none"> — <i>CI_ Referenced_ Document. Status. Code</i> Business Requirement 12/07/2008 CSC REF0004 0..1 Reference status
0 .. 1	<ul style="list-style-type: none"> — <i>CI_ Referenced_ Document. Copy. Indicator</i> Business Requirement 12/07/2008 CSC REF0008 0..1 Copy indicator
0 .. 1	<ul style="list-style-type: none"> — <i>CI_ Referenced_ Document. Line. Identifier</i> Business Requirement 12/07/2008 CSC REF0009 0..1 Reference line number
0 .. 1	<ul style="list-style-type: none"> — <i>CI_ Referenced_ Document. Reference_ Type. Code</i> Business Requirement 08/09/2008 CSC REF0012 0..1 Document type
0 .. 1	<ul style="list-style-type: none"> — <i>CI_ Referenced_ Document. Global_ Identification. Identifier</i> Business Requirement 08/09/2008 CSC REF0007 0..1 Reference GUID

Occurrence	Element/Attribute
0 .. 1	<p>— <i>CI_Referenced_Document.Revision_Identification.Identifier</i> Business Requirement 08/09/2008 CSC REF0005 0..1 Reference index ID</p>
0 .. unbounded	<p>— <i>CI_Referenced_Document.Name.Text</i> Business Requirement 12/07/2008 CSC REF0002 0..1 Reference Document Name</p>
0 .. unbounded	— <i>CI_Referenced_Document.Information.Text</i>
0 .. unbounded	— <i>CI_Referenced_Document.Previous_Revision_Identification.Identifier</i>
0 .. unbounded	— <i>CI_Referenced_Document.Section_Name.Text</i>
0 .. 1	<p>— CI_Referenced_Document.Issuer.CI_Trade_Party Main::CI_Trade_Party.Details Business Requirement 12/07/2008 CSC REF0011 0..1 Referenced document issuer party</p>
0 .. unbounded	<p>— CI_Referenced_Document.Attached.Specified_Binary_File Main::Specified_Binary_File.Details Business Requirement 15/05/2009 CSC REF0014 0.* Attached Binary File</p>
0 .. 1	<p>— CI_Referenced_Document.Effective.CI_Specified_Period Main::CI_Specified_Period.Details Business Requirement 12/07/2009 Catalogue PLR0284 0..1 Validity period</p>
0 .. unbounded	<p>— CICL_Supply_Chain_Trade_Agreement.Sales_Conditions_Referenced.CI_Referenced_Document Main::CI_Referenced_Document.Details Business Requirement 12/07/2009 Catalogue TAG0222 0.* Trading terms</p>
0 .. 1	<p>— CICL_Supply_Chain_Trade_Line_Item.Specified.CICL_Supply_Chain_Trade_Delivery Main::CICL_Supply_Chain_Trade_Delivery.Details Business Requirement 12/07/2009 Catalogue CAI0123 0..1 Trade Delivery</p>
0 .. 1	<p>— CICL_Supply_Chain_Trade_Delivery.Handling.CI_Handling_Instructions Main::CI_Handling_Instructions.Details Business Requirement 13/07/2009 Catalogue TDY0300 0..1 Handling Instructions</p>
0 .. 1	<p>— CICL_Supply_Chain_Trade_Line_Item.Specified.CICL_Supply_Chain_Trade_Settlement Main::CICL_Supply_Chain_Trade_Settlement.Details</p>
0 .. unbounded	<p>— CICL_Supply_Chain_Trade_Settlement.Applicable.CI_Trade_Tax Main::CI_Trade_Tax.Details Business Requirement 12/07/2009 Catalogue CAI0121 0.* Tax Information</p>
1 .. 1	<p>— CICL_Supply_Chain_Trade_Line_Item.Specified.Catalogue_Trade_Product Main::Catalogue_Trade_Product.Details Business Requirement 12/07/2009 Catalogue CAI0124 1..1 Trade product</p>
0 .. unbounded	<p>— <i>Catalogue_Trade_Product.Identification.Identifier</i> Business Requirement 13/07/2009 Catalogue PRO0312 0..1 Product identification</p>
0 .. unbounded	<p>— <i>Catalogue_Trade_Product.Global_Identification.Identifier</i> Business Requirement 13/07/2009 Catalogue PRO0312 0..1 Product identification</p>
0 .. 1	<p>— <i>Catalogue_Trade_Product.Seller_Assigned_Identification.Identifier</i> Business Requirement 13/07/2009 Catalogue PRO0312 0..1 Product identification</p>
0 .. 1	<p>— <i>Catalogue_Trade_Product.Buyer_Assigned_Identification.Identifier</i> Business Requirement 13/07/2009 Catalogue PRO0312 0..1 Product identification</p>
0 .. unbounded	<p>— <i>Catalogue_Trade_Product.Manufacturer_Assigned_Identification.Identifier</i></p>

Occurrence	Element/Attribute
	Business Requirement
0 .. unbounded	13/07/2009 Catalogue PRO0312 0..1 Product identification — <i>Catalogue_Trade_Product. Industry Assigned_ Identification. Identifier</i>
	Business Requirement
0 .. unbounded	13/07/2009 Catalogue PRO0312 0..1 Product identification — <i>Catalogue_Trade_Product. Tracking System. Identifier</i>
	Business Requirement
0 .. unbounded	12/07/2009 Catalogue CAI0119 0..* Tracking system identifier — <i>Catalogue_Trade_Product. Name. Text</i>
	Business Requirement
0 .. unbounded	13/07/2009 Catalogue PRO0326 0..* Product Name — <i>Catalogue_Trade_Product. Gross Weight. Measure</i>
	Business Requirement
0 .. 1	13/07/2009 Catalogue DIM0441 0..1 Product Gross — <i>Catalogue_Trade_Product. Drained_ Net Weight. Measure</i>
	Business Requirement
0 .. 1	13/07/2009 Catalogue PRO0337 0..1 Product Drained Weight — <i>Catalogue_Trade_Product. From Opening_ Life Span. Measure</i>
0 .. 1	— <i>Catalogue_Trade_Product. From Delivery_ Life Span. Measure</i>
0 .. 1	— <i>Catalogue_Trade_Product. Area Density. Measure</i>
	Business Requirement
0 .. 1	13/08/2009 Catalogue DIM0440 0..1 Product Material Area Weight — <i>Catalogue_Trade_Product. From Production_ Life Span. Measure</i>
0 .. unbounded	— <i>Catalogue_Trade_Product. Unit_ Type. Code</i>
	Business Requirement
0 .. 1	13/07/2009 Catalogue PRO0319 0..1 Consumer Unit Indicator 13/07/2009 Catalogue PRO0320 0..1 Role type code — <i>Catalogue_Trade_Product. Production Discontinued. Date Time</i>
	Business Requirement
0 .. 1	13/07/2009 Catalogue PRO0324 0..1 Product Discontinued date — <i>Catalogue_Trade_Product. Cancellation_ Announced Launch. Date Time</i>
	Business Requirement
0 .. unbounded	13/07/2009 Catalogue PRO0321 0..1 Product Launch Cancellation date — <i>Catalogue_Trade_Product. Batch_ Identification. Identifier</i>
	Business Requirement
0 .. 1	13/07/2009 Catalogue TDY0302 0..* Production Batch identification — <i>Catalogue_Trade_Product. Latest_ Product Data Change. Date Time</i>
	Business Requirement
0 .. unbounded	13/07/2009 Catalogue PRO0325 0..1 Product change latest date — <i>Catalogue_Trade_Product. Function_ Description. Text</i>
	Business Requirement
0 .. unbounded	13/07/2009 Catalogue PRO0327 0..* Product Functional Description Text — <i>Catalogue_Trade_Product. Concise_ Description. Text</i>
	Business Requirement
0 .. unbounded	13/07/2009 Catalogue PRO0328 0..* Product Description short — <i>Catalogue_Trade_Product. Variant_ Description. Text</i>
	Business Requirement
0 .. unbounded	13/07/2009 Catalogue PRO0331 0..* Variant description text — <i>Catalogue_Trade_Product. Additional_ Description. Text</i>
	Business Requirement
0 .. unbounded	13/07/2009 Catalogue PRO0330 0..* Additional product description text — <i>Catalogue_Trade_Product. Physical Form_ Description. Text</i>
	Business Requirement
0 .. 1	13/07/2009 Catalogue PRO0334 0..* Descriptive Form Text — <i>Catalogue_Trade_Product. Brand_ Name. Text</i>
	Business Requirement
0 .. 1	13/07/2009 Catalogue PRO0332 0..1 Product Brand Name — <i>Catalogue_Trade_Product. Sub-Brand_ Name. Text</i>
	Business Requirement
0 .. 1	13/07/2009 Catalogue PRO0333 0..1 Sub Brand Name — <i>Catalogue_Trade_Product. Common_ Name. Text</i>

Occurrence	Element/Attribute
0 .. 1	<i>Catalogue_Trade_Product.Scientific_Name.Text</i>
0 .. 1	<i>Catalogue_Trade_Product.Content_Variable_Measure.Indicator</i> Business Requirement
	13/07/2009 Catalogue PRO0338 0..1 Trade Item Variable Measure
0 .. 1	<i>Catalogue_Trade_Product.Configurable.Indicator</i> Business Requirement
	13/07/2009 Catalogue PRO0345 0..1 Customer Configurable
0 .. 1	<i>Catalogue_Trade_Product.Marked_Serial_Number.Indicator</i> Business Requirement
	13/07/2009 Catalogue PRO0347 0..1 Product marked with Serial number Indicator
0 .. 1	<i>Catalogue_Trade_Product.Pre-Packaged.Indicator</i> Business Requirement
	13/07/2009 Catalogue PRO0344 0..1 Product Prepack Type
0 .. 1	<i>Catalogue_Trade_Product.Colour.Code</i> Business Requirement
	13/07/2009 Catalogue PRO0342 0..1 Product colour code
0 .. unbounded	<i>Catalogue_Trade_Product.Colour_Description.Text</i> Business Requirement
	13/07/2009 Catalogue PRO0343 0..* Product colour description
0 .. 1	<i>Catalogue_Trade_Product.Content_Unit.Quantity</i> Business Requirement
	13/07/2009 Catalogue PRO0335 0..1 Product Content Quantity
0 .. 1	<i>Catalogue_Trade_Product.Inner_Pack_Content_Unit.Quantity</i> Business Requirement
	14/08/2009 Catalogue HLL0520 0..1 Number (quantity) of different products
0 .. 1	<i>Catalogue_Trade_Product.Inner_Pack.Quantity</i> Business Requirement
	14/08/2009 Catalogue HLL0521 0..1 Product Total Quantity
0 .. 1	<i>Catalogue_Trade_Product.Included_Product_Content_Unit.Quantity</i> Business Requirement
	13/07/2009 Catalogue PRO0361 0..1 Quantity Of Next Level Product Within
0 .. 1	<i>Catalogue_Trade_Product.Included_Product_Type.Quantity</i> Business Requirement
	13/08/2009 Catalogue PRO0336 0..1 Quantity Of Product Contained In Inner
0 .. unbounded	Catalogue_Trade_Product.Manufacturer.CI_Trade_Party Main::CI_Trade_Party.Details Business Requirement
	13/07/2009 Catalogue PRO0322 0..1 Manufacturer Party
0 .. 1	Catalogue_Trade_Product.Legal_Rights_Owner.CI_Trade_Party Main::CI_Trade_Party.Details Business Requirement
	13/07/2009 Catalogue PRO0323 0..1 Product rights owner party
0 .. 1	Catalogue_Trade_Product.Brand_Owner.CI_Trade_Party Main::CI_Trade_Party.Details Business Requirement
	13/07/2009 Catalogue MAR0403 0..1 Brand owner party
0 .. unbounded	Catalogue_Trade_Product.Applicable.CI_Product_Characteristic Main::CI_Product_Characteristic.Details Business Requirement
	13/07/2009 Catalogue PRO0357 0..n Property characteristic
0 .. unbounded	Catalogue_Trade_Product.Applicable.CI_Material_Goods_Characteristic Main::CI_Material_Goods_Characteristic.Details Business Requirement
	13/07/2009 Catalogue PRO0359 0..n Product Material
0 .. unbounded	<i>CI_Material_Goods_Characteristic.Description.Text</i> Business Requirement
	13/07/2008 CSC MAT0004 0..* Material description

Occurrence	Element/Attribute
0 .. 1	<ul style="list-style-type: none"> — <i>CI_Material_Goods Characteristic. Type. Code</i>
	<ul style="list-style-type: none"> Business Requirement 15/08/2009 Catalogue PML0630 1..1 Product Material code
0 .. 1	<ul style="list-style-type: none"> — <i>CI_Material_Goods Characteristic. Proportional_Constituent. Percent</i>
	<ul style="list-style-type: none"> Business Requirement 13/07/2008 CSC MAT0002 0..1 Material percentage
0 .. 1	<ul style="list-style-type: none"> — <i>CI_Material_Goods Characteristic. Absolute Presence_Weight. Measure</i>
	<ul style="list-style-type: none"> Business Requirement 13/07/2008 CSC MAT0003 0..* Material weight quantity
0 .. 1	<ul style="list-style-type: none"> — <i>CI_Material_Goods Characteristic. Absolute Presence_Volume. Measure</i>
	<ul style="list-style-type: none"> Business Requirement 13/07/2008 CSC MAT0003 0..* Material volume quantity
0 .. unbounded	<ul style="list-style-type: none"> — Catalogue Trade Product. Designated. CI Product Classification
	<ul style="list-style-type: none"> Main::CI_Product_Classification. Details Business Requirement 13/07/2009 Catalogue PRO0358 0..n Product classification
0 .. 1	<ul style="list-style-type: none"> — <i>CI_Product_Classification. System. Identifier</i>
0 .. unbounded	<ul style="list-style-type: none"> — <i>CI_Product_Classification. System Name. Text</i>
0 .. 1	<ul style="list-style-type: none"> — <i>CI_Product_Classification. Class. Code</i>
	<ul style="list-style-type: none"> Business Requirement 16/08/2009 Catalogue PCL0678 0..1 Class Code
0 .. unbounded	<ul style="list-style-type: none"> — <i>CI_Product_Classification. Class Name. Text</i>
0 .. 1	<ul style="list-style-type: none"> — <i>CI_Product_Classification. Sub_Class. Code</i>
0 .. unbounded	<ul style="list-style-type: none"> — Catalogue Trade Product. Individual. CI Trade Product Instance
	<ul style="list-style-type: none"> Main::CI_Trade_Product Instance. Details Business Requirement 13/07/2009 Catalogue PRO0350 0..* Product Instance
0 .. 1	<ul style="list-style-type: none"> — <i>CI_Trade_Product Instance. Global Serial_ Identification. Identifier</i>
	<ul style="list-style-type: none"> Business Requirement 16/08/2009 Catalogue PRU0650 0..1 Product Unit Individual Identification
0 .. 1	<ul style="list-style-type: none"> — <i>CI_Trade_Product Instance. Batch_ Identification. Identifier</i>
	<ul style="list-style-type: none"> Business Requirement 16/08/2009 Catalogue PRU0655 0..1 Production Batch Identification
0 .. 1	<ul style="list-style-type: none"> — <i>CI_Trade_Product Instance. Kanban_ Identification. Identifier</i>
	<ul style="list-style-type: none"> Business Requirement 13/07/2008 CSC PIN0005 0..1 Kanban number
0 .. 1	<ul style="list-style-type: none"> — <i>CI_Trade_Product Instance. Supplier Assigned Serial_ Identification. Identifier</i>
	<ul style="list-style-type: none"> Business Requirement 13/07/2008 CSC PIN0001 0..1 Supplier item identification
0 .. 1	<ul style="list-style-type: none"> — <i>CI_Trade_Product Instance. Best Before. Date Time</i>
	<ul style="list-style-type: none"> Business Requirement 13/07/2008 CSC PIN0007 0..1 Best before date time
0 .. 1	<ul style="list-style-type: none"> — <i>CI_Trade_Product Instance. Expiry. Date Time</i>
	<ul style="list-style-type: none"> Business Requirement 13/07/2008 CSC PIN0008 0..1 Expiration date time
0 .. 1	<ul style="list-style-type: none"> — <i>CI_Trade_Product Instance. Sell By. Date Time</i>
	<ul style="list-style-type: none"> Business Requirement 13/07/2008 CSC PIN0010 0..1 Sell by date
0 .. unbounded	<ul style="list-style-type: none"> — <i>CI_Trade_Product Instance. Serial_ Identification. Identifier</i>
	<ul style="list-style-type: none"> Business Requirement 16/08/2009 Catalogue PRU0654 0..1 Product Instance Serial Number
0 .. unbounded	<ul style="list-style-type: none"> — <i>CI_Trade_Product Instance. Registration_ Identification. Identifier</i>
	<ul style="list-style-type: none"> Business Requirement 16/08/2009 Catalogue PRU0652 0..1 Registration Identification
0 .. unbounded	<ul style="list-style-type: none"> — CI Trade Product Instance. Product. CI Product Characteristic
	<ul style="list-style-type: none"> Main::CI_Product_Characteristic. Details Business Requirement 13/07/2008 CSC PIN0011 0..* Characteristic
0 .. 1	<ul style="list-style-type: none"> — CI Trade Product Instance. Production. CI Supply Chain Event
	<ul style="list-style-type: none"> Main::CI_Supply Chain_Event. Details
0 .. 1	<ul style="list-style-type: none"> — <i>CI_Supply Chain_Event. Identification. Identifier</i>

Occurrence	Element/Attribute
0 .. 1	<ul style="list-style-type: none"> — <i>CI_Supply Chain_Event.Occurrence.Date Time</i> Business Requirement 16/08/2009 Catalogue PRU0651 0..1 Manufacture Date Time
0 .. 1	<ul style="list-style-type: none"> — <i>CI_Supply Chain_Event.Type.Code</i>
0 .. unbounded	<ul style="list-style-type: none"> — <i>CI_Supply Chain_Event.Description.Text</i>
0 .. unbounded	<ul style="list-style-type: none"> — <i>CI_Supply Chain_Event.Description.Binary Object</i>
0 .. 1	<ul style="list-style-type: none"> — <i>CI_Supply Chain_Event.Unit.Quantity</i>
0 .. 1	<ul style="list-style-type: none"> — <i>CI_Supply Chain_Event.Latest_Occurrence.Date Time</i>
0 .. 1	<ul style="list-style-type: none"> — <i>CI_Supply Chain_Event.Earliest_Occurrence.Date Time</i>
0 .. 1	<ul style="list-style-type: none"> — CI_Trade_Product Instance.Packaging.CI_Supply Chain_Event Main::CI_Supply Chain_Event.Details
0 .. unbounded	<ul style="list-style-type: none"> — CI_Trade_Product Instance.Applicable.CI_Material_Goods Characteristic Main::CI_Material_Goods Characteristic.Details
0 .. unbounded	<ul style="list-style-type: none"> — Catalogue_Trade_Product.Included.CI_Referenced_Product Main::CI_Referenced_Product.Details Business Requirement 13/07/2009 Catalogue PRO0354 0..1 Hierarchy information 14/08/2009 Catalogue HII0522 not used for Next lower product level information. single-level product, 1:1 for multipacks or 1:n for mixed-pack products
0 .. unbounded	<ul style="list-style-type: none"> — <i>CI_Referenced_Product.Identification.Identifier</i> Business Requirement 14/08/2009 Catalogue NLL0523 at least one ID must be provided (0..1 in CCL) Product Identification of a product contained in a product
0 .. unbounded	<ul style="list-style-type: none"> — <i>CI_Referenced_Product.Global_Identification.Identifier</i> Business Requirement 14/08/2009 Catalogue NLL0523 at least one ID must be provided (0..1 in CCL) Product Identification of a product contained in a product
0 .. 1	<ul style="list-style-type: none"> — <i>CI_Referenced_Product.Seller Assigned_Identification.Identifier</i> Business Requirement 14/08/2009 Catalogue NLL0523 at least one ID must be provided (0..1 in CCL) Product Identification of a product contained in a product
0 .. 1	<ul style="list-style-type: none"> — <i>CI_Referenced_Product.Buyer Assigned_Identification.Identifier</i> Business Requirement 14/08/2009 Catalogue NLL0523 at least one ID must be provided (0..1 in CCL) Product Identification of a product contained in a product
0 .. 1	<ul style="list-style-type: none"> — <i>CI_Referenced_Product.Manufacturer Assigned_Identification.Identifier</i> Business Requirement 14/08/2009 Catalogue NLL0523 at least one ID must be provided (0..1 in CCL) Product Identification of a product contained in a product
0 .. 1	<ul style="list-style-type: none"> — <i>CI_Referenced_Product.Industry Assigned_Identification.Identifier</i> Business Requirement 14/08/2009 Catalogue NLL0523 at least one ID must be provided (0..1 in CCL) Product Identification of a product contained in a product
0 .. unbounded	<ul style="list-style-type: none"> — <i>CI_Referenced_Product.Description.Text</i>
0 .. unbounded	<ul style="list-style-type: none"> — <i>CI_Referenced_Product.Relationship_Type.Code</i>

Occurrence	Element/Attribute
0 .. unbounded	<ul style="list-style-type: none"> — <i>CL_Referenced_Product_Unit_Quantity</i> Business Requirement 14/08/2009 Catalogue NLL0524 1..1 Quantity Of Products contained in a product
0 .. unbounded	<ul style="list-style-type: none"> — Catalogue_Trade_Product_Origin_CI_Trade_Country Main::CI_Trade_Country_Details
0 .. 1	<ul style="list-style-type: none"> — <i>CI_Trade_Country_Identification_Identifier</i> Business Requirement 13/07/2009 Catalogue PRO0339 0..1 Country of origin Code
0 .. unbounded	<ul style="list-style-type: none"> — <i>CI_Trade_Country_Name_Text</i>
0 .. unbounded	<ul style="list-style-type: none"> — CI_Trade_Country_Subordinate_CI_Trade_Country Sub-Division Main::CI_Trade_Country Sub-Division_Details
0 .. 1	<ul style="list-style-type: none"> — <i>CI_Trade_Country Sub-Division_Identification_Identifier</i> Business Requirement 13/07/2009 Catalogue PRO0340 0..1 Sub-division Country of origin Code
0 .. unbounded	<ul style="list-style-type: none"> — <i>CI_Trade_Country Sub-Division_Name_Text</i>
0 .. unbounded	<ul style="list-style-type: none"> — Catalogue_Trade_Product_Supplied From_CI_Trade_Country Main::CI_Trade_Country_Details
0 .. unbounded	<ul style="list-style-type: none"> — Catalogue_Trade_Product_Final_Assembly_CI_Trade_Country Main::CI_Trade_Country_Details
0 .. 1	<ul style="list-style-type: none"> — <i>CI_Trade_Country_Identification_Identifier</i> Business Requirement 13/07/2009 Catalogue PRO0341 0..1 Country of assembly code
0 .. unbounded	<ul style="list-style-type: none"> — <i>CI_Trade_Country_Name_Text</i>
0 .. unbounded	<ul style="list-style-type: none"> — Catalogue_Trade_Product_Linear_CI_Spatial_Dimension Main::CI_Spatial_Dimension_Details
0 .. 1	<ul style="list-style-type: none"> — <i>CL_Spatial_Dimension_Value_Measure</i>
0 .. 1	<ul style="list-style-type: none"> — <i>CL_Spatial_Dimension_Type_Code</i>
0 .. unbounded	<ul style="list-style-type: none"> — <i>CL_Spatial_Dimension_Description_Text</i>
0 .. 1	<ul style="list-style-type: none"> — <i>CL_Spatial_Dimension_Width_Measure</i> Business Requirement 13/07/2009 Catalogue DIM0444 0..1 Product Width
0 .. 1	<ul style="list-style-type: none"> — <i>CL_Spatial_Dimension_Length_Measure</i> Business Requirement 13/07/2009 Catalogue DIM0443 0..1 Product depth
0 .. 1	<ul style="list-style-type: none"> — <i>CL_Spatial_Dimension_Height_Measure</i> Business Requirement 13/07/2009 Catalogue DIM0442 0..1 Product Height
0 .. 1	<ul style="list-style-type: none"> — <i>CL_Spatial_Dimension_Identification_Identifier</i>
0 .. 1	<ul style="list-style-type: none"> — <i>CL_Spatial_Dimension_Diameter_Measure</i> Business Requirement 13/07/2009 Catalogue DIM0445 0..1 Product Diameter
0 .. unbounded	<ul style="list-style-type: none"> — Catalogue_Trade_Product_Minimum_Linear_CI_Spatial_Dimension Main::CI_Spatial_Dimension_Details
0 .. unbounded	<ul style="list-style-type: none"> — Catalogue_Trade_Product_Maximum_Linear_CI_Spatial_Dimension Main::CI_Spatial_Dimension_Details
0 .. unbounded	<ul style="list-style-type: none"> — Catalogue_Trade_Product_Applicable_Trade Product_Supply Chain_Packaging Main::Trade Product_Supply Chain_Packaging_Details
0 .. 1	<ul style="list-style-type: none"> — <i>Trade Product_Supply Chain_Packaging_Customer Facing_Total Unit_Quantit</i> Business Requirement 13/07/2009 Catalogue PRO0352 0..1 Trade Packaging information
0 .. unbounded	<ul style="list-style-type: none"> — <i>Trade Product_Supply Chain_Packaging_Total Unit_Quantity</i> Business Requirement 15/08/2009 Catalogue PGI0606 0..1 Number of items per width
0 .. 1	<ul style="list-style-type: none"> — <i>Trade Product_Supply Chain_Packaging_Layer_Total Unit_Quantity</i> Business Requirement 15/08/2009 Catalogue LUI0591 0..1 Quantity of product per logistic unit

Occurrence	Element/Attribute
	Business Requirement 15/08/2009 Catalogue PGI0607 0..1 Quantity of products contained in a complete layer
0 .. 1	Trade Product_Supply Chain_Packaging_Returnable_Indicator
0 .. 1	Trade Product_Supply Chain_Packaging_Linear_CI_Spatial_Dimension Main::CI_Spatial_Dimension_Details
	Business Requirement 13/07/2009 Catalogue PRO0355 0..1 Physical dimensions
0 .. unbounded	Trade Product_Supply Chain_Packaging_Specified_CI_Packaging_Marking Main::CI_Packaging_Marking_Details
	Business Requirement 15/08/2009 Catalogue PGI0609 0..n Marks and labels
0 .. unbounded	Catalogue_Trade_Product_Marketing Campaign_Reference_CI_Referenced_Document Main::CI_Referenced_Document_Details
	Business Requirement 03/06/2009 Catalogue MAR0400 0..1 Campaign
0 .. 1	CI_Referenced_Document_Issuer_Assigned_Identifier_Identifier
	Business Requirement 12/07/2008 CSC REF0001 1..1 Reference number
0 .. 1	CI_Referenced_Document_URI_Identifier_Identifier
	Business Requirement 12/07/2008 CSC REF0006 0..1 Reference URI
0 .. 1	CI_Referenced_Document_Issue_Date_Time
	Business Requirement 12/07/2008 CSC REF0003 0..1 Reference date
0 .. 1	CI_Referenced_Document_Status_Code
	Business Requirement 12/07/2008 CSC REF0004 0..1 Reference status
0 .. 1	CI_Referenced_Document_Copy_Indicator
	Business Requirement 12/07/2008 CSC REF0008 0..1 Copy indicator
0 .. 1	CI_Referenced_Document_Line_Identifier
	Business Requirement 12/07/2008 CSC REF0009 0..1 Reference line number
0 .. 1	CI_Referenced_Document_Reference_Type_Code
	Business Requirement 08/09/2008 CSC REF0012 0..1 Document type
0 .. 1	CI_Referenced_Document_Global_Identifier_Identifier
	Business Requirement 08/09/2008 CSC REF0007 0..1 Reference GUID
0 .. 1	CI_Referenced_Document_Revision_Identifier_Identifier
	Business Requirement 08/09/2008 CSC REF0005 0..1 Reference index ID
0 .. unbounded	CI_Referenced_Document_Name_Text
	Business Requirement 13/07/2009 Catalogue CAM0420 0..1 Product marketing campaign name
0 .. unbounded	CI_Referenced_Document_Information_Text
0 .. unbounded	CI_Referenced_Document_Previous_Revision_Identifier_Identifier
0 .. unbounded	CI_Referenced_Document_Section_Name_Text
0 .. 1	CI_Referenced_Document_Issuer_CI_Trade_Party Main::CI_Trade_Party_Details
	Business Requirement 12/07/2008 CSC REF0011 0..1 Referenced document issuer party
0 .. unbounded	CI_Referenced_Document_Attached_Specified_Binary_File Main::Specified_Binary_File_Details
	Business Requirement 15/05/2009 CSC REF0014 0..* Attached Binary File
0 .. 1	CI_Referenced_Document_Effective_CI_Specified_Period Main::CI_Specified_Period_Details

Occurrence	Element/Attribute
	Business Requirement
	13/07/2009 Catalogue CAM0421 0..1 Product Marketing campaign period
0 .. unbounded	Catalogue_Trade_Product.Presentation.Specified_Binary File Main::Specified_Binary File. Details
	Business Requirement
	03/06/2009 Catalogue CAI0107 0..* Multimedia presentation
0 .. unbounded	Catalogue_Trade_Product.Applicable.Keyword Main::Keyword. Details
0 .. unbounded	Keyword.Name.Text
	Business Requirement
	03/06/2009 Catalogue CAI0110 0..* Keyword
0 .. unbounded	Catalogue_Trade_Product.Attached.Product_Security Tag Main::Product_Security Tag. Details
0 .. 1	Product_Security Tag.Type.Code
	Business Requirement
	13/07/2009 Catalogue PRO0348 0..1 Security tag type Code
0 .. 1	Product_Security Tag.Location.Code
	Business Requirement
	13/07/2009 Catalogue PRO0349 0..1 Security tag location Code
0 .. unbounded	Catalogue_Trade_Product.Marketing.Trade Product_Feature Main::Trade Product_Feature. Details
	Business Requirement
	13/07/2009 Catalogue MAR0416 0..n Marketing Feature
0 .. 1	Trade Product_Feature.Identification.Identifier
0 .. unbounded	Trade Product_Feature.Description.Text
0 .. unbounded	Trade Product_Feature.Name.Text
0 .. 1	Trade Product_Feature.Type.Code
	Business Requirement
	13/07/2009 Catalogue MAF0550 0..1 Marketing Feature type
0 .. unbounded	Trade Product_Feature.Marketing Phrase.Text
0 .. unbounded	Trade Product_Feature.Marketing.Measure
0 .. unbounded	Catalogue_Trade_Product.MSDS_Reference.CI_Referenced_Document Main::CI_Referenced_Document. Details
	Business Requirement
	13/08/2009 Catalogue HZI0510 0..n Material Safety Data Sheet
0 .. unbounded	Catalogue_Trade_Product.Additional_Reference.CI_Referenced_Document Main::CI_Referenced_Document. Details
	Business Requirement
	03/06/2009 Catalogue CAI0108 0..1 Additional information (reference)
	13/07/2009 Catalogue PRO0360 0..n Product Information Representation Reference
	13/07/2009 Catalogue MAR0401 0..1 Additional Marketing Document
0 .. unbounded	Catalogue_Trade_Product.Information.CI_Note Main::CI_Note. Details
	Business Requirement
	13/08/2009 Catalogue PRO0330 0..* Additional Product Description
0 .. unbounded	CICL_Supply Chain_Trade Line Item.Substitute_Applicable.CI_Referenced_Product Main::CI_Referenced_Product. Details
	Business Requirement
	12/07/2009 Catalogue CAI0111 0..* Replacing catalogue item
0 .. unbounded	CICL_Supply Chain_Trade Line Item.Accessory_Applicable.CI_Referenced_Product Main::CI_Referenced_Product. Details
	Business Requirement
	12/07/2009 Catalogue CAI0112 0..* Accessory product
0 .. unbounded	CI_Referenced_Product.Identification.Identifier
0 .. unbounded	CI_Referenced_Product.Global_Identifier.Identifier
	Business Requirement
	14/08/2009 Catalogue APR0530 at least one ID Product Identification of a related

Occurrence	Element/Attribute
	Business Requirement
0 .. 1	<p><i>CI_Referenced_Product.Seller Assigned_Identification.Identifier</i> Business Requirement 14/08/2009 Catalogue APR0530 at least one ID Product Identification of a related product</p> <p>must be provided (0..1 in CCL)</p>
0 .. 1	<p><i>CI_Referenced_Product.Buyer Assigned_Identification.Identifier</i> Business Requirement 14/08/2009 Catalogue APR0530 at least one ID Product Identification of a related product</p> <p>must be provided (0..1)</p>
0 .. 1	<p><i>CI_Referenced_Product.Manufacturer Assigned_Identification.Identifier</i> Business Requirement 14/08/2009 Catalogue APR0530 at least one ID Product Identification of a related product</p> <p>must be provided (0..1)</p>
0 .. 1	<p><i>CI_Referenced_Product.Industry Assigned_Identification.Identifier</i> Business Requirement 14/08/2009 Catalogue APR0530 at least one ID Product Identification of a related product</p> <p>must be provided (0..1)</p>
0 .. unbounded	<i>CI_Referenced_Product.Description.Text</i>
0 .. unbounded	<i>CI_Referenced_Product.Relationship_Type.Code</i>
0 .. unbounded	<i>CI_Referenced_Product.Unit.Quantity</i>
0 .. unbounded	CICL_Supply Chain_Trade Line Item.Component_Applicable_CI_Referenced_Product
	Main::CI_Referenced_Product.Details
	Business Requirement
0 .. unbounded	<p>12/07/2009 Catalogue CAI0115 0..* Component product</p> <p><i>CI_Referenced_Product.Identification.Identifier</i> Business Requirement 14/08/2009 Catalogue APR0530 at least one ID Product Identification of a related product</p> <p>must be provided (0..1)</p>
0 .. unbounded	<p><i>CI_Referenced_Product.Global_Identification.Identifier</i> Business Requirement 14/08/2009 Catalogue APR0530 at least one ID Product Identification of a related product</p> <p>must be provided (0..1)</p>
0 .. 1	<p><i>CI_Referenced_Product.Seller Assigned_Identification.Identifier</i> Business Requirement 14/08/2009 Catalogue APR0530 at least one ID Product Identification of a related product</p> <p>must be provided (0..1)</p>
0 .. 1	<p><i>CI_Referenced_Product.Buyer Assigned_Identification.Identifier</i> Business Requirement 14/08/2009 Catalogue APR0530 at least one ID Product Identification of a related product</p> <p>must be provided (0..1)</p>
0 .. 1	<p><i>CI_Referenced_Product.Manufacturer Assigned_Identification.Identifier</i></p> <p>must be provided (0..1)</p>

Occurrence	Element/Attribute
	Business Requirement
	14/08/2009 Catalogue APR0530 at least one ID Product Identification of a related product
0 .. 1	<ul style="list-style-type: none"> must be provided (0..1) CI_Referenced_Product. Industry Assigned_ Identification. Identifier
	Business Requirement
	14/08/2009 Catalogue APR0530 at least one ID Product Identification of a related product
0 .. unbounded	<ul style="list-style-type: none"> must be provided (0..1) CI_Referenced_Product. Description. Text CI_Referenced_Product. Relationship_Type. Code CI_Referenced_Product. Unit. Quantity
	Business Requirement
	14/08/2009 Catalogue APR0532 0..1 Related item quantity
0 .. unbounded	CICL_Supply Chain_ Trade Line Item. Complementary_ Applicable. CI_Referenced_Product
	Main::CI_Referenced_Product. Details
	Business Requirement
	12/07/2009 Catalogue CAI0114 0..* Complementary product
0 .. unbounded	CI_Referenced_Product. Identification. Identifier
	Business Requirement
	14/08/2009 Catalogue APR0530 at least one ID Product Identification of a related product
0 .. unbounded	<ul style="list-style-type: none"> must be provided (0..1) CI_Referenced_Product. Global_ Identification. Identifier
	Business Requirement
	14/08/2009 Catalogue APR0530 at least one ID Product Identification of a related product
0 .. 1	<ul style="list-style-type: none"> must be provided (0..1) CI_Referenced_Product. Seller Assigned_ Identification. Identifier
	Business Requirement
	14/08/2009 Catalogue APR0530 at least one ID Product Identification of a related product
0 .. 1	<ul style="list-style-type: none"> must be provided (0..1) CI_Referenced_Product. Buyer Assigned_ Identification. Identifier
	Business Requirement
	14/08/2009 Catalogue APR0530 at least one ID Product Identification of a related product
0 .. 1	<ul style="list-style-type: none"> must be provided (0..1) CI_Referenced_Product. Manufacturer Assigned_ Identification. Identifier
	Business Requirement
	14/08/2009 Catalogue APR0530 at least one ID Product Identification of a related product
0 .. 1	<ul style="list-style-type: none"> must be provided (0..1) CI_Referenced_Product. Industry Assigned_ Identification. Identifier
	Business Requirement
	14/08/2009 Catalogue APR0530 at least one ID Product Identification of a related product
0 .. unbounded	<ul style="list-style-type: none"> must be provided (0..1) CI_Referenced_Product. Description. Text CI_Referenced_Product. Relationship_Type. Code CI_Referenced_Product. Unit. Quantity
	Business Requirement
	14/08/2009 Catalogue APR0532 0..1 Related item quantity

Occurrence	Element/Attribute
0 .. unbounded	CICL_Supply Chain_Trade Line Item. Additional_Applicable_CI_Referenced_Product Main::CI_Referenced_Product. Details
	Business Requirement
	12/07/2009 Catalogue CAI0116 0..* Additional product
0 .. unbounded	CI_Referenced_Product. Identification. Identifier Business Requirement
	14/08/2009 Catalogue APR0530 at least one ID Product Identification of a related product
	must be provided (0..1)
0 .. unbounded	CI_Referenced_Product. Global_ Identification. Identifier Business Requirement
	14/08/2009 Catalogue APR0530 at least one ID Product Identification of a related product
	must be provided (0..1)
0 .. 1	CI_Referenced_Product. Seller Assigned_ Identification. Identifier Business Requirement
	14/08/2009 Catalogue APR0530 at least one ID Product Identification of a related product
	must be provided (0..1)
0 .. 1	CI_Referenced_Product. Buyer Assigned_ Identification. Identifier Business Requirement
	14/08/2009 Catalogue APR0530 at least one ID Product Identification of a related product
	must be provided (0..1)
0 .. 1	CI_Referenced_Product. Manufacturer Assigned_ Identification. Identifier Business Requirement
	14/08/2009 Catalogue APR0530 at least one ID Product Identification of a related product
	must be provided (0..1)
0 .. 1	CI_Referenced_Product. Industry Assigned_ Identification. Identifier Business Requirement
	14/08/2009 Catalogue APR0530 at least one ID Product Identification of a related product
	must be provided (0..1)
0 .. unbounded	CI_Referenced_Product. Description. Text Business Requirement
	14/08/2009 Catalogue APR0533 0:1 Additional information (textual
0 .. unbounded	CI_Referenced_Product. Relationship_Type. Code Business Requirement
	14/08/2009 Catalogue APR0531 1..1 Relationship Type
0 .. unbounded	CI_Referenced_Product. Unit. Quantity Business Requirement
	14/08/2009 Catalogue APR0532 0..1 Related item quantity

7.2.2. Common ABIEs

Occurrence	Element/Attribute
	Branch_Financial Institution. Details
0 .. 1	Branch_Financial Institution. Identification. Identifier Business Requirement
	15/05/2009 CSC FIB0001 0..1 Branch identification
0 .. 1	Branch_Financial Institution. Name. Text

0 .. 1	Business Requirement	15/05/2009	CSC	FIB0002	0..1	Institution Branch name
	Branch_ Financial Institution. Location. Financial Institution_ Address					
	Main::Financial Institution_ Address. Details					
	Business Requirement	15/05/2009	CSC	FIB0003	0..1	Address

Occurrence	Element/Attribute
	CI_Creditor_Financial Account. Details
0 .. 1	<ul style="list-style-type: none"> — <i>CI_Creditor_Financial Account. IBAN_ Identification. Identifier</i> <ul style="list-style-type: none"> Business Requirement 08/09/2008 CSC FAC0001 0..1 IBAN number
0 .. 1	<ul style="list-style-type: none"> — <i>CI_Creditor_Financial Account. Account Name. Text</i> <ul style="list-style-type: none"> Business Requirement 12/07/2008 CSC FAC0016 0..1 Name
0 .. 1	<ul style="list-style-type: none"> — <i>CI_Creditor_Financial Account. Proprietary_ Identification. Identifier</i> <ul style="list-style-type: none"> Business Requirement 07/11/2008 CSC FAC0010 0..1 Financial Account Proprietary Identification

Occurrence	Element/Attribute
	CI_Creditor_Financial Institution. Details
0 .. 1	<ul style="list-style-type: none"> — <i>CI_Creditor_Financial Institution. BIC_Identifier</i> <ul style="list-style-type: none"> Business Requirement 07/11/2008 CSC FIN0002 0..1 BIC identification
0 .. 1	— <i>CI_Creditor_Financial Institution. Clearing System Name_Text</i>
0 .. 1	<ul style="list-style-type: none"> — <i>CI_Creditor_Financial Institution. CHIPS Universal_Identifier</i> <ul style="list-style-type: none"> Business Requirement 15/05/2009 CSC FIN0001 0..1 Alternative bank identification
0 .. 1	<ul style="list-style-type: none"> — <i>CI_Creditor_Financial Institution. New Zealand NCC_Identifier</i> <ul style="list-style-type: none"> Business Requirement 15/05/2009 CSC FIN0001 0..1 Alternative bank identification
0 .. 1	<ul style="list-style-type: none"> — <i>CI_Creditor_Financial Institution. Irish NSC_Identifier</i> <ul style="list-style-type: none"> Business Requirement 15/05/2009 CSC FIN0001 0..1 Alternative bank identification
0 .. 1	<ul style="list-style-type: none"> — <i>CI_Creditor_Financial Institution. UK Sort Code_Identifier</i> <ul style="list-style-type: none"> Business Requirement 15/05/2009 CSC FIN0001 0..1 Alternative bank identification
0 .. 1	<ul style="list-style-type: none"> — <i>CI_Creditor_Financial Institution. CHIPS Participant_Identifier</i> <ul style="list-style-type: none"> Business Requirement 15/05/2009 CSC FIN0001 0..1 Alternative bank identification
0 .. 1	<ul style="list-style-type: none"> — <i>CI_Creditor_Financial Institution. Swiss BC_Identifier</i> <ul style="list-style-type: none"> Business Requirement 15/05/2009 CSC FIN0001 0..1 Alternative bank identification
0 .. 1	<ul style="list-style-type: none"> — <i>CI_Creditor_Financial Institution. Fedwire Routing Number_Identifier</i> <ul style="list-style-type: none"> Business Requirement 15/05/2009 CSC FIN0001 0..1 Alternative bank identification
0 .. 1	<ul style="list-style-type: none"> — <i>CI_Creditor_Financial Institution. Portuguese NCC_Identifier</i> <ul style="list-style-type: none"> Business Requirement 15/05/2009 CSC FIN0001 0..1 Alternative bank identification
0 .. 1	<ul style="list-style-type: none"> — <i>CI_Creditor_Financial Institution. Russian Central Bank_Identifier</i> <ul style="list-style-type: none"> Business Requirement 15/05/2009 CSC FIN0001 0..1 Alternative bank identification
0 .. 1	<ul style="list-style-type: none"> — <i>CI_Creditor_Financial Institution. Italian Domestic_Identifier</i> <ul style="list-style-type: none"> Business Requirement 15/05/2009 CSC FIN0001 0..1 Alternative bank identification
0 .. 1	<ul style="list-style-type: none"> — <i>CI_Creditor_Financial Institution. Austrian Bankleitzahl_Identifier</i> <ul style="list-style-type: none"> Business Requirement 15/05/2009 CSC FIN0001 0..1 Alternative bank identification
0 .. 1	<ul style="list-style-type: none"> — <i>CI_Creditor_Financial Institution. Canadian Payments Association_Identifier</i> <ul style="list-style-type: none"> Business Requirement 15/05/2009 CSC FIN0001 0..1 Alternative bank identification
0 .. 1	<ul style="list-style-type: none"> — <i>CI_Creditor_Financial Institution. SIC_Identifier</i> <ul style="list-style-type: none"> Business Requirement 15/05/2009 CSC FIN0001 0..1 Alternative bank identification
0 .. 1	<ul style="list-style-type: none"> — <i>CI_Creditor_Financial Institution. German Bankleitzahl_Identifier</i> <ul style="list-style-type: none"> Business Requirement 15/05/2009 CSC FIN0001 0..1 Alternative bank identification
0 .. 1	<ul style="list-style-type: none"> — <i>CI_Creditor_Financial Institution. Spanish Domestic Interbanking_Identifier</i> <ul style="list-style-type: none"> Business Requirement 15/05/2009 CSC FIN0001 0..1 Alternative bank identification
0 .. 1	<ul style="list-style-type: none"> — <i>CI_Creditor_Financial Institution. South African NCC_Identifier</i> <ul style="list-style-type: none"> Business Requirement 15/05/2009 CSC FIN0001 0..1 Alternative bank identification
0 .. 1	<ul style="list-style-type: none"> — <i>CI_Creditor_Financial Institution. Hong Kong Bank_Identifier</i> <ul style="list-style-type: none"> Business Requirement 15/05/2009 CSC FIN0001 0..1 Alternative bank identification
0 .. 1	<ul style="list-style-type: none"> — <i>CI_Creditor_Financial Institution. Australian BSB_Identifier</i> <ul style="list-style-type: none"> Business Requirement 15/05/2009 CSC FIN0001 0..1 Alternative bank identification
0 .. 1	<ul style="list-style-type: none"> — <i>CI_Creditor_Financial Institution. Indian Financial System_Identifier</i>

Occurrence	Element/Attribute
	Business Requirement
0 .. 1	15/05/2009 CSC FIN0001 0..1 Alternative bank identification CI_Creditor_Financial Institution. Hellenic Bank_ Identification. Identifier
	Business Requirement
0 .. 1	15/05/2009 CSC FIN0001 0..1 Alternative bank identification CI_Creditor_Financial Institution. Polish National Clearing_ Identification. Identifi
	Business Requirement
0 .. 1	15/05/2009 CSC FIN0001 0..1 Alternative bank identification CI_Creditor_Financial Institution. Name. Text
	Business Requirement
0 .. 1	07/11/2008 CSC FIN0003 0..1 Institution name CI_Creditor_Financial Institution. Location. Financial Institution_ Address Main::Financial Institution_ Address. Details
	Business Requirement
0 .. 1	07/11/2008 CSC FIN0004 0..1 Address - mapped to Financial Institution CI_Creditor_Financial Institution. Sub-Division. Branch_ Financial Institution Main::Branch_ Financial Institution. Details
	Business Requirement
	07/11/2008 CSC FIN0005 0..1 Financial Institution branch

Occurrence	Element/Attribute
	CI_Debtor_Financial Account. Details
0 .. 1	<ul style="list-style-type: none"> — <i>CI_Debtor_Financial Account. IBAN_ Identification. Identifier</i> <ul style="list-style-type: none"> Business Requirement 12/07/2008 CSC FAC0001 0..1 IBAN number
0 .. 1	<ul style="list-style-type: none"> — <i>CI_Debtor_Financial Account. Account Name. Text</i> <ul style="list-style-type: none"> Business Requirement 12/07/2008 CSC FAC0016 0..1 Name
0 .. 1	<ul style="list-style-type: none"> — <i>CI_Debtor_Financial Account. Proprietary_ Identification. Identifier</i> <ul style="list-style-type: none"> Business Requirement 07/11/2008 CSC FAC0010 0..1 Financial Account Proprietary Identification

Occurrence	Element/Attribute
	CI_Debtor_Financial Institution. Details
0 .. 1	<ul style="list-style-type: none"> — <i>CI_Debtor_Financial Institution. BIC. Identifier</i> Business Requirement 07/11/2008 CSC FIN0002 0..1 BIC identification
0 .. 1	<ul style="list-style-type: none"> — <i>CI_Debtor_Financial Institution. Clearing System Name. Text</i>
0 .. 1	<ul style="list-style-type: none"> — <i>CI_Debtor_Financial Institution. CHIPS Universal_ Identification. Identifier</i> Business Requirement 15/05/2009 CSC FIN0001 0..1 Alternative bank identification
0 .. 1	<ul style="list-style-type: none"> — <i>CI_Debtor_Financial Institution. New Zealand NCC_ Identification. Identifier</i> Business Requirement 15/05/2009 CSC FIN0001 0..1 Alternative bank identification
0 .. 1	<ul style="list-style-type: none"> — <i>CI_Debtor_Financial Institution. Irish NSC_ Identification. Identifier</i> Business Requirement 15/05/2009 CSC FIN0001 0..1 Alternative bank identification
0 .. 1	<ul style="list-style-type: none"> — <i>CI_Debtor_Financial Institution. UK Sort Code_ Identification. Identifier</i> Business Requirement 15/05/2009 CSC FIN0001 0..1 Alternative bank identification
0 .. 1	<ul style="list-style-type: none"> — <i>CI_Debtor_Financial Institution. CHIPS Participant_ Identification. Identifier</i> Business Requirement 15/05/2009 CSC FIN0001 0..1 Alternative bank identification
0 .. 1	<ul style="list-style-type: none"> — <i>CI_Debtor_Financial Institution. Swiss BC_ Identification. Identifier</i> Business Requirement 15/05/2009 CSC FIN0001 0..1 Alternative bank identification
0 .. 1	<ul style="list-style-type: none"> — <i>CI_Debtor_Financial Institution. Fedwire Routing Number_ Identification. Identif</i> Business Requirement 15/05/2009 CSC FIN0001 0..1 Alternative bank identification
0 .. 1	<ul style="list-style-type: none"> — <i>CI_Debtor_Financial Institution. Portuguese NCC_ Identification. Identifier</i> Business Requirement 15/05/2009 CSC FIN0001 0..1 Alternative bank identification
0 .. 1	<ul style="list-style-type: none"> — <i>CI_Debtor_Financial Institution. Russian Central Bank_ Identification. Identifier</i> Business Requirement 15/05/2009 CSC FIN0001 0..1 Alternative bank identification
0 .. 1	<ul style="list-style-type: none"> — <i>CI_Debtor_Financial Institution. Italian Domestic_ Identification. Identifier</i> Business Requirement 15/05/2009 CSC FIN0001 0..1 Alternative bank identification
0 .. 1	<ul style="list-style-type: none"> — <i>CI_Debtor_Financial Institution. Austrian Bankleitzahl_ Identification. Identifier</i> Business Requirement 15/05/2009 CSC FIN0001 0..1 Alternative bank identification
0 .. 1	<ul style="list-style-type: none"> — <i>CI_Debtor_Financial Institution. Canadian Payments Association_ Identification</i> Business Requirement 15/05/2009 CSC FIN0001 0..1 Alternative bank identification
0 .. 1	<ul style="list-style-type: none"> — <i>CI_Debtor_Financial Institution. SIC_ Identification. Identifier</i> Business Requirement 15/05/2009 CSC FIN0001 0..1 Alternative bank identification
0 .. 1	<ul style="list-style-type: none"> — <i>CI_Debtor_Financial Institution. German Bankleitzahl_ Identification. Identifier</i> Business Requirement 15/05/2009 CSC FIN0001 0..1 Alternative bank identification
0 .. 1	<ul style="list-style-type: none"> — <i>CI_Debtor_Financial Institution. Spanish Domestic Interbanking_ Identification.</i> Business Requirement 15/05/2009 CSC FIN0001 0..1 Alternative bank identification
0 .. 1	<ul style="list-style-type: none"> — <i>CI_Debtor_Financial Institution. South African NCC_ Identification. Identifier</i> Business Requirement 15/05/2009 CSC FIN0001 0..1 Alternative bank identification
0 .. 1	<ul style="list-style-type: none"> — <i>CI_Debtor_Financial Institution. Hong Kong Bank_ Identification. Identifier</i> Business Requirement 15/05/2009 CSC FIN0001 0..1 Alternative bank identification
0 .. 1	<ul style="list-style-type: none"> — <i>CI_Debtor_Financial Institution. Australian BSB_ Identification. Identifier</i> Business Requirement 15/05/2009 CSC FIN0001 0..1 Alternative bank identification
0 .. 1	<ul style="list-style-type: none"> — <i>CI_Debtor_Financial Institution. Indian Financial System_ Identification. Identifi</i>

Occurrence	Element/Attribute
	Business Requirement
0 .. 1	15/05/2009 CSC FIN0001 0..1 Alternative bank identification CI_Debtor_Financial Institution. Hellenic Bank_ Identification. Identifier
	Business Requirement
0 .. 1	15/05/2009 CSC FIN0001 0..1 Alternative bank identification CI_Debtor_Financial Institution. Polish National Clearing_ Identification. Identifi
	Business Requirement
0 .. 1	15/05/2009 CSC FIN0001 0..1 Alternative bank identification CI_Debtor_Financial Institution. Name. Text
	Business Requirement
0 .. 1	07/11/2008 CSC FIN0003 0..1 Institution name CI_Debtor_Financial Institution. Location. Financial Institution_ Address Main::Financial Institution_ Address. Details
	Business Requirement
0 .. 1	07/11/2008 CSC FIN0004 0..1 Address - mapped to Financial Institution CI_Debtor_Financial Institution. Sub-Division. Branch_ Financial Institution Main::Branch_ Financial Institution. Details
	Business Requirement
	07/11/2008 CSC FIN0005 0..1 Financial Institution branch

Occurrence	Element/Attribute
CI_Delivery_Adjustment_Details	
0 .. 1	<ul style="list-style-type: none"> — <i>CI_Delivery_Adjustment.Reason.Code</i> Business Requirement 08/09/2008 CSC DLA0004 0..* 0..1 in workbase
0 .. unbounded	<ul style="list-style-type: none"> — <i>CI_Delivery_Adjustment.Reason.Text</i> Business Requirement 08/09/2008 CSC DLA0005 0..* 0..1 in workbase
0 .. unbounded	<ul style="list-style-type: none"> — <i>CI_Delivery_Adjustment.Actual.Amount</i> Business Requirement 08/09/2008 CSC DLA0001 0..* 0..1 in workbase
0 .. 1	<ul style="list-style-type: none"> — <i>CI_Delivery_Adjustment.Actual.Quantity</i> Business Requirement 08/09/2008 CSC DLA0002 0..1 0..1
0 .. 1	<ul style="list-style-type: none"> — <i>CI_Delivery_Adjustment.Actual.Date Time</i> Business Requirement 08/09/2008 CSC DLA0003 0..1 Date Time

Occurrence	Element/Attribute
	CI_Delivery_Instructions. Details
0 .. unbounded	<ul style="list-style-type: none"> — <i>CI_Delivery_Instructions. Handling. Code</i> Business Requirement 08/09/2008 CSC DLI0003 0..* 0..1 in workbase
0 .. unbounded	<ul style="list-style-type: none"> — <i>CI_Delivery_Instructions. Handling. Text</i> Business Requirement 08/09/2008 CSC DLI0004 0..*
0 .. unbounded	<ul style="list-style-type: none"> — <i>CI_Delivery_Instructions. Description. Text</i> Business Requirement 08/09/2008 CSC DLI0001 0..*
0 .. 1	<ul style="list-style-type: none"> — <i>CI_Delivery_Instructions. Description. Code</i> Business Requirement 08/09/2008 CSC DLI0002 0..* 0..1 in workbase

Occurrence	Element/Attribute
	CI_ Document Context_ Parameter. Details
0 .. 1	CI_ Document Context_ Parameter. Identification. Identifier
0 .. 1	CI_ Document Context_ Parameter. Value. Text
0 .. 1	CI_ Document Context_ Parameter. Specified. CI_ Document_ Version
	Main::CI_ Document_ Version. Details

Occurrence	Element/Attribute
	CI_Document_Version_Details
0 .. 1	└ CI_Document_Version_Identification_Identifier
0 .. 1	└ CI_Document_Version_Name_Text
0 .. 1	└ CI_Document_Version_Issue_Date_Time

Occurrence	Element/Attribute
CI_Financial_Adjustment_Details	
0 .. 1	<ul style="list-style-type: none"> — <i>CI_Financial_Adjustment.Reason.Code</i> Business Requirement 08/09/2008 CSC FLA0003 0..* Reason Code: Cardinality changed to 0:1
0 .. unbounded	<ul style="list-style-type: none"> — <i>CI_Financial_Adjustment.Reason.Text</i> Business Requirement 08/09/2008 CSC FLA0004 0..* Reason text
0 .. unbounded	<ul style="list-style-type: none"> — <i>CI_Financial_Adjustment.Actual.Amount</i> Business Requirement 08/09/2008 CSC FLA0001 0..* Actual amount
0 .. 1	— <i>CI_Financial_Adjustment.Actual.Quantity</i>
0 .. 1	<ul style="list-style-type: none"> — <i>CI_Financial_Adjustment.Actual.Date Time</i> Business Requirement 08/09/2008 CSC FLA0002 0..1 Date time

Occurrence	Element/Attribute
	CI_ Geographical Coordinate. Details
0 .. 1	<ul style="list-style-type: none"> — <i>CI_ Geographical Coordinate. Altitude. Measure</i> Business Requirement 13/07/2008 CSC GEO0001 0..1 Geographical Coordinate Altitude
0 .. 1	<ul style="list-style-type: none"> — <i>CI_ Geographical Coordinate. Latitude. Measure</i> Business Requirement 13/07/2008 CSC GEO0002 0..1 Geographical Coordinate Latitude Measure
0 .. 1	<ul style="list-style-type: none"> — <i>CI_ Geographical Coordinate. Longitude. Measure</i> Business Requirement 13/07/2008 CSC GEO0003 0..1 Geographical Coordinate Longitude Measure - Circular degree qDT
0 .. 1	<ul style="list-style-type: none"> — <i>CI_ Geographical Coordinate. System. Identifier</i> Business Requirement 13/07/2008 CSC GEO0006 0..1 Geographical Coordinate System Identifier

Occurrence	Element/Attribute
	CI_Handling_Instructions. Details
0 .. unbounded	<ul style="list-style-type: none"> — <i>CI_Handling_Instructions. Handling. Code</i> <ul style="list-style-type: none"> Business Requirement 09/09/2008 CSC HLI0001 0..* Handling code
0 .. unbounded	<ul style="list-style-type: none"> — <i>CI_Handling_Instructions. Procedure. Text</i> <ul style="list-style-type: none"> Business Requirement 09/09/2008 CSC HLI0004 0..* Procedure
0 .. unbounded	<ul style="list-style-type: none"> — <i>CI_Handling_Instructions. Description. Text</i> <ul style="list-style-type: none"> Business Requirement 09/09/2008 CSC HLI0002 0..* Description
0 .. unbounded	<ul style="list-style-type: none"> — <i>CI_Handling_Instructions. Description. Code</i> <ul style="list-style-type: none"> Business Requirement 09/09/2008 CSC HLI0003 0..* Description code
0 .. 1	— <i>CI_Handling_Instructions. Maximum Stackability Weight_ Applicable. Measure</i>
0 .. 1	— <i>CI_Handling_Instructions. Maximum Stackability_ Applicable. Quantity</i>
0 .. unbounded	<ul style="list-style-type: none"> — CI_Handling_Instructions. Handling_ Applicable. Transport Setting_ Temperature Main::Transport Setting_ Temperature. Details

Occurrence	Element/Attribute
	CI_Legal_Organization. Details
0 .. 1	<ul style="list-style-type: none"> — <i>CI_Legal_Organization. Legal Classification. Code</i> Business Requirement 13/07/2008 CSC PAR0013 0..1 Party Legal Classification Code
0 .. 1	<ul style="list-style-type: none"> — <i>CI_Legal_Organization. Name. Text</i> Business Requirement 13/07/2008 CSC PAR0012 0..1 Party Legal Entity Registration
0 .. 1	<ul style="list-style-type: none"> — <i>CI_Legal_Organization. Identification. Identifier</i> Business Requirement 13/07/2008 CSC PAR0011 0..1 Party Legal Entity Identification
0 .. 1	<ul style="list-style-type: none"> — CI_Legal_Organization. Postal. CI_Trade_Address Main::CI_Trade_Address. Details Business Requirement 13/07/2008 CSC PAR0015 0..1 Party Legal Entity Registration Address - maybe a specific ASCC with PT Registration should be added as
0 .. unbounded	<ul style="list-style-type: none"> — CI_Legal_Organization. Authorized. CI_Legal_Registration Main::CI_Legal_Registration. Details

Occurrence	Element/Attribute
	CI_Legal_Registration. Details
0 .. 1	<ul style="list-style-type: none"> — <i>CI_Legal_Registration. Type. Code</i> Business Requirement 13/07/2008 CSC PAR0014 0..1 Party Legal Corporate Registration Scheme: cardinality changed to 0..* 20MAR09
0 .. 1	<ul style="list-style-type: none"> — <i>CI_Legal_Registration. Identification. Identifier</i> Business Requirement 13/07/2008 CSC PAR0003 0..* Party Tax Identifier

Occurrence	Element/Attribute
	CI_ Logistics_ Location. Details
0 .. 1	<ul style="list-style-type: none"> CI_ Logistics_ Location. Identification. Identifier <ul style="list-style-type: none"> Business Requirement 13/07/2008 CSC LOC0001 0..1 Location identification
0 .. unbounded	<ul style="list-style-type: none"> CI_ Logistics_ Location. Name. Text <ul style="list-style-type: none"> Business Requirement 13/07/2008 CSC LOC0003 0..* Location Name Text
0 .. 1	<ul style="list-style-type: none"> CI_ Logistics_ Location. Type. Code <ul style="list-style-type: none"> Business Requirement 13/07/2008 CSC LOC0004 0..* Location Type Code : cardinality changed
0 .. unbounded	<ul style="list-style-type: none"> CI_ Logistics_ Location. Description. Text <ul style="list-style-type: none"> Business Requirement 13/07/2008 CSC LOC0002 0..1 Location description
0 .. 1	CI_ Logistics_ Location. Postal. CI_ Trade_ Address
	<ul style="list-style-type: none"> Main::CI_ Trade_ Address. Details <ul style="list-style-type: none"> Business Requirement 13/07/2008 CSC LOC0007 0..1 Location Address Terms Country
0 .. 1	CI_ Logistics_ Location. Physical. CI_ Geographical Coordinate
	<ul style="list-style-type: none"> Main::CI_ Geographical Coordinate. Details

Occurrence	Element/Attribute
CI_Logistics_Service Charge. Details	
0 .. 1	CI_Logistics_Service Charge. Identification. Identifier
0 .. unbounded	CI_Logistics_Service Charge. Description. Text
0 .. 1	CI_Logistics_Service Charge. Payment Arrangement. Code
0 .. 1	CI_Logistics_Service Charge. Tariff Class. Code
0 .. 1	CI_Logistics_Service Charge. Charge_Category. Code
0 .. 1	CI_Logistics_Service Charge. Service_Category. Code
0 .. unbounded	CI_Logistics_Service Charge. Disbursement. Amount
0 .. unbounded	CI_Logistics_Service Charge. Applied. Amount
0 .. 1	CI_Logistics_Service Charge. Allowance Charge. Text
0 .. 1	CI_Logistics_Service Charge. Paying Party Role. Code
0 .. 1	CI_Logistics_Service Charge. Calculation Basis. Code
0 .. 1	CI_Logistics_Service Charge. Calculation Basis. Text
0 .. 1	CI_Logistics_Service Charge. Transport Payment Method. Code
0 .. 1	CI_Logistics_Service Charge. Payment Place. CI_Logistics_Location Main::CI_Logistics_Location. Details
0 .. 1	CI_Logistics_Service Charge. Applied From. CI_Logistics_Location Main::CI_Logistics_Location. Details
0 .. 1	CI_Logistics_Service Charge. Applied To. CI_Logistics_Location Main::CI_Logistics_Location. Details
0 .. unbounded	CI_Logistics_Service Charge. Applied. CI_Trade_Tax Main::CI_Trade_Tax. Details

Occurrence	Element/Attribute
	CI_Logistics_Transport Means. Details
0 .. 1	<ul style="list-style-type: none"> — <i>CI_Logistics_Transport Means. Type. Code</i> <ul style="list-style-type: none"> Business Requirement 13/07/2008 CSC TME0002 0..1 Transport Means Type Code
0 .. 1	<ul style="list-style-type: none"> — <i>CI_Logistics_Transport Means. Type. Text</i> <ul style="list-style-type: none"> Business Requirement 13/07/2008 CSC TME0003 0..1 Transport Means Type Text
0 .. 1	<ul style="list-style-type: none"> — <i>CI_Logistics_Transport Means. Identification. Identifier</i> <ul style="list-style-type: none"> Business Requirement 13/07/2008 CSC TME0001 0..1 Transport Means Identification (Transport Means Name mapping added for
0 .. 1	<ul style="list-style-type: none"> — <i>CI_Logistics_Transport Means. Name. Text</i> <ul style="list-style-type: none"> Business Requirement 13/07/2008 CSC TME0001 0..1 Transport Means Name (for maritime
0 .. 1	<ul style="list-style-type: none"> — CI_Logistics_Transport Means. Owner. CI_Trade_Party Main::CI_Trade_Party. Details

Occurrence	Element/Attribute
CI_Logistics_Transport Movement. Details	
0 .. 1	<ul style="list-style-type: none"> — <i>CI_Logistics_Transport Movement. Mode. Code</i> <li style="padding-left: 20px;">Business Requirement <li style="padding-left: 40px;">13/07/2008 CSC TMO0001 0..1 Mode Type Code
0 .. 1	<ul style="list-style-type: none"> — <i>CI_Logistics_Transport Movement. Mode. Text</i> <li style="padding-left: 20px;">Business Requirement <li style="padding-left: 40px;">13/07/2008 CSC TMO0002 0..1 Mode type description
0 .. 1	— <i>CI_Logistics_Transport Movement. Stage. Code</i>
0 .. 1	CI_Logistics_Transport Movement. Used. CI_Logistics_Transport Means Main::CI_Logistics_Transport Means. Details

Occurrence	Element/Attribute
	CI_Material_Goods Characteristic. Details
0 .. unbounded	<ul style="list-style-type: none"> — <i>CI_Material_Goods Characteristic. Description. Text</i> Business Requirement 13/07/2008 CSC MAT0004 0..* Material description
0 .. 1	<ul style="list-style-type: none"> — <i>CI_Material_Goods Characteristic. Type. Code</i> Business Requirement 13/07/2008 CSC MAT0001 0..1 Material type code
0 .. 1	<ul style="list-style-type: none"> — <i>CI_Material_Goods Characteristic. Proportional_ Constituent. Percent</i> Business Requirement 13/07/2008 CSC MAT0002 0..1 Material percentage
0 .. 1	<ul style="list-style-type: none"> — <i>CI_Material_Goods Characteristic. Absolute Presence_ Weight. Measure</i> Business Requirement 13/07/2008 CSC MAT0003 0..* Material weight quantity
0 .. 1	<ul style="list-style-type: none"> — <i>CI_Material_Goods Characteristic. Absolute Presence_ Volume. Measure</i> Business Requirement 13/07/2008 CSC MAT0003 0..* Material volume quantity

Occurrence	Element/Attribute				
CI_ Note. Details					
0 .. 1	CI_ Note. Subject. Text Business Requirement 13/07/2008 CSC	NOT0003	0..1		Note Subject Text :
0 .. 1	CI_ Note. Content. Code Business Requirement 13/07/2008 CSC	NOT0004	0..1		Note Content Code
0 .. unbounded	CI_ Note. Content. Text Business Requirement 13/07/2008 CSC changed to	NOT0005	0..1		Note Content Text : cardinality
0 .. 1	CI_ Note. Subject. Code Business Requirement 13/07/2008 CSC	NOT0002	0..1		Note Subject Code
0 .. 1	CI_ Note. Identification. Identifier Business Requirement 13/07/2008 CSC	NOT0001	0..1		Note Identifier

Occurrence	Element/Attribute
	CI_Packaging_Marking_Details
0 .. 1	— <i>CI_Packaging_Marking_Type.Code</i>
0 .. unbounded	— <i>CI_Packaging_Marking_Content.Text</i>
0 .. 1	— <i>CI_Packaging_Marking_Content.Date Time</i>
0 .. unbounded	— <i>CI_Packaging_Marking_Content.Amount</i>
0 .. unbounded	— <i>CI_Packaging_Marking_Barcode_Type.Code</i>

Occurrence	Element/Attribute
	CI_Product_Characteristic.Details
0 .. unbounded	— <i>CI_Product_Characteristic.Identification.Identifier</i>
0 .. 1	— <i>CI_Product_Characteristic.Type.Code</i>
0 .. unbounded	— <i>CI_Product_Characteristic.Description.Text</i>
0 .. 1	— <i>CI_Product_Characteristic.Value.Measure</i>
0 .. 1	— <i>CI_Product_Characteristic.Measurement.Method.Code</i>

Occurrence	Element/Attribute
	CI_Product_Classification. Details
0 .. 1	<i>CI_Product_Classification. System. Identifier</i>
0 .. unbounded	<i>CI_Product_Classification. System Name. Text</i>
0 .. 1	<i>CI_Product_Classification. Class. Code</i>
0 .. unbounded	<i>CI_Product_Classification. Class Name. Text</i>
0 .. 1	<i>CI_Product_Classification. Sub_Class. Code</i>
0 .. unbounded	CI_Product_Classification. Class. CI_Product_Characteristic
	Main::CI_Product_Characteristic. Details

Occurrence	Element/Attribute
	CI_ Referenced_ Document. Details
0 .. 1	<i>CI_ Referenced_ Document. Issuer Assigned_ Identification. Identifier</i> Business Requirement 12/07/2008 CSC REF0001 1..1 Reference number
0 .. 1	<i>CI_ Referenced_ Document. URI_ Identification. Identifier</i> Business Requirement 12/07/2008 CSC REF0006 0..1 Reference URI
0 .. 1	<i>CI_ Referenced_ Document. Issue. Date Time</i> Business Requirement 12/07/2008 CSC REF0003 0..1 Reference date
0 .. 1	<i>CI_ Referenced_ Document. Status. Code</i> Business Requirement 12/07/2008 CSC REF0004 0..1 Reference status
0 .. 1	<i>CI_ Referenced_ Document. Copy. Indicator</i> Business Requirement 12/07/2008 CSC REF0008 0..1 Copy indicator
0 .. 1	<i>CI_ Referenced_ Document. Line. Identifier</i> Business Requirement 12/07/2008 CSC REF0009 0..1 Reference line number
0 .. 1	<i>CI_ Referenced_ Document. Reference_ Type. Code</i> Business Requirement 08/09/2008 CSC REF0012 0..1 Document type
0 .. 1	<i>CI_ Referenced_ Document. Global_ Identification. Identifier</i> Business Requirement 08/09/2008 CSC REF0007 0..1 Reference GUID
0 .. 1	<i>CI_ Referenced_ Document. Revision_ Identification. Identifier</i> Business Requirement 08/09/2008 CSC REF0005 0..1 Reference index ID
0 .. unbounded	<i>CI_ Referenced_ Document. Name. Text</i> Business Requirement 12/07/2008 CSC REF0002 0..1 Reference Document Name
0 .. unbounded	<i>CI_ Referenced_ Document. Information. Text</i>
0 .. unbounded	<i>CI_ Referenced_ Document. Previous Revision_ Identification. Identifier</i>
0 .. unbounded	<i>CI_ Referenced_ Document. Section Name. Text</i>
0 .. 1	CI_ Referenced_ Document. Issuer. CI_ Trade_ Party Main::CI_ Trade_ Party. Details Business Requirement 12/07/2008 CSC REF0011 0..1 Referenced document issuer party
0 .. unbounded	CI_ Referenced_ Document. Attached. Specified_ Binary File Main::Specified_ Binary File. Details Business Requirement 15/05/2009 CSC REF0014 0..* Attached Binary File
0 .. 1	CI_ Referenced_ Document. Effective. CI_ Specified_ Period Main::CI_ Specified_ Period. Details

Occurrence	Element/Attribute
CI_ Referenced_ Product. Details	
0 .. unbounded	<i>CI_ Referenced_ Product. Identification. Identifier</i>
0 .. unbounded	<i>CI_ Referenced_ Product. Global_ Identification. Identifier</i>
0 .. 1	<i>CI_ Referenced_ Product. Seller Assigned_ Identification. Identifier</i>
0 .. 1	<i>CI_ Referenced_ Product. Buyer Assigned_ Identification. Identifier</i>
0 .. 1	<i>CI_ Referenced_ Product. Manufacturer Assigned_ Identification. Identifier</i>
0 .. 1	<i>CI_ Referenced_ Product. Industry Assigned_ Identification. Identifier</i>
0 .. unbounded	<i>CI_ Referenced_ Product. Description. Text</i>
0 .. unbounded	<i>CI_ Referenced_ Product. Relationship_ Type. Code</i>
0 .. unbounded	<i>CI_ Referenced_ Product. Unit. Quantity</i>

Occurrence	Element/Attribute
	CI_Registered_Tax_Details
0 .. 1	— <i>CI_Registered_Tax.Type.Code</i>
0 .. 1	— <i>CI_Registered_Tax.Exemption Reason.Code</i>
0 .. unbounded	— <i>CI_Registered_Tax.Exemption Reason.Text</i>
0 .. 1	— <i>CI_Registered_Tax.Currency.Code</i>
0 .. unbounded	— <i>CI_Registered_Tax.Jurisdiction.Text</i>
0 .. unbounded	— <i>CI_Registered_Tax.Description.Text</i>
0 .. 1	— <i>CI_Registered_Tax.Customs Duty.Indicator</i>

Occurrence	Element/Attribute
	CI_Spatial_Dimension. Details
0 .. 1	— <i>CI_Spatial_Dimension. Value. Measure</i>
0 .. 1	— <i>CI_Spatial_Dimension. Type. Code</i>
0 .. unbounded	— <i>CI_Spatial_Dimension. Description. Text</i>
0 .. 1	— <i>CI_Spatial_Dimension. Width. Measure</i>
0 .. 1	— <i>CI_Spatial_Dimension. Length. Measure</i>
0 .. 1	— <i>CI_Spatial_Dimension. Height. Measure</i>
0 .. 1	— <i>CI_Spatial_Dimension. Identification. Identifier</i>
0 .. 1	— <i>CI_Spatial_Dimension. Diameter. Measure</i>

Occurrence	Element/Attribute
	CI_Specified_Period_Details
0 .. unbounded	CI_Specified_Period.Duration.Measure
0 .. 1	CI_Specified_Period.Inclusive.Indicator
0 .. unbounded	CI_Specified_Period.Description.Text
0 .. 1	CI_Specified_Period.Start.Date Time
0 .. 1	CI_Specified_Period.End.Date Time
0 .. 1	CI_Specified_Period.Complete.Date Time
0 .. 1	CI_Specified_Period.Season.Code
0 .. 1	CI_Specified_Period.Identification.Identifier
0 .. unbounded	CI_Specified_Period.Name.Text
0 .. 1	CI_Specified_Period.Sequence.Numeric
0 .. 1	CI_Specified_Period.Start Date Flexibility.Code
0 .. 1	CI_Specified_Period.Continuous.Indicator

Occurrence	Element/Attribute
	CI_Supply Chain_Consignment_Details
0 .. unbounded	<i>CI_Supply Chain_Consignment.Associated Invoice.Amount</i>
0 .. 1	<i>CI_Supply Chain_Consignment.Declared Value For Customs.Amount</i>
0 .. 1	<i>CI_Supply Chain_Consignment.Total Charge.Amount</i>
0 .. 1	<i>CI_Supply Chain_Consignment.Package.Quantity</i>
0 .. unbounded	<i>CI_Supply Chain_Consignment.Gross Weight.Measure</i>
0 .. unbounded	<i>CI_Supply Chain_Consignment.Net Weight.Measure</i>
0 .. unbounded	<i>CI_Supply Chain_Consignment.Gross Volume.Measure</i>
0 .. 1	CI_Supply Chain_Consignment.Consignor.CI_Trade_Party Main::CI_Trade_Party.Details
0 .. 1	CI_Supply Chain_Consignment.Consignee.CI_Trade_Party Main::CI_Trade_Party.Details
0 .. 1	CI_Supply Chain_Consignment.Delivery.CI_Trade_Party Main::CI_Trade_Party.Details
0 .. unbounded	CI_Supply Chain_Consignment.Specified.CI_Logistics_Transport Movement Main::CI_Logistics_Transport Movement.Details
0 .. 1	CI_Supply Chain_Consignment.Customs Import Agent.CI_Trade_Party Main::CI_Trade_Party.Details
0 .. 1	CI_Supply Chain_Consignment.Customs Export Agent.CI_Trade_Party Main::CI_Trade_Party.Details
0 .. 1	CI_Supply Chain_Consignment.Carrier.CI_Trade_Party Main::CI_Trade_Party.Details
0 .. 1	CI_Supply Chain_Consignment.Transport Contract.CI_Referenced_Document Main::CI_Referenced_Document.Details
0 .. unbounded	CI_Supply Chain_Consignment.Utilized.CI_Logistics_Transport Equipment Main::CI_Logistics_Transport Equipment.Details
0 .. 1	CI_Supply Chain_Consignment.Freight Forwarder.CI_Trade_Party Main::CI_Trade_Party.Details
0 .. unbounded	CI_Supply Chain_Consignment.Grouping Centre.CI_Trade_Party Main::CI_Trade_Party.Details

Occurrence	Element/Attribute
CI_Supply Chain_Event. Details	
0 .. 1	CI_Supply Chain_Event. Identification. Identifier
0 .. 1	CI_Supply Chain_Event. Occurrence. Date Time
0 .. 1	CI_Supply Chain_Event. Type. Code
0 .. unbounded	CI_Supply Chain_Event. Description. Text
0 .. unbounded	CI_Supply Chain_Event. Description. Binary Object
0 .. 1	CI_Supply Chain_Event. Unit. Quantity
0 .. 1	CI_Supply Chain_Event. Latest_Occurrence. Date Time
0 .. 1	CI_Supply Chain_Event. Earliest_Occurrence. Date Time
0 .. 1	CI_Supply Chain_Event. Occurrence. CI_Specified_Period
	Main::CI_Specified_Period. Details
0 .. 1	CI_Supply Chain_Event. Occurrence. CI_Logistics_Location
	Main::CI_Logistics_Location. Details

Occurrence	Element/Attribute
	CI_Supply Chain_Packaging. Details
0 .. 1	CI_Supply Chain_Packaging. Type. Code Business Requirement 13/07/2008 CSC PAC0002 0..1 Packaging Type Code
0 .. 1	CI_Supply Chain_Packaging. Type. Text Business Requirement 13/07/2008 CSC PAC0001 0..1 Packaging Type Description
0 .. 1	CI_Supply Chain_Packaging. Condition. Code Business Requirement 13/07/2008 CSC PAC0003 0..1 Packaging Condition
0 .. unbounded	CI_Supply Chain_Packaging. Disposal Method. Code Business Requirement 13/07/2008 CSC PAC0016 0..1 Destructible Indicator
0 .. unbounded	CI_Supply Chain_Packaging. Weight. Measure Business Requirement 13/07/2008 CSC PAC0005 0..1 Packaging weight
0 .. 1	CI_Supply Chain_Packaging. Maximum Stackability. Quantity
0 .. 1	CI_Supply Chain_Packaging. Maximum Stackability_ Weight. Measure
0 .. unbounded	CI_Supply Chain_Packaging. Description. Text
0 .. 1	CI_Supply Chain_Packaging. Customer Facing_ Total Unit. Quantity
0 .. 1	CI_Supply Chain_Packaging. Layer_ Total Unit. Quantity
0 .. 1	CI_Supply Chain_Packaging. Linear. CI_Spatial_Dimension
	Main::CI_Spatial_Dimension. Details Business Requirement 13/07/2008 CSC PAC0011 0..1 Packaging Nominal Dimension
0 .. 1	CI_Supply Chain_Packaging. Minimum_Linear. CI_Spatial_Dimension
	Main::CI_Spatial_Dimension. Details Business Requirement 13/07/2008 CSC PAC0012 0..1 Packaging Minimum Dimension
0 .. 1	CI_Supply Chain_Packaging. Maximum_Linear. CI_Spatial_Dimension
	Main::CI_Spatial_Dimension. Details Business Requirement 13/07/2008 CSC PAC0013 0..1 Packaging Maximum Dimension
0 .. unbounded	CI_Supply Chain_Packaging. Specified. CI_Packaging_Marking
	Main::CI_Packaging_Marking. Details Business Requirement 13/07/2008 CSC PAC0009 0..* Packaging Marks

Occurrence	Element/Attribute
	CI_Supply Chain_Supply Plan. Details
0 .. 1	CI_Supply Chain_Supply Plan. Commitment Level. Code Business Requirement 08/11/2008 CSC SPL0007 0..1 Commitment level code
0 .. 1	CI_Supply Chain_Supply Plan. Planned. Quantity Business Requirement 08/11/2008 CSC SPL0008 0..1 Planned quantity
0 .. 1	CI_Supply Chain_Supply Plan. Actual. Quantity Business Requirement 08/11/2008 CSC SPL0006 0..1 Actual Quantity
0 .. 1	CI_Supply Chain_Supply Plan. Tolerance. Quantity Business Requirement 08/11/2008 CSC SPL0011 0..1 Tolerance quantity
0 .. 1	CI_Supply Chain_Supply Plan. Minus_Tolerance. Quantity
0 .. 1	CI_Supply Chain_Supply Plan. Plus_Tolerance. Quantity
0 .. 1	CI_Supply Chain_Supply Plan. Specified. CI_Specified_Period Main::CI_Specified_Period. Details Business Requirement 08/11/2008 CSC SPL0002 0..1 Period
0 .. unbounded	CI_Supply Chain_Supply Plan. Delivery. CI_Supply Chain_Event Main::CI_Supply Chain_Event. Details Business Requirement 08/11/2008 CSC SPL0012 0..1 Delivery Event
0 .. unbounded	CI_Supply Chain_Supply Plan. Specified. CI_Logistics_Location Main::CI_Logistics_Location. Details Business Requirement 08/11/2008 CSC SPL0001 0..1 Location
0 .. unbounded	CI_Supply Chain_Supply Plan. Contract_Referenced. CI_Referenced_Document Main::CI_Referenced_Document. Details Business Requirement 08/11/2008 CSC SPL0005 0..1 Contract Reference
0 .. unbounded	CI_Supply Chain_Supply Plan. Scheduled_Delivery. CI_Supply Chain_Event Main::CI_Supply Chain_Event. Details
0 .. unbounded	CI_Supply Chain_Supply Plan. Confirmed_Delivery. CI_Supply Chain_Event Main::CI_Supply Chain_Event. Details
0 .. unbounded	CI_Supply Chain_Supply Plan. Delivery Note_Referenced. CI_Referenced_Document Main::CI_Referenced_Document. Details
0 .. 1	CI_Supply Chain_Supply Plan. Ship To. CI_Trade_Party Main::CI_Trade_Party. Details

Occurrence	Element/Attribute
	CI_Tax_Registration. Details
0 .. 1	CI_Tax_Registration. Identification. Identifier
0 .. 1	CI_Tax_Registration. Associated. CI_Registered_Tax
	Main::CI_Registered_Tax. Details

Occurrence	Element/Attribute
CI_Trade Settlement_Payment Means. Details	
0 .. 1	CI_Trade Settlement_Payment Means. Payment Channel. Code Business Requirement 13/07/2008 CSC PYM0004 0..1 Payment Channel Code
0 .. 1	CI_Trade Settlement_Payment Means. Type. Code Business Requirement 13/07/2008 CSC PYM0003 0..1 Payment Means Type Code - is this correct mapping? If so, how to map PYM005?
0 .. 1	CI_Trade Settlement_Payment Means. Guarantee Method. Code Business Requirement 13/07/2008 CSC PYM0002 0..1 Payment Guarantee Code
0 .. 1	CI_Trade Settlement_Payment Means. Payment Method. Code Business Requirement 13/07/2008 CSC PYM0001 0..1 Payment Method Code
0 .. unbounded	CI_Trade Settlement_Payment Means. Identification. Identifier Business Requirement 16/05/2009 CSC PYM0012 0.* ID
0 .. 1	CI_Trade Settlement_Payment Means. Payer_Party. CI_Debtor_Financial Account Main::CI_Debtor_Financial Account. Details Business Requirement 13/07/2008 CSC PYM0008 0..1 Payer Financial Account
0 .. 1	CI_Trade Settlement_Payment Means. Payee_Party. CI_Creditor_Financial Account Main::CI_Creditor_Financial Account. Details Business Requirement 13/07/2008 CSC PYM0009 0..1 Payee Financial Account
0 .. 1	CI_Trade Settlement_Payment Means. Payer_Specified. CI_Debtor_Financial Institution Main::CI_Debtor_Financial Institution. Details Business Requirement 08/11/2008 CSC PYM0010 0..1 Payer Financial Institution
0 .. 1	CI_Trade Settlement_Payment Means. Payee_Specified. CI_Creditor_Financial Institution Main::CI_Creditor_Financial Institution. Details Business Requirement 08/11/2008 CSC PYM0011 0..1 Payee Financial Institution
0 .. 1	CI_Trade Settlement_Payment Means. Applicable. Trade Settlement_Financial Card Main::Trade Settlement_Financial Card. Details

Occurrence	Element/Attribute
CI_Trade_Accounting Account. Details	
1 .. 1	<ul style="list-style-type: none"> — <i>CI_Trade_Accounting Account. Identification. Identifier</i> <ul style="list-style-type: none"> Business Requirement 12/07/2008 CSC ACC0001 1..1 Account Identification - is this requirement
0 .. 1	<ul style="list-style-type: none"> — <i>CI_Trade_Accounting Account. Set Trigger. Code</i> <ul style="list-style-type: none"> Business Requirement 12/07/2008 CSC ACC0002 0..1 Account Set Trigger
0 .. 1	<ul style="list-style-type: none"> — <i>CI_Trade_Accounting Account. Type. Code</i> <ul style="list-style-type: none"> Business Requirement 12/07/2008 CSC ACC0003 0..1 Account Type
0 .. 1	<ul style="list-style-type: none"> — <i>CI_Trade_Accounting Account. Amount Type. Code</i> <ul style="list-style-type: none"> Business Requirement 12/07/2008 CSC ACC0004 0..1 Account Amount Identification
0 .. 1	<ul style="list-style-type: none"> — <i>CI_Trade_Accounting Account. Name. Text</i> <ul style="list-style-type: none"> Business Requirement 12/07/2008 CSC ACC0006 0..1 Name
0 .. 1	<ul style="list-style-type: none"> — <i>CI_Trade_Accounting Account. Cost Reference Dimension Pattern. Text</i> <ul style="list-style-type: none"> Business Requirement 08/09/2008 CSC ACC0005 0..1 Cost Assignment Reference

Occurrence	Element/Attribute
	CI_Trade_Address_Details
0 .. 1	CI_Trade_Address. Identification. Identifier Business Requirement 12/07/2008 CSC ADR0001 0..1 Address Identification
0 .. 1	CI_Trade_Address. Postcode. Code Business Requirement 12/07/2008 CSC ADR0007 0..1 Postcode
0 .. 1	CI_Trade_Address. Post Office Box. Text Business Requirement 12/07/2008 CSC ADR0002 0..1 Post Office Box
0 .. 1	CI_Trade_Address. Building Name. Text Business Requirement 12/07/2008 CSC ADR0004 0..1 Building name
0 .. 1	CI_Trade_Address. Line One. Text Business Requirement 12/07/2008 CSC ADR0008 0..1 Address line one
0 .. 1	CI_Trade_Address. Line Two. Text Business Requirement 12/07/2008 CSC ADR0009 0..1 Address line two
0 .. 1	CI_Trade_Address. Line Three. Text Business Requirement 12/07/2008 CSC ADR0010 0..1 Address line three
0 .. 1	CI_Trade_Address. Line Four. Text Business Requirement 12/07/2008 CSC ADR0011 0..1 Address line four
0 .. 1	CI_Trade_Address. Line Five. Text Business Requirement 12/07/2008 CSC ADR0012 0..1 Address line five
0 .. 1	CI_Trade_Address. Street Name. Text Business Requirement 12/07/2008 CSC ADR0003 0..1 Street name
0 .. 1	CI_Trade_Address. City Name. Text Business Requirement 12/07/2008 CSC ADR0005 0..1 City name
0 .. 1	CI_Trade_Address. City Sub-Division Name. Text Business Requirement 12/07/2008 CSC ADR0006 0..1 City Sub Division name
0 .. 1	CI_Trade_Address. Country. Identifier Business Requirement 12/07/2008 CSC ADR0013 0..1 Country Identification
0 .. unbounded	CI_Trade_Address. Country Name. Text Business Requirement 12/07/2008 CSC ADR0014 0..1 Country name
0 .. 1	CI_Trade_Address. Country Sub-Division. Identifier Business Requirement 12/07/2008 CSC ADR0015 0..1 Country Sub-Division identification
0 .. unbounded	CI_Trade_Address. Country Sub-Division Name. Text Business Requirement 12/07/2008 CSC ADR0016 0..1 Country Sub-Division name
0 .. 1	CI_Trade_Address. Attention Of. Text Business Requirement 13/07/2008 CSC PAR0006 0..1 Party Attention Of Indicator
0 .. 1	CI_Trade_Address. Care Of. Text Business Requirement 13/07/2008 CSC PAR0005 0..1 Party Mark Care Of Indicator
0 .. 1	CI_Trade_Address. Building Number. Text Business Requirement 12/07/2008 CSC ADR0017 0..1 Building Number

Occurrence	Element/Attribute
CI_Trade_Allowance Charge. Details	
0 .. 1	CI_Trade_Allowance Charge. Charge. Indicator Business Requirement 12/07/2008 CSC ALC0003 0..1 Charge indicator
0 .. 1	CI_Trade_Allowance Charge. Identification. Identifier Business Requirement 12/07/2008 CSC ALC0001 0..1 Allowance charge identification
0 .. 1	CI_Trade_Allowance Charge. Sequence. Numeric Business Requirement 12/07/2008 CSC ALC0006 0..1 Calculation sequence number
0 .. 1	CI_Trade_Allowance Charge. Calculation. Percent Business Requirement 12/07/2008 CSC ALC0005 0..1 Allowance charge percent
0 .. 1	CI_Trade_Allowance Charge. Basis. Quantity Business Requirement 12/07/2008 CSC ALC0002 0..1 Allowance charge base quantity
0 .. 1	CI_Trade_Allowance Charge. Prepaid. Indicator Business Requirement 12/07/2008 CSC ALC0004 0..1 Prepaid charge levy indicator
0 .. unbounded	CI_Trade_Allowance Charge. Actual. Amount Business Requirement 12/07/2008 CSC ALC0007 0..1 Allowance charge amount
0 .. 1	CI_Trade_Allowance Charge. Reason. Code Business Requirement 12/07/2008 CSC ALC0008 0..1 Allowance charge reason code
0 .. 1	CI_Trade_Allowance Charge. Reason. Text Business Requirement 12/07/2008 CSC ALC0009 0..1 Allowance charge reason text
0 .. unbounded	CI_Trade_Allowance Charge. Category. CI_Trade_Tax Main::CI_Trade_Tax. Details Business Requirement 12/07/2008 CSC ALC0011 0..1 Tax category
0 .. 1	CI_Trade_Allowance Charge. Actual. CI_Trade_Currency Exchange Main::CI_Trade_Currency Exchange. Details Business Requirement 12/07/2008 CSC ALC0010 0..1 Allowance charge currency exchange

Occurrence	Element/Attribute
	CI_Trade_Contact_Details
0 .. 1	CI_Trade_Contact_Identifier Business Requirement 12/07/2008 CSC CON0001 0..1 Contact identification
0 .. 1	CI_Trade_Contact_PersonName_Text Business Requirement 12/07/2008 CSC CON0006 0..1 Contact person name
0 .. 1	CI_Trade_Contact_DepartmentName_Text Business Requirement 12/07/2008 CSC CON0004 0..1 Contact department name
0 .. 1	CI_Trade_Contact_Type_Code Business Requirement 12/07/2008 CSC CON0007 0..1 Contact type code
0 .. 1	CI_Trade_Contact_JobTitle_Text Business Requirement 12/07/2008 CSC CON0002 0..1 Contact job title
0 .. 1	CI_Trade_Contact_Responsibility_Text Business Requirement 12/07/2008 CSC CON0003 0..1 Contact responsibility
0 .. unbounded	CI_Trade_Contact_Person_Identifier_Identifier Business Requirement 12/07/2008 CSC CON0005 0..1 Contact person identifier
0 .. 1	CI_Trade_Contact_Telephone_CI_Universal_Communication Main::CI_Universal_Communication_Details Business Requirement 12/07/2008 CSC COM0001 0..1 Identification Identifier mapping
0 .. 1	CI_Trade_Contact_Direct_Telephone_CI_Universal_Communication Main::CI_Universal_Communication_Details Business Requirement 12/07/2008 CSC CON0010 0..1 Direct telephone number
0 .. 1	CI_Trade_Contact_Mobile_Telephone_CI_Universal_Communication Main::CI_Universal_Communication_Details Business Requirement 12/07/2008 CSC CON0011 0..1 Mobile telephone number
0 .. 1	CI_Trade_Contact_Fax_CI_Universal_Communication Main::CI_Universal_Communication_Details Business Requirement 12/07/2008 CSC CON0012 0..1 Fax number
0 .. 1	CI_Trade_Contact_Email_URI_CI_Universal_Communication Main::CI_Universal_Communication_Details Business Requirement 12/07/2008 CSC CON0014 0..1 E-mail address
0 .. 1	CI_Trade_Contact_Telex_CI_Universal_Communication Main::CI_Universal_Communication_Details Business Requirement 12/07/2008 CSC CON0013 0..1 Telex number
0 .. 1	CI_Trade_Contact_VOIP_CI_Universal_Communication Main::CI_Universal_Communication_Details Business Requirement 12/07/2008 CSC CON0015 0..1 Other communication (VOIP)
0 .. 1	CI_Trade_Contact_Instant_Messaging_CI_Universal_Communication Main::CI_Universal_Communication_Details Business Requirement 12/07/2008 CSC CON0015 0..1 Other communication (Instant
0 .. unbounded	CI_Trade_Contact_Specified_CI_Note Main::CI_Note_Details Business Requirement 12/07/2008 CSC CON0008 0..* Note

Occurrence	Element/Attribute
	CI_Trade_Country Sub-Division. Details
0 .. 1	CI_Trade_Country Sub-Division. Identification. Identifier
0 .. unbounded	CI_Trade_Country Sub-Division. Name. Text

Occurrence	Element/Attribute
	CI_Trade_Country. Details
0 .. 1	CI_Trade_Country. Identification. Identifier
0 .. unbounded	CI_Trade_Country. Name. Text
0 .. unbounded	CI_Trade_Country. Subordinate. CI_Trade_Country Sub-Division
	Main::CI_Trade_Country Sub-Division. Details

Occurrence	Element/Attribute
	CI_Trade_Currency Exchange. Details
1 .. 1	<ul style="list-style-type: none"> — <i>CI_Trade_Currency Exchange. Source Currency. Code</i> Business Requirement 12/07/2008 CSC CUX0001 1..1 Source currency
0 .. 1	<ul style="list-style-type: none"> — <i>CI_Trade_Currency Exchange. Source Unit Basis. Numeric</i> Business Requirement 12/07/2008 CSC CUX0002 0..1 Unit base source currency
1 .. 1	<ul style="list-style-type: none"> — <i>CI_Trade_Currency Exchange. Target Currency. Code</i> Business Requirement 12/07/2008 CSC CUX0003 1..1 Target currency
0 .. 1	<ul style="list-style-type: none"> — <i>CI_Trade_Currency Exchange. Target Unit Base. Numeric</i> Business Requirement 12/07/2008 CSC CUX0004 0..1 Unit base target currency
0 .. 1	<ul style="list-style-type: none"> — <i>CI_Trade_Currency Exchange. Market. Identifier</i> Business Requirement 12/07/2008 CSC CUX0007 0..1 Exchange Market ID
1 .. 1	<ul style="list-style-type: none"> — <i>CI_Trade_Currency Exchange. Conversion. Rate</i> Business Requirement 12/07/2008 CSC CUX0005 1..1 Exchange rate
0 .. 1	<ul style="list-style-type: none"> — <i>CI_Trade_Currency Exchange. Conversion Rate. Date Time</i> Business Requirement 12/07/2008 CSC CUX0006 0..1 Exchange date time
0 .. 1	<ul style="list-style-type: none"> — CI_Trade_Currency Exchange. Referenced. CI_Referenced_Document Main::CI_Referenced_Document. Details Business Requirement 12/07/2008 CSC CUX0008 0..1 Foreign Exchange Contract - maybe PT should be qualified with Contract or Foreign Exchange Contract?

Occurrence	Element/Attribute
	CI_Trade_Delivery Terms. Details
0 .. 1	<ul style="list-style-type: none"> CI_Trade_Delivery Terms. Delivery Type. Code <ul style="list-style-type: none"> Business Requirement 12/07/2008 CSC DEL0001 0..1 Delivery terms code
0 .. unbounded	<ul style="list-style-type: none"> CI_Trade_Delivery Terms. Description. Text <ul style="list-style-type: none"> Business Requirement 12/07/2008 CSC DEL0002 0..1 Delivery terms
0 .. 1	<ul style="list-style-type: none"> CI_Trade_Delivery Terms. Relevant. CI_Trade_Location <ul style="list-style-type: none"> Main::CI_Trade_Location. Details Business Requirement 12/07/2008 CSC DEL0003 0..1 Location

Occurrence	Element/Attribute
------------	-------------------

CI_Trade_Location. Details

0 .. 1	<ul style="list-style-type: none"> — <i>CI_Trade_Location. Country. Identifier</i> <ul style="list-style-type: none"> Business Requirement 13/07/2008 CSC DEL0004 0..1 Delivery Terms Country Identifier
0 .. 1	<ul style="list-style-type: none"> — <i>CI_Trade_Location. Country Name. Text</i> <ul style="list-style-type: none"> Business Requirement 13/07/2008 CSC DEL0005 0..1 Delivery Terms Country Name
0 .. 1	<ul style="list-style-type: none"> — <i>CI_Trade_Location. Identification. Identifier</i> <ul style="list-style-type: none"> Business Requirement 13/07/2008 CSC DEL0008 0..1 Trade Location Name
0 .. 1	<ul style="list-style-type: none"> — <i>CI_Trade_Location. Name. Text</i> <ul style="list-style-type: none"> Business Requirement 13/07/2008 CSC DEL0007 0..1 Trade Location Name

Occurrence	Element/Attribute
	CI_Trade_Party_Details
0 .. unbounded	CI_Trade_Party_Identification_Identifier Business Requirement 13/07/2008 CSC PAR0001 1..1 Party Identification
0 .. unbounded	CI_Trade_Party_Global_Identifier_Identifier Business Requirement 13/07/2008 CSC PAR0002 0..* Party additional identification
0 .. 1	CI_Trade_Party_Name_Text Business Requirement 13/07/2008 CSC PAR0004 0..1 Party Name
0 .. unbounded	CI_Trade_Party_Role_Code
0 .. 1	CI_Trade_Party_Specified_CI_Legal_Organization Main::CI_Legal_Organization_Details Business Requirement 13/07/2008 CSC PAR0010 0..1 Party Legal Entity
0 .. unbounded	CI_Trade_Party_Defined_CI_Trade_Contact Main::CI_Trade_Contact_Details Business Requirement 13/07/2008 CSC PAR0016 0..1 Party Contract Contact 13/07/2008 CSC PAR0017 0..1 Party Technical Contact 13/07/2008 CSC PAR0018 0..1 Party New Development Contact 13/07/2008 CSC PAR0019 0..1 Party Order Processing Contact 13/07/2008 CSC PAR0020 0..1 Party Customer Relations Contact 13/07/2008 CSC PAR0021 0..1 Party Delivery Contact 13/07/2008 CSC PAR0022 0..1 Party Goods Receiving Contact 13/07/2008 CSC PAR0023 0..1 Party Material Control Contact 13/07/2008 CSC PAR0024 0..1 Party Information Contact 13/07/2008 CSC PAR0025 0..1 Party Order Contact 13/07/2008 CSC PAR0026 0..1 Party Sales Administration Contact 13/07/2008 CSC PAR0027 0..1 Party Supplier Contact 13/07/2008 CSC PAR0028 0..1 Party Technical Documentation 13/07/2008 CSC PAR0029 0..1 Party Accounting Contact
0 .. 1	CI_Trade_Party_Postal_CI_Trade_Address Main::CI_Trade_Address_Details Business Requirement 13/07/2008 CSC PAR0030 0..1 Party Postal Address
0 .. unbounded	CI_Trade_Party_URI_CI_Universal_Communication Main::CI_Universal_Communication_Details Business Requirement 13/07/2008 CSC PAR0008 0..1 Party web-site_Uniform Resource Identification
0 .. unbounded	CI_Trade_Party_Specified_CI_Tax_Registration Main::CI_Tax_Registration_Details Business Requirement 08/11/2008 CSC PAR0003 0..* Party tax Identification
0 .. 1	CI_Trade_Party_End_Point_URI_CI_Universal_Communication Main::CI_Universal_Communication_Details Business Requirement 13/07/2008 CSC PAR0007 0..1 Party End Point Identifier
0 .. unbounded	CI_Trade_Party_Logo_Associated_Specified_Binary_File Main::Specified_Binary_File_Details

Occurrence	Element/Attribute
------------	-------------------

CI_Trade_Payment Discount Terms. Details

0 .. 1	CI_Trade_Payment Discount Terms. Basis. Date Time
0 .. 1	CI_Trade_Payment Discount Terms. Basis Period. Measure
	Business Requirement
	13/07/2008 CSC PYT0008 0..1 Payment Discount Period
0 .. 1	CI_Trade_Payment Discount Terms. Basis. Amount
0 .. 1	CI_Trade_Payment Discount Terms. Calculation. Percent
	Business Requirement
	13/07/2008 CSC PYT0007 0..1 Payment Discount Percent
0 .. 1	CI_Trade_Payment Discount Terms. Actual Discount. Amount
	Business Requirement
	08/11/2008 CSC PYT0015 0..1 Payment Discount amount

Occurrence	Element/Attribute
	CI_Trade_Payment Penalty Terms. Details
0 .. 1	CI_Trade_Payment Penalty Terms. Basis. Date Time
0 .. 1	CI_Trade_Payment Penalty Terms. Basis Period. Measure
	Business Requirement
	13/07/2008 CSC PYT0010 0..1 Penalty Period
0 .. 1	CI_Trade_Payment Penalty Terms. Basis. Amount
0 .. 1	CI_Trade_Payment Penalty Terms. Calculation. Percent
	Business Requirement
	13/07/2008 CSC PYT0009 0..1 Penalty Surcharge Percent
0 .. 1	CI_Trade_Payment Penalty Terms. Actual Penalty. Amount
	Business Requirement
	08/11/2008 CSC PYT0016 0..1 Payment terms penalty amount

Occurrence	Element/Attribute
	CI_Trade_Payment Terms. Details
0 .. 1	CI_Trade_Payment Terms. Identification. Identifier Business Requirement 13/07/2008 CSC PYT0001 0..1 Payment Terms Identification
0 .. 1	CI_Trade_Payment Terms. From Event. Code Business Requirement 13/07/2008 CSC PYT0002 0..1 Payment Terms time reference
0 .. 1	CI_Trade_Payment Terms. Settlement Period. Measure Business Requirement 13/07/2008 CSC PYT0003 0..1 Payment Terms number of periods
0 .. unbounded	CI_Trade_Payment Terms. Description. Text Business Requirement 13/07/2008 CSC PYT0004 0..* Payment Terms Note - Workbase is only
0 .. 1	CI_Trade_Payment Terms. Due Date. Date Time Business Requirement 13/07/2008 CSC PYT0005 1..1 Payment Terms Due Date
0 .. 1	CI_Trade_Payment Terms. Instruction_ Type. Code Business Requirement 13/07/2008 CSC PYT0006 0..1 Payment Terms Instruction ID
0 .. unbounded	CI_Trade_Payment Terms. Payment Means_ Identification. Identifier Business Requirement 13/07/2008 CSC PYT0018 0..* Payment Means ID
0 .. 1	CI_Trade_Payment Terms. Partial Payment. Percent Business Requirement 13/07/2008 CSC PYT0017 0..1 Payment Terms Percentage
0 .. unbounded	CI_Trade_Payment Terms. Direct Debit Mandate_ Identification. Identifier
0 .. 1	CI_Trade_Payment Terms. Applicable. CI_Trade_Payment Penalty Terms Main::CI_Trade_Payment Penalty Terms. Details Business Requirement 13/07/2008 CSC PYT008a? 0..1 Mapping to Trade_Payment Penalty
0 .. 1	CI_Trade_Payment Terms. Applicable. CI_Trade_Payment Discount Terms Main::CI_Trade_Payment Discount Terms. Details Business Requirement 13/07/2008 CSC PYT006a? 0..1 Mapping to Trade_Payment Discount Terms missing in BRS

Occurrence	Element/Attribute
	CI_Trade_Price_Details
0 .. 1	<ul style="list-style-type: none"> CI_Trade_Price_Type_Code <ul style="list-style-type: none"> Business Requirement 13/07/2008 CSC PRI0002 0..1 Price type code
1 .. unbounded	<ul style="list-style-type: none"> CI_Trade_Price_Charge_Amount <ul style="list-style-type: none"> Business Requirement 13/07/2008 CSC PRI0003 1..1 Price amount
0 .. 1	<ul style="list-style-type: none"> CI_Trade_Price_Basis_Quantity <ul style="list-style-type: none"> Business Requirement 13/07/2008 CSC PRI0004 0..1 Price base quantity
0 .. 1	<ul style="list-style-type: none"> CI_Trade_Price_Order_Unit_Conversion_Factor_Numeric <ul style="list-style-type: none"> Business Requirement 13/07/2008 CSC PRI0009 0..1 Orderable unit factor rate
0 .. unbounded	<ul style="list-style-type: none"> CI_Trade_Price_Change_Reason_Text
0 .. 1	<ul style="list-style-type: none"> CI_Trade_Price_Minimum_Quantity
0 .. 1	<ul style="list-style-type: none"> CI_Trade_Price_Maximum_Quantity
0 .. unbounded	<ul style="list-style-type: none"> CI_Trade_Price_Applied_CI_Trade_Allowance_Charge <ul style="list-style-type: none"> Main::CI_Trade_Allowance_Charge_Details Business Requirement 13/07/2008 CSC PRI0005 0.* Price allowance charge
0 .. 1	<ul style="list-style-type: none"> CI_Trade_Price_Validity_CI_Specified_Period <ul style="list-style-type: none"> Main::CI_Specified_Period_Details Business Requirement 13/07/2008 CSC PRI0006 0..1 Validity period
0 .. unbounded	<ul style="list-style-type: none"> CI_Trade_Price_Referenced_CI_Referenced_Document <ul style="list-style-type: none"> Main::CI_Referenced_Document_Details Business Requirement 13/07/2008 CSC PRI0008 0..1 Pricing Reference Document
0 .. unbounded	<ul style="list-style-type: none"> CI_Trade_Price_Delivery_CI_Trade_Location <ul style="list-style-type: none"> Main::CI_Trade_Location_Details
0 .. unbounded	<ul style="list-style-type: none"> CI_Trade_Price_Trade_Comparison_Reference_Price <ul style="list-style-type: none"> Main::Reference_Price_Details

Occurrence	Element/Attribute
CI_Trade_Product Instance. Details	
0 .. 1	<i>CI_Trade_Product Instance. Global Serial_ Identification. Identifier</i> Business Requirement 13/07/2008 CSC PIN0004 0..* Serial number - D08B cardinality is
0 .. 1	<i>CI_Trade_Product Instance. Batch_ Identification. Identifier</i> Business Requirement 13/07/2008 CSC PIN0002 0..1 Batch number
0 .. 1	<i>CI_Trade_Product Instance. Kanban_ Identification. Identifier</i> Business Requirement 13/07/2008 CSC PIN0005 0..1 Kanban number
0 .. 1	<i>CI_Trade_Product Instance. Supplier Assigned Serial_ Identification. Identifier</i> Business Requirement 13/07/2008 CSC PIN0001 0..1 Supplier item identification
0 .. 1	<i>CI_Trade_Product Instance. Best Before. Date Time</i> Business Requirement 13/07/2008 CSC PIN0007 0..1 Best before date time
0 .. 1	<i>CI_Trade_Product Instance. Expiry. Date Time</i> Business Requirement 13/07/2008 CSC PIN0008 0..1 Expiration date time
0 .. 1	<i>CI_Trade_Product Instance. Sell By. Date Time</i> Business Requirement 13/07/2008 CSC PIN0010 0..1 Sell by date
0 .. unbounded	<i>CI_Trade_Product Instance. Serial_ Identification. Identifier</i>
0 .. unbounded	<i>CI_Trade_Product Instance. Registration_ Identification. Identifier</i>
0 .. unbounded	CI_Trade_Product Instance. Product. CI_Product_Characteristic Main::CI_Product_Characteristic. Details Business Requirement 13/07/2008 CSC PIN0011 0..* Characteristic
0 .. 1	CI_Trade_Product Instance. Production. CI_Supply Chain_Event Main::CI_Supply Chain_Event. Details
0 .. 1	CI_Trade_Product Instance. Packaging. CI_Supply Chain_Event Main::CI_Supply Chain_Event. Details
0 .. unbounded	CI_Trade_Product Instance. Applicable. CI_Material_Goods Characteristic Main::CI_Material_Goods Characteristic. Details

Occurrence	Element/Attribute
	CI_Trade_Product. Details
0 .. 1	CI_Trade_Product. Identification. Identifier
0 .. 1	CI_Trade_Product. Global_ Identification. Identifier
0 .. 1	CI_Trade_Product. Seller Assigned_ Identification. Identifier
	Business Requirement
	13/07/2008 CSC PRO0001 0..1 Supplier item identifier - PRO0006
0 .. 1	CI_Trade_Product. Buyer Assigned_ Identification. Identifier
	Business Requirement
	13/07/2008 CSC PRO0005 0..1 Customer article number
0 .. 1	CI_Trade_Product. Manufacturer Assigned_ Identification. Identifier
	Business Requirement
	13/07/2008 CSC PRO0002 0..1 Manufacturer item identifier -
0 .. unbounded	CI_Trade_Product. Name. Text
	Business Requirement
	13/07/2008 CSC PRO0009 0..1 Article Name
0 .. 1	CI_Trade_Product. Trade_ Name. Text
	Business Requirement
	13/07/2008 CSC PRO0010 0..1 Trade Name
0 .. 1	CI_Trade_Product. Description. Text
	Business Requirement
	13/07/2008 CSC PRO0008 0..1 Article Description
0 .. 1	CI_Trade_Product. Type. Code
0 .. 1	CI_Trade_Product. Net Weight. Measure
	Business Requirement
	13/07/2008 CSC PRO0015 0..1 Trade Weight_Net
0 .. 1	CI_Trade_Product. Gross Weight. Measure
	Business Requirement
	13/07/2008 CSC PRO0015 0..1 Trade Weight _ Gross
0 .. 1	CI_Trade_Product. Drained_ Net Weight. Measure
0 .. 1	CI_Trade_Product. Brand_ Name. Text
0 .. 1	CI_Trade_Product. Sub-Brand_ Name. Text
0 .. unbounded	CI_Trade_Product. Applicable. Product_ Characteristic
	Main::Product_ Characteristic. Details
	Business Requirement
	13/07/2008 CSC PRO0011 0..* Characteristic
0 .. unbounded	CI_Trade_Product. Applicable. CI_Material_Goods Characteristic
	Main::CI_Material_Goods Characteristic. Details
	Business Requirement
	13/07/2008 CSC PRO0012 0..* Material
0 .. unbounded	CI_Trade_Product. Designated. CI_Product_Classification
	Main::CI_Product_Classification. Details
	Business Requirement
	13/07/2008 CSC PRO0013 0..* Product Classification
0 .. unbounded	CI_Trade_Product. Individual. CI_Trade_Product Instance
	Main::CI_Trade_Product Instance. Details
	Business Requirement
	13/07/2008 CSC PRO0014 0..* Product Instance
0 .. unbounded	CI_Trade_Product. Certification Evidence_ Reference. CI_Referenced_ Document
	Main::CI_Referenced_ Document. Details
	Business Requirement
	13/07/2008 CSC PRO0017 0..* Certificate
0 .. unbounded	CI_Trade_Product. Inspection_ Reference. CI_Referenced_ Document
	Main::CI_Referenced_ Document. Details
	Business Requirement
	13/07/2008 CSC PRO0018 0..* Inspection document
0 .. 1	CI_Trade_Product. Origin. CI_Trade_Country
	Main::CI_Trade_Country. Details

Occurrence	Element/Attribute
	Business Requirement 08/11/2008 CSC PRO0003 0..1 Origin Country Code
0 .. 1	CI_Trade_Product.Linear_CI_Spatial_Dimension Main::CI_Spatial_Dimension.Details
	Business Requirement 13/07/2008 CSC PRO0022 0..1 Nominal dimension
0 .. 1	CI_Trade_Product.Minimum_Linear_CI_Spatial_Dimension Main::CI_Spatial_Dimension.Details
	Business Requirement 13/07/2008 CSC PRO0023 0..1 Minimum dimension
0 .. 1	CI_Trade_Product.Maximum_Linear_CI_Spatial_Dimension Main::CI_Spatial_Dimension.Details
	Business Requirement 13/07/2008 CSC PRO0024 0..1 Maximum dimension
0 .. 1	CI_Trade_Product.Manufacturer_CI_Trade_Party Main::CI_Trade_Party.Details
	Business Requirement 13/07/2008 CSC PRO0016 0..1 Manufacturer
0 .. 1	CI_Trade_Product.MSDS_Reference_CI_Referenced_Document Main::CI_Referenced_Document.Details
0 .. unbounded	CI_Trade_Product.Additional_Reference_CI_Referenced_Document Main::CI_Referenced_Document.Details
0 .. unbounded	CI_Trade_Product.Information_CI_Note Main::CI_Note.Details

Occurrence	Element/Attribute
	CI_Trade_Tax_Details
0 .. unbounded	<ul style="list-style-type: none"> — <i>CI_Trade_Tax.Calculated.Amount</i> Business Requirement 13/07/2008 CSC TAX0002 0..1 Taxable amount - TAX006 is a duplicate in
0 .. 1	<ul style="list-style-type: none"> — <i>CI_Trade_Tax.Type.Code</i> Business Requirement 13/07/2008 CSC TXS0001 0..1 Tax fee type
0 .. 1	<ul style="list-style-type: none"> — <i>CI_Trade_Tax.Exemption.Reason.Text</i> Business Requirement 13/07/2008 CSC TAX0011 0..1 Tax fee exemption reason text
0 .. 1	<ul style="list-style-type: none"> — <i>CI_Trade_Tax.Calculated.Rate</i> Business Requirement 13/07/2008 CSC TAX0020 0..1 Ta Fee Category Rate
0 .. 1	<ul style="list-style-type: none"> — <i>CI_Trade_Tax.Calculation.Sequence.Numeric</i> Business Requirement 13/07/2008 CSC TAX0010 0..1 Calculation sequence number
0 .. 1	<ul style="list-style-type: none"> — <i>CI_Trade_Tax.Basis.Quantity</i> Business Requirement 13/07/2008 CSC TAX0014 0..1 Base unit measure - should a new BBIE qualified by Unit be added to Trade Tax for
0 .. unbounded	<ul style="list-style-type: none"> — <i>CI_Trade_Tax.Basis.Amount</i> Business Requirement 13/07/2008 CSC TAX0001 0..1 Taxable amount - TAX005 is a duplicate in
0 .. unbounded	<ul style="list-style-type: none"> — <i>CI_Trade_Tax.Unit.Basis.Amount</i> Business Requirement 13/07/2008 CSC TAX0015 0..1 Per unit amount
0 .. 1	<ul style="list-style-type: none"> — <i>CI_Trade_Tax.Category.Code</i> Business Requirement 13/07/2008 CSC TAX0018 0..1 Tax category code
0 .. 1	<ul style="list-style-type: none"> — <i>CI_Trade_Tax.Currency.Code</i> Business Requirement 13/07/2008 CSC TXS0004 0..1 Currency code
0 .. unbounded	<ul style="list-style-type: none"> — <i>CI_Trade_Tax.Jurisdiction.Text</i> Business Requirement 13/07/2008 CSC TXS0002 0..1 Tax fee jurisdiction text
0 .. 1	<ul style="list-style-type: none"> — <i>CI_Trade_Tax.Customs.Duty.Indicator</i> Business Requirement 13/07/2008 CSC TXS0005 0..1 Tax Fee indicator - is this mapped correctly, maybe new BCC/BBIE
0 .. 1	<ul style="list-style-type: none"> — <i>CI_Trade_Tax.Exemption.Reason.Code</i> Business Requirement 13/07/2008 CSC TAX0012 0..1 Tax fee exemption reason code
0 .. 1	<ul style="list-style-type: none"> — <i>CI_Trade_Tax.Tax.Basis.Allowance.Rate</i> Business Requirement 13/07/2008 CSC TAX0016 0..1 Taxable amount allowance rate
0 .. 1	<ul style="list-style-type: none"> — <i>CI_Trade_Tax.Tax.Point.Date</i> Business Requirement 13/07/2008 CSC TAX0021 0..1 Tax Point Date
0 .. 1	<ul style="list-style-type: none"> — <i>CI_Trade_Tax.Type.Text</i> Business Requirement 13/07/2008 CSC TXS0003 0..1 Tax fee name
0 .. unbounded	<ul style="list-style-type: none"> — <i>CI_Trade_Tax.Information.Amount</i>
0 .. unbounded	<ul style="list-style-type: none"> — <i>CI_Trade_Tax.Category.Name.Text</i> Business Requirement 13/07/2008 CSC TAX0019 0..1 Tax category text
0 .. 1	<ul style="list-style-type: none"> — <i>CI_Trade_Tax.Due.Date.Type.Code</i>

Occurrence	Element/Attribute
0 .. 1	Business Requirement 13/07/2008 CSC TAX0022 0..1 Tax Due Date Type Code CI Trade Tax. Rate Applicable. Percent
0 .. unbounded	Business Requirement 13/07/2008 CSC TAX0022 0..1 Tax Due Date Type Code CI Trade Tax. Specified. CI Trade Accounting Account Main::CI_Trade_Accounting Account. Details
0 .. 1	Business Requirement 13/07/2008 CSC TAX0022 0..1 Tax Due Date Type Code CI Trade Tax. Buyer Deductible Tax Specified. CI Trade Accounting Account Main::CI_Trade_Accounting Account. Details
0 .. 1	Business Requirement 13/07/2008 CSC TAX0008 0..* Accounting Account CI Trade Tax. Buyer Non-Deductible Tax Specified. CI Trade Accounting Account Main::CI_Trade_Accounting Account. Details
0 .. 1	Business Requirement 13/07/2008 CSC TAX0008 0..* Accounting Account CI Trade Tax. Buyer Repayable Tax Specified. CI Trade Accounting Account Main::CI_Trade_Accounting Account. Details
0 .. 1	Business Requirement 13/07/2008 CSC TAX0008 0..* Accounting Account CI Trade Tax. Seller Payable Tax Specified. CI Trade Accounting Account Main::CI_Trade_Accounting Account. Details
0 .. 1	Business Requirement 13/07/2008 CSC TAX0008 0..* Accounting Account CI Trade Tax. Seller Refundable Tax Specified. CI Trade Accounting Account Main::CI_Trade_Accounting Account. Details
0 .. 1	Business Requirement 13/07/2008 CSC TAX0008 0..* Accounting Account CI Trade Tax. Service Supply. CI Trade Country Main::CI_Trade_Country. Details
0 .. unbounded	Business Requirement 13/07/2008 CSC TAX0023 0..1 Place of Supply CI Trade Tax. Place Applicable. CI Trade Location Main::CI_Trade_Location. Details

Occurrence	Element/Attribute
CI_ Universal_ Communication. Details	
0 .. 1	<ul style="list-style-type: none"> — <i>CI_ Universal_ Communication. URI. Identifier</i> Business Requirement 12/07/2008 CSC COM0002 0..1 URI identifier
0 .. 1	<ul style="list-style-type: none"> — <i>CI_ Universal_ Communication. Channel. Code</i> Business Requirement 12/07/2008 CSC COM0004 0..1 Channel Code
0 .. 1	<ul style="list-style-type: none"> — <i>CI_ Universal_ Communication. Complete Number. Text</i> Business Requirement 12/07/2008 CSC COM0005 0..1 Complete Number

Occurrence	Element/Attribute
Financial Institution_ Address. Details	
0 .. 1	— <i>Financial Institution_ Address. Postcode. Code</i>
0 .. 1	— <i>Financial Institution_ Address. Building Number. Text</i>
0 .. 1	— <i>Financial Institution_ Address. Line One. Text</i>
0 .. 1	— <i>Financial Institution_ Address. Line Two. Text</i>
0 .. 1	— <i>Financial Institution_ Address. Line Three. Text</i>
0 .. 1	— <i>Financial Institution_ Address. Line Four. Text</i>
0 .. 1	— <i>Financial Institution_ Address. Line Five. Text</i>
0 .. 1	— <i>Financial Institution_ Address. Street Name. Text</i>
0 .. 1	— <i>Financial Institution_ Address. City Name. Text</i>
0 .. 1	— <i>Financial Institution_ Address. Country Sub-Division. Identifier</i>
0 .. 1	— <i>Financial Institution_ Address. Country. Identifier</i>
0 .. 1	— <i>Financial Institution_ Address. Type. Code</i>
0 .. 1	— <i>Financial Institution_ Address. Department Name. Text</i>
0 .. 1	— <i>Financial Institution_ Address. Post Office Box. Text</i>
0 .. 1	— <i>Financial Institution_ Address. City. Identifier</i>
0 .. 1	— <i>Financial Institution_ Address. Country Sub-Division Name. Text</i>
0 .. 1	— <i>Financial Institution_ Address. Country Name. Text</i>

Occurrence	Element/Attribute
Referenced_ Logistics_ Package. Details	
0 .. 1	Referenced_ Logistics_ Package. Item. Quantity
0 .. 1	Referenced_ Logistics_ Package. Level. Code
0 .. 1	Referenced_ Logistics_ Package. Type. Code
0 .. 1	Referenced_ Logistics_ Package. Sequence. Numeric
0 .. 1	Referenced_ Logistics_ Package. Identification. Identifier
0 .. 1	Referenced_ Logistics_ Package. Global_ Identification. Identifier
0 .. 1	Referenced_ Logistics_ Package. Parent_ Identification. Identifier
0 .. 1	Referenced_ Logistics_ Package. Series Start_ Identification. Identifier
0 .. 1	Referenced_ Logistics_ Package. Series End_ Identification. Identifier

Occurrence	Element/Attribute
	Specified_ Binary File. Details
0 .. unbounded	— <i>Specified_ Binary File. Identification. Identifier</i>
0 .. unbounded	— <i>Specified_ Binary File. Title. Text</i>
0 .. unbounded	— <i>Specified_ Binary File. Author Name. Text</i>
0 .. unbounded	— <i>Specified_ Binary File. Version. Identifier</i>
0 .. unbounded	— <i>Specified_ Binary File. File Name. Text</i>
0 .. unbounded	— <i>Specified_ Binary File. URI. Identifier</i>
0 .. unbounded	— <i>Specified_ Binary File. MIME. Code</i>
0 .. unbounded	— <i>Specified_ Binary File. Encoding. Code</i>
0 .. unbounded	— <i>Specified_ Binary File. Character Set. Code</i>
0 .. unbounded	— <i>Specified_ Binary File. Included. Binary Object</i>
0 .. unbounded	— <i>Specified_ Binary File. Access. Text</i>
0 .. unbounded	— <i>Specified_ Binary File. Description. Text</i>
0 .. unbounded	— <i>Specified_ Binary File. Size. Measure</i>
0 .. unbounded	— Specified_ Binary File. Access Availability. Specified_ Period
	Main::Specified_ Period. Details

Occurrence	Element/Attribute
	Trade Product_ Feature. Details
0 .. 1	— <i>Trade Product_ Feature. Identification. Identifier</i>
0 .. unbounded	— <i>Trade Product_ Feature. Description. Text</i>
0 .. unbounded	— <i>Trade Product_ Feature. Name. Text</i>
0 .. 1	— <i>Trade Product_ Feature. Type. Code</i>
0 .. unbounded	— <i>Trade Product_ Feature. Marketing Phrase. Text</i>
0 .. unbounded	— <i>Trade Product_ Feature. Marketing. Measure</i>

Occurrence	Element/Attribute
	Trade Settlement_ Financial Card. Details
0 .. 1	Trade Settlement_ Financial Card. Microchip. Indicator
0 .. 1	Trade Settlement_ Financial Card. Identification. Identifier
	Business Requirement
	20/05/2009 CSC FCA0001 0..1 Identification
0 .. 1	Trade Settlement_ Financial Card. Type. Code
	Business Requirement
	20/05/2009 CSC FCA0002 0..1 Type Code
0 .. 1	Trade Settlement_ Financial Card. Cardholder Name. Text
	Business Requirement
	20/05/2009 CSC FCA0003 0..1 Cardholder name
0 .. 1	Trade Settlement_ Financial Card. Expiry. Date
	Business Requirement
	20/05/2009 CSC FCA0004 0..1 Expiry Date
0 .. 1	Trade Settlement_ Financial Card. Verification. Numeric
0 .. 1	Trade Settlement_ Financial Card. Valid From. Date Time
0 .. unbounded	Trade Settlement_ Financial Card. Credit Limit. Amount
	Business Requirement
	20/05/2009 CSC FCA0005 0..* Credit Limit
0 .. unbounded	Trade Settlement_ Financial Card. Credit Available. Amount
	Business Requirement
	20/05/2009 CSC FCA0001 0..1 Identification
	20/05/2009 CSC FCA0006 0..* Available amount
0 .. 1	Trade Settlement_ Financial Card. Interest Rate. Percent
	Business Requirement
	20/05/2009 CSC FCA0007 0..1 Interest Rate

Occurrence	Element/Attribute
	Trade_ Product Warranty. Details
0 .. unbounded	Trade_ Product Warranty. Description. Text
0 .. 1	Trade_ Product Warranty. Providing. Trade_ Party Main::Trade_ Party. Details
0 .. 1	Trade_ Product Warranty. Validity. Specified_ Period Main::Specified_ Period. Details

Occurrence	Element/Attribute
	Universal_ Communication. Details
0 .. 1	<i>Universal_ Communication. URI. Identifier</i>
0 .. 1	<i>Universal_ Communication. Channel. Code</i>
0 .. 1	<i>Universal_ Communication. Local Number. Text</i>
0 .. 1	<i>Universal_ Communication. Complete Number. Text</i>
0 .. 1	<i>Universal_ Communication. Country Number. Code</i>
0 .. 1	<i>Universal_ Communication. Extension Number. Text</i>
0 .. 1	<i>Universal_ Communication. Area Number. Code</i>
0 .. unbounded	<i>Universal_ Communication. Access. Text</i>
0 .. 1	<i>Universal_ Communication. Use. Code</i>
0 .. 1	<i>Universal_ Communication. HTML Preferred. Indicator</i>
0 .. 1	Universal_ Communication. Usage. Specified_ Preference
	Main::Specified_ Preference. Details

8. Core components UN/CEFACT Registry version used

This RSM is based on the UN/CEFACT Core Component Library (CCL), version 09B.

9. Draft Core Component reference

All the Aggregate Business Information Entities (ABIES) which is required to reflect the business requirements of Cross Industry Catalogue V1 are defined in section 8 of this RSM and correspond to the same entries in CCL09B

10. Additional documentation

This section identifies any additional documentation that will be registered with the canonical model in respect to the BCCs or ACCs that have been provided for registration in the UN/CEFACT Registry.

Not applicable at this point in time.

11. Additional information

Message assembly Excel spread sheet:



MA

TBG1_RSM_Cross_Ini