

7 November 2000

## **AGREEMENT**

**CONCERNING THE ADOPTION OF UNIFORM TECHNICAL PRESCRIPTIONS  
FOR WHEELED VEHICLES, EQUIPMENT AND PARTS WHICH CAN BE FITTED  
AND/OR  
BE USED ON WHEELED VEHICLES AND THE CONDITIONS FOR RECIPROCAL  
RECOGNITION  
OF APPROVALS GRANTED ON THE BASIS OF THESE PRESCRIPTIONS \*/**

(Revision 2, including the amendments entered into force on 16 October 1995)

---

### **Addendum 40: Regulation No. 41**

#### **Revision 1 - Amendment 1**

03 series of amendments - Date of entry into force: 5 February 2000

**UNIFORM PROVISIONS CONCERNING THE APPROVAL OF MOTORCYCLES  
WITH REGARD TO NOISE**



**UNITED NATIONS**

---

\*/ Former title of the Agreement:

Agreement Concerning the Adoption of Uniform Conditions of Approval and Reciprocal Recognition of Approval for Motor Vehicle Equipment and Parts, done at Geneva on 20 March 1958.

GE.00-

List of contents, Annexes:

Annex 4 (former), renumber as Annex 6.

Insert the title of a new Annex 4, to read:

"Annex 4 - Test track specifications".

Text of the Regulation,

General amendment:

Throughout the Regulation, replace the words "silencing system(s)" by "exhaust or silencing system(s)"

Paragraphs 2.2. to 2.5., amend to read :

- "2.2.        "type of motorcycle as regards its sound level and exhaust system"  
means motorcycles which do not differ in such essential respects as  
the following:
- 2.2.1.       the type of engine (two-stroke or four-stroke, reciprocating piston  
engine or rotary-piston engine, number and capacity of cylinders,  
number and type of carburettors or injection systems, arrangement of  
valves, net maximum power and corresponding speed).  
For rotary-piston engines the cubic capacity should be taken to be  
double of the volume of the chamber;
- 2.2.2.       transmission system, in particular the number and ratios of the  
gears;
- 2.2.3.       number, type and arrangement of exhaust systems.
- 2.3.        "Exhaust or silencing system" means a complete set of components  
necessary to limit the noise caused by a motorcycle engine and its  
exhaust.
- 2.3.1.       "Original exhaust or silencing system" means a system of a type  
fitted to the vehicle at the time of type-approval or extension of  
type-approval. It may be original or a replacement.
- 2.3.2.       "Non-original exhaust or silencing system" means a system of a type  
other than that fitted to the vehicle at the time of type-approval  
or extension of type-approval. It may be used only as a replacement  
exhaust or silencing system.
- 2.4.        "Exhaust or silencing systems of differing types" means systems  
which are fundamentally different in one of the following ways:
- 2.4.1.       systems comprising components bearing different factory or trade  
marks;
- 2.4.2.       systems comprising any component made of materials of different

characteristics or comprising components which are of a different shape or size;

- 2.4.3. systems in which the operating principles of at least one component are different;
- 2.4.4. systems comprising components in different combinations.
- 2.5. "Component of an exhaust system" means one of the individual components which together form the exhaust system (such as exhaust pipework, the silencer proper) and the intake system (air filter) if any.

If the engine has to be equipped with an intake system (air filter and/or intake noise absorber) in order to comply with the maximum permissible sound levels, the filter and/or absorber must be treated as components having the same importance as the exhaust system."

Insert new paragraphs 4.1.4. and 4.1.5. , to read :

- "4.1.4. All original silencers must bear the 'E' mark followed the identification of the country which granted the component type-approval. This reference must be legible and indelible and also visible in the position at which it is to be fitted.
- 4.1.5. Any packing of original replacement silencer systems must be marked legibly with the words 'original part' and the make and type references integrated together with the 'E' mark and also the reference of the country of origin."

Paragraph 5.4.1. footnote 2/, amend to read:

"2/ 1 for Germany, ... 24 for Ireland, ... 27 for Slovakia, 28 for Belarus, 29 for Estonia, 30 (vacant), 31 for Bosnia and Herzegovina, 32 for Latvia, 33 (vacant), 34 for Bulgaria, 35-36 (vacant), 37 for Turkey, 38-39 (vacant), 40 for the former Yugoslav Republic of Macedonia, 41 (vacant), 42 for the European Community (Approvals are granted by its Member States using their respective ECE symbol), 43 for Japan, 44 (vacant), 45 for Australia and 46 for Ukraine. Subsequent numbers shall be assigned to other countries in the chronological order in which they ratify the Agreement Concerning the Adoption for Uniform Technical Prescriptions for Wheeled Vehicles, Equipment and Parts which can be fitted and/or be Used on Wheeled Vehicles, and the Conditions for Reciprocal Recognition of Approval Granted on the Basis of these Prescriptions, and the numbers thus assigned shall be communicated by the Secretary-General of the United Nations to the Contracting Parties to the Agreement."

Paragraphs 6.1.1. and 6.1.2., should be deleted.

Paragraph 6.1.3., renumber as paragraph 6.1.1. and delete subparagraph (d).

Paragraph 6.2.1.3., replace "Annex 4" by "Annex 6".

Paragraph 6.3.2. , amend to read:

- "6.3.2. A diagram and a cross-sectional drawing indicating the dimensions of

the exhaust system shall be appended to the certificate referred to in annex 1."

Paragraph 7, amend to read :

"7. MODIFICATION AND EXTENSION OF THE APPROVAL OF THE MOTORCYCLE TYPE OR OF THE TYPE OF EXHAUST OR SILENCING SYSTEM(S)"

Insert a new paragraph 7.3., to read :

"7.3. The competent authority which issued the approval extension shall assign a serial number to the extension and shall so notify the other Parties to the 1958 Agreement applying this Regulation, by means of a communication form conforming to the model in annex 1 to this Regulation."

Paragraph 8., amend to read :

"8. CONFORMITY OF PRODUCTION

The conformity of production procedures shall comply with those set out in the Agreement, Appendix 2 (E/ECE/324-E/ECE/TRANS/505/Rev.2), with the following requirements :

- 8.1. Any motorcycle manufactured must conform to a type of motorcycle approved pursuant to this Regulation, be equipped with the silencer with which it was type-approved and satisfy the requirements paragraph 6 above.
- 8.2. In order to test conformity as required above, a sample motorcycle will be taken from the production line of the type approved pursuant to this Regulation. Production will be regarded as conforming to the provisions of this Regulation if the sound level measured using the method described in annex 3 does not exceed by more than 3 dB(A) the value measured at the time of type-approval, nor by more than 1 dB(A) the limits laid down in annex 6 of this Regulation."

Paragraphs 12. to 12.3., replace by the following text:

"12. TRANSITIONAL PROVISIONS

- 12.1. As from the official date of entry into force of the 03 series of amendments, no Contracting Parties applying this Regulation shall refuse to grant ECE approval under this Regulation as amended by the 03 series of amendments.
- 12.2. As from the date of entry into force of the 03 series of amendments, Contracting Parties applying this Regulation shall grant ECE approvals only if the motorcycle type to be approved meets the requirements of this Regulation as amended by the 03 series of amendments.
- 12.3. Contracting Parties applying this Regulation shall not refuse to grant extensions of approval in accordance with the preceding series of amendments to this Regulation.

- 12.4. Contracting Parties applying this Regulation shall continue to grant approvals to those types of motorcycles which conform to the requirements of this Regulation as amended by the preceding series of amendments until the entry into force of the 03 series of amendments.
- 12.5. ECE approvals granted under this Regulation before the entry into force of the 03 series of amendments and all extensions of such approvals, including those granted subsequently under a preceding series of amendments to this Regulation, shall remain valid indefinitely. When the motorcycle type approved under the preceding series of amendments meets the requirements of this Regulation as amended by the 03 series of amendments, the Contracting Party which granted the approval shall so notify the other Contracting Parties applying this Regulation.
- 12.6. No Contracting Party applying this Regulation shall refuse national type approval of a motorcycle type approved under the 03 series of amendments to this Regulation or meeting the requirements thereof.
- 12.7. As from 17 June 2003 Contracting Parties applying this Regulation may refuse first national registration (first entry into service) of a motorcycle which does not meet the requirements of the 03 series of amendments to this Regulation."

Annex 2, in the examples of Model A and Model B approval marks and in the text below, replace the approval number '022439' by '032439' and the words "02 series of amendments" amend to read to "03 series of amendments".

Annex 3, amend to read:

"Annex 3

METHODS AND INSTRUMENTS FOR MEASURING NOISE MADE BY MOTOR CYCLES

1. Noise of the motorcycle in motion (measuring conditions and method for testing of the vehicle during component type approval).
- 1.1. Limits: see annex 6
- 1.2. Measuring instruments
- 1.2.1. Acoustic measurements

The apparatus used for measuring the sound level shall be a precision sound-level meter of the type described in International Electrotechnical Commission (IEC) publication 179 "Precision sound-level meters", second edition.

Measurements shall be carried out using the 'fast' response of the sound-level meter and the 'A' weighting also described in that publication.

At the beginning and end of each series of measurements the sound-level meter shall be calibrated in accordance with the manufacturer's instructions, using an appropriate sound source (e.g.

pistonphone).

1.2.2. Speed measurements

Engine speed and motorcycle speed on the test track shall be determined to within  $\pm 3$  per cent.

1.3. Conditions of measurement

1.3.1. Condition of the motorcycle

During the measurements the motorcycle shall be in running order (including coolant, oils, fuel, tools, spare wheel and rider).

Before the measurements are made the motorcycle shall be brought to the normal operating temperature. If the motorcycle is fitted with fans with an automatic actuating mechanism, this system shall not be interfered with during the sound measurements. For motorcycles having more than one driven wheel, only the drive provided for normal road operation may be used. Where a motorcycle is fitted with a sidecar, this must be removed for the purposes of the test.

1.3.2. Test site

The test site shall consist of a central acceleration section surrounded by a substantially level test area. The acceleration section shall be level; its surface shall be dry and so designed that rolling noise remains low.

On the test site the variations in the free sound field between the sound source at the centre of the acceleration section and the microphone shall be maintained to within 1 dB. This condition will be deemed to be met if there are no large objects which reflect sound, such as fences, rocks, bridges or buildings, within 50 m of the centre of the acceleration section. The road surface covering of the test site shall conform to the requirements of annex 4.

The microphone shall not be obstructed in any way which could affect the sound field, and no person may stand between the microphone and the sound source. The observer carrying out the measurements shall take up position so as not to affect the readings of the measuring instrument.

1.3.3. Miscellaneous

Measurements shall not be made in poor atmospheric conditions. It shall be ensured that the results are not affected by gusts of wind.

For measurements, the A-weighted sound level of sound sources other than those of the motorcycle to be tested and of wind effects shall

be at least 10 dB(A) below the sound level produced by the motorcycle. A suitable windscreen may be fitted to the microphone provided that account is taken of its effect on the sensitivity and directional characteristics of the microphone.

If the difference between the ambient noise and the measured noise is between 10 and 16 dB(A), in order to calculate the test results the appropriate correction shall be subtracted from the readings on the sound-level meter, as in the following graph:

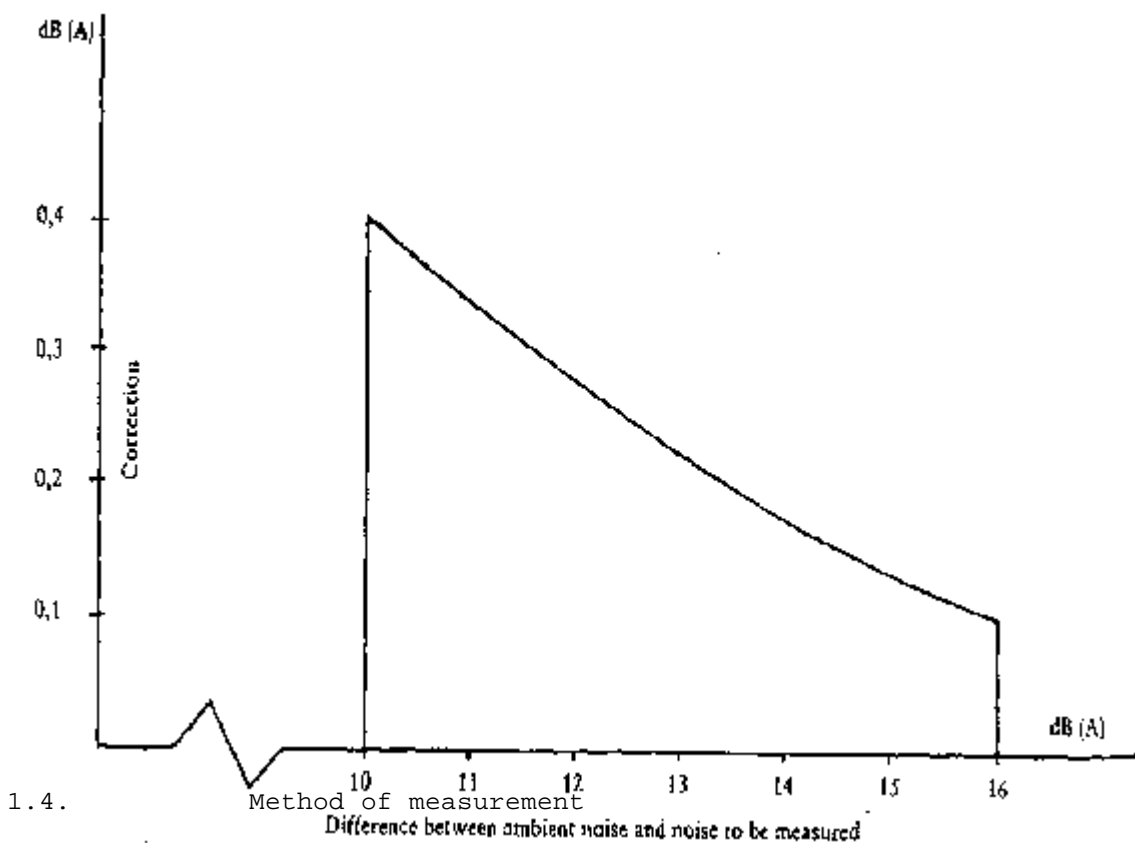

The maximum sound level expressed in A-weighted decibels (dB(A)) shall be measured as the motorcycle travels between lines AA' and BB' (figure 1). The measurement will be invalid if an abnormal discrepancy between the peak value and the general

sound level is recorded.

At least two measurements shall be taken on each side of the motorcycle.

1.4.2. Positioning of the microphone

The microphone shall be located  $7,5 \text{ m} \pm 0,2 \text{ m}$  from the reference line CC (see appendix - Figure 1) of the track and  $1.2 \text{ m} \pm 0,1 \text{ m}$  above ground level.

1.4.3. Conditions of operation

The motorcycle shall approach line AA' at an initial steady speed as specified in 1.4.3.1 and 1.4.3.2. When the front of the motorcycle reaches line AA' the throttle shall be fully opened as quickly as practically possible and kept in that position until the rear of the motorcycle reaches line BB'; the throttle must then be returned as quickly as possible to the idle position.

For all measurements the motorcycle must be ridden in a straight line over the acceleration section keeping the longitudinal median plane of the motorcycle as close as possible to line CC'.

1.4.3.1. Motorcycles with non-automatic gearboxes

1.4.3.1.1. Approach speed

The motorcycle shall approach line AA' at a steady speed of:

(i) 50 km/h

or

(ii) speed corresponding to an engine speed equal to 75 per cent of the speed specified under item 9 of annex 1.

The lower of these speeds shall be selected.

1.4.3.1.2. Selection of gear ratio

1.4.3.1.2.1. Motorcycles fitted with a gearbox having a maximum of four ratios, whatever the cylinder capacity of their engines, shall be tested only in second gear.

1.4.3.1.2.2. Motorcycles fitted with engines having a cylinder capacity not exceeding  $175 \text{ cm}^3$  and a gearbox with five ratio or more shall be tested only in third gear.

1.4.3.1.2.3. Motorcycles fitted with engines having a cylinder capacity of more than  $175 \text{ cm}^3$  and a gearbox with five ratios or more shall be tested once in second gear and once in third gear. The result used must be the average of the two tests.

1.4.3.1.2.4. If, during the test carried out in second gear (see paragraphs 1.4.3.1.2.1. and 1.4.3.1.2.3), the engine speed on the approach to the line marking the end of the test track exceeds 100 per cent of the speeds specified under item 9 of annex 1, the test must be carried out in third gear and the sound level measured shall be the only one recorded as the test result.

1.4.3.2. Motorcycles with automatic gearboxes

1.4.3.2.1. Motorcycles without a manual selector

1.4.3.2.1.1. Approach speed

The motorcycle shall approach line AA' at steady speeds of 30, 40 and 50 km/h or 75 per cent of the maximum road speed if that value is lower. The condition giving the highest sound level is chosen.

1.4.3.2.2. Motorcycles equipped with a manual selector with X forward drive positions.

1.4.3.2.2.1. Approach speed

The motorcycle shall approach line AA' at a steady speed of:

- (i) less than 50 km/h, the engine rotation speed being equal to 75 per cent of the speed specified under item 9 of annex 1, or
- (ii) 50 km/h, the engine rotation speed being less than 75 per cent of the speed specified under item 9 of annex 1.

If, in the test at a steady speed of 50 km/h, the gears change down to first, the approach speed of the motorcycle may be increased to a maximum of 60 km/h to avoid the change down.

1.4.3.2.2.2. Position of the manual selector

If the motorcycle is equipped with a manual selector with X forward drive positions, the test shall be carried out with the selector in the highest position; the voluntary device for changing down (e.g. kickdown) shall not be used. If an automatic change down takes place after line AA', the test shall be begun again using the second highest position or the third-highest position if necessary, in order to find the highest position of the selector at which the test can be performed without an automatic change down (without using the kickdown).

1.5. Results

1.5.1. The communication referred to in annex 1 shall indicate any circumstances and influences affecting the results of the measurements.

1.5.2. Readings taken shall be rounded off to the nearest decibel.

If the figure following the decimal point is between 0 and 4, the total is rounded down and if between 5 and 9, it is rounded up.

Only those measurements whose variation in two consecutive tests on the same side of the motorcycle is less than or equal to 2 dB(A) may be used for the purpose of issuing the communication referred to in annex 1.

1.5.3. To take account of inaccuracies in the measurements, the result of each measurement shall be arrived at by deducting 1 dB(A) from the value obtained in accordance with 1.5.2.

1.5.4. If the average of the four results of the measurements does not exceed the maximum permissible level for the category to which the motorcycle being tested belongs, the limit laid down in paragraph 1.1. will be deemed as being complied with. This average value will constitute the result of the test.

2. Noise from stationary motorcycle (measuring conditions and method for testing of the vehicle in use).

2.1. Sound-pressure level in the immediate vicinity of the motorcycle

In order to facilitate subsequent noise tests on motorcycles in use, the sound-pressure level shall also be measured in the immediate vicinity of the exhaust-system outlet in accordance with the following requirements, the result of the measurement being entered in the communication referred to in annex 1.

2.2. Measuring instruments

A precision sound-level meter as defined in paragraph 1.2.1. shall be used.

2.3. Conditions of measurement

2.3.1. Condition of the motorcycle

Before the measurements are made the motorcycle engine shall be brought to the normal operating temperature.

If the motorcycle is fitted with fans with an automatic actuating mechanism, this system shall not be interfered with during the sound measurements.

During the measurements the gearbox shall be in neutral gear. If it is impossible to disconnect the transmission, the driving wheel of the motorcycle shall be allowed to rotate freely, for example by placing the vehicle on its centre stand.

2.3.2. Test site (See appendix - figure 2)

Any area in which there are no significant acoustic disturbances may be used as a test site. Flat surfaces which are covered with concrete, asphalt or some other hard material and are highly reflective are suitable; surfaces consisting of earth which has been tamped down shall not be used. The test site must be in the form of a rectangle whose sides are at least 3 m from the outer edge of the motorcycle (handlebars excluded). There shall be no significant obstacles, e.g. no persons other than the rider and the observer may stand within this rectangle.

The motorcycle shall be positioned within the said rectangle so that the microphone used for measurement is at least 1 m from any kerb.

2.3.3. Miscellaneous

Readings of the measuring instrument caused by ambient noise and wind effects shall be at least 10 dB(A) lower than the sound levels to be measured. A suitable windshield may be fitted to the microphone provided that account is taken of its effect on the sensitivity of the microphone.

2.4. Method of measurement

2.4.1. Nature and number of measurements

The maximum sound level expressed in A-weighted decibels (dB(A)) shall be measured during the period of operation laid down in paragraph 2.4.3. At least three measurements shall be taken at each measuring point.

2.4.2. Positioning of the microphone (See appendix - figure 2)

The microphone shall be positioned level with the exhaust outlet or 0.2 m above the surface of the track, whichever is the highest. The microphone diaphragm shall face towards the exhaust outlet at a distance of 0.5 m from it. The axis of maximum sensitivity of the microphone shall be parallel to the surface of the track at an angle of  $45^{\circ} \pm 10'$  to the vertical plane of the direction of the exhaust emissions.

In relation to this vertical plane, the microphone shall be located on the side which gives the maximum possible distance between the microphone and the outline of the motorcycle (handlebars excluded).

If the exhaust system has more than one outlet at centres less than 0.3 m apart, the microphone shall be faced towards the outlet which is nearest the motorcycle (handlebars excluded) or towards the outlet which is highest above the surface of the track. If the centres of the outlets are more than 0.3 m apart, separate measurements shall be taken for each of them, the

highest figure recorded being taken as the test value.

2.4.3. Operating conditions

The engine speed shall be held steady at one of the following values:

$S/2$  if  $S$  is more than 5000 rpm,

$3S/4$ , if  $S$  is not more than 5000 rpm

where  $S$  is the speed specified under item 9 of annex 1.

When a constant engine speed is reached, the throttle shall be returned swiftly to the idle position. The sound level shall be measured during an operating cycle consisting of a brief period of constant engine speed and throughout the deceleration period, the maximum sound level meter reading being taken as the test value.

2.5. Results

2.5.1. The Communication referred to in annex 1 shall indicate all relevant data and particularly those used in measuring the noise of the stationary motorcycle.

2.5.2. Values, rounded off to the nearest decibel, shall be read off the measuring instrument. If the figure following the decimal point is between 0 and 4, the total is rounded down and if between 5 and 9, it is rounded up.

Only those measurements which vary by no more than 2 dB(A) in three consecutive tests will be used.

2.5.3. The highest of the three measurements will constitute the test result.

Figure 2  
Test for stationary vehicle

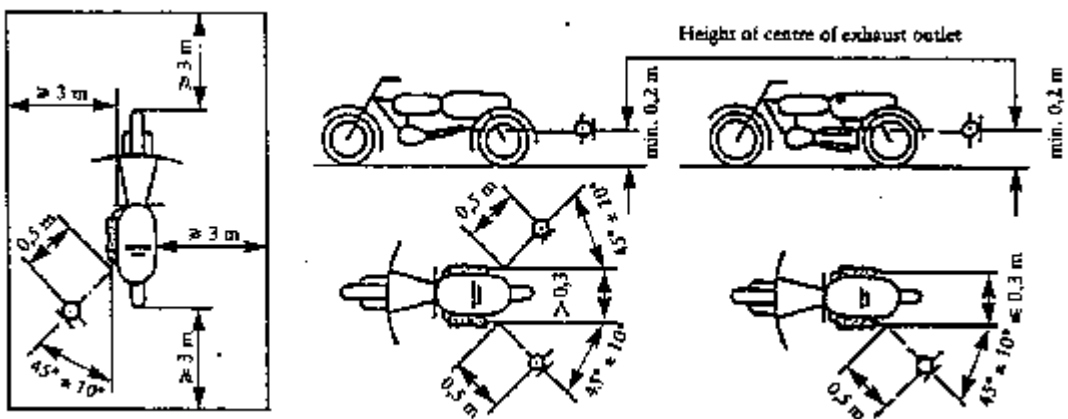

Insert the following new Annex 4:

"Annex 4

SPECIFICATIONS FOR THE TEST SITE

1. Introduction

This annex describes the specifications relating to the physical characteristics and the laying of the test track. These specifications, based on a special standard, 1/ describe the required physical characteristics as well as the test methods for these characteristics.

2. Required characteristics of the surface

A surface is considered to conform to this standard provided that the texture and voids content or sound absorption coefficient have been measured and found to fulfil [all] the requirements of paragraphs 2.1. to 2.4. below and provided that the design requirements (para. 3.2.) have been met.

2.1. Residual voids content

The residual voids content,  $V_c$ , of the test track paving mixture shall not exceed 8 per cent. For the measurement procedure, see paragraph 4.1.

2.2. Sound absorption coefficient

If the surface fails to conform to the residual voids content requirement, the surface is acceptable only if its sound absorption coefficient,  $\alpha$ ,  $\geq 0.10$ . For the measurement procedure, see paragraph 4.2. The requirement of paragraphs 2.1. and 2.2. is met also if only sound absorption has been measured and found to be  $\alpha \geq 0.10$ .

Note: The most relevant characteristic is the sound absorption, although the residual voids content is more familiar among road constructors. However, sound absorption needs to be measured only if the surface fails to conform to the voids requirement. This is because the latter is connected with relatively large uncertainties in terms of both measurements and relevance and some surfaces may therefore be rejected erroneously when the voids measurement only is used as a basis.

2.3. Texture depth

The texture depth (TD) measured according to the volumetric method (see para. 4.3. below) shall be:

TD  $\geq$  0.4 mm

2.4. Homogeneity of the surface

Every practical effort shall be taken to ensure that the surface is made to be as homogeneous as possible within the test area. This includes the texture and voids content, but it should also be observed that if the rolling process results in more effective rolling at some places than others, the texture may be different and unevenness causing bumps may also occur.

2.5. Period of testing

In order to check whether the surface continues to conform to the texture and voids content or sound absorption requirements stipulated in this standard, periodic testing of the surface shall be done at the following intervals:

(a) For residual voids content or sound absorption:

when the surface is new;  
if the surface meets the requirements when new, no further periodical testing is required. If it does not meet the requirement when it is new, it may do later because surfaces tend to become clogged and compacted with time.

(b) For texture depth (TD):

when the surface is new;  
when the noise testing starts (NB: not before four weeks after laying);  
then every 12 months.

3. Test surface design

3.1. Area

When designing the test track layout it is important to ensure that, as a minimum requirement, the area traversed by the vehicles running through the test strip is covered with the specified test material with suitable margins for safe and practical driving. This will require that the width of the track is at least 3 m and the length of the track extends beyond lines AA and BB by at least 10 m at either end. Figure 1 shows a plan of a suitable test site and indicates the minimum area which shall be machine laid and machine compacted with the specified test surface material. According to annex 3, paragraph 3.1.1.1., measurements have to be made on each side of the vehicle. This can be made either by measuring with two microphone locations (one on each side of the track) and driving in one direction, or measuring with a microphone only on one side of the track but driving the vehicle in two directions. If the former method is used, then there are no surface requirements on that side of the track where there is no microphone.

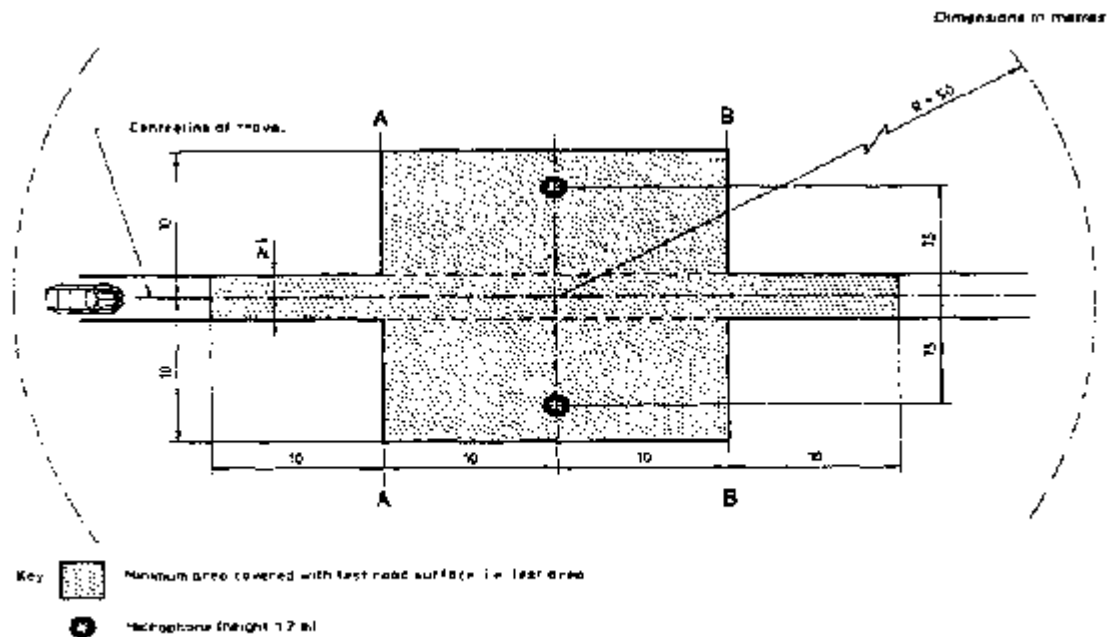

**Figure 1:** Minimum requirements for test surface area. The shaded part is called "Test Area".

### 3.2. Design and preparation of the surface

#### 3.2.1. Basic design requirements

The test surface shall meet four design requirements:

- 3.2.1.1. It shall be a dense asphaltic concrete.
- 3.2.1.2. The maximum chipping size shall be 8 mm (tolerances allow from 6.3 to 10 mm).
- 3.2.1.3. The thickness of the wearing course shall be  $\geq 30$  mm.
- 3.2.1.4. The binder shall be a straight penetration grade bitumen without modification.

#### 3.2.2. Design guidelines

As a guide to the surface constructor, an aggregate grading curve which will give desired characteristics is shown in Figure 2. In addition, Table 1 gives some guidelines in order to obtain the desired texture and durability. The grading curve fits the following formula:

$$P (\% \text{ passing}) = 100 \cdot (d/d_{\max})^{1/2}$$

where:  $d$  = square mesh sieve size, in mm  
 $d_{max}$  = 8 mm for the mean curve  
 $d_{max}$  = 10 mm for the lower tolerance curve  
 $d_{max}$  = 6.3 mm for the upper tolerance curve

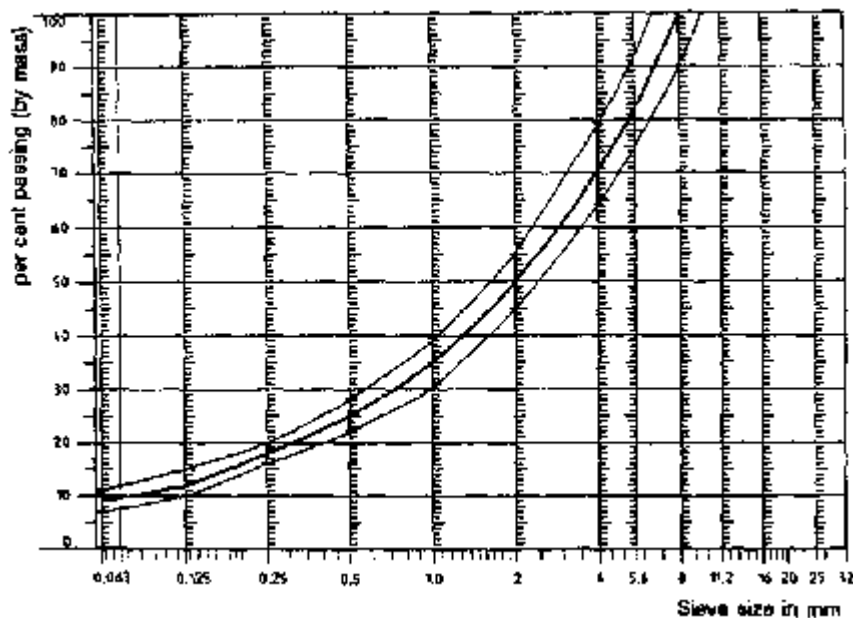

Figure 2: Grading curve of the aggregate in the asphaltic mix with tolerances

In addition to the above, the following recommendations are given:

The sand fraction (0.063 mm < square mesh sieve size < 2mm) shall include no more than 55% natural sand and at least 45% crushed sand;

The base and sub-base shall ensure a good stability and evenness, according to best road construction practice;

The chippings shall be crushed (100% crushed faces) and of a material with a high resistance to crushing;

The chippings used in the mix shall be washed;

No extra chippings shall be added onto the surface;

The binder hardness expressed as PEN value shall be 40-60, 60-80 or even 80-100 depending on the climatic conditions of the country. The rule is that as hard a binder as possible shall be used, provided this is consistent with common practice;

The temperature of the mix before rolling shall be chosen so as to

achieve by subsequent rolling the required voids content. In order to increase the probability of satisfying the specifications of paragraphs 2.1. to 2.4. above, the compactness shall be studied not only by an appropriate choice of mixing temperature, but also by an appropriate number of passings and by the choice of compacting vehicle.

Table 1: Design guidelines

	Target values		Tolerances
	By total mass of mix	By mass of the aggregate	
Mass of stones, square mesh sieve (SM) > 20 mm	47.0%	50.5%	± 5
Mass of sand 0.063 < SM < 2 mm	38.0%	40.2%	± 5
Mass of filler SM < 0.063 mm	8.8%	9.3%	± 2
Mass of binder (bitumen)	5.8%	N.A.	± 0.5
Max. chipping size	8 mm		6.3 - 10
Binder hardness	(see para. 3.2.2. (f))		
Polished stone value (PSV)	> 50		
Compactness, relative to Marshall compactness	98%		

4. Test method

4.1. Measurement of the residual voids content

For the purpose of this measurement, cores have to be taken from the track in at least four different positions which are equally distributed in the test area between lines AA and BB (see Figure 1). In order to avoid inhomogeneity and unevenness in the wheel tracks, cores should not be taken in wheel tracks themselves, but close to them. Two cores (minimum) should be taken close to the wheel tracks and one core (minimum) should be taken approximately midway between the wheel tracks and each microphone location.

If there is a suspicion that the condition of homogeneity is not met (see para. 2.4.), cores shall be taken from more locations within the test area. The residual voids content has to be determined for each core, then the average value from all cores shall be calculated and compared with the requirement of paragraph 2.1. In addition, no single core shall have a voids value which is higher than 10%. The test surface constructor is reminded of the problem which may arise when the test area is heated by pipes or electrical wires and cores must be taken from this area. Such installations must be carefully planned with respect to future core drilling locations. It is recommended to leave a few locations of size approximately 200 x 300 mm where there are no wires/pipes or where the latter are

located deep enough in order not to be damaged by cores taken from the surface layer.

4.2. Sound absorption coefficient

The sound absorption coefficient (normal incidence) shall be measured by the impedance tube method using the procedure specified in ISO 10534:1994 - "Acoustics - Determination of sound absorption coefficient and impedance by a tube method."

Regarding test specimens, the same requirements shall be followed as regarding the residual voids content (see para. 4.1.). The sound absorption shall be measured in the range between 400 Hz and 800 Hz and in the range between 800 Hz and 1,600 Hz (at least at the centre frequencies of third octave bands) and the maximum values shall be identified for both of these frequency ranges. Then these values, for all test cores, shall be averaged to constitute the final result.

4.3. Volumetric macro texture measurement

For the purpose of this standard, texture depth measurements shall be made on at least 10 positions evenly spaced along the wheel tracks of the test strip and the average value taken to compare with the specified minimum texture depth. For the description of the procedure see standard ISO 10844:1994.

5. Stability in time and maintenance

5.1. Age influence

In common with any other surfaces, it is expected that the tyre/road noise level measured on the test surface may increase slightly during the first 6-12 months after construction.

The surface will achieve its required characteristics not earlier than four weeks after construction. The influence of age on the noise from trucks is generally less than that from cars.

The stability over time is determined mainly by the polishing and compaction by vehicles driving on the surface. It shall be periodically checked as stated in paragraph 2.5.

5.2. Maintenance of the surface

Loose debris or dust which could significantly reduce the effective texture depth must be removed from the surface. In countries with winter climates, salt is sometimes used for de-icing. Salt may alter the surface temporarily or even permanently in such a way as to increase noise and is therefore not recommended.

5.3. Repaving the test area

If it is necessary to repave the test track, it is usually unnecessary to repave more than the test strip (of 3 m width in Figure 1) where vehicles are driving, provided the test area outside the strip met the requirement of residual voids content or sound absorption when it was measured.

6. Documentation of the test surface and of tests performed on it

6.1. Documentation of the test surface

The following data shall be given in a document describing the test surface:

- 6.1.1. The location of the test track.
- 6.1.2. Type of binder, binder hardness, type of aggregate, maximum theoretical density of the concrete ( $D_R$ ), thickness of the wearing course and grading curve determined from cores from the test track.
- 6.1.3. Method of compaction (e.g. type of roller, roller mass, number of passes).
- 6.1.4. Temperature of the mix, temperature of the ambient air and wind speed during laying of the surface.
- 6.1.5. Date when the surface was laid and contractor.
- 6.1.6. All or at least the latest test results, including:
  - 6.1.6.1. The residual voids content of each core.
  - 6.1.6.2. The locations in the test area from where the cores for voids measurements have been taken.
  - 6.1.6.3. The sound absorption coefficient of each core (if measured). Specify the results both for each core and each frequency range as well as the overall average.
  - 6.1.6.4. The locations in the test area from where the cores for absorption measurement have been taken.
  - 6.1.6.5. Texture depth, including the number of tests and standard deviation.
  - 6.1.6.6. The institution responsible for tests according to paragraphs 6.1.6.1. and 6.1.6.2. and the type of equipment used.
  - 6.1.6.7. Date of the test(s) and date when the cores were taken from the test track.

6.2. Documentation of vehicle noise tests conducted on the surface

In the document describing the vehicle noise test(s) it shall be stated whether all the requirements of this standard were fulfilled or not. Reference shall be given to a document according to paragraph 6.1. describing the results which verify this."

Annex 6, amend to read:

"Annex 6

MAXIMUM LIMITS OF SOUND LEVEL (NEW MOTORCYCLES)

Category of motorcycle	Engine cylinder capacity (cc)	Values expressed in dB(A)
First category	cc # 80 cm <sup>3</sup>	75
Second category	80 cm <sup>3</sup> < cc # 175 cm <sup>3</sup>	77
Third category	cc > 175 cm <sup>3</sup>	80

"

\_\_\_\_\_