

# Technical Aspects of Weighing Road Vehicles

BSEC Conference Geneva 18 June 2009





# Basic considerations

Weighing errors

Weighing methods

External errors

# Weighing errors

- All kind of measurement is affected by more or less errors.
- The scales must be tested on a regular basis in order to ensure an operation within the error limits.
- The correct working of a scales should also be be verified on a daily basis whenever possible (field test).

# Weighing methods

- Weighing in one operation is the traditional way. Only the gross weight can be determined! The accuracy is very good because it is not affected by external factors.
- Partial weighing axle by axle is the preferred mode for mobile weighing. The result can be affected by external factors.
- External errors are produced by unfavourable characteristics of the vehicle and weighing site.



# Weighing in one Operation

No external errors

# Typical case: Platform scale

Seite: 6

- A verified platform scale shows results within the error band regardless of the position of the truck on the platform.
- No special precautions are necessary.
- Only the platform must be continuously checked to avoid that foreign objects do not disturb the proper functioning (e.g. stones in the gap between platform and surrounding pavement).
- It is an advantage to check the weighing results whenever possible.



## Rare case: Weighing with mobile Wheel Load Scales (same number of scales as wheels)

- Regarding the gross weight the same is true as for the platform scale.
- Additional errors only may occur if the wheel load scale is sensitive to uneven ground (which should not be the case!).
- In addition to the platform scale the axle loads can be determined. The axle loads may be affected by external errors





# Partial Weighing

Always affected with more or less external errors!

## Typical case: Two Wheel Load Scales and four levelling mats

- A two axle vehicle has got a well defined axle load distribution.
- The axle load distribution of vehicles with 3 and more axles may change each time the vehicle is stopped!
- Calculated gross weight: In the best case the variations of the axle loads are compensating, in the worst case they are accumulating.
- Mobile wheel load scales can be tested at any time in the field (Swapping the scales).



# Fixed installed axle load scales

- Basically the same is true as stated for two Wheel Load Scales!



## Rare case: Partial weighing on a small weighbridge

- Basically the same is true as stated for two Wheel Load Scales.
- Big errors may occur if the pavement before and after the scale is not level. Horizontal forces are disturbing the proper operation of the scale.



# External errors

What are the causes?

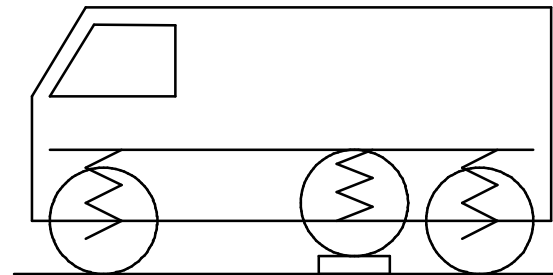
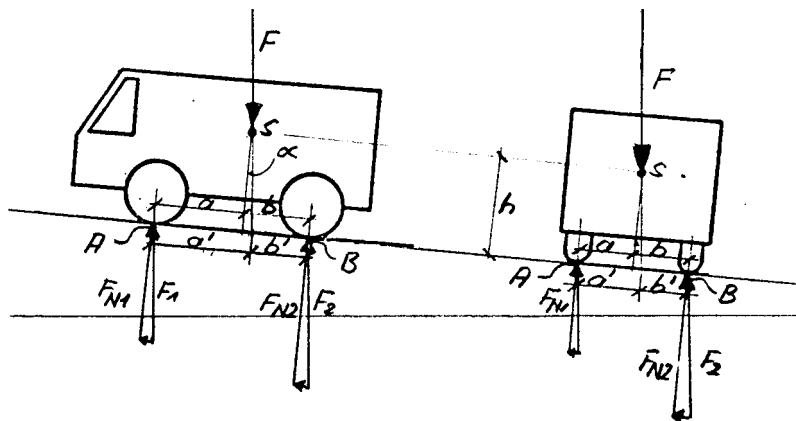

# Causes for external errors

- Gradient of the weighing site: Almost no influence on the gross weight. Influence on the axle weight if the slope is in the driving direction!
- The vehicle suspension: The compression of the suspension results in higher Axle load. Remedy: Levelling mats or flush installation.
- Friction in the suspension: Small influence if the vehicle is in good technical condition.
- Brake reaction forces: Braking causes load shift! Remedy: no braking while weighing!
- Vehicle oscillation (weighing in motion only): The axle load changes depending on the actual amplitude of the oscillation.
- Site unevenness



# Conclusions

The most important facts and figures regarding vehicle weighing

# The accuracy of the various weighing systems

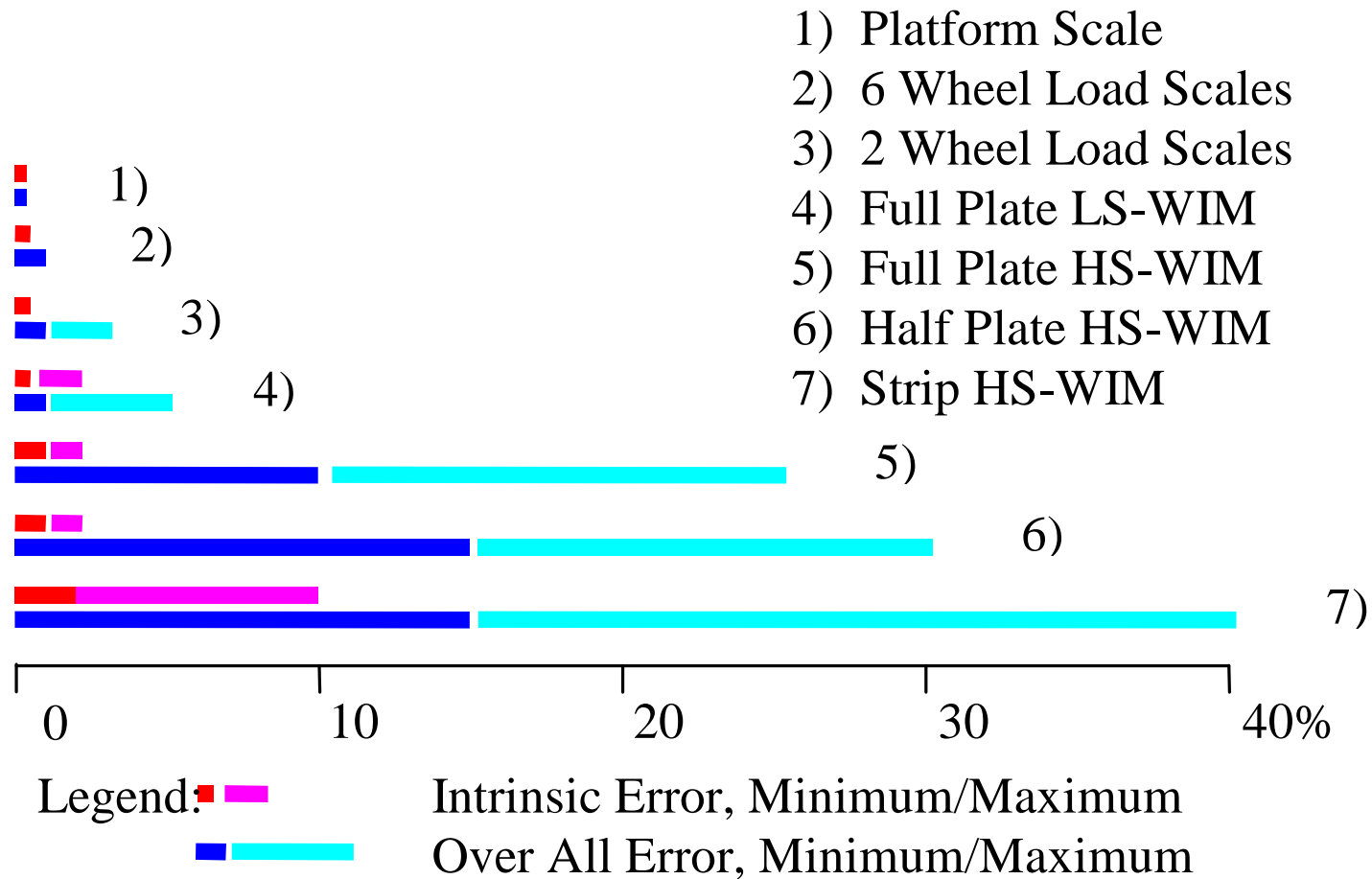

# How to ensure reliable weighing results

- Platform scales and weighing in one operation do not need special precautions!
- Partial weighing only reveals good results if the weighing procedure is strictly followed (level site, levelling out axle groups, no braking.....)
- A deduction according to the expected maximum error should be made in order to make sure that the driver is not punished for undue high weighing result.