

# Proposal how to structure the RESS safety requirements

Status: 24.03.2011

## Color-code:

- Red = RESS-3-7 Vibration\_Draft\_JP\_Proposal  
 Green = Remarks or amendments by the secretary  
 Purple = Remarks from TÜV and BMW under § 3.7

## Contents

1. Scope .....	- 3 -
2. Definitions .....	- 3 -
3.1 Vibration.....	- 5 -
3.1.1 Rationale .....	- 5 -
3.1.2 Requirement.....	- 5 -
3.1.3 Verification .....	- 9 -
3.2 Thermal Shock and Cycling .....	- 10 -
3.2.1 Rationale .....	- 10 -
3.2.2 Requirement.....	- 10 -
3.2.3 Verification .....	- 10 -
3.3 [Dewing (temperature change)].....	- 11 -
3.3.1 Rationale .....	- 11 -
3.3.2 Requirement.....	- 11 -
3.3.3 Verification .....	<b>Error! Bookmark not defined.</b>
3.4 Mechanical impact .....	- 12 -
3.4.1 Mechanical Shock .....	- 12 -
3.4.2 Mechanical integrity .....	- 15 -
3.5 Fire Resistance.....	- 17 -
3.5.1 Rationale .....	- 17 -
3.5.2 Requirement.....	- 17 -
3.5.3 Verification .....	- 19 -
3.6 External Short Circuit .....	- 20 -
3.6.1 Rationale .....	- 20 -
3.6.2 Requirement.....	- 20 -
3.6.3 Verification .....	- 20 -
3.7 Overcharge Protection (ISO 12405-1).....	- 21 -
3.7.1 Rationale .....	- 21 -
3.7.2 Requirement.....	- 21 -
3.7.3 Verification .....	- 22 -
3.8 Over-discharge Protection .....	- 23 -
3.8.1 Rationale .....	- 23 -
3.8.2 Requirement.....	- 23 -
3.8.3 Verification .....	- 23 -
3.9 Over-temperature Protection .....	- 24 -
3.9.1 Rationale .....	- 24 -
3.9.2 Requirement.....	- 24 -
3.9.3 Verification .....	- 24 -
3.10 Protection against direct contact (related to R100) .....	- 25 -
3.10.1 Rationale .....	- 25 -

## Proposal how to structure the RESS safety requirements

Status: 24.03.2011

<b>3.11</b>	<b>Emission</b> .....	- 26 -
<b>3.11.1</b>	<b>Rationale</b> .....	- 26 -
<b>3.11.2</b>	<b>Requirement</b> .....	- 26 -
<b>3.11.3</b>	<b>Verification</b> .....	- 26 -
	<b>Annex 1: Measurement of isolation resistance</b> .....	- 27 -
	<b>Annex 2: DIMENSIONS AND TECHNICAL DATA OF FIREBRICKS</b> .....	- 31 -
<b>B)</b>	<b>Additional Requirements?</b> .....	- 32 -
	<b>Immersion Test (RESS complete under water)</b> .....	- 32 -
	<b>[Dust]</b> .....	- 32 -
	<b>Marking</b> .....	- 32 -
	<b>EMC</b> .....	- 32 -

# Proposal how to structure the RESS safety requirements

Status: 24.03.2011

## 1. SCOPE

The following prescriptions apply to safety requirements with respect to the Rechargeable Energy Storage Systems [RESS] of road vehicles of categories M and N, equipped with one or more traction motor(s) operated by electric power and not permanently connected to the grid.

## 2. DEFINITIONS

### Remarks from Korea:

In some case of RESS, the tests proposed in the proposal may be hard to carry out due to the dimensions of a RESS.

If the RESS is installed in a regular bus, the RESS may be too big to handle in the test lab.

A new term represents the typical part of the RESS should be considered.

- 2.1 "Rechargeable energy storage system [RESS]" means the rechargeable energy storage system that provides electric energy for electric propulsion.[ The [RESS] includes a completely functional energy storage system consisting of the [pack(s)] and necessary ancillary subsystems for physical support, thermal management, electronic control and enclosures.]
- 2.2 "Cell" means a single encased electrochemical unit (one positive and one negative electrode) which exhibits a voltage differential across its two terminals.
- 2.3 "Lithium ion cell" means a rechargeable electrochemical cell whose electrical energy is derived from the insertion/extraction reactions of lithium ions between the anode and the cathode.
- 2.4 "Battery" means two or more cells which are electrically connected together fitted with devices necessary for use, for example, case, terminals, marking and protective devices.
- 2.5 "Battery enclosure" means the physical housing surrounding [RESS] components, particularly cells or [cell assemblies].
- 2.6 "Explosion" means very fast release of energy sufficient to cause pressure waves and/or projectiles that may cause considerable structural and/or bodily damage.
- 2.7 "Fire" means the emission of flames from a battery enclosure that may spread to the other part of the vehicle. Sparks are not flames.
- [2.8 "Cell rupture" means the mechanical failure of a cell container induced by an internal or external cause, resulting in exposure or spillage but not ejection of solid materials.] **Remark: not used for the moment in the text**

**Proposal how to structure the RESS safety requirements**

Status: 24.03.2011

- [2.9 "Battery enclosure rupture" means openings through the battery enclosure which are created or enlarged by an event and which are sufficiently large for a 50 mm diameter sphere to contact battery system internal components (see ISO20653, IPXXA).]
- 2.10 "Working voltage" means the highest value of an electrical circuit voltage root mean square (rms), specified by the manufacturer or determined by measurement, which may occur between any conductive parts in open circuit conditions or under normal operating condition. If the electrical circuit is divided by galvanic isolation, the working voltage is defined for each divided circuit, respectively.
- 2.11 "High Voltage" means the classification of an electric component or circuit, if it's working voltage is  $> 60 \text{ V}$  and  $\leq 1500 \text{ V DC}$  or  $> 30 \text{ V}$  and  $\leq 1000 \text{ V AC}$  root mean square (rms).
- [2.12 Nominal voltage is the voltage given by the supplier as the recommended operating voltage of their battery system] **Remark: not used for the moment in the text**
- 2.13 "Module" means.....
- 2.14 "Undefined venting" means ....
- 2.15 "Closed chemical process" means

## Proposal how to structure the RESS safety requirements

Status: 24.03.2011

### A) Technical Requirements Priority Requirements

#### 3.1 Vibration

##### 3.1.1 Rationale

Simulates a vibration environment which a [battery system] will likely experience during the lifetime of the vehicle. Vibration of the vehicle-body is random vibration induced by rough-road-driving as well as internal vibration of the power train. This test checks the [RESS] for specific malfunctions and breakage caused by this vibration.

The purpose of this test is to verify the safety performance of a RESS (or a sub-assembly of [RESS]) under a vibration environment.

##### 3.1.2 Requirement

###### 3.1.2.1 Conditions

The following test can be conducted with the [RESS] or with [module(s) of the RESS].

[If tests are performed on [module basis], evidence shall be provided that the results are representative for [RESS].]

Due to the big mass of this [RESS] the maximum test frequency is limited to 200 Hz, but the vibration test shall be performed in sequence in all three spatial directions.

Adjust the State of Charge (SOC) with discharge to [50 %] before starting the vibration test profile.

#### 2.2. State of charge of [RESS]

The state of charge (SOC) of DUT shall be at the maximum which is possible during normal vehicle operation. After the adjustment of SOC, the DUT shall be stored under the temperature of  $25^{\circ}\text{C} \pm 5^{\circ}\text{C}$  for more than 8 hours or until the temperature measured on DUT becomes stable within  $25^{\circ}\text{C} \pm 5^{\circ}\text{C}$  prior to initiation of the vibration.

The test shall be performed according

- to [IEC 60068-2-64], see Tables 1 to 4 or
- to a test profile determined by the vehicle-manufacturer, verified to the vehicle application and agreed by the Technical Service.

The [RESS] shall be mounted on a shaker test bench in a way that the load application is equivalent to the mounting in the vehicle.

The [module(s)] shall be mounted on a shaker test bench in a way that the load application is equivalent to each mounting position (tolerance to be defined) in the [RESS].

## Proposal how to structure the RESS safety requirements

Status: 24.03.2011

### 2.1. Installation of [RESS] for the test

For the purpose of this, the devices of [RESS] (or [sub-assembly(ies)] of [RESS]) subject to the vibration test shall be referred to as DUT (Device Under Test). DUT shall be firmly secured to the platform of the vibration machine in such a manner as to faithfully transmit the vibration. If certain electronic management unit for [RESS] is not integrated, such control unit may not be installed on DUT.

With only one test device the vibration test shall be performed in a sequence of all three spatial directions

- vertical direction (Z),
- transverse direction (Y) and
- longitudinal direction (X).

a) [The mechanical stresses acting on the [RESS] are specified by a stochastic acceleration - time function with test duration per spatial direction of 21 h. The test duration per spatial direction can be reduced to 15 h if the test procedure is performed with two identical [RESS] or to 12 h if the test procedure is performed with three identical [RESS], respectively.]

b) [The test duration per spatial direction is 12 h.]

For longitudinal direction (X) see table1, for transverse direction (Y) see table 2 or 3 and vertical direction (Z) see table 4.

[If the [RESS] is designed for a vehicle mounting position below the vehicle passenger compartment, then the reduced spectrum PSD\_horizontal\_transverse\_YPassenger\_compartment\_bottom according to Table 3 shall be used.]

Table 1  
Values for PSD\_horizontal\_longitudinal\_X

Frequency [Hz]	PSD [g <sup>2</sup> /Hz]	PSD [(m/s <sup>2</sup> ) <sup>2</sup> /Hz]
5	0,0125	1,20
10	0,03	2,89
20	0,03	2,89
200	0,00025	0,02
<hr/>		
RMS	0,96 g	9,42 m/s <sup>2</sup>

Table 2 — Values for PSD\_horizontal\_transvers\_Y

Frequency [Hz]	PSD [g <sup>2</sup> /Hz]	PSD [(m/s <sup>2</sup> ) <sup>2</sup> /Hz]
5	0,04	3,85
20	0,04	3,85
200	0,0008	0,08
<hr/>		
RMS	1,23 g	12,07 m/s <sup>2</sup>

**Proposal how to structure the RESS safety requirements**

Status: 24.03.2011

Table 3 — Values for PSD\_horizontal\_transvers\_Y Passenger\_compartment\_bottom

Frequency [Hz]	PSD [g <sup>2</sup> /Hz]	PSD [(m/s <sup>2</sup> ) <sup>2</sup> /Hz]
5	0,01	0,96
10	0,015	1,44
20	0,015	1,44
50	0,01	0,96
200	0,0004	0,04
<hr/>		
RMS	0,95 g	9,32 m/s <sup>2</sup>

Table 4 — Values for PSD\_vertical\_Z

Frequency [Hz]	PSD [g <sup>2</sup> /Hz]	PSD [(m/s <sup>2</sup> ) <sup>2</sup> /Hz]
5	0,05	4,81
10	0,06	5,77
20	0,06	5,77
200	0,0008	0,08
<hr/>		
RMS	1,44 g	14,13 m/s <sup>2</sup>

Figure 5 shows the interpolation between the data-points of tables 1 to 4.

Figure 5 — PSD spectra for sprung masses (masses mounted on vehicle body)

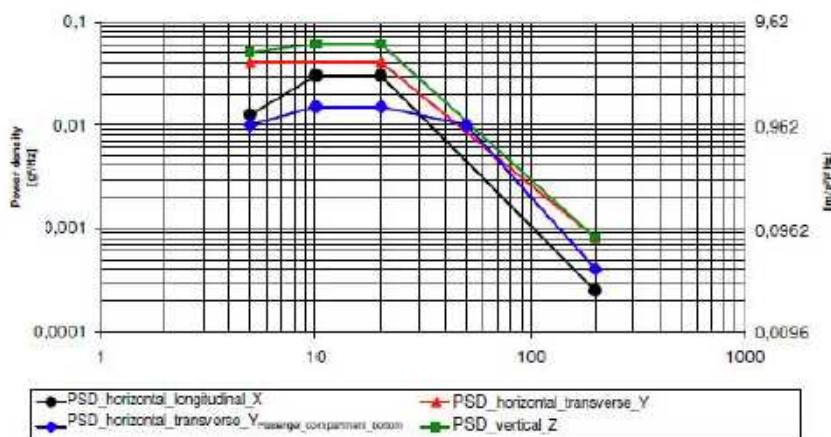

The following control parameters shall be ensured:

- Delta frequency 1,25 ± 0,25 Hz
- [- Inner range of tolerance ± 3 dB (warning level)
- Outer range of tolerance ± 6 dB (shut-down level)]

**2.3. Vibration**

The vibration shall be a sinusoidal waveform with a logarithmic sweep between 7 Hz and 200 Hz and back to 7 Hz traversed in 15 minutes. This cycle shall be repeated 12 times for a total of 3 hours for each of three mutually

## Proposal how to structure the RESS safety requirements

Status: 24.03.2011

perpendicular mounting positions of the [cell]. One of the directions of vibration must be perpendicular to the terminal face.

The logarithmic frequency sweep shall differ for DUT with a gross mass of not more than 12 kg (small DUT), and for DUT with a gross mass of 12 kg and greater (large DUT).

For small DUT: from 7 Hz a peak acceleration of 1  $g_n$  is maintained until 18 Hz is reached. The amplitude is then maintained at 0.8 mm (1.6 mm total excursion) and the frequency increased until a peak acceleration of 8  $g_n$  occurs (approximately 50 Hz). A peak acceleration of 8  $g_n$  is then maintained until the frequency is increased to 200 Hz.

For large DUT: from 7 Hz to a peak acceleration of 1  $g_n$  is maintained until 18 Hz is reached. The amplitude is then maintained at 0.8 mm (1.6 mm total excursion) and the frequency increased until a peak acceleration of 2  $g_n$  occurs (approximately 25 Hz). A peak acceleration of 2  $g_n$  is then maintained until the frequency is increased to 200 Hz.

At the end of the vibration test the isolation resistance has to be measured.

### 3.1. Records

Open circuit voltage of DUT shall be measured prior to initiation of vibration and after the vibration test.

Isolation measurement shall be done in accordance with ISO 6469-1, Section 6.1.3; or equivalent prior to initiation of vibration and after the vibration test.

#### 3.1.2.2 Acceptance criteria based on [RESS]

During the test, including [1] h after the test, the [battery system] shall exhibit no evidence of

- a) undefined venting
- b) battery enclosure rupture
- c) fire
- d) explosion.

For [RESS] using high voltage the isolation resistance measured at the end of the test shall maintain high voltage to ground isolation no less than 100  $\Omega$ /Volt.

#### 3.1.2.3 Acceptance criteria based on [modules]

During the test, including [1] h after the test, the [battery system] shall exhibit no evidence

- a) of undefined visible venting
- b) battery enclosure rupture (no degradation of protection degree)
- c) fire
- d) explosion.

During the test, the [RESS] (or the sub-assembly of RESS) shall exhibit no evidence of battery enclosure rupture, fire or explosion,

For [RESS] using high voltage the isolation resistance measured at the end of the test shall maintain no degradation of high voltage to ground isolation as defined by the battery-manufacturer.



## Proposal how to structure the RESS safety requirements

Status: 24.03.2011

and shall maintain high voltage to ground isolation no less than 100  $\Omega$ /volt. Post-test open circuit voltage shall be no less than 90% of the pre-test open circuit voltage.

### 3.1.3 Verification

a) to d) of 3.1.2.2 shall be checked by visual inspection.

The isolation resistance shall be measured according to Annex 1.

## Proposal how to structure the RESS safety requirements

Status: 24.03.2011

### **3.2**            **Thermal Shock and Cycling**

#### **3.2.1**            **Rationale**

Thermal shock cycling is performed to determine the resistance of the [RESS] to sudden changes in temperature. The [RESS] undergo a specified number of temperature cycles, which start at Room Temperature (RT) followed by high and low temperature cycling. It simulates a rapid environmental temperature change which a [battery system] will likely experience during its life.

#### **3.2.2**            **Requirement**

##### **3.2.2.1**            **Conditions**

[RESS] shall be stored for at least six hours at a test temperature equal to at a minimum of 70°C, followed by storage for at least six hours at a test temperature equal to or less than - 38°C. The maximum time interval between test temperature extremes is 30 minutes. This procedure is to be repeated at least 5 times, after which the [RESS] shall be stored for 24 hours at ambient temperature (20 ± 5 °C).

Direct after Thermal Shock and Cycling a standard charging has to be conducted if not inhibited by the [RESS].

##### **3.2.2.2**            **Acceptance criteria**

During the test, including [1] h after the test, the [battery system] shall exhibit no evidence of

- a) undefined visible venting
- b) battery enclosure rupture (no degradation of protection degree)
- c) fire
- d) explosion
- e) leakage.

For [RESS] using high voltage the isolation resistance measured at the end of the test shall maintain high voltage to ground isolation no less than 100 Ω/Volt.

#### **3.2.3**            **Verification**

a) to d) of 3.1.2.2 shall be checked by visual inspection.

The isolation resistance shall be measured according to Annex 1

**Proposal how to structure the RESS safety requirements**

Status: 24.03.2011

**3.3 Dewing (temperature change)**

**3.3.1 Rationale**

**3.3.2 Requirement**

**3.3.2.1 Conditions**

**3.3.2.2 Acceptance criteria**

**3.3.3 Verification]**

## Proposal how to structure the RESS safety requirements

Status: 24.03.2011

### 3.4 Mechanical impact

#### Remark from Korea:

#### §3. 4 Mechanical Impacts

The proposal suggests that the RESS be subject to pre-described acceleration

If this test is carried out, the RESS shall be on the sled. In that case, it is not know what will happen to the RESS. Of course, the manufacture may know what will happen based on his experience. However, there is a slim chance of fire or explosion. Thus it may be dangerous to carry out this sled test in the confined area.

A drop test in an open space, equivalent to the pre-describe acceleration, should be considered as an alternative or replacement.

### 3.4.1 Mechanical Shock

#### 3.4.1.1 Rationale

Simulates inertial loads which may occur during vehicle crash situation to [RESS].

#### 3.4.1.2 Requirement

##### 3.4.1.2.1 Conditions

For the longitudinal and lateral vehicle direction, one of the conditions described in 3.4.1.2.1.1 or 3.4.1.2.1.2 shall be applied.

##### 3.4.1.2.1.1 Vehicle based test

[RESS] installed in a vehicle that undergoes a vehicle crash test according to ECE-R12 Annex 3 or ECE-R 94 Annex 3 shall meet the acceptance criteria under 3.4.1.2.2.

This test is equivalent to the test conditions described in table 5 in 3.4.1.2.1.2.

[RESS] installed in a vehicle that undergoes a vehicle crash test according to ECE-R95 Annex 4 shall meet the acceptance criteria under 3.4.1.2.2.

This test is equivalent to the test conditions described in table 6 in 3.4.1.2.1.2.

The approval of the [RESS] tested under this condition is limited to the installation in the specific vehicle type.

##### 3.4.1.2.1.2 Component based test

A complete [RESS] is to be tested for this condition. However, if conducting this test on a [RESS] is deemed inappropriate due to size or weight, this test may be conducted utilizing [pack(s)], provided that all portions of the [battery system] are evaluated. If tests are performed on [pack basis], evidence shall be provided that the results are representative for [RESS].

[Pack(s)] have to be identified:

- For which vehicle category they are designed
- For which installation direction they are designed

Adjust the State of Charge (SOC) to a minimum 50 % before starting the impact test profile. The complete [RESS or pack(s)] shall be applied to the shock levels described in Table 5 and 6 in both positive and negative directions.

**Proposal how to structure the RESS safety requirements**

Status: 24.03.2011

For every of the 4 evaluation conditions, a separate [RESS or pack(s)] can be used. The [RESS or pack(s)] shall be connected to the test fixture only by the intended mounting methods.

Table 5 – Shock levels in direction of travel

	Acceleration
[RESS] fitted vehicles of categories M1 and N1	20g
[RESS] fitted vehicles of categories M2 and N2	10g
[RESS] fitted vehicles of categories M3 and N3	6.6g

Table 6 – Shock levels horizontally perpendicular to the direction of travel

	Acceleration
[RESS] fitted vehicles of categories M1 and N1	8g
[RESS] fitted vehicles of categories M2 and N2	5g
[RESS] fitted vehicles of categories M3 and N3	5g

The characteristic shock curve shall meet one of the following two alternatives:

- a) The test pulse shall circumscribe the minimum shock pulse described in diagram 1. The pulse shall start between 0ms and 20ms; the end of the pulse shall be between 100ms and 120ms. The duration of the shock level shall be at least 15ms.

Diagram 1 – minimum shock pulse

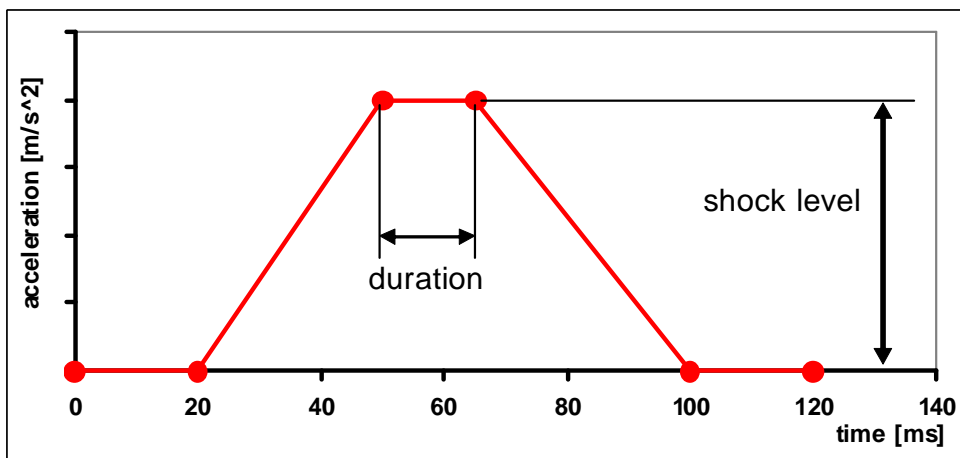

## Proposal how to structure the RESS safety requirements

Status: 24.03.2011

- b) The test pulse shall describe a half sinus with duration of 15ms between 10% and 90% of the shock level.

Diagram 2 – sinus shock pulse

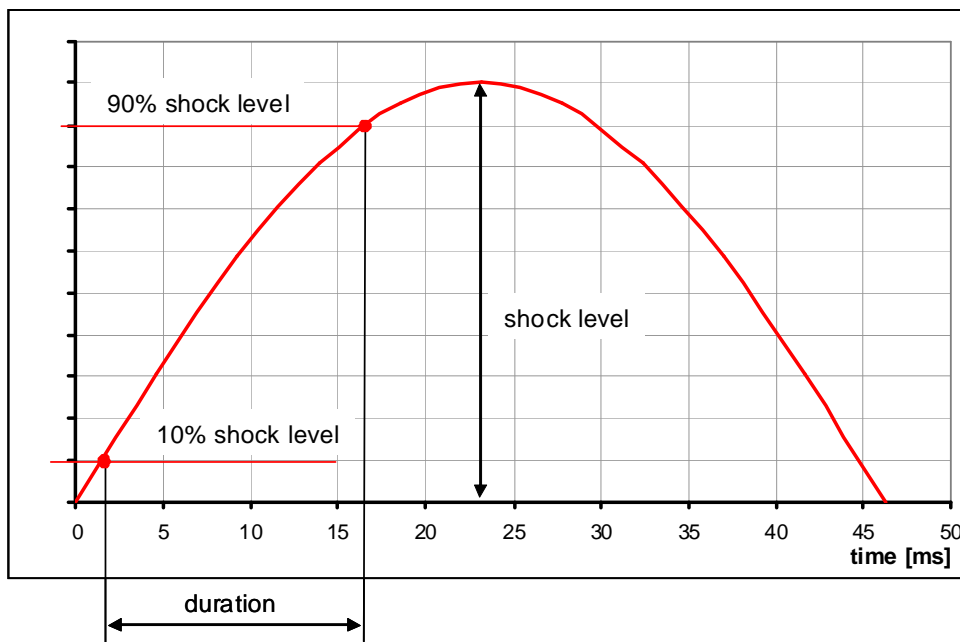

### 3.4.1.2.2 Acceptance criteria

During the test, including 6 h after the test, the [RESS or pack(s)] shall exhibit no evidence of

- a) undefined visible venting
- b1) [RESS] enclosure rupture (protection degree not less than IPXXB)
- b2) [Pack(s)] enclosure ruptures (no degradation of protection degree against direct contact)
- c) fire
- d) explosion.

The [RESS or pack(s)] shall be retained at its mounting locations and components shall remain inside its boundaries.

### 3.4.1.3 Verification Method

- a) to d) of 3.4.1.2.2 shall be checked by visual inspection.

## Proposal how to structure the RESS safety requirements

Status: 24.03.2011

### 3.4.2 Mechanical integrity

#### 3.4.2.1 Rationale

Simulates contact loads which may occur during vehicle crash situation to [RESS].

#### 3.4.2.2 Requirement

##### 3.4.2.2.1 Conditions

The test applies only to [RESS] intended to be installed in vehicles of category M1 and N1.

##### 3.4.2.2.1.1 Vehicle based test

[RESS] installed in a vehicle that undergoes a vehicle crash test according to ECE-R12 Annex 3 or ECE-R 94 Annex 3 shall meet the acceptance criteria under 3.4.2.2.2.

Optionally, test described under 3.4.2.2.1.2 can be conducted with the mechanical load according to ECE-R12 Annex 3 or ECE-R94 Annex 3. The mechanical load shall be determined by the vehicle manufacturer using test or simulation data and agreed by the Technical Service.

[RESS] installed in a vehicle that undergoes a vehicle crash test according to ECE-R95 Annex 4 shall meet the acceptance criteria under 3.4.2.2.2.

Optionally, test described under 3.4.2.2.1.2 can be conducted with the mechanical load according to ECE-R95 Annex 4. The mechanical load shall be determined by the vehicle manufacturer using test or simulation data and agreed by the Technical Service.

The approval of the [RESS] tested under this condition is limited to the installation in the specific vehicle type.

##### 3.4.2.2.1.2 Component based test

Adjust the State of Charge (SOC) to a minimum of 50 % before starting the mechanical integrity test profile.

Crush a [RESS or pack(s)] between a resistance and a crush plate described in figure 7 with a force of [100 kN] in direction of travel and horizontally perpendicular to the direction of travel of the [RESS].

Figure 7:

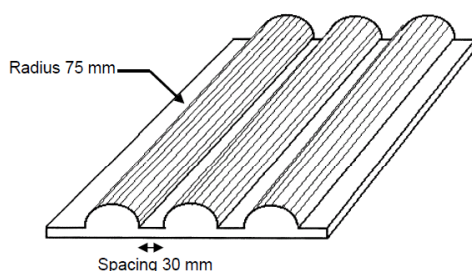

**Proposal how to structure the RESS safety requirements**

Status: 24.03.2011

Dimension of the crush plate:	600 x 600 mm
Orientation of the crush plate:	decision of battery manufacturer
Position of the crush plate:	shall cover the geometrical center of the crushed surface and the battery

**3.4.2.2.2 Acceptance criteria**

During the test, including [1] h after the test, the [battery system] shall exhibit no evidence

- a) of undefined visible venting
- b) battery enclosure rupture (no degradation of protection degree)
- c) fire
- d) explosion.

**3.4.2.3 Verification**

a) to d) of 3.4.1.2.2. shall be checked by visual inspection.



## Proposal how to structure the RESS safety requirements

Status: 24.03.2011

### **3.5 Fire Resistance**

#### **3.5.1 Rationale**

Simulates exposure of [RESS] to fire from the outside of the vehicle due to e.g. a fuel spill from a vehicle (either the vehicle itself or a nearby vehicle). This situation should leave the driver and passengers with enough time to evacuate and no explosion should occur in a later stage.

#### **3.5.2 Requirement**

The test is required for [RESS] to be placed at a level less than 1.5 m above ground. The test is carried out on one item as compared to R34 Annex 5 where 3 items are required.

##### **3.5.2.1 Conditions**

**3.5.2.1.1.** The state of charge (SOC) of [RESS] shall be at the maximum which is possible during normal vehicle operation. If for some reason another SOC would pose a higher risk then this SOC should be used.

**3.5.2.1.2.** The [RESS] shall have a temperature equal to the maximum allowed operating temperature before the test starts. If there is reason to believe that any other temperature would pose a higher risk than this temperature should be used.

**3.5.2.1.3.** The [RESS] shall be installed in a testing fixture simulating actual mounting conditions as far as possible; no combustible material should be used for this except the material that is part of the [RESS]. The method whereby the [RESS] is fixed in the fixture shall correspond to the relevant specifications for its installation. In the case of [RESS] designed for a specific vehicle use, vehicle parts which affect the course of the fire in any way shall be taken into consideration.

**3.5.2.1.4** The cooling system and the venting systems for prevention of overpressure shall remain operative during the test.

**3.5.2.1.5.** The flame to which the [RESS] is exposed shall be obtained by burning Heptanes in a pan. The quantity of Heptanes poured into the pan shall be sufficient to permit the flame, under free-burning conditions, to burn for the whole test procedure, i.e. at least 25 litres/m<sup>2</sup>. Water should be poured at the bottom of the pan to ensure a flat bottom of the pan. The pan dimensions shall be chosen so as to ensure that the sides of the [RESS] are exposed to the flame. The pan shall therefore exceed the horizontal projection of the [RESS] by at least 20 cm, but not more than 50 cm. The sidewalls of the pan shall not project more than 8 cm above the level of the Heptanes at the start of the test.

In cases when the [RESS] is distributed over the vehicle it is possible to run the test on each subpart of the [RESS].

**3.5.2.1.6.** The pan filled with Heptanes shall be placed under the [RESS] in such a way that the distance between the level of the Heptanes in the pan and the [RESS] bottom corresponds to the design height of the [RESS] above the road surface at

## Proposal how to structure the RESS safety requirements

Status: 24.03.2011

the unladen mass. Either the pan, or the testing fixture, or both, shall be freely movable.

**3.5.2.1.7.** During phase C of the test, the pan shall be covered by a screen placed 3 cm +/- 1 cm above the Heptanes level. The screen shall be made of a refractory material, as prescribed in [Annex 2]. There shall be no gap between the bricks and they shall be supported over the Heptanes pan in such a manner that the holes in the bricks are not obstructed. The length and width of the frame shall be 2 cm to 4 cm smaller than the interior dimensions of the pan so that a gap of 1 cm to 2 cm exists between the frame and the wall of the pan to allow ventilation. Before the test the screen shall be heated to 308 K +/- 5 K (35 degrees C +/- 5 degrees C). The firebricks may be wetted in order to guarantee the repeatable test conditions.

**3.5.2.1.8.** The tests should be carried out in an ambient temperature of at least 20 °C. If the tests are carried out in the open air, sufficient wind protection shall be provided and the wind velocity at pan level shall not exceed 2.5 km/h.

**3.5.2.1.9.** The test shall comprise of four phases ([see Appendix 1](#)).

### 3.5.2.1.7.1. Phase A: Pre-heating (Figure 1)

The Heptanes in the pan shall be ignited at a distance of at least 3 m from the [RESS] being tested. After 60 seconds pre-heating, the pan shall be placed under the [RESS]. If the size of the pan is too large to be moved without risking liquid spills etc. then the [RESS] and test rig can be moved instead of the pan.

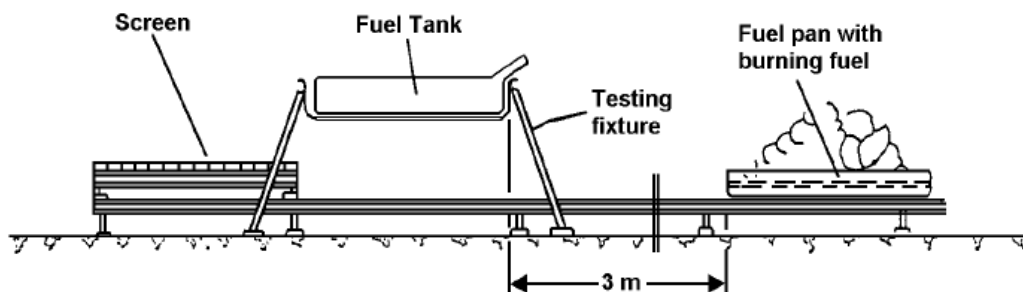

Figure 1

### 3.5.2.1.7.2. Phase B: Direct exposure to flame (Figure 2)

For 90 seconds the [RESS] shall be exposed to the flame from the freely burning Heptanes.

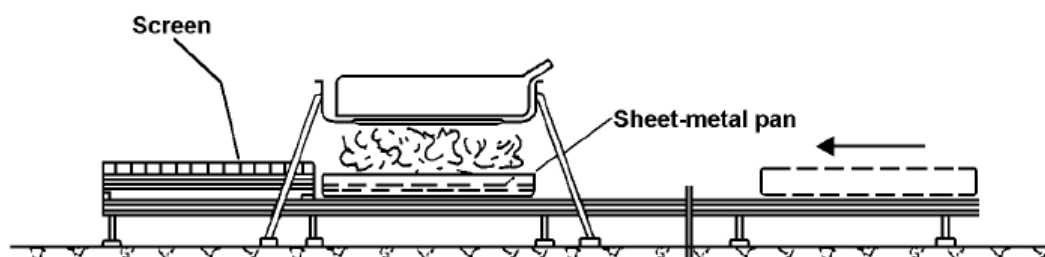

Figure 2

## Proposal how to structure the RESS safety requirements

Status: 24.03.2011

### 3.5.2.1.7.3. Phase C: Indirect exposure to flame (Figure 3)

As soon as phase B has been completed, the screen shall be placed between the burning pan and the [RESS]. The [RESS] shall be exposed to this reduced flame for a further 90 seconds.

Instead of conducting Phase C of the test, Phase B may be continued for additional 90 seconds at the manufacturer's discretion in those cases there is no reason to believe that this might pose a lower risk than the normal phase C.

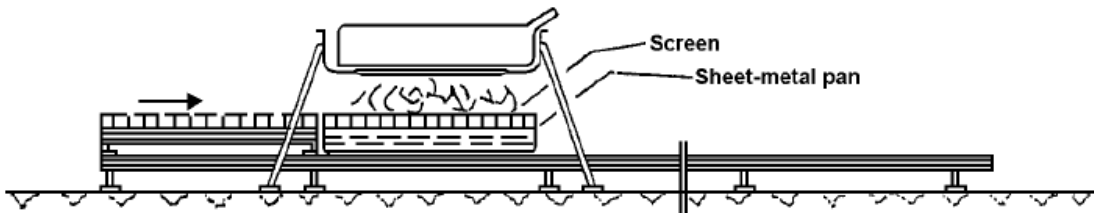

Figure 3

### 3.5.2.1.4. Phase D: End of test (Figure 4)

The burning pan covered with the screen shall be moved back to its original position (phase A). No extinguishing of the [RESS] shall be done. The [RESS] should be monitored for 1h after the removal of the pan.

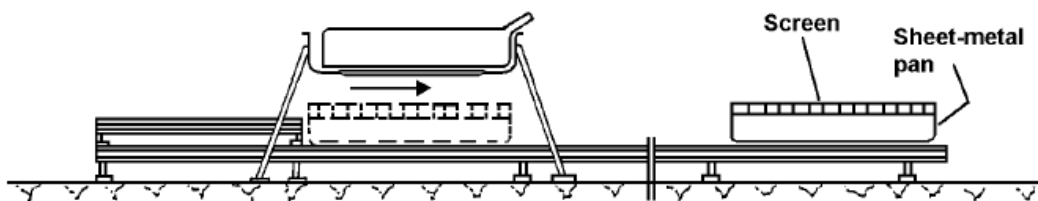

Figure 4

### 3.5.2.2 Acceptance criteria

During Phase A to D of the test, the [RESS] shall not explode or rupture and no venting shall occur during phase A-C.

### 3.5.3 Verification

The explosion criterion is verified by visual inspection. By no explosion means no sudden large increase in flames, no rapid release of energy, no pressure wave and no flying parts.

The venting criteria is evaluated either by signal from the BMS or if this is not possible by some other indication as agreed between the Technical Service and the manufacturer, this could be achieved by e.g. measuring gases produced during the test.

## Proposal how to structure the RESS safety requirements

Status: 24.03.2011

### 3.6 External Short Circuit

#### 3.6.1 Rationale

The purpose of the short circuit protection test it is to check the over-current protection function. This function shall interrupt the short circuit current in order to prevent the [RESS] from further related severe events caused by a short circuit current.

#### 3.6.2 Requirement

##### 3.6.2.1 Conditions

The [RESS] to be tested shall be temperature stabilized so that its external case temperature reaches minimum [23 °C] and then the [R ESS] shall be subjected to a short circuit condition with a total external resistance of less than 0.1 ohm at minimum [23°C]. This short circuit condition is continued for at least one hour after the [RESS] external case temperature has returned to minimum [23°C]. The [RESS] shall be observed for a further [six hours] for the test to be concluded.

[Direct after External Short Circuit a standard charging has to be conducted if not inhibited by the [RESS].] **Remark:** It has to be checked how such a requirement fits into the R 38.3 procedure.

##### 3.6.2.2 Acceptance criteria

During the test, including [1] h after the test, the [battery system] shall exhibit no evidence

- a) of undefined visible venting
- b) battery enclosure rupture (no degradation of protection degree)
- c) fire
- d) explosion
- e) leakage

For [RESS] using high voltage the isolation resistance measured at the end of the test shall maintain high voltage to ground isolation no less than 100 Ω/Volt.

#### 3.6.3 Verification

a) to d) of 3.6.2.2 shall be checked by visual inspection.

The isolation resistance shall be measured according to Annex 1.

## Proposal how to structure the RESS safety requirements

Status: 24.03.2011

### 3.7 Overcharge Protection (ISO 12405-1)

#### 3.7.1 Rationale

The purpose of the overcharge protection is to avoid severe events caused by an overcharging, for example it interrupts the current or voltage or limits it to an acceptable value.

#### 3.7.2 Requirement

##### 3.7.2.1 Conditions

The following requirements can be conducted with the [RESS] [or with module(s)] of the [RESS].

[If requirements are performed on [module basis], evidence shall be provided that the results are representative for [RESS].]

The [RESS] shall be at RT, fully charged and under normal operating conditions

**Remark:** Influence of no-cooling, switched-off cooling etc. has to be included AND to avoid safety requirements on cooling system from battery, depends on decision of vehicle or battery manufacturer

[Main contactors are closed if any; battery system is controlled by the BCU]

If it includes safety features to prevent overcharging, if BCU has no safety features, battery or module have to be safe "stand-alone"

**Remark:** If test on module level, there is no BCU or BCU has a special management function to prevent overcharging

The test shall be performed with all

**Remark:** Probably there are several passive protection devices

integrated passive protection devices operational. Active charge control of the test equipment shall be disconnected.

The normal charging of the application shall be described as multiple from 1C-Rate from cells. If cells with different C-Rates are used, the highest value shall be used.

The [RESS] shall be overcharged with at least two times C-Rate referring to normal charge mode of application

**Remark:** To respect different cell-types and charging mechanism

which is agreed by manufacturer and Technical Service

Charging shall be continued

- until the [RESS] (automatically) interrupt the charging or
- until the [RESS] is thermal stationary, which means the temperature change is lower than [2] K within [30] min

## Proposal how to structure the RESS safety requirements

Status: 24.03.2011

### 3.7.2.2 Acceptance criteria

During the test, including [1] h after the test, the battery system shall exhibit no evidence

- a) of undefined visible venting
- b) battery enclosure rupture (no degradation of protection degree)
- c) fire
- d) explosion.

For [RESS] using high voltage the isolation resistance measured at the end of the test shall maintain high voltage to ground isolation no less than 100  $\Omega$ /Volt.

[[1] after the test the [RESS] shall be re-used]

### 3.7.3 Verification

- a) to d) of 3.7.2.2 shall be checked by visible inspection after test
- b) Review of safety concept regarding ECE R13 H, Annex 8 or equal without test
- c) Analysis of measurement data and calculation

The isolation resistance shall be measured according to Annex 1.

## Proposal how to structure the RESS safety requirements

Status: 24.03.2011

### 3.8 Over-discharge Protection

#### 3.8.1 Rationale

The purpose of the over-discharge protection test it is to check the functionality of the over-discharge protection function. This device shall interrupt the over-discharge current in order to prevent the Device under Test (DUT) from any further related severe events caused by an over-discharge current.

#### 3.8.2 Requirement

##### 3.8.2.1 Conditions

[For [RESS] which do not need an over-discharge protection the manufacturer shall demonstrate to provide evidence to the Technical Service which shows that any over-discharge and standard charge afterwards does not lead to any situation described in the acceptance criteria.]

For [RESS] which need an over-discharge protection the following test shall be conducted with the [RESS] [or with [module(s)] of the RESS].

[If tests are performed on [module basis], evidence shall be provided that the results are representative for [RESS].]

The [RESS] shall be at room temperature (RT), charged as under normal operating conditions with the cooling system operating (main contactors are closed if any, battery system are controlled by the [battery control unit (BCU)]). The test shall be performed with integrated passive circuit protection devices operational. Active discharge control of the test equipment shall be disconnected.

Perform a standard discharge. When reaching the normal discharge limits, discharging with 1C rate shall be continued.

Discharging shall be continued until the [RESS] interrupt the discharging automatically.

Direct after the over-discharging a standard charging has to be conducted if not inhibited by the system.

##### 3.8.2.2 Acceptance criteria

During the test, including [1] h after the test, the [battery system] shall exhibit no evidence

- a) of undefined visible venting
- b) battery enclosure rupture (no degradation of protection degree)
- c) fire
- d) explosion.

For [RESS] using high voltage the isolation resistance measured at the end of the test shall maintain high voltage to ground isolation no less than 100  $\Omega$ /Volt.

#### 3.8.3 Verification

[a) to d) of 3.8.2.2 shall be checked by visual inspection.]

The isolation resistance shall be measured according to Annex 1.

## Proposal how to structure the RESS safety requirements

Status: 24.03.2011

### **3.9 Over-temperature Protection**

#### **3.9.1 Rationale**

Verify the functionality that prevents the operation at over-temperatures inside the [RESS]

#### **3.9.2 Requirement**

When the maximum working temperature of the [RESS], specified by the manufacturer, is exceeded, the [RESS] high voltage buses shall be opened [or the battery cannot be operated] at the latest [5 min] after this temperature is reached. After the test, the components shall be functional.

##### **3.9.2.1 Conditions**

The [RESS] shall be at any state of charge, which allows the normal operation of the power train as recommended by the manufacturer.

The [RESS] shall be placed in a convective oven or climatic chamber (hereby called over-temperature room). The over-temperature room temperature shall be increased at a rate of  $5\text{ °C/min} \pm 2\text{ °C/min}$  until it reaches the maximum working temperature of the [RESS], specified by the manufacturer  $+ 20\text{ °C}$ . The [RESS] temperature shall be monitored by the measurement devices which are integrated inside the [RESS] by the manufacturer. The manufacturer shall provide the technical service with the relevant technical information dossier of the measurement device. The content of this information dossier shall be provided by the technical service.

The test shall be interrupted when the requirement is satisfied or when the [RESS] reaches or exceeds the maximum working temperature specified by the manufacturer for more than 5 min without satisfying the requirement.

##### **3.9.2.2 Acceptance criteria**

The [RESS] complies with the requirement when the signal related to the physical opening sent by the BMS is detected.

#### **3.9.3 Verification**

The internal temperature and the signal related to the opening of the high voltage buses of the [RESS] are monitored. In order to verify the functionality of the components, the [RESS] shall rest until it reaches the ambient temperature ( $25\text{ °C} \pm 5\text{ °C}$ ). A charge/discharge cycle shall be applied to the [RESS]. The charge and discharge shall be functional.



## Proposal how to structure the RESS safety requirements

Status: 24.03.2011

### 3.10 Protection against direct contact (related to R100)

#### 3.10.1 Rationale

Verify the functionality that protects persons to come in contact with high voltage live parts (only for [RESS] above 60 VDC). This requirement has to be proved under ECE R100.

## Proposal how to structure the RESS safety requirements

Status: 24.03.2011

### 3.11 Emission

#### 3.11.1 Rationale

Possible emission of gases caused by the energy conversion process during normal use shall be considered.

#### 3.11.2 Requirement

Open type traction batteries shall meet the requirements of ECE R100 according to hydrogen emissions.

Systems with a closed chemical process are considered as emission-free under normal operation (e.g. Li-ion).

Other technologies shall be evaluated by the manufacturer and the Technical Service according possible emissions under normal operation.

##### 3.11.2.1 Conditions

##### 3.11.2.2 Acceptance criteria

For hydrogen emissions see ECE R100.

Systems with closed chemical process are emission-free and no verification is necessary.

#### 3.11.3 Verification

For hydrogen emissions see ECE R100.

The closed chemical process has to be described by the manufacturer.

# Proposal how to structure the RESS safety requirements

Status: 24.03.2011

## ANNEX 1: MEASUREMENT OF ISOLATION RESISTANCE

### 1. Measurement method

The isolation resistance measurement shall be conducted by selecting an appropriate measurement method from among those listed in Paragraphs 1.1. through 1.2., depending on the electrical charge of the live parts or the isolation resistance, etc.

The range of the electrical circuit to be measured shall be clarified in advance, using electrical circuit diagrams, etc.

Moreover, modification necessary for measuring the isolation resistance may be carried out, such as removal of the cover in order to reach the live parts, drawing of measurement lines, change in software, etc.

In cases where the measured values are not stable due to the operation of the on-board isolation resistance monitoring system, etc., necessary modification for conducting the measurement may be carried out, such as stopping of the operation of the device concerned or removing it. Furthermore, when the device is removed, it shall be proven, using drawings, etc., that it will not change the isolation resistance between the live parts and the electrical chassis.

Utmost care shall be exercised as to short circuit, electric shock, etc., for this confirmation might require direct operations of the high-voltage circuit.

#### 1.1. Measurement method using DC voltage from off-vehicle sources

##### 1.1.1. Measurement instrument

An isolation resistance test instrument capable of applying a DC voltage higher than the working voltage of the high voltage bus shall be used.

##### 1.1.2. Measurement method

An insulator resistance test instrument shall be connected between the live parts and the electrical chassis. Then, the isolation resistance shall be measured by applying a DC voltage at least half of the working voltage of the high voltage bus.

If the system has several voltage ranges (e.g. because of boost converter) in galvanically connected circuit and some of the components cannot withstand the working voltage of the entire circuit, the isolation resistance between those components and the electrical chassis can be measured separately by applying at least half of their own working voltage with those component disconnected.

## Proposal how to structure the RESS safety requirements

Status: 24.03.2011

1.2. Measurement method using the vehicle's own [RESS] as DC voltage source

1.2.1. Test vehicle conditions

The high voltage-bus shall be energized by the vehicle's own [RESS] and/or energy conversion system and the voltage level of the [RESS] and/or energy conversion system throughout the test shall be at least the nominal operating voltage as specified by the vehicle manufacturer.

1.2.2. Measurement instrument

The voltmeter used in this test shall measure DC values and shall have an internal resistance of at least 10 M $\Omega$ .

1.2.3. Measurement method

1.2.3.1. First step

The voltage is measured as shown in Figure 1 and the high voltage Bus voltage ( $V_b$ ) is recorded.  $V_b$  shall be equal to or greater than the nominal operating voltage of the [RESS] and/or energy conversion system as specified by the vehicle manufacturer.

Figure 1 - Measurement of  $V_b$ ,  $V_1$ ,  $V_2$

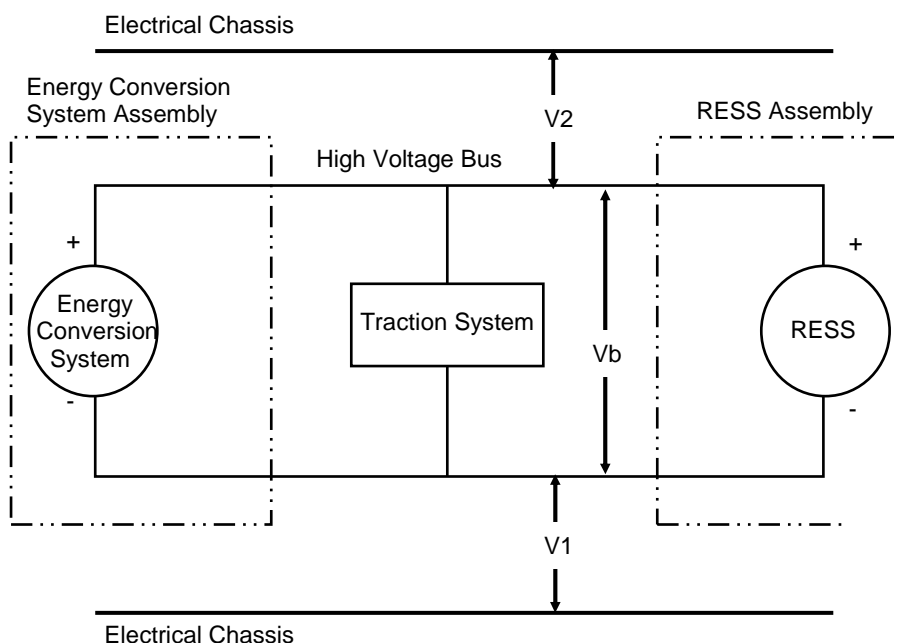

## Proposal how to structure the RESS safety requirements

Status: 24.03.2011

### 1.2.3.2. Second step

Measure and record the voltage ( $V_1$ ) between the negative side of the high voltage bus and the electrical chassis (see Figure 1).

### 1.2.3.3. Third step

Measure and record the voltage ( $V_2$ ) between the positive side of the high voltage bus and the electrical chassis (see Figure 1).

### 1.2.3.4. Fourth step

If  $V_1$  is greater than or equal to  $V_2$ , insert a standard known resistance ( $R_o$ ) between the negative side of the high voltage bus and the electrical chassis. With  $R_o$  installed, measure the voltage ( $V_1'$ ) between the negative side of the high voltage bus and the electrical chassis (see Figure 2).

Calculate the electrical isolation ( $R_i$ ) according to the following formula:

$$R_i = R_o \cdot (V_b / V_1' - V_b / V_1) \quad \text{or} \quad R_i = R_o \cdot V_b \cdot (1 / V_1' - 1 / V_1)$$

Figure 2 - Measurement of  $V_1'$

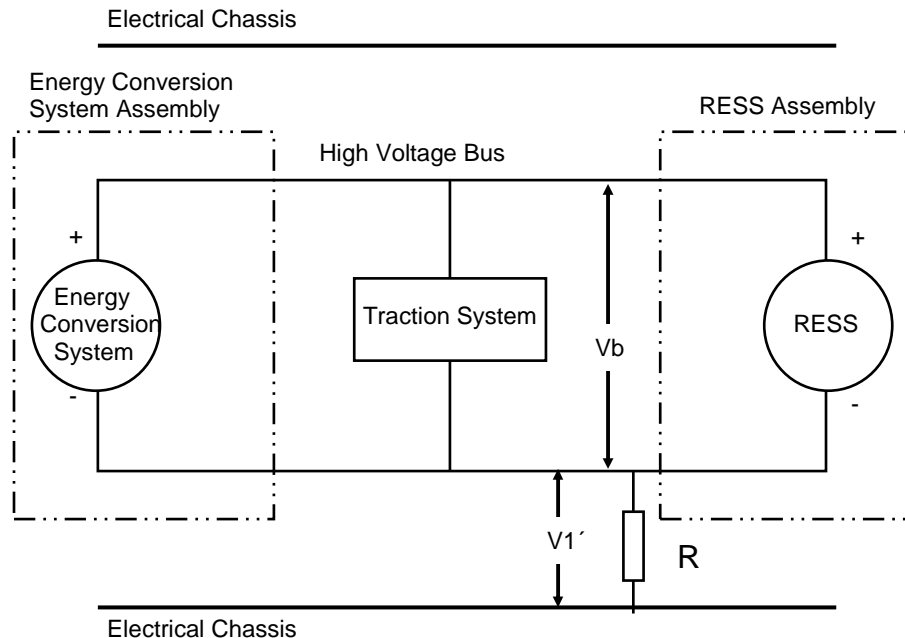

If  $V_2$  is greater than  $V_1$ , insert a standard known resistance ( $R_o$ ) between the positive side of the high voltage bus and the electrical chassis. With  $R_o$  installed, measure the voltage ( $V_2'$ ) between the positive side of the high voltage bus and the electrical chassis. (See Figure 3). Calculate the electrical isolation ( $R_i$ ) according to the formula

## Proposal how to structure the RESS safety requirements

Status: 24.03.2011

shown. Divide this electrical isolation value (in  $\Omega$ ) by the nominal operating voltage of the high voltage bus (in volts).

Calculate the electrical isolation ( $R_i$ ) according to the following formula:

$$R_i = R_o \cdot (V_b/V_2' - V_b/V_2) \quad \text{or} \quad R_i = R_o \cdot V_b \cdot (1/V_2' - 1/V_2)$$

Figure 3 - Measurement of  $V_2'$

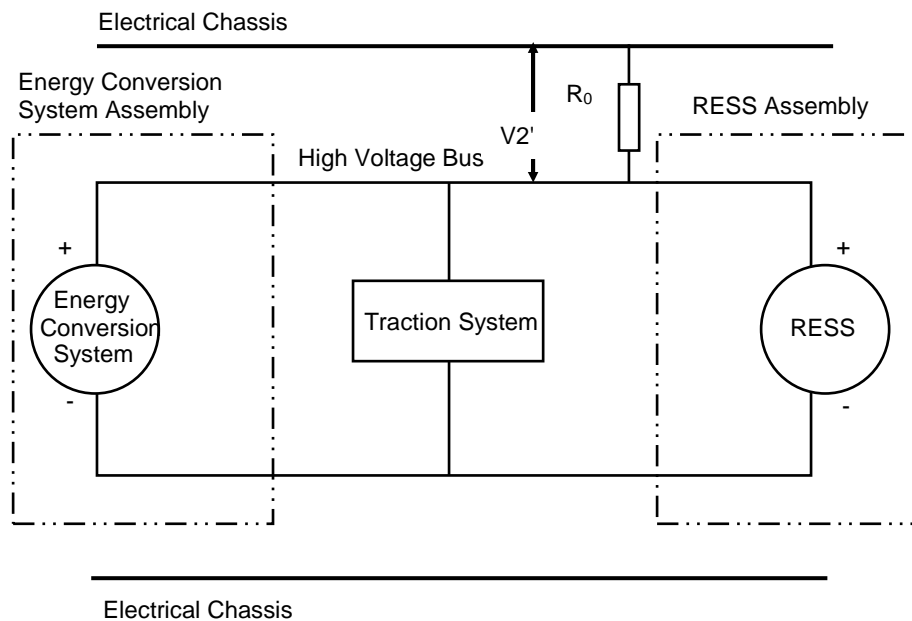

### 1.2.3.5. Fifth step

The electrical isolation value  $R_i$  (in  $\Omega$ ) divided by the working voltage of the high voltage bus (in volts) results in the isolation resistance (in  $\Omega/V$ ).

NOTE 1: The standard known resistance  $R_o$  (in  $\Omega$ ) should be the value of the minimum required isolation resistance (in  $\Omega/V$ ) multiplied by the working voltage of the vehicle plus/minus 20 per cent (in volts).  $R_o$  is not required to be precisely this value since the equations are valid for any  $R_o$ ; however, a  $R_o$  value in this range should provide good resolution for the voltage measurements.

# Proposal how to structure the RESS safety requirements

Status: 24.03.2011

## ANNEX 2: DIMENSIONS AND TECHNICAL DATA OF FIREBRICKS

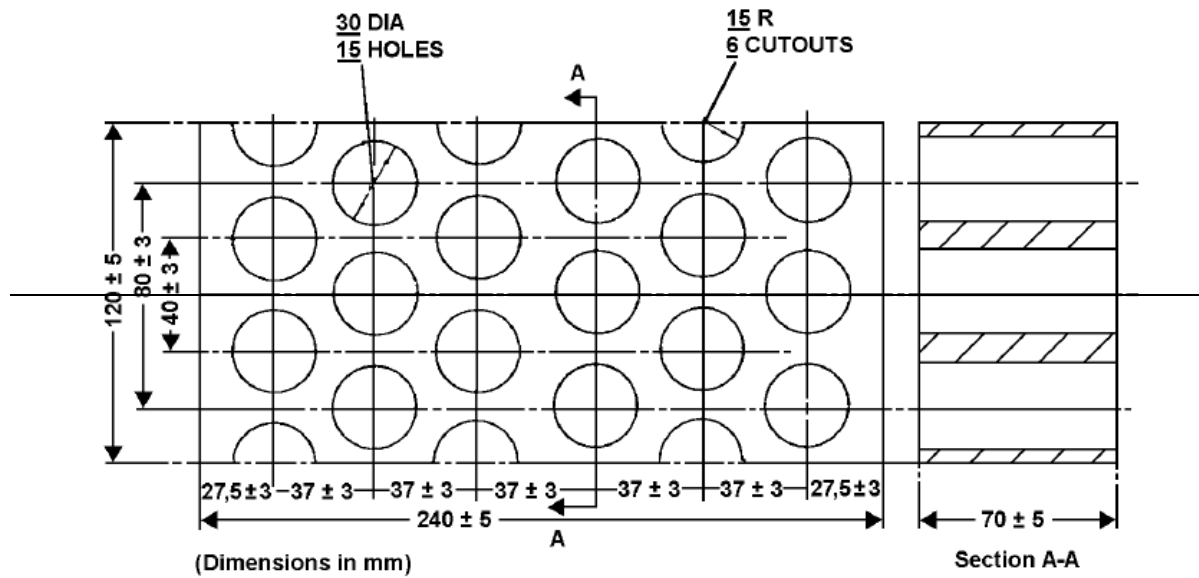

Fire resistance	(Seger-Kegel) SK 30
Al <sub>2</sub> O <sub>3</sub> content	30 - 33 per cent
Open porosity (P <sub>o</sub> )	20 - 22 per cent vol.
Density	1,900 - 2,000 kg/m <sup>3</sup>
Effective holed area	44.18 per cent

**Proposal how to structure the RESS safety requirements**

Status: 24.03.2011

**B) ADDITIONAL REQUIREMENTS?****IMMERSION TEST (RESS COMPLETE UNDER WATER)**

Rationale for the necessity maybe by NL.

Flooded roads are common in other areas also. A test is specified in SAE J2464.

REMARK: Immersion will not cause any safety critical phenomena for RESS.

**Remark from Korea:**

§ Additional Requirement: Immersion Test

In the past decade, we witnessed many floods around the world. The **Hurricane Katrina** in 2005 has left huge flood damage to the southern part of USA. The Queensland in Australia also was flooded as recently as January this year. The centre of Seoul, Korea, was flooded to the waist deep in Sep, 2010.

An immersion test should be included. The sea water, as fluid, may be appropriate. The electrical safety as well as chemical safety (for example, toxicity) should be secured.

**[DUST]**

**MARKING**

ISO 6469-3 and R100

**EMC**

R10

**Tell-tale**