

Distr.  
GENERAL

TRANS/WP.29/GRSG/2000/14/Add.1  
28 September 2000

ENGLISH ONLY

ECONOMIC COMMISSION FOR EUROPE

INLAND TRANSPORT COMMITTEE

World Forum for Harmonization of Vehicle Regulations (WP.29)

Working Party on General Safety Provisions (GRSG)

(Seventy-ninth session, 16-20 October 2000,  
agenda item 4.)

**PROPOSAL FOR A DRAFT CORRIGENDUM TO REGULATION No. 66  
(Strength of superstructure)**

Transmitted by the Expert from the Czech Republic

Note: The text reproduced below was prepared by the expert from the Czech Republic in order to update his proposal. The proposed amendments refer to document TRANS/WP.29/GRSG/2000/14.

---

Note: This document is distributed to the Experts on General Safety Provisions only.

GE.00-

Paragraph 1, amend to read (including the corresponding footnote \*/):

"1 SCOPE:

This Regulation applies to single-deck vehicles of category M3\*/."

\*/ As defined in annex 7 to the Consolidated Resolution on the Construction of Vehicles (R.E.3)(document TRANS/WP.29/78/Rev.1/Amend.2)."

Paragraph 7.2.(former), renumber as paragraph 7.1., amend the word "R" to read "R<sub>B</sub>" (two times), and amend to read:

" .... of the vehicle side-wall. The point of these two which defines the widest residual space, shall be taken as decisive for its size in form of a trapezoid of 750 mm height (take - 100 mm for its upper corner, and + 150 mm for its lower corner), see figure 1(a)."

Paragraph 7.1. (former), renumber as paragraph 7.2., amend the word "R" to read "R<sub>B</sub>" (five times), and delete the square brackets marking the value of 300 mm.

Figures 1(a) and 1(b), amend to read:

"Figure 1

RESIDUAL SPACE

(All dimensions in millimetres)

1 (a) LATERALLY

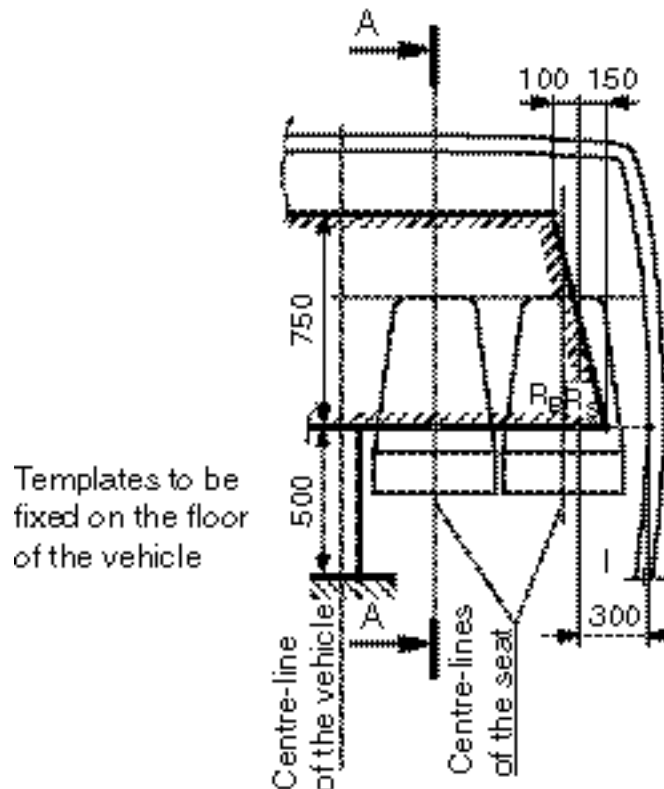

1 (b) LONGITUDINALLY Section A-A of the vehicle in the vertical plane of the centre-line of the inboard seat.

