

30 September 2009

AGREEMENT

**CONCERNING THE ADOPTION OF UNIFORM TECHNICAL PRESCRIPTIONS
FOR WHEELED VEHICLES, EQUIPMENT AND PARTS WHICH CAN BE FITTED
AND/OR BE USED ON WHEELED VEHICLES AND THE CONDITIONS FOR
RECIPROCAL RECOGNITION OF APPROVALS GRANTED ON THE BASIS OF
THESE PRESCRIPTIONS */**

(Revision 2, including the amendments which entered into force on 16 October 1995)

Addendum 110: Regulation No. 111

Erratum

**UNIFORM PROVISIONS CONCERNING THE APPROVAL OF TANK VEHICLES
OF CATEGORIES N AND O WITH REGARD TO ROLLOVER STABILITY**



UNITED NATIONS

*/ Former title of the Agreement:

Agreement Concerning the Adoption of Uniform Conditions of Approval and Reciprocal Recognition of Approval for Motor Vehicle Equipment and Parts, done at Geneva on 20 March 1958.

GE-09

Annexe 4

Figure 1, correct to read:

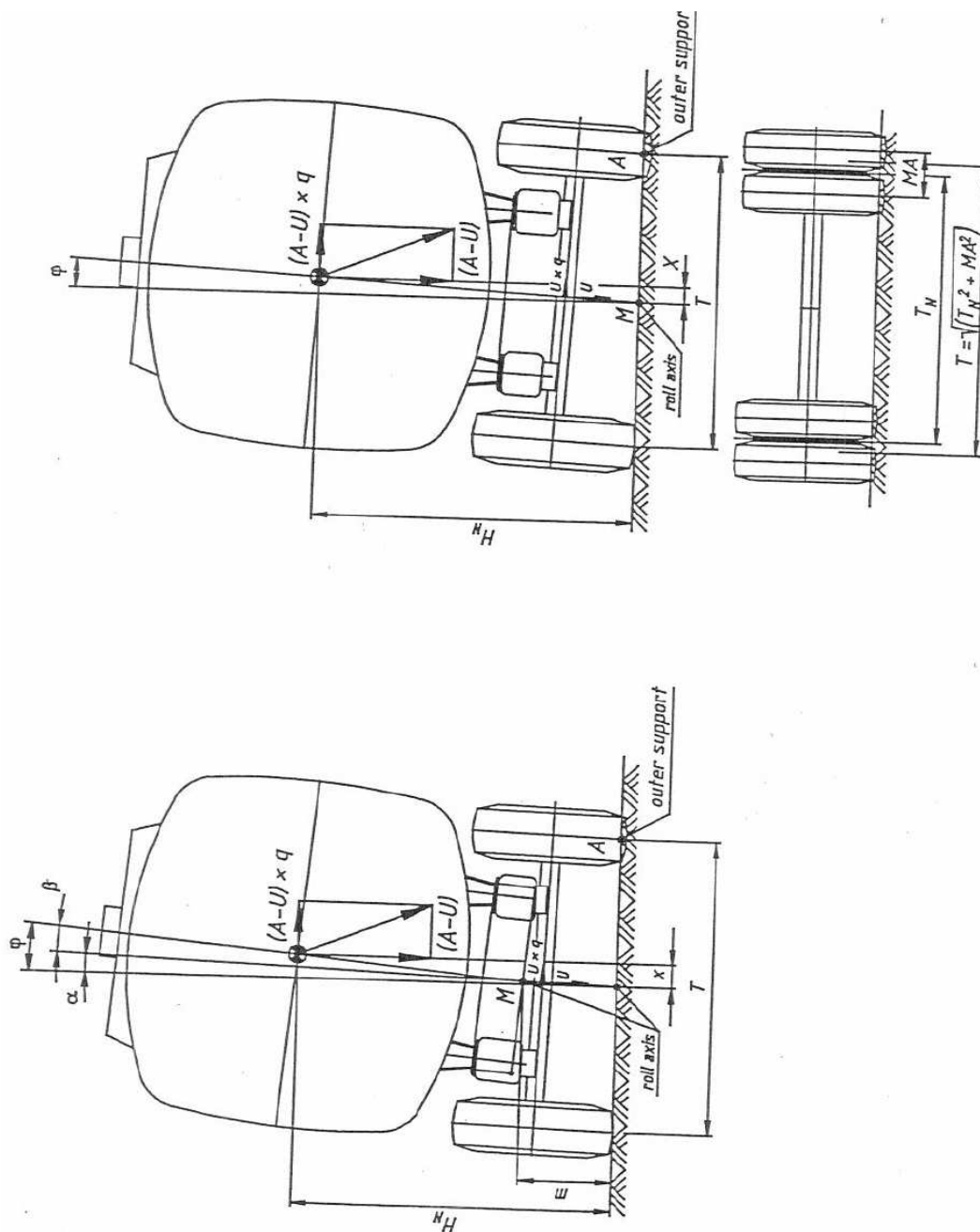

Figure 1: Cross-section of a tank vehicle
