

29 September 2009

## **AGREEMENT**

### **CONCERNING THE ADOPTION OF UNIFORM TECHNICAL PRESCRIPTIONS FOR WHEELED VEHICLES, EQUIPMENT AND PARTS WHICH CAN BE FITTED AND/OR BE USED ON WHEELED VEHICLES AND THE CONDITIONS FOR RECIPROCAL RECOGNITION OF APPROVALS GRANTED ON THE BASIS OF THESE PRESCRIPTIONS \*/**

(Revision 2, including the amendments which entered into force on 16 October 1995)

---

#### **Addendum 73: Regulation No. 74**

#### **Revision 2**

#### **Incorporating all valid text up to:**

Supplement 2 to the 01 series of amendments - Date of entry into force: 12 September 2001

Supplement 3 to the 01 series of amendments - Date of entry into force: 5 December 2001

Corrigendum 1 to Supplement 2 to the 01 series of amendments - Date of entry into force:  
25 June 2003

Supplement 4 to the 01 series of amendments - Date of entry into force: 2 February 2007

Supplement 5 to the 01 series of amendments - Date of entry into force: 15 October 2008

Supplement 6 to the 01 series of amendments - Date of entry into force: 22 July 2009

### **UNIFORM PROVISIONS CONCERNING THE APPROVAL OF CATEGORY L1 VEHICLES WITH REGARD TO THE INSTALLATION OF LIGHTING AND LIGHT- SIGNALLING DEVICES**



**UNITED NATIONS**

---

\*/ Former title of the Agreement:

Agreement Concerning the Adoption of Uniform Conditions of Approval and Reciprocal Recognition of Approval for Motor Vehicle Equipment and Parts, done at Geneva on 20 March 1958.

GE.09-24706



Regulation No. 74

UNIFORM PROVISIONS CONCERNING THE APPROVAL OF CATEGORY L<sub>1</sub> VEHICLES  
WITH REGARD TO THE INSTALLATION OF LIGHTING AND LIGHT-SIGNALLING  
DEVICES

CONTENTS

REGULATION	<u>Page</u>
1. Scope .....	5
2. Definitions .....	5
3. Application for approval.....	9
4. Approval .....	10
5. General specifications.....	12
6. Individual specifications.....	16
7. Registration of vehicles .....	27
8. Conformity of production.....	27
9. Penalties for non-conformity of production .....	28
10. Modification and extension of approval of a vehicle type with regard to the installation of lighting and light-signalling devices .....	28
11. Production definitely discontinued.....	28
12. Transitional provisions .....	29
13. Names and addresses of Technical Services responsible for conducting approval tests, and of Administrative Departments.....	29

CONTENTS (continued)

ANNEXES

- Annex 1 - Communication concerning the approval or extension or refusal or withdrawal of approval or production definitely discontinued of a vehicle type (moped) with regard to the installation of lighting and light-signalling devices, pursuant to Regulation No. 74
- Annex 2 - Arrangements of approval marks
- Annex 3 - Lamp surfaces, axis and centre of reference, and angles of geometric visibility
- Annex 4 - Forward visibility of red lights and rearward visibility of white lights
- Annex 5 - Control of conformity of production

1. SCOPE

This Regulation applies to vehicles of category L<sub>1</sub> 1/ with regard to the installation of lighting and light-signalling devices.

2. DEFINITIONS

For the purpose of this Regulation,

- 2.1. "Approval of a vehicle" means the approval of a vehicle type with regard to the number and mode of installation of the lighting and light-signalling devices;
- 2.2. "Vehicle type" means a category of power-driven vehicles which do not differ from each other in such essential respects as:
- 2.2.1. the dimensions and external shape of the vehicle;
- 2.2.2. the number and position of the devices;
- 2.2.3. the following shall likewise not be deemed to be "vehicles of a different type":
- 2.2.3.1. vehicles which differ within the meaning of paragraphs 2.2.1. and 2.2.2. above but not in such a way as to entail a change in the kind, number, position and geometric visibility of the lamps prescribed for the vehicle type in question;
- 2.2.3.2. vehicles on which lamps approved under one of the Regulations annexed to the 1958 Agreement, or lamps allowed in the country in which the vehicles are registered, are fitted, or are absent where their fitting is optional;
- 2.3. "transverse plane" means a vertical plane perpendicular to the median longitudinal plane of the vehicle;
- 2.4. "unladen vehicle" means a vehicle without a driver, or passenger, and unladen, but with its fuel tank full and its normal complement of tools;
- 2.5. "lamp" means a device designed to illuminate the road or to emit a light signal to other road users. Rear registration plate lamp and retro-reflectors are likewise to be regarded as lamps;
- 2.5.1. "Equivalent lamps" means lamps having the same function and authorised in the country in which the vehicle is registered; such lamps may have different

---

1/ As defined in Annex 7 to the Consolidated Resolution on the Construction of Vehicles (R.E.3), (document TRANS/WP.29/78/Rev.1/Amend.2 as last amended by Amend.4).

characteristics from those of the lamps with which the vehicle is equipped at the time of approval, on condition that they satisfy the requirements of this Regulation;

- 2.5.2. "Independent lamps" means devices having separate illuminating surfaces, separate light sources and separate lamp bodies;
- 2.5.3. "Grouped lamps" means devices having separate illuminating surfaces and separate light sources, but a common lamp body;
- 2.5.4. "Combined" means devices having separate illuminating surfaces, but a common light source and a common lamp body;
- 2.5.5. "Reciprocally incorporated" means devices having separate light sources or a single light source operating under different conditions (for example, optical, mechanical, electrical differences), totally or partially common illuminating surfaces and a common lamp body;
- 2.5.6. "Driving beam (main-beam) headlamp" means the lamp used to illuminate the road over a long distance ahead of the vehicle;
- 2.5.7. "Passing beam (dipped-beam) headlamp" means the lamp used to illuminate the road ahead of the vehicle without dazzling or causing undue discomfort to oncoming drivers and other road users;
- 2.5.8. "Front position lamp" means the lamp used to indicate the presence of the vehicle when viewed from the front;
- 2.5.9. "Retro-reflector" means a device used to indicate the presence of a vehicle by the reflection of light emanating from a light source not connected to the vehicle, the observer being situated near the source;  
For the purpose of this Regulation, retro-reflecting number plates are not considered as retro-reflectors;
- 2.5.10. "Direction-indicator lamp" means the lamp used to indicate to other road-users that the driver intends to change direction to the right or to the left;  
A direction-indicator lamp or lamps may also be used according to provisions of Regulation No. 97.
- 2.5.11. "Stop lamp" means the lamp used to indicate to other road-users to the rear of the vehicle that its driver is applying the service brake;
- 2.5.12. "Rear position lamp" means the lamp used to indicate the presence of the vehicle when viewed from the rear;

- 2.5.13. "Rear-registration-plate illuminating device" means the device used to illuminate the space reserved for the rear registration plate; such a device may consist of several optical component.
- 2.6. "Light-emitting surface" of a "lighting device", "light-signalling device" or a retro-reflector means all or part of the exterior surface of the transparent material as declared in the request for approval by the manufacturer of the device on the drawing, see Annex 3;
- 2.7. "Illuminating surface" (see Annex 3);
- 2.7.1. "Illuminating surface of a lighting device" (paragraphs 2.5.6. and 2.5.7.) means the orthogonal projection of the full aperture of the reflector, or in the case of headlamps with an ellipsoidal reflector of the "projection lens", on a transverse plane. If the lighting device has no reflector, the definition of paragraph 2.7.2. shall be applied. If the light emitting surface of the lamp extends over part only of the full aperture of the reflector, then the projection of that part only is taken into account.
- In the case of a passing beam headlamp, the illuminating surface is limited by the apparent trace of the cut-off on to the lens. If the reflector and lens are adjustable relative to one another, the mean adjustment should be used;
- 2.7.2. "Illuminating surface of a light-signalling device other than a retro-reflector" (paragraphs 2.5.8., 2.5.10., 2.5.11. and 2.5.12.) means the orthogonal projection of the lamp in a plane perpendicular to its axis of reference and in contact with the exterior light-emitting surface of the lamp, this projection being bounded by the edges of screens situated in this plane, each allowing only 98 per cent of the total luminous intensity of the light to persist in the direction of the axis of reference. To determine the lower, upper and lateral limits of the illuminating surface, only screens with horizontal or vertical edges shall be used;
- 2.7.3. "Illuminating surface of a retro-reflector" (paragraph 2.5.9.) means the orthogonal projection of a retro-reflector in a plane perpendicular to its axis of reference and delimited by planes continuous to the outermost parts of the retro-reflector's optical system and parallel to that axis. For the purposes of determining the lower, upper and lateral edges of the device, only horizontal and vertical planes shall be considered;
- 2.8. The "apparent surface" for a defined direction of observation means, at the request of the manufacturer or his duly accredited representative, the orthogonal projection of: either the boundary of the illuminating surface projected on the exterior surface of the lens (a-b),  
or the light-emitting surface (c-d),  
in a plane perpendicular to the direction of observation and tangential to the most exterior point of the lens (see Annex 3 to this Regulation);

- 2.9. "Axis of reference" (or "reference axis") means the characteristic axis of the lamp determined by the manufacturer (of the lamp) for use as the direction of reference ( $H = 0^\circ$ ,  $V = 0^\circ$ ) for angles of field for photometric measurements and for installing the lamp on the vehicle;
- 2.10. "Centre of reference" means the intersection of the axis of reference with the exterior light-emitting surface; it is specified by the manufacturer of the lamp;
- 2.11. "Angles of geometric visibility" means the angles which determine the field of the minimum solid angle in which the apparent surface of the lamp must be visible. That field of the solid angle is determined by the segments of the sphere of which the centre coincides with the centre of reference of the lamp and the equator is parallel with the ground. These segments are determined in relation to the axis of reference. The horizontal angles  $\beta$ , correspond to the longitude and the vertical angles  $\alpha$  to the latitude. There must be no obstacle on the inside of the angles of geometric visibility to the propagation of light from any part of the apparent surface of the lamp observed from infinity. If measurements are taken closer to the lamp, the direction of observation must be shifted parallel to achieve the same accuracy. On the inside of the angles of geometric visibility no account is taken of obstacles, if they were already presented when the lamp was type approved.
- If, when the lamp is installed, any part of the apparent surface of the lamp is hidden by any further parts of the vehicle, proof shall be furnished that the part of the lamp not hidden by obstacles still conforms to the photometric values prescribed for the approval of the device as an optical unit (see Annex 3 of this Regulation). Nevertheless, when the vertical angle of geometric visibility below the horizontal may be reduced to  $5^\circ$  (lamp at less than 750 mm above the ground) the photometric field of measurements of the installed optical unit may be reduced to  $5^\circ$  below the horizontal.
- 2.12. "Extreme outer edge", on either side of the vehicle means the plane parallel to the median longitudinal plane of the vehicle and tangent to the latter's lateral outer edge, disregarding rear-view mirrors, direction indicators, position lamps and retro-reflectors;
- 2.13. "Over-all width" means the distance between the two vertical planes defined in paragraph 2.12. above;
- 2.14. "A single lamp" means a device or part of a device, having one function and one apparent surface in the direction of the reference axis (see paragraph 2.8. of this Regulation) and one or more light sources.  
For the purpose of installation on a vehicle, a "single lamp" also means any assembly of two independent or grouped lamps, whether identical or not, having the same function, if they are installed so that the projection of their apparent surfaces in the



direction of the reference axis occupies not less than 60 per cent of the smallest rectangle circumscribing the projections of the said apparent surfaces in the direction of the reference axis. In such a case, each of these lamps shall, where approval is required, be approved as a type "D" lamp. This possible combination does not apply to driving beam headlamps and passing beam headlamps.

- 2.15. "Distance between two lamps" which face in the same direction means the shortest distance between the two apparent surfaces in the direction of the reference axis. Where the distance between the lamps clearly meets the requirements of the Regulation, the exact edges of apparent surfaces need not be determined;
- 2.16. "Operating tell-tale" means a visual or auditory signal (or any equivalent signal) indicating that a device has been switched on and whether or not it is operating correctly;
- 2.17. "Circuit-closed tell-tale" means a visual (or any equivalent signal) indicating that a device has been switched on, but not indicating whether or not it is operating correctly;
- 2.18. "Optional lamp" means a lamp, the installation of which is left to the discretion of the manufacturer;
- 2.19. "Ground" means the surface on which the vehicle stands which should be substantially horizontal;
- 2.20. "Device" means a component or combination of components used in order to perform one or several functions.
- 2.21. "Colour of the light emitted from the device". The definitions of the colour of the light emitted given in Regulation No. 48 and its series of amendments in force at the time of application for type approval shall apply to this Regulation.

### 3. APPLICATION FOR APPROVAL

- 3.1. The application for approval of a vehicle type with regard to the installation of its lighting and light-signalling devices shall be submitted by the vehicle manufacturer or by his duly accredited representative.
- 3.2. It shall be accompanied by the following documents and particulars, in triplicate:
- 3.2.1. a description of the vehicle type with regard to the items mentioned in paragraphs 2.2.1. and 2.2.2. above; the vehicle type shall be specified;

- 3.2.2. a list of the devices intended by the manufacturer to form the lighting and light-signalling equipment: the list may include several types of device for each function; each type shall be duly identified (national or international approval mark, if approved, name of manufacturer, etc.); in addition, the list may include in respect of each function the additional annotation "or equivalent devices";
- 3.2.3. a layout drawing of the lighting and light-signalling installation as a whole, showing the position of the various devices on the vehicle;
- 3.2.4. if necessary, in order to verify the conformity to the prescriptions of the present Regulation, a layout drawing or drawings of each lamp showing the illuminating surface, as defined in paragraph 2.7.1. above, the light-emitting surface as defined in paragraph 2.6., the axis of reference as defined in paragraph 2.9. and the centre of reference as defined in paragraph 2.10. This information is not necessary in the case of the rear registration plate lamp (paragraph 2.5.13.).
- 3.2.5. The application shall include a statement of the method used for the definition of the apparent surface (paragraph 2.8.)
- 3.3. An unladen vehicle fitted with a complete set of lighting and light-signalling equipment, as prescribed in paragraph 3.2.2. above, and representative of the vehicle type to be approved shall be submitted to the Technical Service responsible for conducting approval tests.
4. APPROVAL
- 4.1. If the vehicle type submitted for approval pursuant to this Regulation meets the requirements of the Regulation in respect of all the devices specified in the list, approval of that vehicle type shall be granted.
- 4.2. An approval number shall be assigned to each type approved. Its first two digits (at present 01 for the Regulation in its 01 series of amendments) shall indicate the series of amendments incorporating the most recent major technical amendments made to the Regulation at the time of issue of the approval. The same Contracting Party shall not assign this number to another vehicle type or to the same vehicle type submitted with equipment not specified in the list referred to in paragraph 3.2.2. above, subject to the provisions of paragraph 7. of this Regulation.
- 4.3. Notice of approval or of extension or refusal of approval or of production definitely discontinued of a vehicle type pursuant to this Regulation shall be communicated to the Parties to the Agreement applying this Regulation, by means of a form conforming to the model in Annex 1 to this Regulation.

- 4.4. There shall be affixed, conspicuously and in a readily accessible place specified on the approval form, to every vehicle conforming to a vehicle type approved under this Regulation an international approval mark consisting of:
- 4.4.1. a circle surrounding the letter "E" followed by the distinguishing number of country which has granted approval; 2/
- 4.4.2. the number of this Regulation followed by the letter "R", a dash, and the approval number to the right of the circle prescribed in paragraph 4.4.1.
- 4.5. If the vehicle conforms to a vehicle type approved, under one or more other Regulations annexed to the Agreement, in the country which has granted approval under this Regulation, the symbol prescribed in paragraph 4.4.1. need not be repeated; in such a case the Regulation and approval numbers and the additional symbols of all the Regulations under which approval has been granted in the country which has granted approval under this Regulation shall be placed in vertical columns to the right of the symbol prescribed in paragraph 4.4.1.
- 4.6. The approval mark shall be clearly legible and be indelible.
- 4.7. The approval mark shall be placed close to or on the vehicle data plate affixed by the manufacturer.
- 4.8. Annex 2 to this Regulation gives examples of the arrangement of the approval marks.

---

2/ 1 for Germany, 2 for France, 3 for Italy, 4 for the Netherlands, 5 for Sweden, 6 for Belgium, 7 for Hungary, 8 for the Czech Republic, 9 for Spain, 10 for Serbia, 11 for the United Kingdom, 12 for Austria, 13 for Luxembourg, 14 for Switzerland, 15 (vacant), 16 for Norway, 17 for Finland, 18 for Denmark, 19 for Romania, 20 for Poland, 21 for Portugal, 22 for the Russian Federation, 23 for Greece, 24 for Ireland, 25 for Croatia, 26 for Slovenia, 27 for Slovakia, 28 for Belarus, 29 for Estonia, 30 (vacant), 31 for Bosnia and Herzegovina, 32 for Latvia, 33 (vacant), 34 for Bulgaria, 35 (vacant), 36 for Lithuania, 37 for Turkey, 38 (vacant), 39 for Azerbaijan, 40 for The former Yugoslav Republic of Macedonia, 41 (vacant), 42 for the European Community (Approvals are granted by its Member States using their respective ECE symbol), 43 for Japan, 44 (vacant), 45 for Australia, 46 for Ukraine, 47 for South Africa, 48 for New Zealand, 49 for Cyprus, 50 for Malta, 51 for the Republic of Korea, 52 for Malaysia, 53 for Thailand, 54 and 55 (vacant), 56 for Montenegro, 57 (vacant) and 58 for Tunisia. Subsequent numbers shall be assigned to other countries in the chronological order in which they ratify or accede to the Agreement Concerning the Adoption of Uniform Technical Prescriptions for Wheeled Vehicles, Equipment and Parts which can be Fitted and/or be Used on Wheeled Vehicles and the Conditions for Reciprocal Recognition of Approvals Granted on the Basis of these Prescriptions, and the numbers thus assigned shall be communicated by the Secretary-General of the United Nations to the Contracting Parties to the Agreement.

5. GENERAL SPECIFICATIONS

- 5.1. The lighting and light-signalling devices shall be so fitted that in normal conditions of use, and notwithstanding the vibrations to which they may be subjected, they retain the characteristics prescribed by this Regulation and enable the vehicle to comply with the requirements of this Regulation. In particular, it shall not be possible for the lamps to be inadvertently maladjusted.
- 5.2. The illuminating lamps shall be so installed that correct adjustment of their orientation can easily be carried out.
- 5.3. For all light-signalling devices, including those mounted on the side, the reference axis of the lamp when fitted to the vehicle shall be parallel to the bearing plane of the vehicle on the road; in addition, it shall be perpendicular to the median longitudinal plane of the vehicle in the case of side retro-reflectors and parallel to that plane in the case of all other devices.  
A tolerance of  $\pm 3^\circ$  shall be allowed in each direction.  
In addition, if specifications for fitting are provided by the manufacturer they shall be complied with.
- 5.4. In the absence of specific instructions, the height and orientation of the lamps shall be verified with the vehicle unladen and placed on a flat horizontal surface, its median longitudinal plane being vertical and the handlebars being in the position corresponding to the straight ahead movement.
- 5.5. In the absence of specific instructions:
- 5.5.1. single lamps or reflectors shall be mounted such that their centre of reference lies in the median longitudinal plane of the vehicle;
- 5.5.2. lamps constituting a pair and having the same function shall:
- 5.5.2.1. be mounted symmetrically in relation to the median longitudinal plane;
- 5.5.2.2. be symmetrical to one another in relation to the median longitudinal plane;
- 5.5.2.3. satisfy the same colorimetric requirements;
- 5.5.2.4. have identical nominal photometric characteristics; and
- 5.5.2.5. come on and go off simultaneously.

5.6. Lamps may be grouped, combined or reciprocally incorporated with one another provided that all the requirements regarding colour, position, orientation, geometric visibility, electrical connections and other requirements, if any, for each lamp are fulfilled.

5.7. The maximum height above ground shall be measured from the highest point and the minimum height from the lowest point of the apparent surface in the direction of the reference axis. For passing beam headlamps, the minimum height from the ground shall be measured from the lowest point of the effective outlet of the optical system (e.g. reflector, lens, projection lens) independent of its utilisation.

Where the (maximum and minimum) height above the ground clearly meets the requirements of the Regulation, the exact edges of any surface need not be determined.

When referring to the distance between lamps, the position, as regards width, shall be determined from the inner edges of the apparent surface in the direction of the reference axis.

Where the position, as regards width, clearly meets the requirements of the Regulation, the exact edges of any surface need not be determined.

5.8. In the absence of specific instructions, no lamps other than direction-indicator lamps and the vehicle-hazard warning signal shall be flashing lamps.

5.9. No red light shall be visible towards the front and no white light shall be visible towards the rear. Compliance with this requirement shall be verified as shown hereunder (see drawing in Annex 4):

5.9.1. visibility of red light towards the front: there must be no direct visibility of a red light if viewed by an observer moving within zone 1 in a transverse plane situated 25 m situated behind the vehicle;

5.9.2. visibility of white light towards the rear: white lamp must be no direct visibility by an observer moving within zone 2 of a transverse plane situated 25 m situated behind the vehicle;

5.9.3. zones 1 and 2, as seen by the observer, are limited in their respective planes as follows:

5.9.3.1. in height, by two horizontal planes 1 m and 2.2 m respectively above the ground;

5.9.3.2. in width, by two vertical planes which, forming to the front and the rear respectively an angle of 15° outwards from the vehicle's median longitudinal plane, pass through the point or points of contact of vertical planes parallel to the vehicle's median

longitudinal plane and delimiting the vehicle's over-all width; if there are several points of contact, the foremost shall correspond to the forward plane and the rearmost to the rearward plane.

5.10. The electrical connections shall be such that the front position lamp, or the passing beam headlamp, if there is no front position lamp, and the rear position lamp and any rear registration plate illuminating device cannot be switched on or off otherwise than simultaneously.

5.11. In the absence of specific instructions, the electrical connection shall be such that the driving beam headlamp and the passing beam headlamp cannot be switched on unless the lamps referred to in paragraph 5.10. above are likewise switched on. This requirement need not, however, be satisfied in the case of the driving beam headlamp and passing beam headlamp where their luminous warnings consist in switching on the passing-beam headlamp intermittently, at short intervals, or in switching on the passing beam headlamp and driving beam headlamp alternately at short intervals.

5.11.1. The headlamp shall automatically be on when the engine is running.

5.12. Tell-tale lamps

5.12.1. Every tell-tale lamp shall be readily visible to a driver in the normal driving position.

5.12.2. Where a "circuit-closed" tell-tale is prescribed by this Regulation, it may be replaced by an "operating" tell-tale.

5.13. Colours of the lights <sup>3/</sup>

The colours of the lights referred to in this Regulation shall be as follows:

driving beam headlamp:	white
passing beam headlamp:	white
front position lamp:	white
front retro-reflector non triangular:	white
side retro-reflector, non-triangular:	amber at the front amber or red at the rear
pedal retro-reflector:	amber
rear retro-reflector, non-triangular:	red
direction-indicator lamp:	amber

---

<sup>3/</sup> Measurement of the chromaticity coordinates of the light emitted by the lamps is not part of this Regulation.

stop lamp: red  
rear position lamp: red  
rear-registration plate lamp: white

- 5.14. Every vehicle submitted for approval pursuant to this Regulation shall be equipped with the following lighting and light-signalling devices:
- 5.14.1. passing beam headlamp (paragraph 6.2.);
  - 5.14.2. rear position lamp (paragraph 6.10.);
  - 5.14.3. side retro-reflector, non-triangular (paragraph 6.5.);
  - 5.14.4. rear retro-reflector, non-triangular (paragraph 6.7.);
  - 5.14.5. pedal retro-reflectors (paragraph 6.6.), only for mopeds with pedals;
  - 5.14.6. stop lamp (paragraph 6.9.);
  - 5.14.7. Rear registration plate illuminating device, where such a plate is required (paragraph 6.11.).
- 5.15. It may, in addition, be equipped with the following lighting and light-signalling devices:
- 5.15.1. driving beam headlamp (paragraph 6.1.);
  - 5.15.2. front position lamp (paragraph 6.3.);
  - 5.15.3. front retro-reflector, non triangular (paragraph 6.4.).
  - 5.15.4. direction-indicator lamps (paragraph 6.8.)
- 5.16. The fitting of each of the lighting and light-signalling devices mentioned in paragraphs 5.14. and 5.15. above shall be effected in conformity with the relevant requirements in paragraph 6 of this Regulation.
- 5.17. The fitting of any lighting and light-signalling devices other than those mentioned in paragraphs 5.14. and 5.15. is prohibited with the exception of an appropriate illuminating device for the rear-registration plate if it exists and its lighting is required.
- 5.18. Lighting and light-signalling devices type-approved for motorcycles and referred to in sections 5.16. and 5.17. may also be fitted to mopeds.

6. INDIVIDUAL SPECIFICATIONS

6.1. DRIVING BEAM HEADLAMP

6.1.1. Number

One or two of approved type according to:

- (a) Regulation No. 113;
- (b) Class A of Regulation No. 112;
- (c) Regulation No. 1;
- (d) Regulation No. 57;
- (e) Regulation No. 72;
- (f) Regulation No. 76.

6.1.2. Arrangement

No special requirement.

6.1.3. Position

6.1.3.1. Width

6.1.3.1.1. an independent driving lamp may be fitted above or below or to one side of another front lamp: if these lamps are on top of the other the reference centre of the driving lamp must be located within the median longitudinal plane of the vehicle; if these lamps are side by side their reference centre must be symmetrical in relation to the median longitudinal plane of the vehicle.

6.1.3.1.2. a driving beam headlamp that is reciprocally incorporated with another front lamp must be fitted in such a way that its reference centre lies within the median longitudinal plane of the vehicle. However, when the vehicle is also fitted with an independent passing beam headlamp or a passing beam headlamp that is reciprocally incorporated with a front position lamp alongside the driving beam headlamp their reference centres must be symmetrical in relation to the median longitudinal plane of the vehicle.

6.1.3.1.3. two driving lamps of which either one or both are reciprocally incorporated with another front lamp must be fitted in such a way that their reference centres are symmetrical in relation to the median longitudinal plane of the vehicle.

6.1.3.2. Length: at the front of the vehicle. This requirement is regarded as satisfied if the light emitted does not cause discomfort to the driver either directly or indirectly by means of the rear-view mirrors and/or reflective surfaces on the vehicle.



- 6.1.3.3. In any case, the distance between the edge of the illumination surface of any independent driving lamp and the edge of that of the passing lamp must not exceed 200 mm.
- 6.1.3.4. The distance separating the illuminating surfaces of two driving lamps must not exceed 200 mm.
- 6.1.4. Geometric visibility  
The visibility of the illuminating surface, including its visibility in areas which do not appear to be illuminated in the direction of observation considered, shall be ensured within a divergent space defined by generating lines based on the perimeter of the illuminating surface and forming an angle of not less than 5° with the axis of reference of the headlamp.
- 6.1.5. Orientation  
Forwards. The lamp(s) may move in line with the steering angle.
- 6.1.6. May not be "combined" with any other lamp.
- 6.1.7. Electrical connections  
The passing beam(s) may remain illuminated with the driving beam(s).
- 6.1.8. "Circuit-closed" tell-tale  
Mandatory, non-flashing blue signal lamp.
- 6.2. PASSING BEAM HEADLAMP
- 6.2.1. Number  
  
One or two of approved type according to:  
(a) Regulation No. 113;  
(b) Class A of Regulation No. 112;  
(c) Regulation No. 1;  
(d) Regulation No. 56;  
(e) Regulation No. 57;  
(f) Regulation No. 72;  
(g) Regulation No. 76  
(h) Regulation No. 82.
- 6.2.2. Arrangement  
  
No special requirement.

6.2.3. Position

6.2.3.1. Width

6.2.3.1.1. an independent passing lamp may be installed above, below or to one side of another front lamp: if these lamps are one above the other the reference centre of the passing lamp must be located within the median longitudinal plane of the vehicle; if these lamps are side by side their reference centre must be symmetrical in relation to the median longitudinal plane of the vehicle.

6.2.3.1.2. a passing beam headlamp, that is reciprocally incorporated with another front lamp, must be fitted in such a way that its reference centre lies within the median longitudinal plane of the vehicle. However, when the vehicle is also fitted with an independent driving beam headlamp, or a driving beam headlamp that is reciprocally incorporated with a front position lamp alongside the passing beam headlamp, their reference centres must be symmetrical in relation to the median longitudinal plane of the vehicle.

6.2.3.1.3. two passing lamps, of which either one or both are reciprocally incorporated with another front lamp must be installed in such a way that their reference centres are symmetrical in relation to the median longitudinal plane of the vehicle.

6.2.3.2. Height: a minimum of 500 mm and a maximum of 1,200 mm above the ground.

6.2.3.3. Length: at the front of the vehicle. This requirement is regarded as satisfied if the light emitted does not cause discomfort to the driver either directly or indirectly by means of the rear-view mirrors and/or reflective surfaces of the vehicle.

6.2.3.4. In the case of two passing lamps the distance separating the illuminating surfaces must not exceed 200 mm.

6.2.4. Geometric visibility

Defined by angles  $\alpha$  and  $\beta$  as specified in paragraph 2.11.:

$\alpha = 15^\circ$  and  $10^\circ$  downwards;

$\beta = 45^\circ$  to the left and to the right for a single lamp;

$\beta = 45^\circ$  outwards and  $10^\circ$  inwards for each pair of lamps.

The presence of partitions or other items of equipment near the head-lamp shall not give rise to secondary effects causing discomfort to other road users.

6.2.5. Orientation

Forwards. The lamp(s) may move in line with the steering angle.

6.2.6. May not be "combined" with any other lamp.

- 6.2.7. Electrical connections  
The control for changing over to the passing beam(s) shall switch off the driving beam(s) simultaneously.
- 6.2.8. Tell tale  
Optional, circuit-closed, green, non flashing.
- 6.3. FRONT POSITION LAMP
- 6.3.1. Number  
One or two.
- 6.3.2. Arrangement  
No special requirement.
- 6.3.3. Position
- 6.3.3.1. Width:  
an independent front position lamp may be fitted above or below, or to one side of another front lamp: if these lamps are one above the other the reference centre of the front position lamp must be located within the median longitudinal plane of the vehicle; if these lamps are side by side their reference centres must be symmetrical in relation to the median longitudinal plane of the vehicle;
- a front position lamp that is reciprocally incorporated with another front lamp must be installed in such a way that its reference centre is situated in the median longitudinal plane of the vehicle. However, when the vehicle is also fitted with another front lamp alongside the front position lamp, their reference centres must be symmetrical in relation to the median longitudinal plane of the vehicle.
- Two front position lamps, one or both of them reciprocally incorporated with another front lamp must be installed in such a way that their reference centres are symmetrical in relation to the median longitudinal plane of the vehicle.
- 6.3.3.2. in height: not less than 350 mm nor more than 1200 mm above the ground;
- 6.3.3.3. in length: at the front of the vehicle.

- 6.3.4. Geometric visibility  
the vertical angle: 15° and downwards;  
however, the vertical angle below the horizontal may be reduced to 5° if the height of the lamps is less than 750 mm  
the horizontal angle: 80° to the left and to the right for a single lamp;  
  
the horizontal angle may be 80° outwards and 45° inwards for each pair of lamps.
- 6.3.5. Orientation  
Forwards. The lamp(s) may move in line with the steering angle.
- 6.3.6. Tell tale  
Either an optional, circuit-closed, green, non-flashing tell tale or instrument illumination.
- 6.3.7. Other requirements  
None.
- 6.4. FRONT RETRO-REFLECTOR, NON-TRIANGULAR
- 6.4.1. Number  
One.
- 6.4.2. Arrangement  
No special requirement.
- 6.4.3. Position  
in height: not less than 400 mm nor more than 1,200 mm above the ground;
- 6.4.4. Geometric visibility  
Horizontal angle : 30° to the left and to the right.  
Vertical angle: 15° above and below the horizontal.  
  
The vertical angle below the horizontal may be reduced to 5°, however, if the height of the reflector is less than 750 mm.
- 6.4.5. Orientation  
Forwards. The reflector may move in line with the steering angle.
- 6.4.6. Other requirements  
None.

6.5. SIDE RETRO-REFLECTOR, NON-TRIANGULAR

6.5.1. Number per side

One or two.

6.5.2. Arrangement

No special requirement.

6.5.3. Position

6.5.3.1. on the side of the vehicle.

6.5.3.2. in height: not less than 300 mm or more than 1,000 mm above the ground;

6.5.3.3. in length: should be placed in such a position that under normal conditions it may not be masked by the driver's or passenger's clothes.

6.5.4. Geometric visibility

Horizontal angle: 30° to the front and to the rear.

Vertical angle: 15° above and below the horizontal.

The vertical angle below the horizontal may be reduced to 5°, however, if the height of the lamp is less than 750 mm.

6.5.5. Orientation

The reference axis of the retro-reflectors must be perpendicular to the vehicle's median longitudinal plane and directed outwards. The front side retro-reflectors may move with the steering angle.

6.6. PEDAL RETRO-REFLECTORS

6.6.1. Number

Four retro-reflectors or retro-reflector groups.

6.6.2. Arrangement

No special requirement.

6.6.3. Other requirements

The outer faces of the illuminating surface of the retro-reflectors shall be recessed into the body of the pedal.

The retro-reflectors shall be mounted in the pedal body in such a way as to be clearly visible both to the front and to the rear of the vehicle. The reference axis of such retro-reflectors, the shape of which shall be adapted to that of the pedal body, shall be perpendicular to the pedal axis.

Pedal retro-reflectors shall be fitted only to those pedals of the vehicle which, by means of cranks or similar devices, can be used to provide a means of propulsion alternative to the engine.

They shall not be fitted to pedals which serve as controls for the vehicle or which serve only as footrests for the rider or passenger.

They shall be visible to the front and the rear.

6.7. REAR RETRO-REFLECTOR, NON-TRIANGULAR

6.7.1. Number

One or two.

6.7.2. Arrangement

No special requirement.

6.7.3. Position

6.7.3.1. in height: not less than 250 mm nor more than 900 mm above the ground.

6.7.3.2. in length: at the rear of the vehicle.

6.7.4. Geometric visibility

Horizontal angle: 30° to left and to right for a single reflector;  
30° outwards and 10° inwards for each pair of reflectors;

Vertical angle: 15° above and below the horizontal.

The vertical angle below the horizontal may be reduced to 5°, however, if the height of the lamp is less than 750 mm.

6.7.5. Orientation

Rearwards.

6.8. DIRECTION-INDICATOR LAMP

6.8.1. Number

Two per side.

6.8.2. Arrangement

Two front indicators (category 11 1/);

Two rear indicators (category 12 4/).

---

4/ May be replaced by indicators of categories 1 and 2 respectively of Regulation No. 6.

6.8.3. Position

6.8.3.1. in width:

6.8.3.1.1. For front indicators, the following requirements shall all be met:

- (1) there shall be a minimum distance of 240 mm between illuminating surfaces;
- (2) the indicators shall be situated outside the longitudinal vertical plane tangential to the outer edges of the illuminating surface of the headlamp(s);
- (3) there shall be a minimum distance between the illuminating surface of the indicators and passing beam headlamp closest to one another as follows:

Minimum indicator intensity (cd)	Minimum separation (mm)
90	75
175	40
250	20
400	≤ 20

6.8.3.1.2. For rear indicators, the clearance between the inner edges of the two apparent surfaces shall be at least 160 mm.

6.8.3.2. In height: not less than 350 mm or more than 1,200 mm above the ground.

6.8.3.3. in length: the forward distance between the centre of reference of the rear indicators and the transverse plane which constitutes the rearmost limit of the vehicle's over-all length shall not exceed 300 mm.

6.8.4. Geometric visibility

Horizontal angle: 20° inwards and 80° outwards.

Vertical angle: 15° above and below the horizontal.

The vertical angle below the horizontal may be reduced to 5°, however, if the height of the lamp is less than 750 mm.

6.8.5. Orientation

The front indicators may move in line with the steering angle.

6.8.6. May not be "combined" with any other lamp.

6.8.7. May not be "reciprocally incorporated" with any other lamp.

6.8.8. Electrical connections

Direction-indicator lamps shall light up independently of the other lamps. All the direction-indicator lamps on one side of a vehicle shall be switched on and off by means of one control.

6.8.9. Other requirements

The characteristics indicated below shall be measured with no other load on the electrical system except that which is required for the operation of the engine and lighting devices.

6.8.9.1. In the case of all vehicles which supply direct current to the direction indicators, the light flashing frequency shall be  $90 \pm 30$  times per minute.

6.8.9.1.1. The flashing of the direction indicators on the same side of the vehicle may occur synchronously or alternately.

6.8.9.1.2. Operation of the light-signal control shall be followed within not more than one second by the appearance of the light from any of the indicators and within not more than one-and-a-half seconds by the first extinction of the light.

6.8.9.2. In the case of a vehicle which supplied alternating current to the direction indicators, where the speed of the engine is between 50 per cent and 100 per cent of the engine speed corresponding to the maximum design speed of the vehicle; the light flashing frequency shall be  $90 \pm 30$  times per minute.

6.8.9.2.1. The flashing of the direction indicators on the same side of the vehicle may occur synchronously or alternately.

6.8.9.2.2. Operation of the lamp-signal control shall be followed within not more than one second by the appearance of the light from any of the indicators and within not more than one-and-one-half seconds by the first extinction of the light.

6.8.9.3. In the case of a vehicle which supplies alternating current to the direction indicators, where the speed of the engine is between the idling speed indicated by the manufacturer and 50 per cent of the engine speed corresponding to the maximum speed of the vehicle, the lamp flashing frequency shall be between  $90 + 30$  and  $90 - 45$  times per minute;

6.8.9.3.1. The flashing of the direction indicators on the same side of the vehicle may occur synchronously or alternately.



- 6.8.9.3.2. Operation of the lamp-signal control shall be followed within not more than one second by the appearance of the light from any of the indicators and within not more than one-and-one-half seconds by the first extinction of the light.
- 6.8.10. In the event of failure, other than a short circuit, of one direction indicator lamp, the other must continue to flash or remain alight but the frequency in this condition shall be different from that prescribed, unless the vehicle is equipped with a tell-tale.
- 6.8.11. Tell tale  
Mandatory if the direction indicators are not visible to the rider: operational, green, flashing and/or audible. In the event of an indicator malfunction the tell tale shall; go off, stay on or change frequency.
- 6.9. STOP LAMP
- 6.9.1. Number  
One or two.
- 6.9.2. Arrangement  
No special requirement.
- 6.9.3. Position
- 6.9.3.1. in height: not less than 250 mm or more than 1,500 mm above the ground;
- 6.9.3.2. in length: at the rear of the vehicle.
- 6.9.4. Geometric visibility  
Horizontal angle : 45° to left and to right for a single lamp:  
45° outwards and 10° inwards for each pair of lamps:  
Vertical angle: 15° above and below the horizontal.
- The vertical angle below the horizontal may be reduced to 5°, however, if the height of the lamp is less than 750 mm.
- 6.9.5. Orientation  
Rearwards.
- 6.9.6. Electrical connections  
Shall light up at any service brake application.
- 6.9.7. Other requirements  
The luminous intensity of the stop lamp shall be markedly greater than that of the rear position lamp.

- 6.9.8. Tell tale  
Prohibited.
- 6.10. REAR POSITION LAMP
- 6.10.1. Number  
One or two.
- 6.10.2. Arrangement  
No special requirement.
- 6.10.3. Position
- 6.10.3.1. in height: not less than 250 mm nor more than 1,500 mm above the ground;
- 6.10.3.2. in length at the rear of the vehicle.
- 6.10.4. Geometric visibility  
Horizontal angle: 80° to left and to right for a single lamp:  
the horizontal angle may be 80° outwards and 45° inwards for each pair of lamps:  
  
Vertical angle: 15° above and below the horizontal.  
The vertical angle below the horizontal may be reduced to 5°, however, if the height of the lamp is less than 750 mm.
- 6.10.5. Orientation  
Rearwards.
- 6.10.6. Tell tale  
Optional, shall be combined with that for the front position lamp.
- 6.10.7. Other requirements  
None.
- 6.11. REAR-REGISTRATION-PLATE ILLUMINATING DEVICE
- 6.11.1. Number  
One. The device may consist of several optical components designed to illuminate the space reserved for the registration plate.

- 6.11.2. Arrangement )  
)  
6.11.3. Position )  
)  
6.11.3.1. in width: ) Such that the device illuminates  
) the space reserved for the  
6.11.3.2. in height: ) registration plate.  
)  
6.11.3.3. in length: )  
)  
6.11.4. Geometric visibility )  
)  
6.11.5. Orientation )  
)  
6.11.6. Tell-tale  
Optional: Its function shall be performed by the tell-tale prescribed for the position  
lamp.  
6.11.7. Other requirements

When the rear registration plate lamp is combined with the rear position lamp, reciprocally incorporated in the stop lamp, the photometric characteristics of the rear registration plate lamp may be modified during the illumination of the stop lamp.

## 7. REGISTRATION OF VEHICLES

Nothing shall prevent a Government from requiring or prohibiting the presence of a driving lamp as mentioned in paragraph 5.15.1. on vehicles registered in its territory, provided that it so notifies the Secretary General of the United Nations at the time of its communication the application of this Regulation.

## 8. CONFORMITY OF PRODUCTION

The conformity of production procedures shall comply with those set out in the Agreement, Appendix 2 (E/ECE/324 - E/ECE/TRANS/505/Rev.2), with the following requirements:

- 8.1. Mopeds approved under this Regulation shall be so manufactured as to conform to the type approved by meeting the requirements set out in paragraphs 5. and 6. above.
- 8.2. The minimum requirements for conformity of production control procedures set forth in Annex 5 to this Regulation shall be complied with.

8.3. The authority which has granted type approval may at any time verify the conformity control methods applied in each production facility. The normal frequency of these verifications shall be once a year.

## 9. PENALTIES FOR NON-CONFORMITY OF PRODUCTION

9.1. The approval granted in respect of a vehicle type pursuant to this Regulation may be withdrawn if the requirements set forth above are not met.

9.2. If a Contracting Party to the Agreement applying this Regulation withdraws an approval it has previously granted, it shall forthwith so notify the other Contracting Parties applying this Regulation, by means of a communication form conforming to the model in Annex 1 to this Regulation.

## 10. MODIFICATION AND EXTENSION OF APPROVAL OF A VEHICLE TYPE WITH REGARD TO THE INSTALLATION OF LIGHTING AND LIGHT-SIGNALLING DEVICES

10.1. Every modification of the vehicle type shall be notified to the Administrative Department which approved that vehicle type. The department may then either:

10.1.1. Consider that the modifications made are unlikely to have an appreciable adverse effect and that in any case the vehicle still complies with the requirements; or

10.1.2. Require a further test report from the Technical Service responsible for conducting the tests.

10.2. Confirmation or refusal of approval, specifying the alterations shall be communicated by the procedure specified in paragraph 4.3. above to the Parties to the Agreement which apply this Regulation.

10.3. The Competent Authority issuing the extension of approval shall assign a series number for such an extension and inform thereof the other Parties to the 1958 Agreement applying this Regulation by means of a communication form conforming to the model in Annex 1 to this Regulation.

## 11. PRODUCTION DEFINITELY DISCONTINUED

If the holder of the approval completely ceases to manufacture a vehicle type approved in accordance with this Regulation, he shall so inform the authority which granted the approval. Upon receiving the relevant communication that authority shall inform thereof the other Parties to the 1958 Agreement applying this Regulation by means of a communication form conforming to the model in Annex 1 to this Regulation.

12. TRANSITIONAL PROVISIONS

12.1. As from the official date of entry into force of the 01 series of amendments, no Contracting Party applying this Regulation shall refuse to grant approvals under this Regulation as amended by the 01 series of amendments.

12.2. As from 24 months after the date of entry into force mentioned in paragraph 12.1. above, Contracting Parties applying this Regulation shall grant approvals only if the vehicle type with regard to the number and mode of installation of the lighting and light-signalling devices corresponds to the requirements of the 01 series of amendments to this Regulation.

12.3. Existing approvals granted under this Regulation before the date mentioned in paragraph 12.2. above shall remain valid. In the case of vehicles first registered more than four years after the date of entry into force mentioned in paragraph 12.1. above Contracting Parties applying this Regulation may refuse the vehicle type with regard to the number and mode of installation of the lighting and light-signalling devices which do not meet the requirements of the 01 series of amendments to this Regulation.

13. NAMES AND ADDRESSES OF TECHNICAL SERVICES RESPONSIBLE FOR CONDUCTING APPROVAL TESTS AND OF ADMINISTRATIVE DEPARTMENTS

The Parties to the Agreement which apply this Regulation shall communicate to the United Nations Secretariat the names and addresses of the Technical Services responsible for conducting approval tests and of the Administrative Departments which grant approval and to which forms certifying approval or refusal or withdrawal of approval, issued, in other countries, are to be sent.

Annex 1

COMMUNICATION

(maximum format: A4 (210 x 297 mm))



issued by:      Name of administration:

.....  
.....  
.....

concerning: 2/      APPROVAL GRANTED  
                                 APPROVAL EXTENDED  
                                 APPROVAL REFUSED  
                                 APPROVAL WITHDRAWN  
                                 PRODUCTION DEFINITELY DISCONTINUED

of a vehicle type (moped) with regard to the installation of lighting and light-signalling devices pursuant to Regulation No. 74

Approval No.: .....

Extension No.: .....

1. Trade name or mark of the vehicle:.....
2. Vehicle type:.....
3. Manufacturer's name and address: .....
4. If applicable, name and address of manufacturer's representative.....  
.....
5. Lighting devices on the vehicles submitted for approval 3/ 4/
  - 5.1. Driving lamp: yes/no 2/
  - 5.2. Passing lamp: yes/no 2/
  - 5.3. Front position lamp: yes/no 2/
  - 5.4. White front retro-reflector, non-triangular: yes/no 2/
  - 5.5. Amber side retro-reflectors, non-triangular: yes/no 2/

- 5.6. Amber pedal retro-reflectors: yes/no 2/
- 5.7. Rear red retro-reflector, non-triangular: yes/no 2/
- 5.8. Direction-indicator lamp: yes/no 2/
- 5.9. Stop lamp: yes/no 2/
- 5.10. Rear position lamp: yes/no 2/
- 5.11. Rear-registration-plate illuminating device: yes/no 2/
- 6. Maximum design speed: ..... km/h
- 7. Variants: .....
- 8. Vehicle submitted for approval on: .....
- 9. Technical Service responsible for conducting approval tests: .....
- 10. Date of report issued by that service: .....
- 11. Number of report issued by that service: .....
- 12. Approval granted/refused/extended/withdrawn 2/
- 13. Reason(s) of extension (if applicable): .....
- 14. Position of approval mark on the vehicle: .....
- 15. Place: .....
- 16. Date: .....
- 17. Signature: .....

---

1/ Distinguishing number of the country which has granted/extended/refused/withdrawn approval see approval provisions in the Regulation).

2/ Strike out what does not apply.

3/ Show for each device, on a separate form (list prescribed in paragraph 3.2.2. of this Regulation), the types of devices, duly identified, meeting the installation requirements of this Regulation.

4/ Attach diagrams of the vehicles, as indicated in paragraph 3.2.3. of this Regulation.

Annex 2

ARRANGEMENTS OF APPROVAL MARKS

Model A

(See paragraph 4.4. of this Regulation)



a = 8 mm min.

The above approval mark affixed to a moped shows that the vehicle type concerned has, with regard to the installation of lighting and light-signalling devices, been approved in the Netherlands (E4), pursuant to Regulation No. 74 under approval number 012439. The first two digits of the approval number indicate that the approval was granted in accordance with the requirements of Regulation No. 74, as amended by the 01 series of amendments.

Model B

(See paragraph 4.5. of this Regulation)

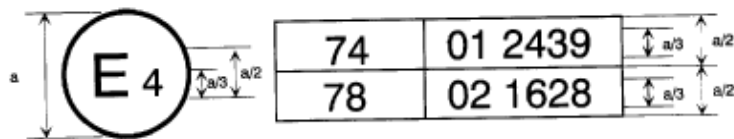

a = 8 mm min.

The above approval mark affixed to a moped shows that the vehicle type concerned has been approved in the Netherlands (E4) pursuant to Regulations Nos. 74 and 78. 1/ The approval numbers indicate that, at the dates when the respective approvals were given, Regulation No. 74 included the 01 series of amendments and Regulation No. 78 already included the 02 series of amendments.

---

1/ The latter is given merely as an example



Annex 3

LAMP SURFACES, AXIS AND CENTRE OF REFERENCE,  
 AND ANGLES OF GEOMETRIC VISIBILITY

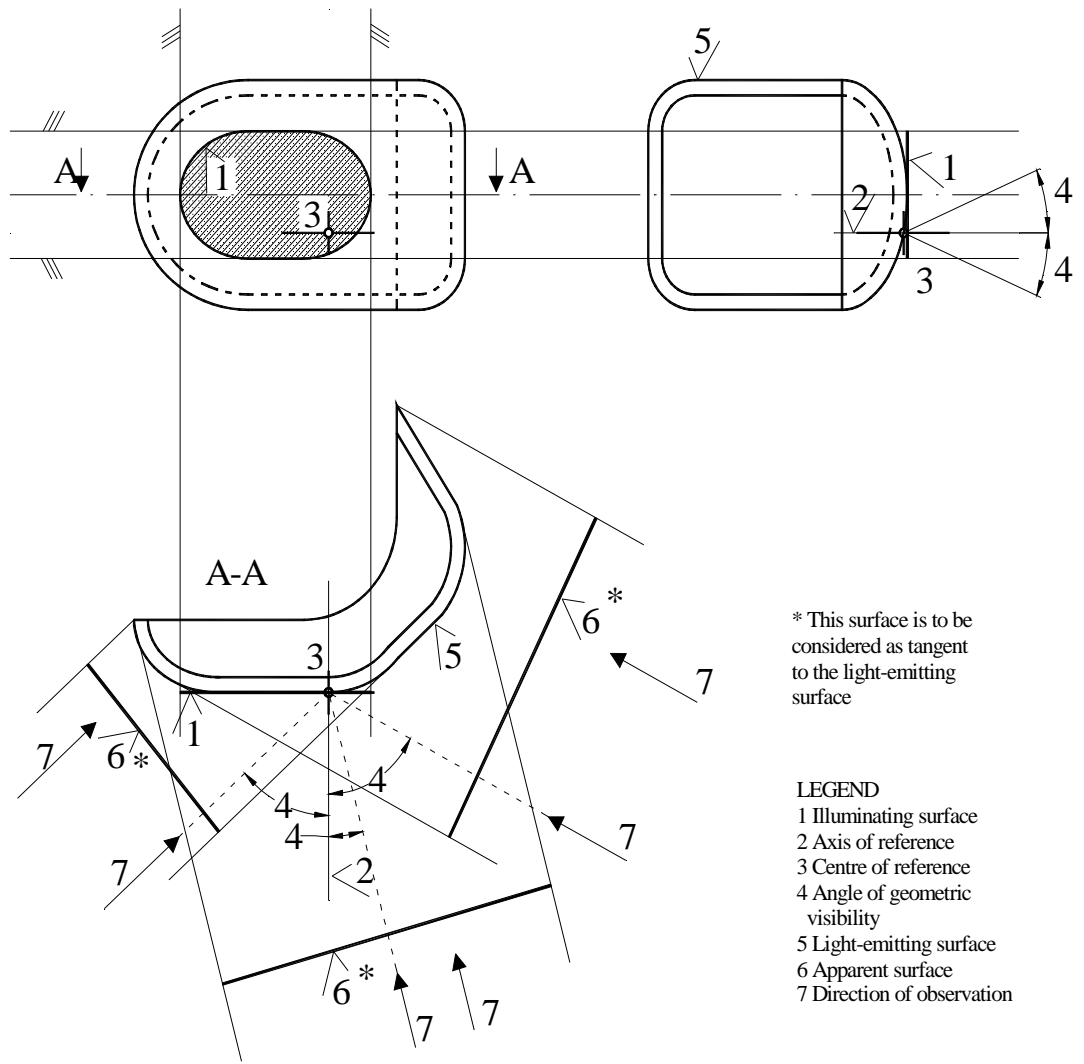

ILLUMINATING SURFACE IN COMPARISON WITH LIGHT-EMITTING SURFACE

(See paragraphs 2.9. and 2.8 of this Regulation)

SKETCH A

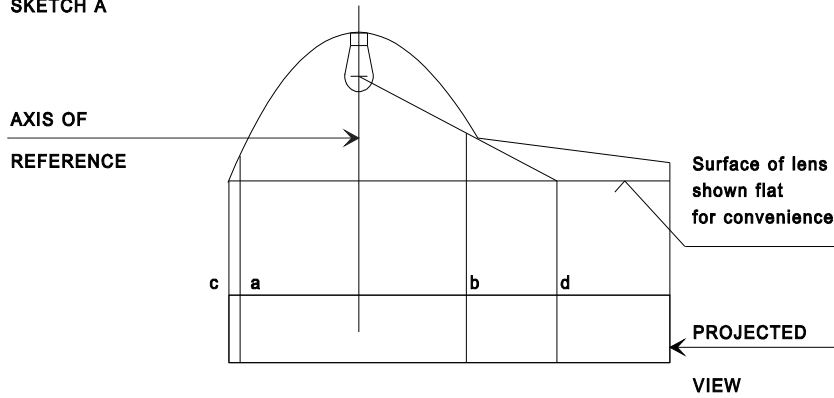

	illuminating surface	Light-emitting surface
Edges are	a and b	c and d

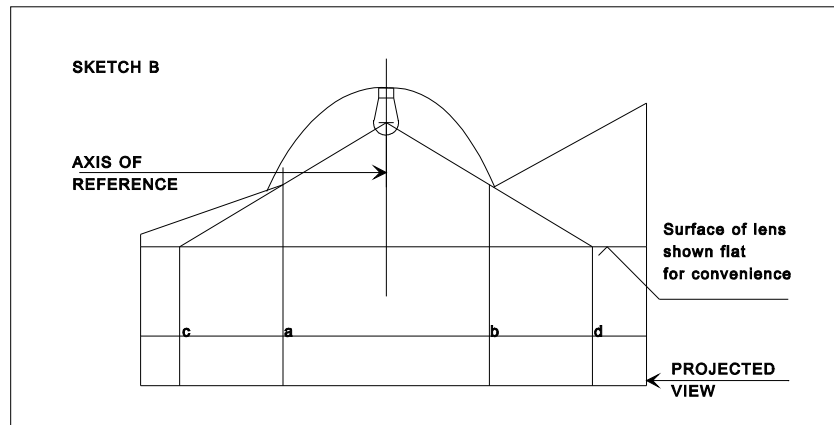

	illuminating surface	Light-emitting surface
Edges are	a and b	c and d

Annex 4

FORWARD VISIBILITY OF RED LIGHTS AND REARWARD VISIBILITY OF WHITE LIGHTS

(See paragraph 5.9. of this Regulation)

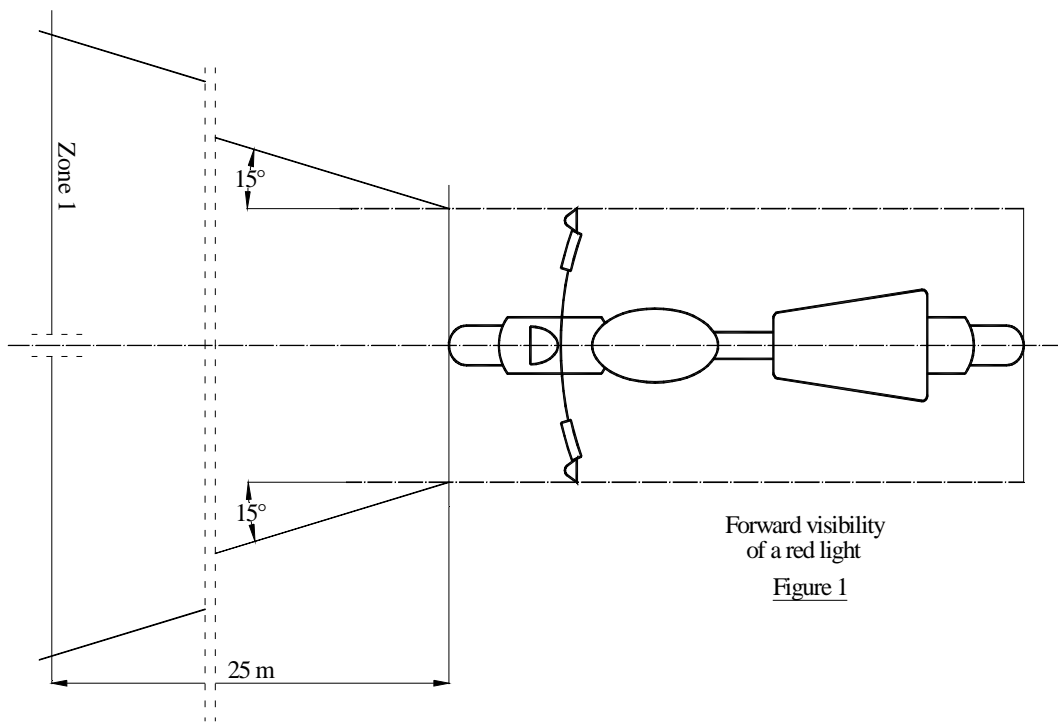

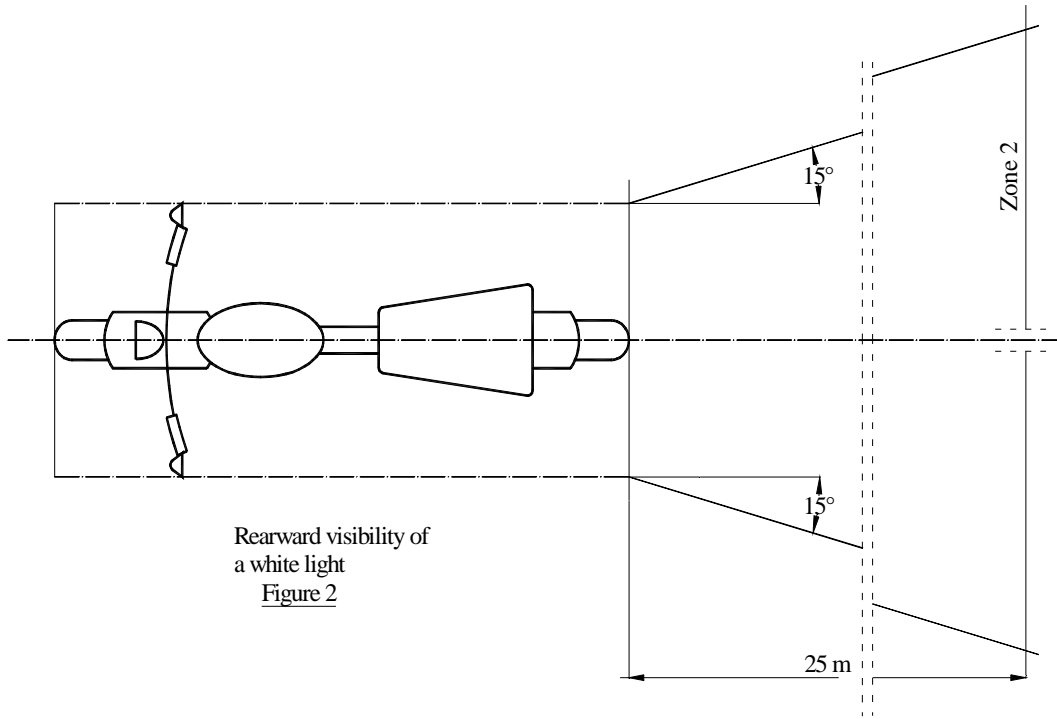

Rearward visibility of  
a white light  
Figure 2

Annex 5

CONTROL OF CONFORMITY OF PRODUCTION

1. TESTS

1.1. Position of lamps

The position of the lamps as specified in paragraph 6 shall be checked in accordance with the general requirements set out in paragraph 5 of this Regulation.

The values measured for the distances shall be such that the individual specifications applicable to each lamp are fulfilled.

1.2. Visibility of lamps

1.2.1. The angles of geometric visibility shall be checked in accordance with paragraph .11. of this Regulation.

The values measured for the angles shall be such that the individual specifications applicable to each lamp are fulfilled except that the limits of the angles may have an allowance corresponding to the  $\pm 3^\circ$  variation permitted in paragraph 5.3. for the mounting of the light-signalling devices.

1.2.2. The visibility of red light towards the front and of white light towards the rear shall be checked in accordance with paragraph 5.9. of this Regulation.

1.3. Electrical connections and tell-tales

The electrical connections shall be checked by switching on every lamp supplied by the electrical system of the moped. The lamps and tell-tales shall function in accordance with the provisions set out in paragraph 5.10. of this Regulation and with the individual specifications applicable to each lamp.

1.4. The presence number, colour, arrangement and, where applicable, the category of lamps shall be checked by visual inspection of the lamps and their markings.

These shall be such that the requirements set out in paragraph 5.13. and the individual specifications applicable to each lamp are fulfilled.

- - - - -