

18 February 2009

AGREEMENT

CONCERNING THE ADOPTION OF UNIFORM TECHNICAL PRESCRIPTIONS FOR WHEELED VEHICLES, EQUIPMENT AND PARTS WHICH CAN BE FITTED AND/OR BE USED ON WHEELED VEHICLES AND THE CONDITIONS FOR RECIPROCAL RECOGNITION OF APPROVALS GRANTED ON THE BASIS OF THESE PRESCRIPTIONS */

(Revision 2, including the amendments which entered into force on 16 October 1995)

Addendum 68: Regulation No. 69

Revision 1

Incorporating all valid text up to:

The 01 series of amendments – Date of entry into force: 27 September 1997

Corrigendum 1 to the 01 series of amendments, subject of Depositary Notification

C.N.226.1997.TREATIES-43 dated 20 June 1997

Supplement 1 to the 01 series of amendments - Date of entry into force: 7 February 1999

Supplement 2 to the 01 series of amendments - Date of entry into force: 5 December 2001

Supplement 3 to the 01 series of amendments - Date of entry into force: 18 June 2007

Supplement 4 to the 01 series of amendments - Date of entry into force: 15 October 2008

UNIFORM PROVISIONS CONCERNING THE APPROVAL OF REAR MARKING PLATES FOR SLOW-MOVING VEHICLES (BY CONSTRUCTION) AND THEIR TRAILERS



UNITED NATIONS

*/ Former title of the Agreement:

Agreement Concerning the Adoption of Uniform Conditions of Approval and Reciprocal Recognition of Approval for Motor Vehicle Equipment and Parts, done at Geneva on 20 March 1958.

GE.09-

Regulation No. 69

UNIFORM PROVISIONS CONCERNING THE APPROVAL OF REAR MARKING PLATES
FOR SLOW-MOVING VEHICLES (BY CONSTRUCTION) AND THEIR TRAILERS

CONTENTS

REGULATION	<u>Page</u>
1. Scope	5
2. Definitions	5
3. Applications for approval	8
4. Markings	8
5. Approval	9
6. General specifications	10
7. Special specification (tests)	11
8. Modifications and extension of approval of rear marking plates for slow-moving vehicles (by construction) and their trailers	11
9. Conformity of production	11
10. Penalties for non-conformity of production	12
11. Production definitely discontinued	12
12. Transitional provisions	12
13. Names and addresses of Technical Services responsible for conducting approval tests, and of Administrative Departments	13

CONTENTS (continued)

ANNEXES

- Annex 1 - The CIE co-ordinate system
- Annex 2 - Communication concerning the approval or refusal or extension or withdrawal of approval or production definitely discontinued of a type of SMV rear marking plate, pursuant to Regulation No. 69
- Annex 3 - Arrangement of the approval mark
- Annex 4 - Test procedure
- Annex 5 - Specifications of shape and dimensions - shape and dimensions of retro-reflective/fluorescent (class 1) or retro-reflective only (class 2) SMV rear marking plates
- Annex 6 - Colorimetric specifications
- Annex 7 - Photometric specifications
- Annex 8 - Resistance to external agents
- Annex 9 - Resistance to heat
- Annex 10 - Rigidity of the plates
- Annex 11 - Stability in time of the optical properties of rear marking plates
- Annex 12 - Rear marking plates for slow-moving vehicles and their trailers
- Annex 13 - Minimum requirements for conformity of production control procedures
- Annex 14 - Minimum requirements for sampling by an inspector
- Annex 15 - Guidelines for installation of rear marking plates on slow-moving vehicles (by construction) and their trailers

1. SCOPE

This Regulation applies to rear marking plates for vehicles of category M, N, O and T and for mobile machinery, which, by construction, cannot move faster than 40 km/h. 1/

2. DEFINITIONS 2/

2.1 For the purpose of these provisions, the following definitions shall apply:

2.1.1 "SMV rear marking plate", a triangular plate with truncated corners with a characteristic pattern faced with retro-reflective and fluorescent material or devices (class 1); or with retro-reflective materials or devices only (class 2).

2.1.2 "Sample unit", a complete, finished SMV plate ready to be mounted on a vehicle and representative of current production.

2.2 Retro-reflection

Reflection in which radiation is returned in directions close to the direction from which it came, this property being maintained even over wide variations of the direction of the incident radiation:

2.2.1 "Retro-reflective material", a surface or device from which, when directionally irradiated, a relatively large portion of the incident radiation is retroreflected.

2.2.2 "Retro-reflective device", an assembly ready for use and comprising one or more retro-reflective optical units.

2.3 Geometric definitions (see Annex 1, figure 1).

2.3.1 "Reference centre", a point on or near a retro-reflective area which is designated to be the centre of the device for the purpose of specifying its performance.

2.3.2 "Illumination axis", a line segment from the reference centre to the light source.

2.3.3 "Observation axis", a line segment from the reference centre to the photometer head.

1/ As defined in Annex 7 to the Consolidated Resolution on the Construction of Vehicles (R.E.3) (document TRANS/WP.29/78/Rev.1/Amend.2 as last amended by Amend.4).

2/ The definitions of technical terms are those adopted by the International Commission on Illumination (CIE) - see Technical Report on Retro-reflection, CIE Publication No. 54.

- 2.3.4 "Observation angle (symbol α)", the angle between the illumination axis and the observation axis. The observation angle is always positive and, in the case of retro-reflection, is restricted to small angles. Maximum range: $0 \leq \alpha \leq 180^\circ$.
- 2.3.5 "Observation half-plane", the half-plane which originates on the illumination axis and which contains the observation axis.
- 2.3.6 "Reference axis", a designated line segment originating on the reference centre which is used to describe the angular position of the retro-reflective device.
- 2.3.7 "Entrance angle (symbol β)", the angle from the illumination axis to the reference axis. The entrance angle is usually not larger than 90° but, for completeness, its full range is defined as $0 \leq \beta \leq 180^\circ$. In order to specify the orientation in full, this angle is characterized by two components, β_1 and β_2 .
- 2.3.8 "First axis", an axis through the reference centre and perpendicular to the observation half-plane.
- 2.3.9 "First component of the entrance angle (symbol β_1)", the angle from the illumination axis to the plane containing the reference axis and the first axis. Range: $-180^\circ < \beta_1 \leq 180^\circ$.
- 2.3.10 "Second component of the entrance angle (symbol β_2)", the angle from the plane containing the observation half-plane to the reference axis. Range: $-90 \leq \beta_2 \leq 90^\circ$.
- 2.3.11 "Second axis", an axis through the reference centre and perpendicular to both the first axis and the reference axis. The positive direction of the second axis lies in the observation half-plane when $-90^\circ < \beta_1 < 90^\circ$ as shown in Annex 1, figure 1.
- 2.3.12 Angle of rotation ε
- Angle through which the sample is turned about its vertical axis from any arbitrarily established position counterclockwise ($+\varepsilon$) or clockwise ($-\varepsilon$) viewed in the direction of illumination. If retro-reflective materials or devices have a marking (e.g. TOP), this marking governs the starting position. The angle of rotation ε lies in the range $-180^\circ < \varepsilon \leq 180^\circ$.

2.4 Definition of photometric terms

2.4.1 Coefficient of retro-reflection R'

Coefficient (R') obtained from the luminous intensity (I) of the retro-reflective area in the direction of observation and the illuminance (E_{\perp}) on the retro-reflective plane at right angles to the direction of the incident light and the illuminated plane sample surface A.

$$R' = \frac{I}{E_{\perp} \cdot A}$$

The coefficient of retro-reflection R' is expressed in candela per square metre per lux ($\text{cd} \cdot \text{m}^{-2} \cdot \text{lx}^{-1}$).

2.4.2 "Angular diameter of the retro-reflective sample (symbol η)", the angle subtended by the greatest dimension of the retro-reflective sample, either at the centre of the source of illumination or at the centre of the receiver.

2.4.3 "Luminance factor", the ratio of the luminance of the body considered to the luminance of a perfect diffuser under identical conditions of illumination and observation.

2.5 Fluorescence

When certain substances are brought near to a source of ultraviolet or blue radiations, they emit radiations which are nearly always of longer wavelength than those producing the effect. This phenomenon is called fluorescence. By day and in twilight, fluorescent colours are brighter than normal colours because they reflect part of the light falling upon them and in addition they emit light. At night, they are not brighter than ordinary colours.

2.6 Description of goniometer

A goniometer which can be used in making retro-reflection measurements in the CIE geometry is illustrated in Annex 1, figure 2. In this illustration, the photometer head is arbitrarily shown to be vertically above the source. The first axis is shown to be fixed and horizontal and is situated perpendicular to the observation half-plane. Any arrangement of the components which is equivalent to the one shown can be used.

2.7 Definition of "type"

SMV rear marking plates of different types means SMV marking plates which differ in such essential respects as:

- 2.7.1 The trade name or mark.
- 2.7.2 The characteristics of the retro-reflective material or devices.
- 2.7.3 The characteristics of the fluorescent material.
- 2.7.4 The parts affecting the properties of the retro-reflective material or devices.

3. APPLICATION FOR APPROVAL

3.1 The application for approval of a type of SMV rear marking plate shall be submitted by the holder of the trade name or mark, or if necessary by his duly accredited representative and shall be accompanied by:

- 3.1.1 Drawings, in triplicate, sufficiently detailed to permit identification of the type. The drawings shall show geometrically the position in which the SMV rear marking plate is to be fitted to the rear end of the vehicles. They shall also show the position intended for the approval number and the identification symbol in relation to the circle of the approval mark.
- 3.1.2 A brief description giving the technical specifications of the materials of which the retro-reflective areas are made.
- 3.1.3 A brief description giving the technical specifications of the materials of which the fluorescent area is made.
- 3.1.4 Samples of the retro-reflective and fluorescent (class 1) or retro-reflective only (class 2).

3.2 The Competent Authority shall verify the existence of satisfactory arrangements for ensuring effective control of the conformity of production before type approval is granted.

4. MARKINGS

4.1 Every SMV rear marking plate submitted for approval shall bear:

- 4.1.1 The trade name or mark of the applicant.

- 4.1.2 On the plates whose retro-reflective system is not for all angles of rotation ε , the "TOP" inscribed horizontally on the part of the plates which is intended to be the highest part of the plate when mounted on the vehicle.
- 4.2 The markings shall be applied on either the retro-reflective or the fluorescent area of the plate, or on the edge, and shall be visible from the outside when the marking plate is fitted on the vehicle.
- 4.3 The markings shall be clearly legible and shall be indelible.
5. APPROVAL
- 5.1 If the SMV rear marking plates submitted for approval in accordance with paragraph 4 above meet the requirements of this Regulation, approval for this type of SMV rear marking plate shall be granted.
- 5.2 An approval number shall be assigned to each type approved. Its first two digits (at present 01) shall indicate the series of amendments incorporating the most recent major technical amendments made to the Regulation at the time of issue of the approval. The symbol above the circle indicates the class of SMV rear marking plate, "RF" in the case of class 1 (recto-reflective and fluorescent materials) and "RR" in the case of class 2 (rectro-reflective only materials). The same Contracting Party may not assign the same number to another type of SMV rear marking plate.
- 5.3 Notice of approval or refusal or extension of approval of a type of SMV rear marking plate under this Regulation shall be communicated to the Parties to the Agreement applying this Regulation by means of a form conforming to the model in Annex 2 to this Regulation and of a drawing annexed thereto supplied by the applicant for approval, in a format not exceeding A4 (210 x 297 mm) or folded to that format and if possible on a scale of 1:1.
- 5.4 Every SMV rear marking plate conforming to a type approved under this Regulation shall bear, in addition to the markings prescribed in paragraph 4.1.
- 5.4.1 An international approval mark consisting of:

- 5.4.1.1 A circle surrounding the letter "E" followed by the distinguishing number of the country which has granted approval. 3/
- 5.4.1.2 An approval number.
- 5.5 The approval mark shall be clearly legible and shall be indelible.
- 5.6 Annex 3 to this Regulation gives an example of the arrangement of the approval mark.
6. GENERAL SPECIFICATIONS
- 6.1 SMV rear marking plates shall be so constructed that they function satisfactorily and will continue to do so in normal use. In addition, they shall not have any defect in design or manufacture that is detrimental to their efficient operation or to their maintenance in good condition.
- 6.2 The components of retro-reflective/fluorescent SMV rear marking plates (class 1) or retro-reflective only SMV rear marking plates (class 2) shall not be capable of being easily dismantled.
- 6.3 The means of attachment of the SMV rear marking plate shall be such that they allow a stable and durable connection between the plate and the rear end of vehicles, for instance by screws or rivets.

3/ 1 for Germany, 2 for France, 3 for Italy, 4 for the Netherlands, 5 for Sweden, 6 for Belgium, 7 for Hungary, 8 for the Czech Republic, 9 for Spain, 10 for Serbia, 11 for the United Kingdom, 12 for Austria, 13 for Luxembourg, 14 for Switzerland, 15 (vacant), 16 for Norway, 17 for Finland, 18 for Denmark, 19 for Romania, 20 for Poland, 21 for Portugal, 22 for the Russian Federation, 23 for Greece, 24 for Ireland, 25 for Croatia, 26 for Slovenia, 27 for Slovakia, 28 for Belarus, 29 for Estonia, 30 (vacant), 31 for Bosnia and Herzegovina, 32 for Latvia, 33 (vacant), 34 for Bulgaria, 35 (vacant), 36 for Lithuania, 37 for Turkey, 38 (vacant), 39 for Azerbaijan, 40 for The former Yugoslav Republic of Macedonia, 41 (vacant), 42 for the European Community (Approvals are granted by its Member States using their respective ECE symbol), 43 for Japan, 44 (vacant), 45 for Australia, 46 for Ukraine, 47 for South Africa, 48 for New Zealand, 49 for Cyprus, 50 for Malta, 51 for the Republic of Korea, 52 for Malaysia, 53 for Thailand, 54 and 55 (vacant), 56 for Montenegro, 57 (vacant) and 58 for Tunisia. Subsequent numbers shall be assigned to other countries in the chronological order in which they ratify or accede to the Agreement Concerning the Adoption of Uniform Technical Prescriptions for Wheeled Vehicles, Equipment and Parts which can be Fitted and/or be Used on Wheeled Vehicles and the Conditions for Reciprocal Recognition of Approvals Granted on the Basis of these Prescriptions, and the numbers thus assigned shall be communicated by the Secretary-General of the United Nations to the Contracting Parties to the Agreement.

6.4 The outer surface of the retro-reflective/fluorescent SMV rear marking plate (class 1) or retro-reflective only SMV rear marking plate (class 2) shall be easy to clean. The surface shall therefore not be rough and any protuberances it may exhibit shall not prevent easy cleaning.

7. SPECIAL SPECIFICATION (TESTS)

7.1 SMV rear marking plates shall also satisfy the conditions as to dimensions, shape, pattern and the colorimetric, photometric, physical and mechanical requirements set forth in Annexes 5 to 12 of this Regulation.

8. MODIFICATIONS AND EXTENSION OF APPROVAL OF REAR MARKING PLATES FOR SLOW-MOVING VEHICLES (BY CONSTRUCTION) AND THEIR TRAILERS

8.1 Every modification of the rear marking plate type shall be notified to the Administrative Department which granted the type approval. The department may then either:

8.1.1 Consider that the modifications made are unlikely to have appreciable adverse effects and that in any case the type of device still complies with the requirements; or

8.1.2 Require a further test report from the Technical Service responsible for conducting the tests.

8.2 Confirmation or refusal of approval, specifying the alterations, shall be notified by the procedure specified in paragraph 5.3 above to the Parties to the Agreement applying this Regulation.

8.3 The Competent Authority issuing the extension of approval shall assign a series number for such an extension and inform thereof the other Parties to the 1958 Agreement applying this Regulation by means of a communication form conforming to the model in Annex 2 to this Regulation.

9 CONFORMITY OF PRODUCTION

The conformity of production procedures shall comply with those set out in the Agreement, Appendix 2 (E/ECE/324-E/ECE/TRANS/505/Rev.2), with the following requirements:

9.1 Rear marking plates approved under this Regulation shall be so manufactured as to conform to the type approved by meeting the requirements set forth in paragraphs 6 and 7.

9.2 The minimum requirements for conformity of production control procedures set forth in Annex 13 to this Regulation shall be complied with.

9.3 The minimum requirements for sampling by an inspector set forth in Annex 14 to this Regulation shall be complied with.

9.4 The authority which has granted type approval may at any time verify the conformity control methods applied in each production facility. The normal frequency of these verifications shall be once every two years.

10. PENALTIES FOR NON-CONFORMITY OF PRODUCTION

10.1 The approval granted in respect of a type of SMV rear marking plate pursuant to this Regulation may be withdrawn if the requirements set forth above are not met or if a marking plate bearing the approval mark does not conform to the type approved.

10.2 If a Party to the Agreement applying the Regulation withdraws an approval it has previously granted, it shall forthwith so notify the other Contracting Parties applying this Regulation by means of a communication form conforming to the model in Annex 2 to this Regulation.

11. PRODUCTION DEFINITELY DISCONTINUED

If the holder of the approval completely ceases the manufacture of an SMV rear marking plate approved in accordance with this Regulation, he shall so inform the authority which granted the approval. Upon receiving the relevant communication, that authority shall inform thereof the other Parties to the Agreement applying this Regulation by means of a communication form conforming to the model in Annex 2 to this Regulation.

12. TRANSITIONAL PROVISIONS

12.1 As from the official date of entry into force of Supplement 2 to the 01 series of amendments, no Contracting Party applying this Regulation shall refuse to grant approvals under this Regulation as amended by Supplement 2 to the 01 series of amendments.

12.2 As from 24 months after the date of entry into force of Supplement 2 to the 01 series of amendments, Contracting Parties applying this Regulation shall grant approvals only if the type of rear marking plates to be approved meets the requirements of this Regulation as amended by Supplement 2 to the 01 series of amendments.

- 12.3 Contracting Parties applying this Regulation shall not refuse to grant extensions of approval to a preceding version of this Regulation, up to Supplement 1 to the 01 series of amendments.
- 12.4 Approvals granted under this Regulation earlier than 24 months after the date of entry into force of Supplement 2 to the 01 series of amendments and all extensions of approvals, including those to the preceding series of amendments granted subsequently, shall remain valid indefinitely. When the type of rear marking plates approved to a preceding version of the Regulation up to Supplement 1 to the 01 series of amendments meets the requirements of this Regulation as amended by Supplement 2 to the 01 series of amendments, the Contracting Party which granted the approval shall notify the other Contracting Parties applying this Regulation thereof.
- 12.5 No Contracting Party applying this Regulation shall refuse a type of rear marking plates approved under this Regulation as amended by Supplement 2 to the 01 series of amendments.
- 12.6 As from the official date of entry into force of Supplement 2 to the 01 series of amendments, no Contracting Party applying this Regulation shall prohibit the fitting on a vehicle of rear marking plates approved under this Regulation as amended by Supplement 2 to the 01 series of amendments.
- 12.7 Contracting Parties applying this Regulation shall continue to allow the fitting on a vehicle of rear marking plates approved under preceding version of the Regulation up to Supplement 1 to the 01 series of amendments during the 48 months period which follows the date of entry into force of Supplement 2 to the 01 series of amendments.
- 12.8 Upon the expiration of a period of 48 months after the date of entry into force of Supplement 2 to the 01 series of amendments, Contracting Parties applying this Regulation may prohibit the fitting of rear marking plates which do not meet the requirements of this Regulation as amended by Supplement 2 to the 01 series of amendments on a new vehicle for which national type or individual approval was granted more than 24 months after the entry into force of Supplement 2 to the 01 series of amendments to this Regulation.
13. NAMES AND ADDRESSES OF TECHNICAL SERVICES RESPONSIBLE FOR CONDUCTING APPROVAL TESTS, AND OF ADMINISTRATIVE DEPARTMENTS

The Parties to the Agreement applying this Regulation shall communicate to the United Nations Secretariat the names and addresses of the Technical Services responsible for conducting approval tests and of the Administrative Departments which grant approval and to which forms certifying approval or extension or refusal or withdrawal of approval, issued in other countries, are to be sent.

Annex 1

THE CIE CO-ORDINATE SYSTEM

Figure 1

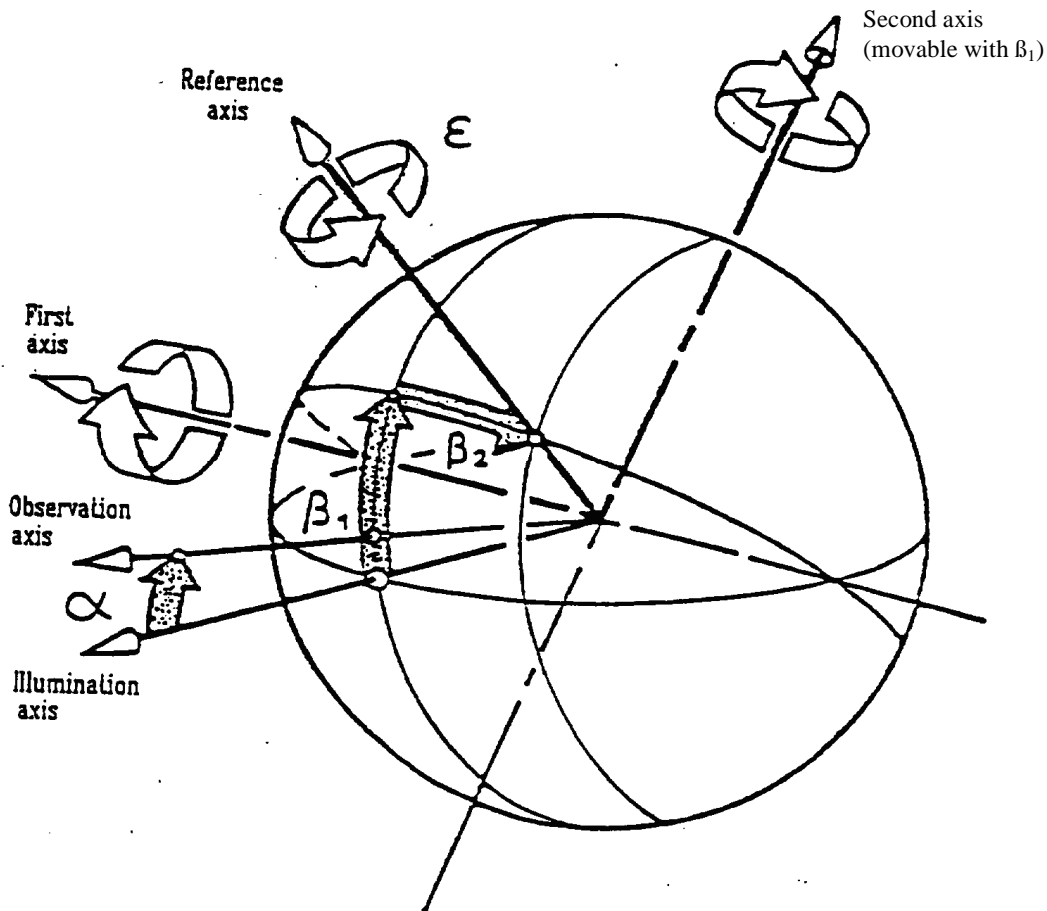

The CIE angular system for specifying and measuring retro-reflectors. The first axis is perpendicular to the plane containing the observation axis and the illumination axis. The second axis is perpendicular both to the first axis and to the reference axis. All axes, angles and directions of rotation are shown positive.

- Notes:
- (a) The principal fixed axis is the illumination axis.
 - (b) The first axis is fixed perpendicular to the plane containing the observation and illumination axis.
 - (c) The reference axis is fixed in retro-reflector and movable with β_1 and β_2 .

Figure 2

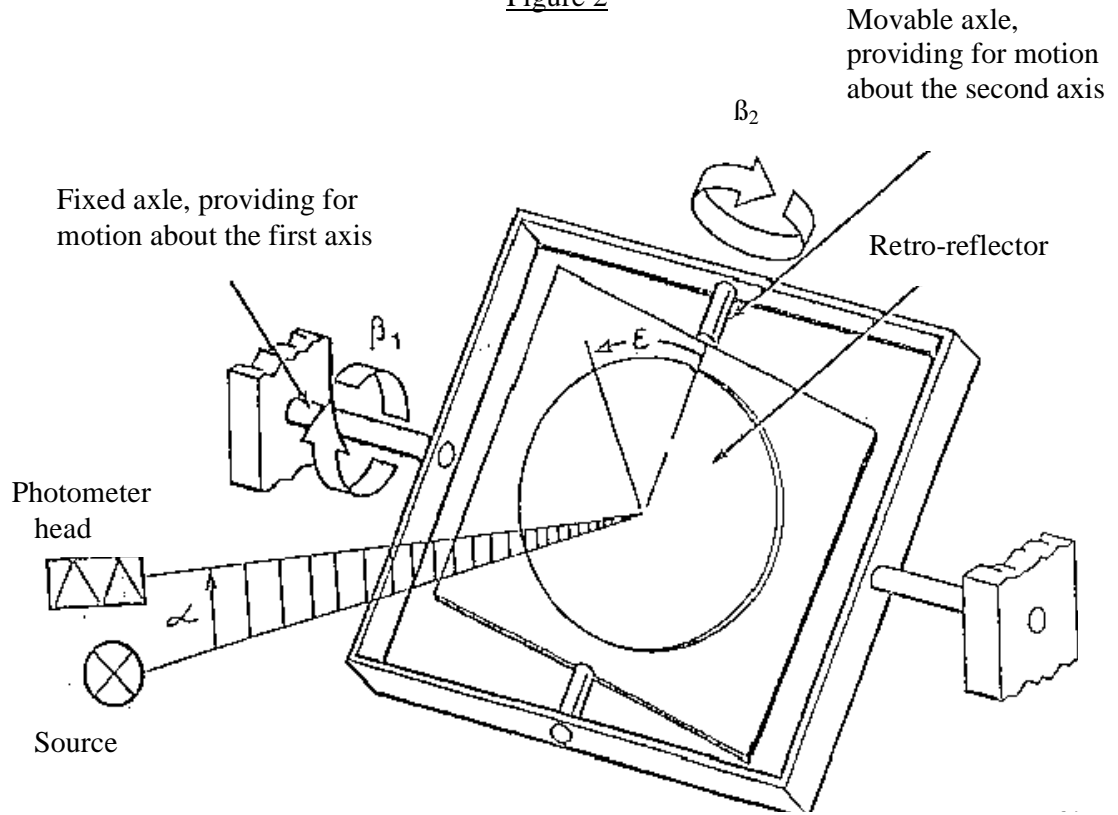

Representation of a goniometer mechanism embodying the CIE angular system for specifying and measuring retro-reflectors. All angles and directions of rotation are shown positive.

Annex 2

COMMUNICATION

(Maximum format: A4 (210 x 297 mm))

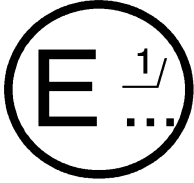

issued by :

Name of administration:

.....
.....
.....

concerning: 2/

- APPROVAL GRANTED
- APPROVAL EXTENDED
- APPROVAL REFUSED
- APPROVAL WITHDRAWN
- PRODUCTION DEFINITELY DISCONTINUED

of a type of SMV rear marking plate, pursuant to Regulation No. 69

Approval No. :

Extension No. :

1. Trade name or mark of the SMV rear marking plate:
2. SMV rear marking plate type:.....
- 2.1 SMV rear marking plate class: Class 1/class 2 2/
3. Manufacturer's name and address:
4. If applicable, name and address of manufacturer's representative:
5. Submitted for approval on:
6. Technical Service responsible for conducting approval tests:
7. Date of test report:
8. Number of test report:
9. Remarks:

10. Vehicles to which the device is intended to be fitted (if applicable):
11. Position and nature of the marking:
12. Approval granted/refused/extended/withdrawn 1/
13. Reason(s) for extension (if applicable):
14. Place:
15. Date:
16. Signature:
17. The list of documents deposited at the Administrative Service which has granted approval is annexed to this communication.

1/ Distinguishing number of the country which has granted/extended/refused/withdrawn approval (see approval provisions in the Regulation).

2/ Strike out what does not apply.

Annex 3

ARRANGEMENT OF THE APPROVAL MARK

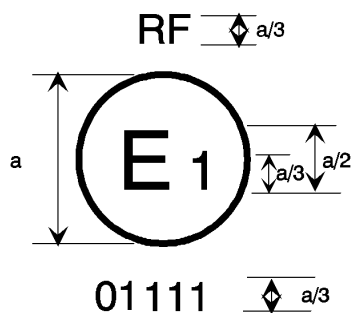

$a = 5 \text{ mm min.}$

The SMV rear marking plate bearing the above approval mark has been approved in Germany (E1) under approval number 01111. The first two digits of the approval number indicate that the approval was granted in accordance with the requirements of this Regulation as amended by the 01 series of amendments. The symbol "RF" indicates class 1 SMV rear marking plate (retro-reflective/fluorescent materials). Class 2 (retro-reflective only materials) SMV rear marking plates shall be marked by the symbol "RR".

Note: The approval number and the additional symbol must be placed close to the circle and either above or below the letter "E" or to the left or right of that letter. The digits of the approval number must be on the same side of the letter "E" and face in the same direction. The approval number and the additional symbol must be placed diametrically opposite one another. The use of Roman numerals as approval numbers should be avoided so as to prevent any confusion with other symbols.

Annex 4

TEST PROCEDURE

TEST SAMPLES

1. Five SMV rear marking plates shall be supplied to the testing laboratory for the various tests to be conducted.
2. The test samples shall be representative of current production, fabricated in accordance with the recommendations of the manufacturer(s) of the retro-reflective and fluorescent (class 1) or retro-reflective only (class 2).
3. After verification of the general specifications (paragraph 6 of the Regulation) and the specifications of shape and dimensions (Annex 5) four samples shall be subjected to the heat resistance test described in Annex 9 to this Regulation, prior to the tests described in Annexes 6, 7 and 8. The fifth sample shall be kept for reference purposes during the test procedures.
4. The photometric and colorimetric measurements may be made on the same sample.
5. For the other tests, samples which have not undergone any testing should be used.

Annex 5

SPECIFICATIONS OF SHAPE AND DIMENSIONS

SHAPE AND DIMENSIONS OF RETRO-REFLECTIVE/FLUORESCENT (CLASS 1) OR RETRO-REFLECTIVE ONLY (CLASS 2) SMV REAR MARKING PLATES

1. Shape

The plates shall be in the shape of an equilateral triangle with truncated corners, for mounting with one apex upwards at the rear of slow-moving vehicles.

2. Pattern

The SMV rear marking plates shall have a red fluorescent centre and red retro-reflective borders made of either retro-reflective sheeting or coating or of plastic corner-cube reflectors (class 1). The SMV rear marking plates of class 2 shall have a retro-reflective centre.

3. Dimensions

The length of the base of the enclosed fluorescent triangle (class 1) or retro-reflective triangle (class 2) shall be: minimum 350 mm and maximum 365 mm. The minimum width of the light-emitting surface of the red retro-reflective border shall be 45 mm, the maximum width 48 mm. These features are illustrated in the example of Annex 12.

Annex 6

COLORIMETRIC SPECIFICATIONS

1. SMV rear marking plates for slow-moving vehicles and their trailers shall be composed either of red retro-reflective and red fluorescent materials or devices (class 1) or red retro-reflective only materials or devices (class 2).

2. Red retro-reflective material or devices

2.1 When measured with a spectrophotometer in accordance with the provisions of CIE document No. 15 (1971) and illuminated with the CIE Standard Illuminant D₆₅ at an angle of 45° to the normal and viewed along the normal (45/0 geometry), the colour of the material in new condition shall be located within the area defined by the chromaticity co-ordinates in table 1 and comply with the luminance factor.

Table 1

<u>Colour</u>		<u>1</u>	<u>2</u>	<u>3</u>	<u>4</u>	<u>Luminance factor</u>
Red	x	0.690	0.595	0.560	0.650	≥ 0.03
	y	0.310	0.315	0.350	0.350	

2.2 When illuminated by the CIE Standard Illuminant A at an entrance angle $\beta_1 = \beta_2 = 0^\circ$ or, if this produces a colourless surface reflection, an angle $\beta_1 = \pm 5^\circ$, $\beta_2 = 0^\circ$, and measured at an observation angle of 20', the colour of the material in new condition shall be located within the area defined by the chromaticity co-ordinates in table 2.

Table 2

<u>Colour</u>		<u>1</u>	<u>2</u>	<u>3</u>	<u>4</u>
Red	x	0.720	0.735	0.665	0.643
	y	0.258	0.265	0.335	0.335

Note: The question of the night-time colours of retro-reflective materials is at present being studied by CIE TC 1.6; the above limits are therefore only provisional and will be revised later after CIE TC 1.6 has completed its work.

3. Red fluorescent material

3.1 When measured with a spectrophotometer in accordance with the provisions of CIE document No. 15 (1971) and illuminated polychromatically with the CIE Standard Illuminant D₆₅ at an angle 45° to the normal and viewed along the normal (geometry 45/0), the colour of the material in new condition shall be located within the area defined by the chromaticity co-ordinates in table 3 and comply with the luminance factor.

Table 3

<u>Colour</u>		<u>1</u>	<u>2</u>	<u>3</u>	<u>4</u>	<u>Luminance</u> <u>factor</u>
Red	x	0.690	0.595	0.569	0.655	≥ 0.30
	y	0.310	0.315	0.341	0.345	

4. Compliance with the colorimetric specifications shall be verified by a visual comparison test.

If any doubt remains after this test, conformity with the colorimetric specification shall be verified by determining the trichromatic co-ordinates of the most doubtful sample.

Annex 7

PHOTOMETRIC SPECIFICATIONS

Photometric properties

1. When illuminated with a CIE Standard Illuminant A and measured as recommended by CIE TC 2.3 (CIE Publication No. 54, 1982), the coefficient of retro-reflection R' in candelas per square metre per lux ($\text{cd.m}^{-2}.\text{lx}^{-1}$) of the entire red retro-reflective area in new condition shall be at least as indicated in table 1.

Table 1

Coefficient of retro-reflection R' [$\text{cd.m}^{-2}.\text{lx}^{-1}$]

Observation angle α [']	Entrance angle β [°]				
20'	β_1	0°	0°	0°	0°
	β_2	5°	20°	30°	40°
R' of the outer border (class 1, 2) [$\text{cd.m}^{-2}.\text{lx}^{-1}$]		120	60	30	10
R' of the enclosed triangle (class 2) [$\text{cd.m}^{-2}.\text{lx}^{-1}$]		10	7	4	-

2. The subtended angle at the sample shall not be larger than 80'.

Annex 8

RESISTANCE TO EXTERNAL AGENTS

1. Resistance to weathering

- 1.1 Procedure - For each test, two specimens of a sample unit (see paragraph 2.1.2 of this Regulation) are taken. One specimen shall be stored in a dark and dry container for subsequent use as "reference unexposed specimen".

The second specimen shall be subjected to a source of illumination in accordance with ISO Standard 105-B02-1978, Section 4.3.1; the retro-reflective material shall be exposed until blue standard No. 7 has faded to No. 4 on the grey scale and the fluorescent material until blue standard No. 5 has faded to No. 4 on the grey scale.

After the test, the specimen shall be washed in a dilute neutral detergent solution, dried and examined for conformity with the requirements specified in paragraphs 1.2 to 1.4.

- 1.2 Visual appearance - No area of the exposed specimen shall show any evidence of cracking, sealing, pitting, blistering, delamination, distortion, chalking, staining or corrosion.

There shall be no shrinkage in excess of 0.5 per cent in any linear direction and no evidence of adhesion failure such as edge lifting from the substrate.

- 1.3 Colour fastness - The colours of the exposed specimen shall still meet the requirements in Annex 6, tables 1, 2 and 3.

- 1.4 Effect on the coefficient of luminous intensity of the retro-reflective material.

- 1.4.1 For this check, measurement shall be made only at an observation angle of 20' and an entrance angle of 5° by the method given in Annex 7.

- 1.4.2 The coefficient of luminous intensity of the exposed specimen when dry shall be not less than 80 per cent of the value in Annex 7, table 1.

- 1.4.3 The specimen shall then be subjected to simulated rainfall and its coefficient of luminous intensity under this condition shall be not less than 90 per cent of the value obtained when measured in dry condition, as explained in paragraph 1.4.2 above.

2. Resistance to corrosion (ISO Standard 3768)

- 2.1 A specimen of the sample unit shall be subjected to the action of a saline mist for 48 hours comprising two periods of exposure of 24 hours each, separated by an interval of 2 hours during which the specimen is allowed to dry.

The saline mist shall be produced by atomizing at a temperature of $35 \pm 2^{\circ}\text{C}$ of a saline solution obtained by dissolving five parts by weight of sodium chloride in 95 parts of distilled water containing not more than 0.02 per cent of impurities.

- 2.2 Immediately after completion of the test, the sample shall show no sign of corrosion liable to impair the efficiency of the device.

- 2.2.1 The coefficient of luminous intensity R of the retro-reflective area, when measured after a recovery period of 48 hours as specified in Annex 7, paragraph 1, at an entrance angle of 5° and an observation angle of 20° , shall be not less than the value in Annex 7, table 1. Before measuring, the surface shall be cleaned to remove salt deposits from the saline mist.

3. Resistance to fuels

A section of a sample unit not less than 300 mm long shall be immersed in a mixture of n-heptane and toluol, 70 per cent and 30 per cent by volume, for one minute.

After removal, the surface shall be wiped dry with a soft cloth and shall not show any visible change which would reduce its effective performance.

4. Bonding strength (in the case of adhesive materials)

- 4.1. The adhesion of retro-reflective materials shall be determined after 24 hours curing time by utilizing a 90-degree peel on a tensile strength testing machine.

- 4.2 The adhesion of laminated or coated retro-reflective and fluorescent materials shall be determined.

- 4.3 The coated materials, of whatever kind, shall not be removable without tools or without damaging the material.

- 4.4 The laminated materials (adhesive films) shall need a force of at least 10 N per 25 mm width at a speed of 300 mm per minute, to be removed from the substrate.

5. Resistance to water

A section of a sample unit not less than 300 mm long shall be immersed in distilled water at a temperature of $23 \pm 5^{\circ}\text{C}$ for a period of 18 hours; it shall then be left to dry for 24 hours under normal laboratory conditions.

After completion of the test, the section shall be examined. No part inside 10 mm from the cut edge shall show evidence of deterioration which would reduce the effectiveness of the plate.

6. Resistance to impact (except for plastics corner-cube reflectors)

When a 25 mm diameter solid steel ball is dropped from a height of 2 m on to the retro-reflective and on the fluorescent surfaces of a supported plate, at an ambient temperature of $23 \pm 2^{\circ}\text{C}$, the materials shall show no cracking or separation from the substrate at a distance of more than 5 mm from the impacted area.

7. Resistance to cleaning

7.1 Manual cleaning

7.1.1 A test sample smeared with a mixture of detergent lubricating oil and graphite shall be easily cleaned without damage to the retro-reflective surface or fluorescent surface when wiped with a mild aliphatic solvent such as n-heptane, followed by washing with a neutral detergent.

7.2. Power washing

7.2.1. When subjected to a continuous spraying action for 60 seconds on the test component in its normal mounting conditions, a test sample shall show no damage to the retro-reflective surface or delamination from the substrate or separation from the sample mounting surface under the following set-up parameters:

- (a) Water/wash solution pressure 8 ± 0.2 MPa;
- (b) Water/wash solution temperature $60^{\circ} - 5^{\circ}\text{C}$;
- (c) Water/wash solution flow rate 7 ± 1 l/min;
- (d) The tip of the cleaning wand to be positioned at distance of 600 ± 20 mm away from the retro-reflective surface;
- (e) Cleaning wand to be held at no greater angle than 45 degrees from perpendicular to the retro-reflective surface;
- (f) 40 degree nozzle creating wide fan pattern.

Annex 9

RESISTANCE TO HEAT

1. The four samples shall be kept for 48/hours in a dry atmosphere at a temperature of $65 \pm 2^{\circ}\text{C}$, after which the samples shall be allowed to cool for 1 hour at $23 \pm 2^{\circ}\text{C}$. They shall then be kept for 12 hours at a temperature of $-20 \pm 2^{\circ}\text{C}$.
- 1.1 The sample shall be examined after a recovery time of 4 hours under normal laboratory conditions.
2. After this test, no cracking or appreciable distortion of the surfaces, particularly of the optical units, shall be evident.

Annex 10

RIGIDITY OF THE PLATES

The triangular plate shall be strongly held on one of its long sides, with the clamps of the holding device not encroaching over more than 20 mm. A force of 10N perpendicular to the plane shall be applied to the opposite apex.

The apex shall then not move in the direction of the force by more than 40 mm.

After removal of the force, the plate shall visibly return to its initial position. The residual deflection shall not be more than 5 mm.

Annex 11

STABILITY IN TIME OF THE OPTICAL PROPERTIES 1/ OF REAR MARKING PLATES

1. The authority which granted approval shall have the right to check the stability in time of the optical properties of a type of rear marking plate in service.
2. The Competent Authorities of countries other than the country in which approval was granted may carry out similar checks in their territory. If a type of rear marking plate in use exhibits a systematic defect, the said authorities shall transmit to the authority which granted approval, with a request for its opinion, any components removed for examination.
3. In the absence of other criteria, the concept of "systematic defect" of a type of rear marking plate in use shall be interpreted in conformity with the intention of paragraph 6.1. of this Regulation.

1/ Despite the importance of tests to check the stability in time of the optical properties of rear marking plates, it is in the present state of the art not yet possible to assess this stability by laboratory tests of limited duration.

Annex 12

REAR MARKING PLATES FOR SLOW-MOVING VEHICLES
AND THEIR TRAILERS

Example

All dimensions in mm

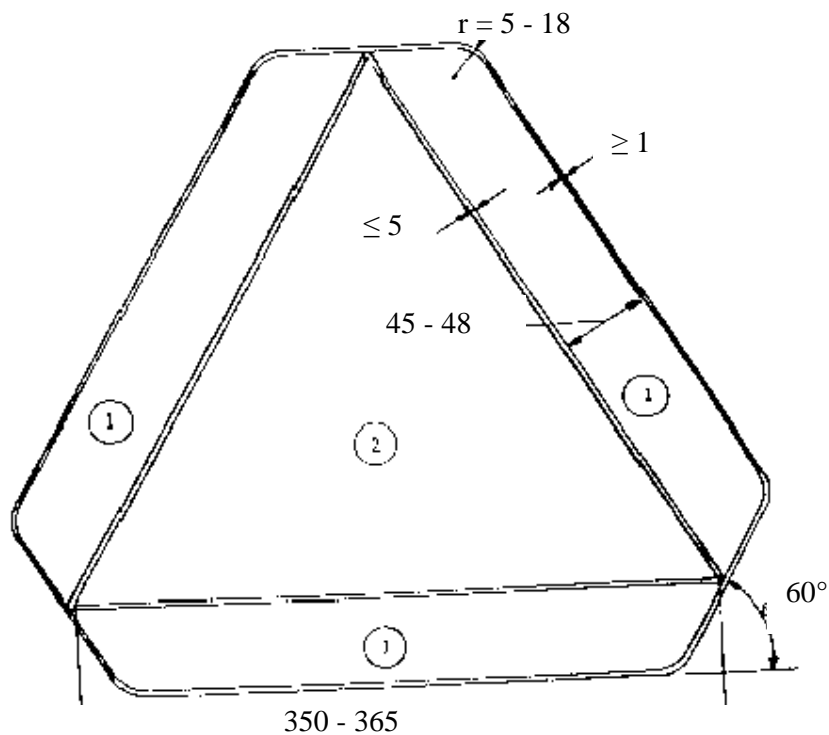

- (1) Red retro-reflecting material or corner-cube retro-reflector (class 1 or class 2)
- (2) Red fluorescent material (class 1) or red retro-reflecting material (class 2)

Annex 13

MINIMUM REQUIREMENTS FOR CONFORMITY OF PRODUCTION
CONTROL PROCEDURES

1. GENERAL

- 1.1 The conformity requirements shall be considered satisfied from a mechanical and geometric standpoint, if the differences do not exceed inevitable manufacturing deviations within the requirements of this Regulation.
- 1.2 With respect to photometric performances, the conformity of mass-produced rear marking plates shall not be contested if, when testing photometric performances of any rear marking plate chosen at random, no measured value deviates unfavourably by more than 20 per cent from the values prescribed in this Regulation.
- 1.3 The chromaticity coordinates shall be complied with.

2. MINIMUM REQUIREMENTS FOR VERIFICATION OF CONFORMITY BY THE MANUFACTURER

For each type of rear marking plate the holder of the approval mark shall carry out at least the following tests, at appropriate intervals. The tests shall be carried out in accordance with the provisions of this Regulation.

If any sampling shows non-conformity with regard to the type of test concerned, further samples shall be taken and tested. The manufacturer shall take steps to ensure the conformity of the production concerned.

2.1 Nature of tests

Tests of conformity in this Regulation shall cover the photometric and colorimetric characteristics and the test of weather resistance of these characteristics.

2.2 Methods used in tests

- 2.2.1 Tests shall generally be carried out in accordance with the methods set out in this Regulation.

- 2.2.2 In any test of conformity carried out by the manufacturer, equivalent methods may be used with the consent of the competent authority responsible for approval tests. The manufacturer is responsible for proving that the applied methods are equivalent to those laid down in this Regulation.

2.2.3 The application of paragraphs 2.2.1 and 2.2.2 requires regular calibration of test apparatus and its correlation with measurements made by a competent authority.

2.2.4 In all cases the reference methods shall be those of this Regulation, particularly for the purpose of administrative verification and sampling.

2.3 Nature of sampling

Samples of rear marking plates shall be selected at random from the production of a uniform batch. A uniform batch means a set of rear marking plates of the same type, defined according to the production methods of the manufacturer.

The assessment shall in general cover series production from individual factories. However, a manufacturer may group together records concerning the same type from several factories, provided these operate under the same quality system and quality management.

2.4 Measured and recorded photometric characteristics

The sampled rear marking plate shall be subjected to photometric measurements for minimum values at the points and chromaticity coordinates provided for in the Regulation.

2.5 Criteria governing acceptability

The manufacturer is responsible for carrying out a statistical study of the test results and for defining, in agreement with the Competent Authority, criteria governing the acceptability of his products in order to meet the specifications laid down for verification of conformity of products in paragraph 9.1 of this Regulation.

The criteria governing the acceptability shall be such that, with a confidence level of 95 per cent, the minimum probability of passing a spot check in accordance with Annex 14 (first sampling) would be 0.95.

Annex 14

MINIMUM REQUIREMENTS FOR SAMPLING BY AN INSPECTOR

1. GENERAL

- 1.1. The conformity requirements shall be considered satisfied from a mechanical and a geometric standpoint, in accordance with the requirements of this Regulation, if any, if the differences do not exceed inevitable manufacturing deviations.
- 1.2. With respect to photometric performance, the conformity of mass-produced rear marking plates shall not be contested if, when testing photometric performances of any rear marking plate chosen at random:
 - 1.2.1. no measured value deviates unfavourably by more than 20 per cent from the values prescribed in this Regulation.
 - 1.2.2. Rear marking plates with apparent defects are disregarded.
- 1.3. The chromaticity coordinates shall be complied with.

2. FIRST SAMPLING

In the first sampling four rear marking plates are selected at random. The first sample of two is marked A, the second sample of two is marked B.

2.1. The conformity is not contested

- 2.1.1. Following the sampling procedure shown in Figure 1 of this annex the conformity of mass-produced rear marking plates shall not be contested if the deviation of the measured values of the rear marking plates in the unfavourable directions are:

2.1.1.1. sample A

A1: one rear marking plate	0 per cent
one rear marking plate not more than	20 per cent
A2: both rear marking plates more than	0 per cent
but not more than	20 per cent
go to sample B	

2.1.1.2. sample B

B1: both rear marking plates 0 per cent

2.2. The conformity is contested

2.2.1. Following the sampling procedure shown in Figure 1 of this annex the conformity of mass-produced rear marking plates shall be contested and the manufacturer requested to make his production meet the requirements (alignment) if the deviations of the measured values of the rear marking plates are:

2.2.1.1. sample A

A3: one rear marking plate not more than 20 per cent
 one rear marking plate more than 20 per cent
 but not more than 30 per cent

2.2.1.2 sample B

B2: in the case of A2
 one rear marking plate more than 0 per cent
 but not more than 20 per cent
 one rear marking plate not more than 20 per cent

B3: in the case of A2
 one rear marking plate 0 per cent
 one rear marking plate more than 20 per cent
 but not more than 30 per cent

2.3. Approval withdrawn

Conformity shall be contested and paragraph 10 applied if, following the sampling procedure in Figure 1 of this annex, the deviations of the measured values of the rear marking plates are:

2.3.1. sample A

A4: one rear marking plate not more than 20 per cent
 one rear marking plate more than 30 per cent

A5: both rear marking plates more than 20 per cent

2.3.2. sample B

B4:	in the case of A2	
	one rear marking plate more than	0 per cent
	but not more than	20 per cent
	one rear marking plate more than	20 per cent
B5:	in the case of A2	
	both rear marking plates more than	20 per cent
B6:	in the case of A2	
	one rear marking plate	0 per cent
	one rear marking plate more than	30 per cent

3. REPEATED SAMPLING

In the cases of A3, B2, B3 a repeated sampling, third sample C of two rear marking plates and fourth sample D of two rear marking plates, selected from stock manufactured after alignment, is necessary within two months time after the notification.

3.1. The conformity is not contested

3.1.1. Following the sampling procedure shown in Figure 1 of this annex the conformity of mass-produced rear marking plates shall not be contested if the deviations of the measured values of the rear marking plates are:

3.1.1.1. sample C

C1:	one rear marking plate	0 per cent
	one rear marking plate not more than	20 per cent
C2:	both rear marking plates more than	0 per cent
	but not more than	20 per cent
	go to sample D	

3.1.1.2. sample D

D1:	in the case of C2	
	both rear marking plates	0 per cent

3.2. The conformity is contested

3.2.1. Following the sampling procedure shown in Figure 1 of this annex the conformity of mass-produced rear marking plates shall be contested and the manufacturer requested to make his production meet the requirements (alignment) if the deviations of the measured values of the rear marking plates are:

3.2.1.1. sample D

D2: in the case of C2	
one rear marking plate more than	0 per cent
but not more than	20 per cent
one rear marking plate not more than	20 per cent

3.3. Approval withdrawn

Conformity shall be contested and paragraph 10 applied if, following the sampling procedure in Figure 1 of this annex, the deviations of the measured values of the rear marking plates are:

3.3.1. sample C

C3: one rear marking plate not more than	20 per cent
one rear marking plate more than	20 per cent
C4: both rear marking plates more than	20 per cent

3.3.2. sample D

D3: in the case of C2	
one rear marking plate 0 or more than	0 per cent
one rear marking plate more than	20 per cent

4. RESISTANCE TESTS

Specimens of one of the rear marking plates of sample A, after sampling procedure in Figure 1 of this annex, shall be tested according to the procedures described in Annexes 8 and 9 to this Regulation.

The rear marking plate shall be considered acceptable if the tests were passed. However, if the tests on specimens of sample A did not pass the tests, the two rear marking plates of sample B shall be subjected to the same procedure and both shall pass the test.

Figure 1

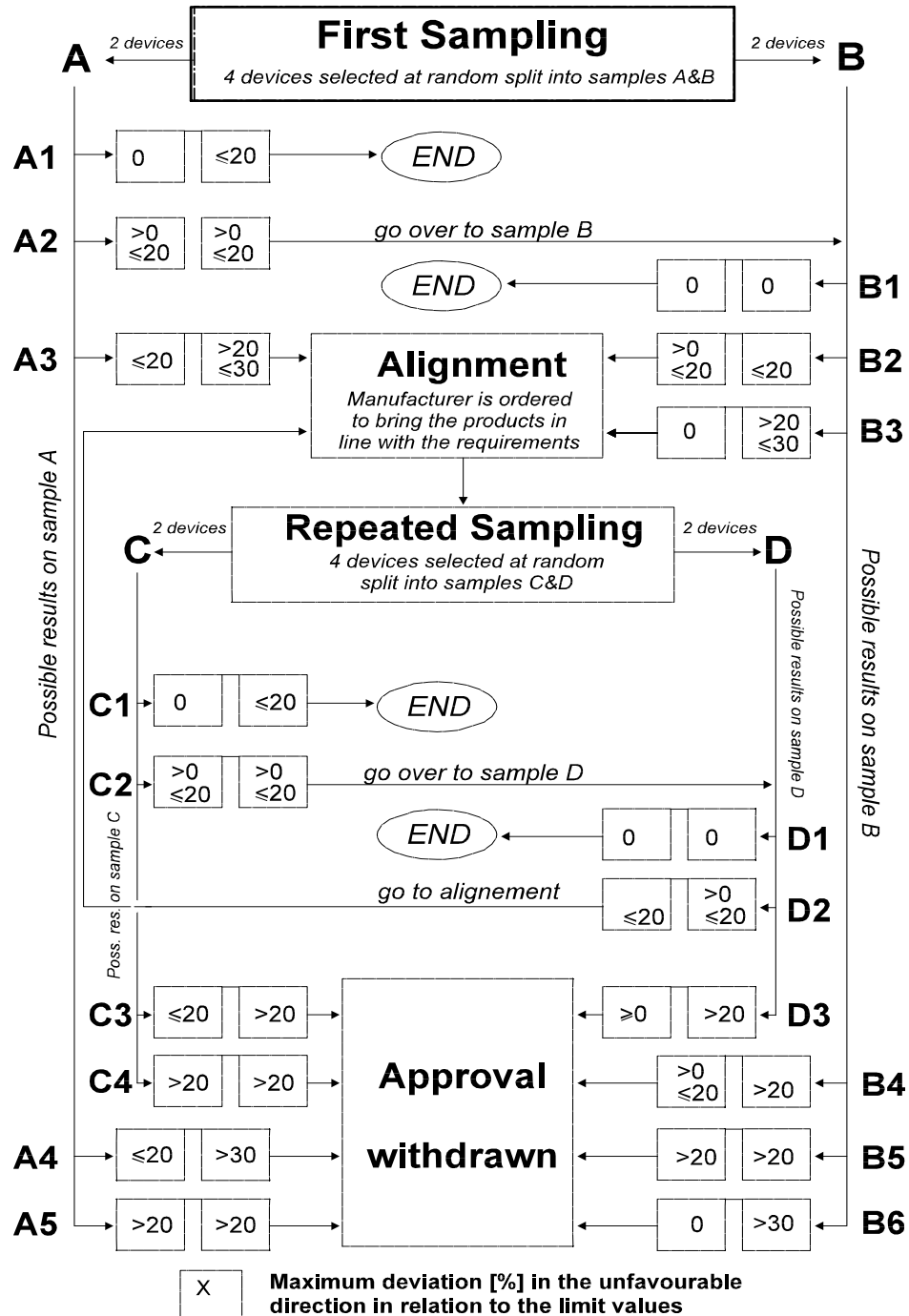

Annex 15

GUIDELINES FOR INSTALLATION OF REAR MARKING PLATES ON SLOW-MOVING VEHICLES (BY CONSTRUCTION) AND THEIR TRAILERS

1. It is recommended to the Governments to require on slow-moving vehicles which, by construction, cannot travel faster than 30 km/h, "Rear marking plates for slow-moving vehicles and their trailers" conforming to this Regulation and the specific requirements relating to its scope in accordance with the guidelines given in this annex.

2. Scope

The main purpose of these guidelines is to establish requirements for installation, arrangement, position and geometric visibility of rear marking plates on slow-moving vehicles and their trailers which, by construction, cannot travel faster than 30 km/h. It increases the visibility and permits an easy identification of these vehicles.

3. Number

At least one.

4. Arrangement

The rear marking plate(s) shall be type approved and meet the requirements of this Regulation.

The apex of a rear marking plate shall be directed upwards.

Every part of a rear marking plate shall lie within 5° of a transverse vertical plane at right angles to the longitudinal axis of the vehicle and shall face to the rear.

5. Position

In width: If there is only one rear marking plate, it must be on the opposite side of the median longitudinal plane of the vehicle to the direction of traffic prescribed in the country of registration.

In height: Above the ground, not less than 250 mm (lower edge), not more than 1,500 mm (upper edge).

In length: At the rear of the vehicle.

6. Geometric visibility

Horizontal angle : 30° inwards and outwards, covering by indispensable
constructional parts of the vehicle up to 10 per cent of the rear
marking plate surface is permitted;

Vertical angle : 15° above and below the horizontal;

Orientation : rearwards.
