

9 November 2010

Agreement

Concerning the Adoption of Uniform Technical Prescriptions for Wheeled Vehicles, Equipment and Parts which can be Fitted and/or be Used on Wheeled Vehicles and the Conditions for Reciprocal Recognition of Approvals Granted on the Basis of these Prescriptions*

(Revision 2, including the amendments which entered into force on 16 October 1995)

Addendum 63: Regulation No. 64

Revision 1

Incorporating:

Supplement 1 to the original version of the Regulation - Date of entry into force:
17 September 1989

Supplement 2 to the original version of the Regulation - Date of entry into force:
30 October 2003

01 series of amendments: Date of entry into force: 3 February 2008

Corrigendum 1 to the 01 series of amendments, subject of Depository Notification
C.N.1161.2007.TREATIES-2 dated 18 January 2008 - Date of entry into force:
3 February 2008

02 series of amendments – Date of entry into force: 19 August 2010

Corrigendum 1 to the 02 series of amendments, subject of Depository Notification
C.N.466.2010.TREATIES-2 dated 30 July 2010 - Date of entry into force: 19 August 2010

Uniform provisions concerning the approval of vehicles with regard to their equipment which may include: a temporary-use spare unit, run-flat tyres and/or a run-flat system, and/or a tyre pressure monitoring system



NATIONS UNIES

* Former title of the Agreement: Agreement Concerning the Adoption of Uniform Conditions of Approval and Reciprocal Recognition of Approval for Motor Vehicle Equipment and Parts, done at Geneva on 20 March 1958.

Regulation No. 64

Uniform provisions concerning the approval of vehicles with regard to their equipment which may include: a temporary-use spare unit, run-flat tyres and/or a run-flat system, and/or a tyre pressure monitoring system

Contents

	<i>Page</i>
1. Scope	4
2. Definitions	4
3. Application for approval	7
4. Approval	7
5. Specifications and tests	9
6. Supplementary information	13
7. Modifications and extension of approval of the vehicle type	14
8. Conformity of production	15
9. Penalties for non-conformity of production	15
10. Production definitely discontinued	15
11. Names and addresses of Technical Services responsible for conducting approval tests, and of Administrative Departments	15
12. Transitional provisions	15
Annexes	
1. Communication concerning the approval (or refusal or extension or withdraw of approval or production definitely discontinued) of a vehicle type with regard to its equipment with temporary-use unit, pursuant to Regulation No. 64	17
2. Arrangements of approval marks	19
3. Braking and deviation test for vehicles fitted with temporary-use spare units	21
4. Test requirements for Run-Flat Warning System (RFWS)	23
5. Test requirements for Tyre Pressure Monitoring Systems (TPMS)	25

1. Scope

1. This Regulation applies to the approval of vehicles of category M₁ and N₁¹ when equipped with:
 - (a) A temporary use spare unit; and/or
 - (b) Run-flat tyres and/or a run-flat system; and/or
 - (c) A tyre pressure monitoring system².

For the purposes of this Regulation, spare wheel and tyre substitute units in the form of run-flat tyres or a run-flat system in a totally deflated condition, are to be treated as being temporary-use spare units as defined in paragraph 2.10. of the Regulation.

2. Definitions

For the purposes of this Regulation.

- 2.1. "*Approval of a vehicle*" means the approval of a vehicle type with regard to its temporary-use spare wheel and tyre unit.
- 2.2. "*Vehicle type*" means a category of vehicles which do not differ significantly in such essential aspects as:
 - 2.2.1. "*Vehicle type with regard to its temporary-use spare unit*":
 - 2.2.1.1. The maximum axle loads of the vehicle, as defined in paragraph 2.10;
 - 2.2.1.2. The characteristics of the temporary-use spare wheel and tyre unit;
 - 2.2.1.3. The method of drive (front wheel, rear wheel, four wheels);
 - 2.2.1.4. The suspension;
 - 2.2.1.5. The braking system;
 - 2.2.1.6. The wheel size/tyre size;
 - 2.2.1.7. The wheel offset.
 - 2.2.2. "*Vehicle type with regard to its tyre pressure monitoring system*":
 - 2.2.2.1. The manufacturer's trade name or mark;
 - 2.2.2.2. Vehicle features which significantly influence the performances of the tyre pressure monitoring system;
 - 2.2.2.3. The type and design of the tyre pressure monitoring system.
- 2.3. "*Wheel*" means a complete wheel consisting of a rim and a wheel disc;
 - 2.3.1. "*Wheel size designation*" means a designation comprising at least the nominal rim diameter, the nominal rim width and the rim profile;

¹ As defined in Annex 7 of the Consolidated Resolution on the Construction of Vehicles (R.E.3) (TRANS/WP.29/78/Rev.1/Amend.2, as last amended by Amend.4).

² In the case of vehicles of categories M₁ up to a maximum mass of 3,500 kg and N₁, in both cases with all axles equipped with single tyres.

- 2.3.2. "Wheel offset" means the distance from the hub abutment face to the centre line of the rim.
- 2.4. "Tyre" means a pneumatic tyre, being a reinforced flexible envelope that is provided with, or forms in conjunction with the wheel on which it is mounted, a continuous, essentially toroidal, closed chamber containing a gas (usually air) or a gas and liquid, that is intended normally to be used at a pressure greater than atmospheric pressure. It may be a:
- 2.4.1. "Normal tyre" being a tyre that is suitable for all normal, on-road, conditions of use;
- 2.4.2. "Temporary-use spare tyre" being a tyre that is specifically designed to be different from a normal tyre and intended only for temporary-use under restricted driving conditions;
- 2.4.3. "Run-flat tyre" or "Self supporting tyre" describes a pneumatic tyre structure provided with any technical solutions (for example, reinforced sidewalls, etc.) allowing the pneumatic tyre, mounted on the appropriate wheel and in the absence of any supplementary component, to supply the vehicle with the basic tyre functions, at least, at a speed of 80 km/h (50 mph) and a distance of 80 km when operating in flat tyre running mode;
- 2.4.4. "Run-flat system" or "Extended mobility system" describes an assembly of specified functionally dependant components, including a tyre, which together provide the specified performance granting the vehicle with the basic tyre functions, at least, at a speed of 80 km/h (50 mph) and a distance of 80 km when operating in flat tyre running mode.
- 2.5. "Flat tyre running mode" describes the state of tyre, essentially maintaining its structural integrity, while operating at an inflation pressure between 0 and 70 kPa.
- 2.6. "Basic tyre function" means the normal capability of an inflated tyre in supporting a given load up to a given speed and transmitting the driving, the steering and the braking forces to the ground on which it runs.
- 2.7. "Tyre size designation" means a combination of figures that uniquely identify the geometric size of the tyre, comprising the nominal section width, the nominal aspect ratio and the nominal diameter. Precise definitions of these features may be found in Regulation No. 30.
- 2.8. "Tyre structure" means the technical characteristics of the tyre's carcass. This may be bias ply (diagonal or cross ply), bias-belted, radial ply or run-flat tyre as further defined in Regulation No. 30.
- 2.9. "Standard spare unit" means an assembly of a wheel and tyre identical in terms of wheel and tyre size designations, wheel offset and tyre structure to that fitted in the same axle position and to the particular model or version of the vehicle for normal operation. It includes the case of a wheel that is produced from a different material, for example, steel instead of aluminium alloy, that may use different wheel fixing nut or bolt designs but which is otherwise identical to the wheel intended for normal operation.
- 2.10. "Temporary-use spare unit" means an assembly of any wheel and tyre that is not within that defined as a "Standard spare unit" in paragraph 2.9. Temporary-use spare units may be of the following types:

- 2.10.1. *Type 1*
An assembly in which the tyre is a temporary-use spare tyre as defined in paragraph 2.4.2.;
- 2.10.2. *Type 2*
An assembly in which the wheel has a different offset from that of the wheel fitted in the same axle position for normal operation of the vehicle;
- 2.10.3. *Type 3*
An assembly in which the tyre is of a different structure from that fitted in the same axle position for normal operation of the vehicle;
- 2.10.4. *Type 4*
An assembly in which the tyre is a normal tyre as defined in paragraph 2.4.1. but where the size designation of the wheel or the tyre or both, differ from those of the wheel or tyre fitted in the same axle position for normal operation of the vehicle;
- 2.10.5. *Type 5*
An assembly in which a wheel and tyre unit as defined in paragraph 2.4.3. or 2.4.4. is fitted to the vehicle for normal, long term road use, but used in an emergency in a totally deflated condition.
- 2.11. "*Maximum mass*" means the maximum value of the vehicle stated by the manufacturer to be technically permissible (this mass may be higher than the "permissible maximum mass" laid down by the national administration).
- 2.12. "*Maximum axle load*" means the maximum value, as indicated by the manufacturer, of the total vertical force between the contact surfaces of the tyres or tracks of one axle and the ground and resulting from the part of the vehicle mass supported by that axle; this load may be higher than the "authorized axle load" laid down by the national administration. The sum of the axle loads may be greater than the value corresponding to the total mass of the vehicle.
- 2.13. "*Run-Flat Warning System*" describes a system which delivers information to the driver that a tyre is operating in the flat tyre running mode.
- 2.14. "*Tyre Pressure Monitoring System (TPMS)*" means a system fitted on a vehicle, able to perform a function to evaluate the inflation pressure of the tyres or the variation of this inflation pressure over time and to transmit corresponding information to the user while the vehicle is running.
- 2.15. "*Cold tyre inflation pressure*" means the tyre pressure at ambient temperature, in the absence of any pressure build-up due to tyre usage.
- 2.16. "*Recommended cold inflation pressure (P_{rec})*" means the pressure recommended for each tyre position by the vehicle manufacturer, for the intended service conditions (e.g. speed and load) of the given vehicle, as defined on the vehicle placard and/or the vehicle owner's manual.
- 2.17. "*In service operating pressure (P_{warm})*" means the inflation pressure for each tyre position elevated from the cold pressure (P_{rec}) by temperature effects during vehicle usage.
- 2.18. "*Test Pressure (P_{test})*" means the actual pressure of the tyre(s) selected for each tyre position after deflation during the test procedure.

- 2.19. "Type of Tyre Pressure Monitoring System" means systems which do not differ significantly in such essential aspects as:
- (a) The principle of operation;
 - (b) Any components which are likely to have a significant influence on the performance of the system as specified under paragraph 5.3 to this Regulation.

3. Application for approval

- 3.1. The application for approval of a vehicle type with regard to its equipment with:
- (a) A temporary-use spare unit (including, where applicable, a run-flat warning system); and/or
 - (b) A tyre pressure monitoring system;
- shall be submitted by the vehicle manufacturer or by his duly accredited representative;
- 3.2. It shall be accompanied, in triplicate, by a description of the vehicle type with regard to the items specified in Annex 1 to this Regulation:
- 3.3. A vehicle representative of the vehicle type to be approved shall be submitted to the type Approval Authority or the Technical Service responsible for conducting the approval tests.
- 3.4. The Administrative Department shall verify the existence of satisfactory arrangements for ensuring effective control of the conformity of production before type approval is granted.

4. Approval

- 4.1. If the vehicle submitted for approval pursuant to this Regulation meets all the requirements of paragraph 5. below, approval of that vehicle type shall be granted.
- 4.1.1. A vehicle approval with respect to the provisions relating to temporary-use spare unit only shall be granted if the vehicle meets the requirements of paragraphs 5.1. and 5.2.
- 4.1.2. A vehicle approval with respect solely to the provisions relating to tyre pressure monitoring systems only shall be granted if the vehicle meets the requirements of paragraph 5.3.
- 4.2. An approval number shall be assigned to each type approved. Its first two digits (at present 02 corresponding to the 02 series of amendments) shall indicate the series of amendments incorporating the most recent major technical amendments made to the Regulation at the time of issue of the approval. The same Contracting Party may not assign the same number to another type of vehicle. However, variants of a model range which are in separate categories with respect to the criteria of paragraph 2.2. may be covered by the same type approval, provided that the results of the tests described in paragraphs 5.2. and 5.3. do not show major differences.

- 4.3. Notice of approval or of extension or of refusal of approval of a vehicle type pursuant to this Regulation shall be communicated to the Parties to the Agreement which apply this Regulation by means of a form conforming to the model in Annex 1 to this Regulation.
- 4.4. There shall be affixed, conspicuously and in a readily accessible place specified on the approval form, to every vehicle conforming to a vehicle type approved under this Regulation an international approval mark consisting of:
 - 4.4.1. A circle surrounding the letter "E" followed by the distinguishing number of the country which granted approval³;
 - 4.4.2. The number of this Regulation, followed by:
 - 4.4.2.1. The letter "R" in the case of vehicles approved in accordance with paragraph 4.1.1. only;
 - 4.4.2.2. The letter "P" in the case of vehicles approved in accordance with paragraph 4.1.2. only;
 - 4.4.2.3. The letters "RP" in the case of vehicles approved in accordance with both paragraphs 4.1.1. and 4.1.2.;
 - 4.4.3. A dash and the approval number to the right of the markings prescribed in paragraphs 4.4.1. and 4.4.2.
- 4.5. If the vehicle conforms to a vehicle type approved, under one or more Regulations annexed to the Agreement, in the country which granted approval under this Regulation, the symbol prescribed in paragraph 4.4.1. need not be repeated; in such a case, the Regulation and approval numbers and the additional symbols for all the Regulations under which approval has been granted in the country which granted approval under this Regulation shall be placed in vertical columns to the right of the symbol prescribed in paragraph 4.4.1.
- 4.6. The approval mark shall be clearly legible and be indelible.
- 4.7. The approval mark shall be placed close to or on the vehicle data plate affixed by the manufacturer.
- 4.8. Annex 2 to this Regulation gives examples of approval marks.

³ 1 for Germany, 2 for France, 3 for Italy, 4 for the Netherlands, 5 for Sweden, 6 for Belgium, 7 for Hungary, 8 for the Czech Republic, 9 for Spain, 10 for Serbia, 11 for the United Kingdom, 12 for Austria, 13 for Luxembourg, 14 for Switzerland, 15 (vacant), 16 for Norway, 17 for Finland, 18 for Denmark, 19 for Romania, 20 for Poland, 21 for Portugal, 22 for the Russian Federation, 23 for Greece, 24 for Ireland, 25 for Croatia, 26 for Slovenia, 27 for Slovakia, 28 for Belarus, 29 for Estonia, 30 (vacant), 31 for Bosnia and Herzegovina, 32 for Latvia, 33 (vacant), 34 for Bulgaria, 35 (vacant), 36 for Lithuania, 37 for Turkey, 38 (vacant), 39 for Azerbaijan, 40 for The former Yugoslav Republic of Macedonia, 41 (vacant), 42 for the European Union (Approvals are granted by its Member States using their respective ECE symbol), 43 for Japan, 44 (vacant), 45 for Australia, 46 for Ukraine, 47 for South Africa, 48 for New Zealand, 49 for Cyprus, 50 for Malta, 51 for the Republic of Korea, 52 for Malaysia, 53 for Thailand, 54 and 55 (vacant), 56 for Montenegro, 57 (vacant) and 58 for Tunisia. Subsequent numbers shall be assigned to other countries in the chronological order in which they ratify or accede to the Agreement Concerning the Adoption of Uniform Technical Prescriptions for Wheeled Vehicles, Equipment and Parts which can be Fitted and/or be Used on Wheeled Vehicles and the Conditions for Reciprocal Recognition of Approvals Granted on the Basis of these Prescriptions, and the numbers thus assigned shall be communicated by the Secretary-General of the United Nations to the Contracting Parties to the Agreement.

5. Specifications and tests

5.1. General

- 5.1.1. Tyres intended for use as part of a temporary-use spare unit as defined in paragraph 2.10., shall be approved in accordance with Regulation No. 30.
- 5.1.2. For vehicles having at least four wheels, the load capacity of the temporary-use spare unit shall be at least equal to one half of the highest of the maximum axle loads of the vehicle; if its use is restricted to a specific axle mentioned in the instructions in paragraph 6. below, its load capacity shall be at least equal to one half of the maximum load of that axle.
- 5.1.3. The design speed of the temporary-use spare unit shall be at least 120 km/h for types 1, 2 and 3.
- 5.1.4. The temporary-use spare unit shall exhibit the following characteristics:
- 5.1.4.1. An 80 km/h maximum speed warning symbol arranged in accordance with the diagram below shall be permanently displayed on the outer face of the wheel in a prominent position:

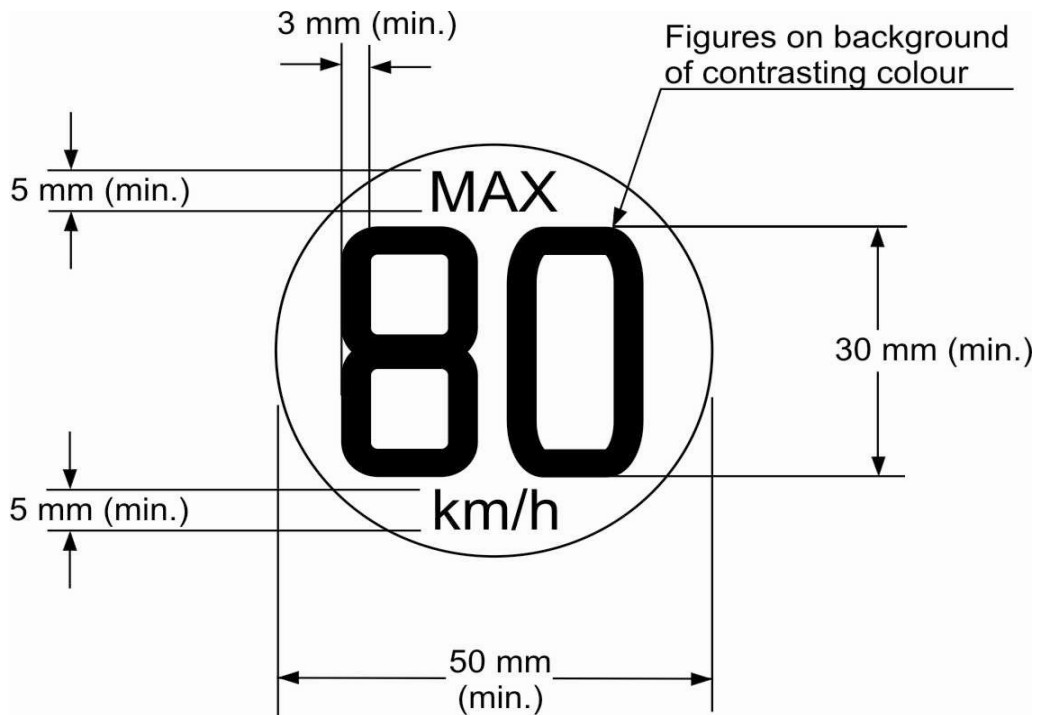

In the case of vehicles intended to be sold in countries using imperial units of measurement, an additional warning symbol, identical to that described above, with the exception that the figure "80" shall be replaced by "50" and the wording "km/h" by "mph", shall be permanently displayed on the outer face of the wheel in a prominent position.

Alternatively a single warning symbol arranged in accordance with the diagram below, shall be permanently displayed on the outer face of the wheel in a prominent position.

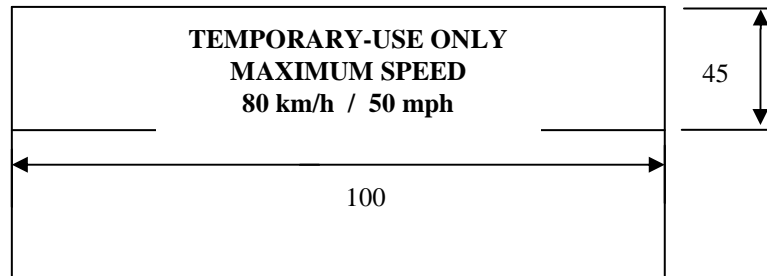

Upper case letters shall be at least 5 mm high and the numbers "80" and "50" shall be at least 20 mm high with the elements that make up each character of the number at least 3 mm line thickness. Lower case text shall at least have a line height of 5 mm. All text shall be enclosed in a border and be on a background of contrasting colour.

The requirements of this paragraph shall only apply to types 1, 2 and 3 temporary-use spare unit as defined in paragraphs 2.10.1., 2.10.2. and 2.10.3.

- 5.1.4.1.1. An 120 km/h maximum speed warning symbol arranged in accordance with the diagram below shall be permanently displayed on the outer face of the wheel in a prominent position.

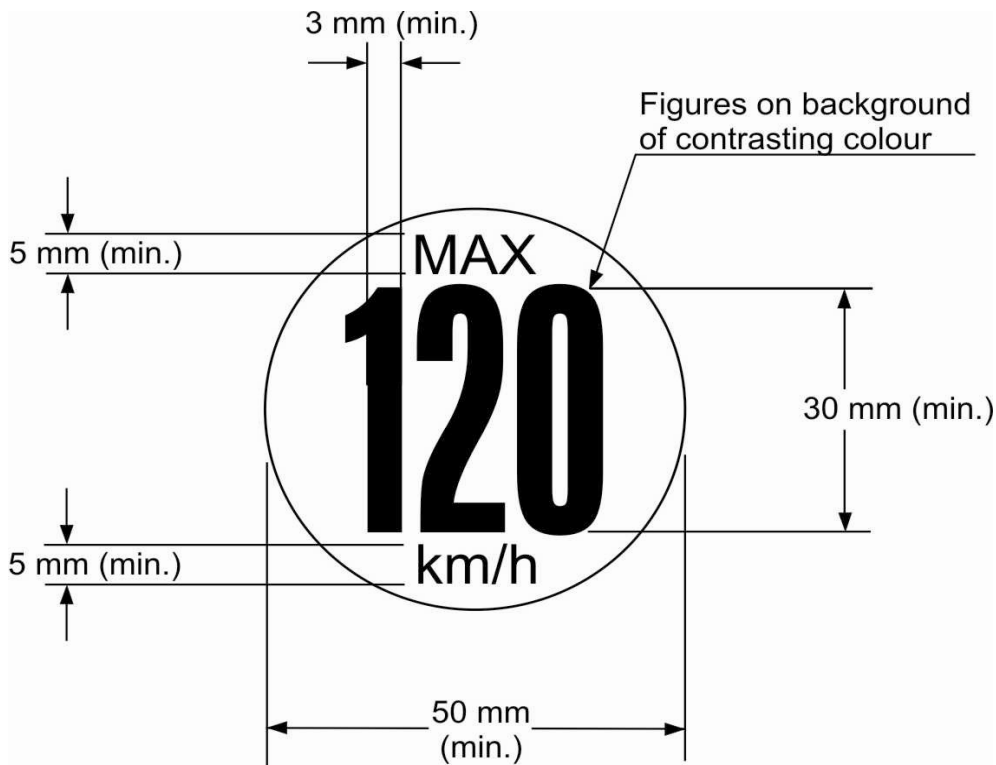

In the case of vehicles intended to be sold in countries using imperial units of measurement, an additional warning symbol, identical to that described above, with the exception that the figure "120" shall be replaced by "75" and the wording "km/h" by "mph", shall be permanently displayed on the outer face of the wheel in a prominent position.

Alternatively a single warning symbol arranged in accordance with the diagram below, shall be permanently displayed on the outer face of the wheel in a prominent position.

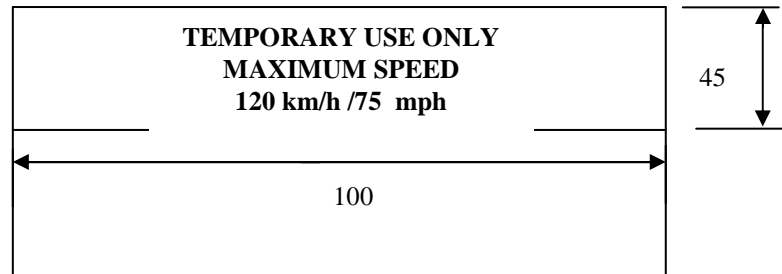

Upper case letters shall be at least 5 mm high and the numbers "120" and "75" shall be at least 20 mm high with the elements that make up each character of the number at least 3 mm line thickness. Lower case text shall at least have a line height of 5 mm. All text shall be enclosed in a border and be on a background of contrasting colour.

The requirements of this paragraph shall only apply to a type 4 temporary-use spare unit as defined in paragraph 2.10.4. to be supplied for use on an M₁ category vehicle.

- 5.1.4.2. When mounted to the vehicle for temporary-use the outward facing surface of the wheel and/or tyre shall exhibit a distinctive colour or colour pattern which is quite clearly different from the colour(s) of the standard units. If it is possible to attach a wheel cover to the temporary-use spare unit, the distinctive colour or colour pattern shall not be obscured by this wheel cover.
- 5.1.5. Except in the case of a run-flat/self supporting tyres or run-flat/extended mobility system, it is permitted to supply only one temporary-use spare unit with the vehicle.
- 5.1.6. In the case of vehicles equipped with run-flat/self supporting tyres or run-flat/extended mobility system, the vehicle shall also be fitted with a Run-Flat Warning System (defined in paragraph 2.13.) capable of operating within a speed range from 40 km/h to the maximum design speed of the vehicle and meeting the requirements of paragraphs 5.1.6.1. to 5.1.6.6. However, if the vehicle is fitted with a tyre pressure monitoring system meeting the requirements of paragraph 5.3., the additional fitment of a run-flat warning system is not required.
 - 5.1.6.1. The warning indication shall be by means of an optical yellow warning signal.
 - 5.1.6.2. The warning signal shall be activated when the ignition (start) switch is in the "on" (run) position (bulb check).
 - 5.1.6.3. A warning shall be indicated to the driver by the operation of the warning signal referred to in paragraph 5.1.6.1. at the latest when one tyre is detected to be in the flat tyre running mode.
 - 5.1.6.4. Electrical failure or sensor anomaly that affects the Run-Flat Warning System, including failure of the electrical source, supply or transmission of the output signal, shall be indicated to the driver by an optical yellow run-flat malfunction signal. If the warning signal described in paragraph 5.1.6.1. is used to indicate both a tyre in the run-flat mode and a malfunction in the run-

- flat warning system, the following shall apply: with the ignition (start) switch in the "on" (run) position the warning signal shall flash to indicate a system failure. After a short period of time the warning signal shall remain continuously illuminated as long as the failure exists and the ignition (start) switch is in the "on" (run) position. The flashing and illumination sequence shall be repeated each time the ignition (start) switch is in the "on" (run) position until the failure has been corrected.
- 5.1.6.5. When the system is being manually reset in accordance with the vehicle manufacturer's instructions the provisions in paragraphs 5.1.6.3. and 5.1.6.4. may not apply.
- 5.1.6.6. The operation of the warning signal specified in paragraphs 5.1.6.2. to 5.1.6.4. shall meet the requirements in Annex 4.
- 5.1.7. If the vehicle is equipped with a temporary-use spare unit stored in a deflated condition, a device must be provided on the vehicle which permits the tyre to be inflated to the pressure specified for temporary-use within a maximum of 10 minutes.
- 5.2. Braking test
- 5.2.1. Vehicles intended to be equipped with temporary-use spare units shall meet the requirements of Annex 3 to this Regulation.
- 5.3. Tyre Pressure Monitoring Systems (TPMS)
- 5.3.1. General Requirements
- 5.3.1.1. Subject to the requirements of paragraph 12., any vehicle of categories M₁ up to 3,500 kg and N₁, in both cases with all axles equipped with single tyres, and fitted with a tyre pressure monitoring system complying with the definition of paragraph 2.14. shall meet the performance requirements contained in paragraphs 5.3.1.2. to 5.3.5.5. below and shall be tested in accordance with Annex 5.
- 5.3.1.2. Any tyre pressure monitoring system fitted on a vehicle shall comply with the requirements of Regulation No. 10.
- 5.3.1.3. The system shall operate from a speed of 40 km/h or below, up to the vehicle's maximum design speed.
- 5.3.2. Tyre pressure detection for incident-related pressure loss (puncture test).
- 5.3.2.1. The TPMS shall be tested according to the test procedure set out in paragraph 2.6.1. of Annex 5. When tested to this procedure, the TPMS shall illuminate the warning signal described in paragraph 5.3.5 not more than 10 minutes after the in service operating pressure in one of the vehicle's tyres has been reduced by 20 per cent or it is at a minimum pressure of 150 kPa, whatever is higher.
- 5.3.3. Detection for a tyre pressure level significantly below the recommended pressure for optimum performance including fuel consumption and safety (diffusion test).
- 5.3.3.1. The TPMS shall be tested according to the test procedure set out in paragraph 2.6.2. of Annex 5. When tested to this procedure, the TPMS shall illuminate the warning signal described in paragraph 5.3.5. within not more than 60 minutes of cumulative driving time after the in-service

operating pressure in any of the vehicle's tyres, up to a total of four tyres, has been reduced by 20 per cent.

- 5.3.4. Malfunction detection test.
 - 5.3.4.1. The TPMS shall be tested according to the test procedure set out in paragraph 3. of Annex 5. When tested to this procedure, the TPMS shall illuminate the warning signal described in paragraph 5.3.5. not more than 10 minutes after the occurrence of a malfunction that affects the generation or transmission of control or response signals in the vehicle's tyre pressure monitoring system. If the system is blocked by external influence (e.g. radio-frequency noise), the malfunction detection time may be extended.
 - 5.3.5. Warning indication.
 - 5.3.5.1. The warning indication shall be by means of an optical warning signal conforming to Regulation No. 121.
 - 5.3.5.2. The warning signal shall be activated when the ignition (start) switch is in the "on" (run) position (bulb check). This requirement does not apply to tell-tales shown in a common space.
 - 5.3.5.3. The warning signal must be visible even by daylight; the satisfactory condition of the signal must be easily verifiable by the driver from the driver's seat.
 - 5.3.5.4. The malfunction indication may be the same warning signal as the one used to indicate under-inflation. If the warning signal described in paragraph 5.3.5.1. is used to indicate both under-inflation and a malfunction of the TPMS, the following shall apply: with the ignition (start) switch in the "on" (run) position the warning signal shall flash to indicate a malfunction. After a short period of time the warning signal shall remain continuously illuminated as long as the malfunction exists and the ignition (start) switch is in the "on" (run) position. The flashing and illumination sequence shall be repeated each time the ignition (start) switch is in the "on" (run) position until the malfunction has been corrected.
 - 5.3.5.5. The tell-tale of the warning described in paragraph 5.3.5.1. may be used in a flashing mode in order to provide information about the reset status of the tyre pressure monitoring system in accordance with the owner's manual of the vehicle.

6. Supplementary information

- 6.1. If the vehicle is equipped with a temporary-use spare unit, the owner's manual of the vehicle shall contain at least the following information:
 - 6.1.1. A statement of the risk resulting from non-compliance with the restrictions on the use of a temporary-use spare unit including, as appropriate, a statement relating to use restricted to a specific axle;
 - 6.1.2. An instruction to drive with caution and at no more than the permitted maximum speed of 80 km/h (50 mph) when a type 1, 2 or 3 temporary-use spare unit as defined in paragraphs 2.10.1., 2.10.2. or 2.10.3. is fitted, and to reinstall a standard unit as soon as possible. It shall be made clear that this instruction also applies to a type 5 temporary-use spare unit as defined in paragraph 2.10.5. being used in the flat tyre running mode;

- 6.1.2.1. An instruction to drive with caution and at no more than the permitted maximum speed of 120 km/h (75 mph), when a type 4 spare unit as defined in paragraph 2.10.4. is fitted, and to reinstall a standard unit as soon as possible.
- 6.1.3. A statement that operation of the vehicle is not permitted with more than one temporary-use spare unit fitted at the same time. This requirement shall only apply to a type 1, 2 and 3 temporary-use spare unit as defined in paragraphs 2.10.1., 2.10.2. and 2.10.3;
- 6.1.4. A clear indication of the inflation pressure specified by the vehicle manufacturer for the tyre of the temporary-use spare unit;
- 6.1.5. For vehicles equipped with a temporary-use spare unit stored in a deflated condition, a description of the procedure for inflating the tyre to the pressure specified for temporary-use by means of the device referred to in paragraph 5.1.7. above.
- 6.2. If the vehicle is fitted with a Tyre Pressure Monitoring System or a Run-flat Warning System, the owner's manual of the vehicle shall contain at least the following information:
 - 6.2.1. A statement that the vehicle is equipped with such a system (and information how to reset the system, if the actual system includes such a feature).
 - 6.2.2. An image of the tell-tale symbol described in paragraph 5.1.6.1. or 5.3.5.1. as appropriate (and an image of the malfunction tell-tale symbol, if a dedicated tell-tale is used for this function).
 - 6.2.3. Additional information about the significance of the low tyre pressure warning tell-tale illuminating and a description of the corrective action to be undertaken if this happens.
- 6.3. If no owner's manual is supplied with the vehicle, the information required in paragraph 6.1. and/or 6.2. above shall be displayed in a prominent place on the vehicle.

7. Modifications and extension of approval of the vehicle type

- 7.1. Every modification of the vehicle type shall be notified to the Administrative Department which granted the type approval. The department may then either:
 - 7.1.1. Consider that the modifications made are unlikely to have appreciable adverse effects and that in any event the vehicle still complies with the requirements; or
 - 7.1.2. Require a further test report from the Technical Service responsible for conducting the tests.
- 7.2. Confirmation or refusal of approval, specifying the alterations, shall be notified by the procedure specified in paragraph 4.3. above to the Parties to the Agreement applying this Regulation.
- 7.3. The Administrative Department issuing the extension of approval shall assign a series number to each communication form drawn up for such an extension.

8. Conformity of production

- 8.1. The Conformity of Production procedures shall comply with those set out in Appendix 2 of the Agreement (E/ECE/324–E/ECE/TRANS/505/Rev.2), with the following requirements:
- 8.2. The Administrative Department which has granted type approval, may at any time verify the conformity of production in each production facility. The normal frequency of these verifications shall be at least once per year.

9. Penalties for non-conformity of production

- 9.1. The approval granted in respect of a vehicle type pursuant to this Regulation may be withdrawn if the requirements laid down in paragraph 8 are not complied with.
- 9.2. If a Party to the Agreement which applies this Regulation withdraws an approval it has previously granted, it shall forthwith so notify the other Contracting Parties applying this Regulation, by means of a copy of the approval form bearing at the end, in large letters, the signed and dated annotation "APPROVAL WITHDRAWN".

10. Production definitely discontinued

If the holder of the approval completely ceases to manufacture a type of vehicle approved in accordance with this Regulation, he shall so inform the authority which granted the approval. Upon receiving the relevant communication that authority shall inform thereof the other Parties to the Agreement applying this Regulation by means of a copy of the approval form bearing at the end, in large letters, the signed and dated annotation "PRODUCTION DISCONTINUED".

11. Names and addresses of Technical Services responsible for conducting approval tests, and of Administrative Departments

The Parties to the Agreement which apply this Regulation shall communicate to the United Nations Secretariat the names and addresses of the Technical Services responsible for conducting approval tests and of the Administrative Departments which grant approval and to which forms certifying approval or extension or refusal or withdrawal of approval, issued in other countries, are to be sent.

12. Transitional provisions

- 12.1. As from the official date of entry into force of the 01 series of amendments, no Contracting Party applying this Regulation shall refuse to grant approval under this Regulation as amended by the 01 series of amendments.
- 12.2. As from 36 months after the date of entry into force of the 01 series of amendments, Contracting Parties applying this Regulation with respect to the

- temporary-use spare wheels/tyres, run-flat tyres or a run-flat system shall grant approvals only if the vehicle type to be approved meets the requirements of this Regulation as amended by the 01 series of amendments.
- 12.3. Contracting Parties applying this Regulation shall not refuse to grant extensions of approval to the preceding series of amendments to this Regulation.
- 12.4. Contracting Parties applying this Regulation shall continue to grant approvals to those types of vehicles which comply with the requirements of this Regulation as amended by the preceding series during the 36 months' period which follows the date of entry into force of the 01 series of amendments.
- 12.5. As from the official date of entry into force of the 02 series of amendments to this Regulation, no Contracting Party applying this Regulation shall refuse to grant approval under this Regulation as amended by the 02 series of amendments.
- 12.6. As from 1 November 2012, Contracting Parties applying this Regulation may refuse to grant national or regional approval to a vehicle type of categories M₁ up to a maximum mass of 3,500 kg and N₁, in both cases with all axles equipped with single tyres, if the vehicle type does not meet the requirements of the 02 series of amendments to this Regulation.
- 12.7. As from 1 November 2014, Contracting Parties applying this Regulation may refuse first national or regional registration (first entry into service) of a vehicle in categories M₁ up to a maximum mass of 3,500 kg and N₁, in both cases with all axles equipped with single tyres, if the vehicle type does not meet the requirements of the 02 series of amendments to this Regulation.
- 12.8. Notwithstanding the transitional provisions above, Contracting Parties whose application of this Regulation comes into force after the date of entry into force of the most recent series of amendments are not obliged to accept approvals which were granted in accordance with any of the preceding series of amendments to this Regulation.

Annex 1

Communication

(maximum format: A4 (210 x 297 mm))

issued by: Name of administration:

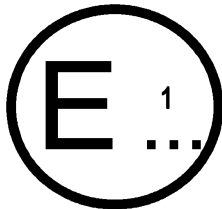

.....
.....
.....

concerning:²

APPROVAL
APPROVAL EXTENDED
APPROVAL REFUSED
APPROVAL WITHDRAWN
PRODUCTION DEFINITELY DISCONTINUED

of a vehicle type with regard to their equipment which may include: a temporary-use spare unit, run-flat tyres and/or a run-flat system², and/or a tyre pressure monitoring system pursuant to Regulation No. 64.

Approval No.:

Extension No.:

1. Trade name or mark of the vehicle:
.....
2. Vehicle type (if applicable, variants that are included):
3. Manufacturer's name and address:
4. If applicable, name and address of the manufacturer's representative:
.....
5. Vehicle submitted for approval on:
6. Technical Service responsible for conducting approval tests:
7. Date of test report:
8. Number of test report:
9. Brief description of the vehicle type:

¹ Distinguishing number of the country which has granted/extended/refused/withdrawn approval (see approval provisions in the Regulation).

² Strike out what does not apply.

- 9.1. Mass of the vehicle when tested:
Front axle:
Rear axle:
Total:
- 9.2. Marking and wheel size(s) of standard unit equipment:
- 9.3. Details of temporary-use spare unit, including wheel and tyre size designations and marking, tyre load and speed capability, run-flat tyre including the maximum distance wheel offset (where different from standard unit).
- 9.4. The vehicle is fitted with a run-flat warning system yes/no²
If the answer to the above item is yes, the run-flat warning system meets the requirements of paragraphs 5.1.6. to 5.1.6.6./meets the requirements of paragraphs 5.3. to 5.3.5.5. (tyre pressure monitoring system)²
- 9.5. The vehicle is fitted with a tyre pressure monitoring system meeting the requirements of paragraphs 5.3. to 5.3.5.5 yes/no²
- 9.6. Brief description of run-flat warning system/tyre pressure monitoring system where applicable
10. Result of the tests:

	Measured Time to warning (mm:ss)
"Puncture test"	
"Diffusion test"	
"Malfunction test"	

11. Position of approval mark:
12. Reason(s) of extension (if applicable):
13. Approval granted/refused/extended/withdrawn²
14. Place:
15. Date:
16. Signature:
17. The list of documents deposited with the Administrative Department which has grantedapproval is annexed to this communication and can be obtained upon request.

Annex 2

Arrangements of approval marks

Model A

(See paragraph 4.4. of this Regulation)

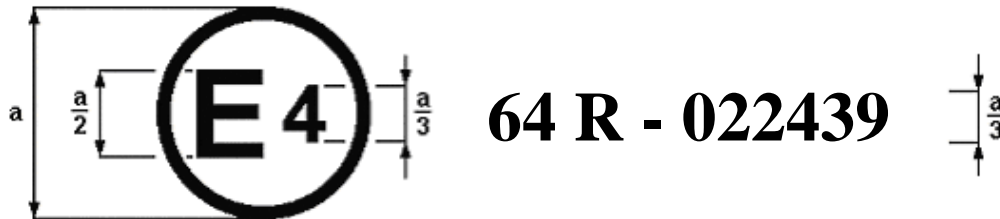

$a = 8 \text{ mm min.}$

The above approval mark affixed to a vehicle shows that the vehicle type concerned has, with regard to the equipment of temporary-use spare unit(s), been approved in the Netherlands (E 4), pursuant to Regulation No. 64 under approval number 022439. The approval number indicates that the approval was granted in accordance with the requirements of Regulation No. 64, incorporating the 02 series of amendments.

Model B

(See paragraph 4.5. of this Regulation)

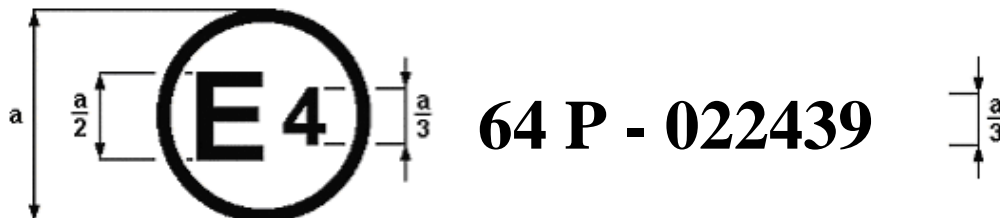

$a = 8 \text{ mm min.}$

The above approval mark affixed to a vehicle shows that the vehicle type concerned has, with regard to the equipment of a tyre pressure monitoring system, been approved in the Netherlands (E 4), pursuant to Regulation No. 64 under approval number 022439. The approval number indicates that the approval was granted in accordance with the requirements of Regulation No. 64, incorporating the 02 series of amendments.

Model C

(See paragraph 4.5. of this Regulation)

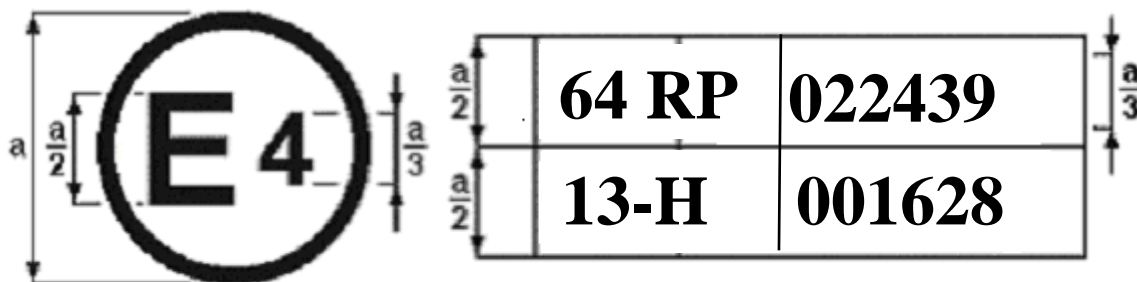

a = 8 mm min.

The above approval mark affixed to a vehicle shows that the vehicle type concerned has been approved in the Netherlands (E 4) pursuant to Regulation Nos. 64 (with respect to the equipment of temporary-use spare unit(s) and equipment with a tyre pressure monitoring system) and 13-H¹. The approval numbers indicate that, at the dates when the respective approvals were given, Regulation No. 64 included the 02 series of amendments and Regulation No. 13-H was in its original form.

¹ The latter number is given as an example only.

Annex 3

Braking and deviation test for vehicles fitted with temporary-use spare units

1. General conditions
 - 1.1. The test track shall be substantially level and have a surface affording good adhesion.
 - 1.2. The test shall be performed when there is no wind liable to affect the results.
 - 1.3. The vehicle shall be loaded to its maximum mass as defined in paragraph 2.9. of this Regulation.
 - 1.4. The axle loads resulting from the loading condition in accordance with paragraph 1.3. of this annex shall be proportional to the maximum axle loads as defined in paragraph 2.10 of this Regulation.
 - 1.5. Except in the case of a run-flat tyre, the tyres shall be inflated to the pressures recommended by the vehicle manufacturer for the vehicle type and loading condition. A run-flat tyre shall be tested in the fully deflated condition.
2. Braking and deviation test
 - 2.1. The test shall be carried out with the temporary-use spare unit fitted alternately in place of one front wheel and one rear wheel. However, if use of the temporary-use spare unit is restricted to a specific axle, the test shall be carried out only with the temporary-use spare unit fitted to that axle.
 - 2.2. The test shall be carried out using the service braking system from an initial speed of 80 km/h with the engine disconnected.
 - 2.3. The braking performance shall correspond to the test procedure given in Regulation No. 13 or 13-H for categories M₁ and N₁ vehicles for the Type O cold test with the engine disconnected:
 - 2.3.1. In the case of M₁ category vehicles approved to Regulation No. 13 fitted with types 1, 2, 3 and 5 temporary-use spare units as defined in paragraphs 2.10.1., 2.10.2., 2.10.3. and 2.10.5. and tested using a prescribed speed of 80 km/h;

The stopping distance achieved using a maximum force of 500 N applied to the foot control shall not exceed 50.7 m and;

The mean fully developed deceleration (mfdd) given by the following formula shall be not less than 5.8 ms⁻²:
$$\text{Mfdd} = v^2/41.14 \text{ s}$$
where "v" is the initial speed at which braking commences and "s" is the distance covered during braking between 0.8 v and 0.1 v.
 - 2.3.1.1. In the case of N₁ category vehicles approved to Regulation No. 13 fitted with types 1, 2, 3 and 5 temporary-use spare units as defined in paragraphs 2.10.1., 2.10.2., 2.10.3. and 2.10.5. and tested using a prescribed speed of 80 km/h;

The stopping distance achieved using a maximum force of 700 N applied to the foot control shall not exceed 61.2 m and;

The mean fully developed deceleration (mfdd) given by the following formula shall be not less than 5.0 ms^{-2} :

$$\text{Mfdd} = v^2/41.14 \text{ s}$$

where v is the initial speed at which braking commences and s is the distance covered during braking between $0.8 v$ and $0.1 v$.

- 2.3.1.2. In the case of M_1 category vehicles approved to Regulation No. 13 fitted with type 4 spare unit as defined in paragraph 2.10.4. tested using a prescribed speed of 120 km/h;

The stopping distance achieved using a maximum force of 500 N applied to the foot control, shall not exceed 108 m and;

The mean fully developed deceleration (mfdd) given by the following formula shall be not less than 5.8 ms^{-2} :

$$\text{Mfdd} = v^2/41.14 \text{ s}$$

where " v " is the initial speed at which braking commences and " s " is the distance covered during braking between $0.8 v$ and $0.1 v$.

- 2.3.1.3. In the case of M_1 or N_1 category vehicles approved to Regulation No. 13-H fitted with types 1, 2, 3 and 5 temporary-use spare units as defined in paragraphs 2.10.1., 2.10.2., 2.10.3. and 2.10.5. and tested using a prescribed speed of 80 km/h;

The stopping distance achieved using a maximum force of $650 \text{ N} + 0 / -50 \text{ N}$ applied to the foot control, shall not exceed 46.4 m and;

The mean fully developed deceleration (mfdd) given by the following formula shall be not less than 6.43 ms^{-2} :

$$\text{Mfdd} = v^2/41.14 \text{ s}$$

where " v " is the initial speed at which braking commences and " s " is the distance covered during braking between $0.8 v$ and $0.1 v$.

- 2.3.1.4. In the case of M_1 category vehicles approved to Regulation No. 13-H fitted with type 4 temporary-use spare unit as defined in paragraph 2.10.4. and tested using a prescribed speed of 120 km/h;

The stopping distance achieved using a maximum force of $650 \text{ N} + 0 / -50 \text{ N}$ applied to the foot control, shall not exceed 98.4 m and;

The mean fully developed deceleration (mfdd) given by the following formula shall be not less than 6.43 ms^{-2} :

$$\text{Mfdd} = v^2/41.14 \text{ s}$$

where " v " is the initial speed at which braking commences and " s " is the distance covered during braking between $0.8 v$ and $0.1 v$.

- 2.4. Tests shall be carried out for each of the fitting conditions of temporary-use spare units specified in paragraph 2.1. of this annex.

- 2.5. The prescribed braking performance shall be obtained without any wheel-locking, deviation of the vehicle from its intended course, abnormal vibration, abnormal wear of the tyre during the test or excessive steering correction.

Annex 4

Test requirements for Run-Flat Warning System (RFWS)

1. Test conditions
 - 1.1. Ambient temperature
The ambient temperature shall be between 0 °C and 40 °C.
 - 1.2. Test road surface
The test road surface shall be dry and smooth.
 - 1.3. Test location
The test location shall be other than an environment susceptible to radio wave interference such as a strong electric field.
 - 1.4. Condition of the test vehicle in a stationary state
The vehicle's tyres shall be shaded from direct sun when the vehicle is parked.
2. Test method
 - 2.1. Test procedures for detection of a tyre in the flat tyre running mode.
The requirements of either paragraph 2.1.1. or 2.1.2. shall be met.
 - 2.1.1. Test 1
 - 2.1.1.1. The tyres are to be inflated to the pressure recommended by the vehicle manufacturer.
 - 2.1.1.2. With the vehicle stationary and the ignition (start) switch in the "Lock" or "Off" position, turn the ignition (start) switch to the "On" ("Run") position or, where applicable, the appropriate key position. Confirm the activation of the warning signal.
 - 2.1.1.3. Turn off the ignition and reduce the inflation pressure of any one of the tyres until the adjusted tyre inflation pressure is 100 kPa below the recommended cold inflation pressure.
 - 2.1.1.4. Within 5 minutes after reducing the inflation pressure of the tyre, drive the vehicle normally between 40 and 100 km/h.
 - 2.1.1.5. The test is completed when either:
 - (a) The run-flat warning system as described in paragraph 5.1.6.1. has activated; or
 - (b) A period of 5 minutes has elapsed, when determined in accordance with paragraph 2.3., from the time the test speed has been reached. If the warning does not activate the test has failed.

The vehicle shall be brought to a halt and the ignition switched off.
 - 2.1.1.6. If the warning signal as required in paragraph 2.1.1.5. above has activated, wait 5 minutes before turning the ignition on; the signal must reactivate and remain active as long as the ignition switch is in the "on" ("run") position.

- 2.1.1.7. Repeat the process described in paragraphs 2.1.1.1. to 2.1.1.6., but with a test speed of 130 km/h or higher. All the relevant requirements shall be met for both test speeds.
- 2.1.2. Test 2
- 2.1.2.1. The tyres are to be inflated to the pressure recommended by the vehicle manufacturer.
- 2.1.2.2. With the vehicle stationary and the ignition (start) switch in the "Lock" or "Off" position, turn the ignition (start) switch to the "On" ("Run") position or, where applicable, the appropriate key position. Confirm the activation of the warning signal. Turn off the ignition.
- 2.1.2.3. Produce on one tyre a gradual pressure loss of between 10 kPa/min and 20 kPa/min.
- 2.1.2.4. Drive the vehicle at any speed above 25 km/h.
- 2.1.2.5. The test requirement is satisfied if the system delivers an alert by the time the pressure drop has reached 100 kPa.
- 2.2. Test procedures for detecting a failure of the Run-Flat Warning System.
- 2.2.1. With the vehicle in the normal use condition, simulate a Run-Flat Warning System failure. This may be simulated by, for example, disconnecting connectors for wiring related to the power supply from the power source or wiring related to the input/output to/from the warning system control.
- 2.2.2. With a simulated fault introduced, drive the vehicle normally between 40 and 100 km/h.
- 2.2.3. When:
- (a) The run-flat malfunction signal as described in paragraph 5.1.6.4. has activated or;
 - (b) A period of 5 minutes has elapsed, when determined in accordance with paragraph 2.3., from the time the test speed has been reached. If the warning does not activate the test has failed.
- The vehicle shall be brought to a halt and the ignition switched off.
- 2.2.4. If the warning signal as required in paragraph 2.2.3. above has activated, wait 5 minutes before turning the ignition on; the signal must reactivate and remain active as long as the ignition switch is in the "on" ("run") position.
- 2.3. Calculation of time duration
- The time to be taken for determination of the requirements of paragraphs 2.1.1.5. and 2.2.3. shall be the total elapsed time while the vehicle is driven in the test speed range 40 km/h to 100 km/h.
- The time shall be calculated over a continuous drive but it is not necessary that the vehicle maintains throughout the test a speed within the test speed range. Where the vehicle speed falls outside the test speed range, any time accumulated during such events shall not be considered as part of the total test time duration.
- The type Approval Authority shall satisfy itself that the run-flat warning system records the time within the test speed range on a cumulative basis and does not restart the time calculation if the vehicle falls outside the test speed range.

Annex 5

Tests for Tyre Pressure Monitoring Systems (TPMS)

1. Test conditions
 - 1.1. Ambient temperature.

The ambient temperature shall be between 0 °C and 40 °C.
 - 1.2. Road test surface.

The road shall have a surface affording good adhesion. The road surface shall be dry during testing.
 - 1.3. The tests shall be conducted in an environment free of interferences from radio wave.
 - 1.4. Vehicle conditions.
 - 1.4.1. Test weight.

The vehicle may be tested at any condition of load, the distribution of the mass among the axles being that stated by the vehicle manufacturer without exceeding any of the maximum permissible mass for each axle.

However, in the case where there is no possibility to set or reset the system, the vehicle shall be unladen. There may be, in addition to the driver, a second person on the front seat who is responsible for noting the results of the tests. The load condition shall not be modified during the test.
 - 1.4.2. Vehicle speed.

The TPMS shall be calibrated and tested:

 - (a) In a speed range from 40 km/h and 120 km/h or the vehicle's maximum design speed if it is less than 120 km/h for the puncture test to verify the requirements of paragraph 5.3.2. to this Regulation; and
 - (b) In a speed range from 40 km/h and 100 km for the diffusion test to verify the requirements of paragraph 5.3.3 to this Regulation and for the malfunction test to verify the requirements of paragraph 5.3.4. to this Regulation.

The whole speed range shall be covered during the test.

For vehicles equipped with cruise control, the cruise control shall not be engaged during testing.
 - 1.4.3. Rim position.

The vehicle rims may be positioned at any wheel position, consistent with any related instructions or limitations from the vehicle's manufacturer.
 - 1.4.4. Stationary location.

When the vehicle is parked, the vehicle's tyres shall be shaded from direct sun. The location shall be shielded from any wind that may affect the results.

- 1.4.5. Brake pedal application.
Driving time shall not accumulate during service brake application while the vehicle is moving.
- 1.4.6. Tyres.
The vehicle shall be tested with the tyres installed on the vehicle according to the vehicle manufacturer's recommendation. However, the spare tyre may be utilised for testing TPMS malfunction.
- 1.5. Accuracy of pressure measurement equipment.
Pressure measurement equipment to be used for the tests contained in this annex shall be accurate to at least ± 3 kPa.
2. Test procedure
The test shall be performed at a test speed within the range in accordance with paragraph 1.4.2. to this annex, at least once for the test case according to paragraph 2.6.1. to this annex ("puncture test"), and at least once for each test case according to paragraph 2.6.2. to this annex ("diffusion test").
- 2.1. Before inflating the vehicle's tyres, leave the vehicle stationary outside at ambient temperature with the engine off shaded from direct sunlight and not exposed to wind or other heating or chilling influences for at least one hour. Inflate the vehicle's tyres to the vehicle manufacturer's recommended cold inflation pressure (P_{rec}), in accordance with the vehicle manufacturer's recommendation for the speed and load conditions, and tyre positions. All pressure measurements shall be carried out using the same test equipment.
- 2.2. With the vehicle stationary and the ignition locking system in the "Lock" or "Off" position, activate the ignition locking system to the "On" or "Run" position. The tyre pressure monitoring system shall perform a check of lamp function for the low tyre pressure tell-tale as specified in paragraph 5.3.5.2. of this Regulation. This last requirement does not apply to tell-tales shown in a common space.
- 2.3. If applicable, set or reset the tyre pressure monitoring system in accordance with the vehicle manufacturer's recommendations.
- 2.4. Learning phase.
- 2.4.1. Drive the vehicle for a minimum of 20 minutes within the speed range in paragraph 1.4.2. to this Annex, and with an average speed of 80 km/h (± 10 km/h). It is allowed to be outside the speed range for a maximum cumulative time of 2 minutes during the learning phase.
- 2.4.2. At the discretion of the Technical Service, where the driving test is undertaken on a track (circle/oval) with only turns in a single direction, then the driving test in paragraph 2.4.1 above should be equally split (± 2 minutes) in both directions
- 2.4.3. Within the 5 minutes of completing the learning phase, measure the warm pressure of the tyre(s) to be deflated. The warm pressure shall be taken as the value P_{warm} . This value will be used for subsequent operations.

- 2.5. Deflation phase.
- 2.5.1. Procedure for the puncture test to verify the requirements of paragraph 5.3.2. to this Regulation.
- Deflate one of the vehicle's tyres within 5 minutes of measuring the warm pressure as described in paragraph 2.4.3. above, until it is at P_{warm} -20 per cent, or it is at a minimum pressure of 150 kPa, whichever is higher, namely P_{test} . Following a stabilisation period of between 2 and 5 minutes the pressure P_{test} shall be rechecked and adjusted if necessary.
- 2.5.2. Procedure for the diffusion test to verify the requirements of paragraph 5.3.3. to this Regulation.
- Deflate all four tyres within 5 minutes of measuring the warm pressure as described in paragraph 2.4.3. above, until the deflated tyres are at P_{warm} - 20 per cent plus a further deflation of 7 kPa, namely P_{test} . Following a stabilisation period of between 2 and 5 minutes the pressure P_{test} shall be rechecked and adjusted if necessary.
- 2.6. Low tyre pressure detection phase.
- 2.6.1. Procedure for the puncture test to verify the requirements of paragraph 5.3.2. to this Regulation.
- 2.6.1.1. Drive the vehicle along any portion of the test course (not necessarily continuously). The sum of the total cumulative drive time shall be the lesser of 10 minutes or the time at which the low tyre pressure tell-tale illuminates.
- 2.6.2. Procedure for the diffusion test to verify the requirements of paragraph 5.3.3. to this Regulation.
- 2.6.2.1. Drive the vehicle along any portion of the test course. After not less than 20 minutes and not more than 40 minutes bring the vehicle to a complete standstill with the engine switched off and the ignition key removed for not less than 1 minute or more than 3 minutes. Resume the test. The sum of the total cumulative drive time shall be the lesser of 60 minutes of cumulative driving under the conditions set out in paragraph 1.4.2. above or the time at which the low tyre pressure tell-tale illuminates.
- 2.6.3. If the low tyre pressure signal did not illuminate, discontinue the test.
- 2.7. If the low tyre pressure tell-tale illuminated during the procedure in paragraph 2.6. above, deactivate the ignition locking system to the "Off" or "Lock" position. After a 5 minutes period, reactivate the vehicle's ignition locking system to the "On" ("Run") position. The tell-tale must illuminate and remain illuminated as long as the ignition locking system is in the "On" ("Run") position.
- 2.8. Inflate all of the vehicle's tyres to the vehicle manufacturer's recommended cold inflation pressure. Reset the system in accordance with the instructions of the vehicle manufacturer. Determine whether the tell-tale has extinguished. If necessary, drive the vehicle until the tell-tale has been extinguished. If the tell-tale does not extinguish, discontinue the test.

- 2.9. Repetition of the deflation phase.
- The test may be repeated, at the same or different loads, using the relevant test procedures in paragraphs 2.1. to 2.8. above, with the relevant tyre(s) on the vehicle under-inflated, in accordance with the provisions of paragraph 5.3.2. or 5.3.3. to this Regulation, whichever is relevant.
3. TPMS malfunction detection
- 3.1. Simulate a TPMS malfunction, for example, by disconnecting the power source to any TPMS component, disconnecting any electrical connection between TPMS components, or installing a tyre or wheel on the vehicle that is incompatible with the TPMS. When simulating a TPMS malfunction, the electrical connections for the tell-tale lamps shall not be disconnected.
- 3.2. Drive the vehicle for up to 10 minutes of cumulative time (not necessarily continuously) along any portion of the test course.
- 3.3. The sum of the total cumulative drive time under paragraph 3.2. shall be the lesser of 10 minutes or the time at which the TPMS malfunction tell-tale illuminates.
- 3.4. If the TPMS malfunction indicator did not illuminate in accordance with paragraph 5.3.4 to this Regulation, as required, discontinue the test.
- 3.5. If the TPMS malfunction indicator is illuminated or illuminates during the procedure in paragraphs 3.1 to 3.3 above, deactivate the ignition locking system to the "Off" or "Lock" position. After 5 minutes, reactivate the vehicle's ignition locking system to the "On" ("Run") position. The TPMS malfunction indicator shall again signal a malfunction and remain illuminated as long as the ignition locking system is in the "On" ("Run") position.
- 3.6. Restore the TPMS to normal operation. If necessary, drive the vehicle until the warning signal has extinguished. If the warning lamp has not extinguished, discontinue the test.
- 3.7. The test may be repeated using the test procedures in paragraphs 3.1. to 3.6. above, with each such test limited to simulation of a single malfunction.
-