

16 July 1999

AGREEMENT

CONCERNING THE ADOPTION OF UNIFORM TECHNICAL PRESCRIPTIONS
FOR WHEELED VEHICLES, EQUIPMENT AND PARTS WHICH CAN BE FITTED
AND/OR
BE USED ON WHEELED VEHICLES AND THE CONDITIONS FOR RECIPROCAL
RECOGNITION
OF APPROVALS GRANTED ON THE BASIS OF THESE PRESCRIPTIONS */

(Revision 2, including the amendments entered into force on 16 October 1995)

Addendum 62 : Regulation No. 63

Amendment 1

01 series of amendments - Date of entry into force: 8 March 1999

UNIFORM PROVISIONS CONCERNING THE APPROVAL OF TWO-WHEELED MOPEDS WITH REGARD TO NOISE



UNITED NATIONS

*/ Former title of the Agreement:

Agreement Concerning the Adoption of Uniform Conditions of Approval and Reciprocal Recognition of Approvals Granted on the Basis of Technical Prescriptions for Wheeled Vehicles, Equipment and Parts, done at Geneva on 20 March 1958.

GE.99-

Title, amend to read:

"UNIFORM PROVISIONS CONCERNING THE APPROVAL OF TWO-WHEELED MOPEDS
WITH REGARD TO NOISE"

Contents,

Add the following new paragraph 10:

"10. Transitional provisions"

Paragraphs 10 and 11 (former), renumber as paragraphs 11 and 12.

Add the title of a new Annex 5, to read:

"Annex 5: Test track specifications"

Text of the Regulation

General amendment Throughout the text of the Regulation, replace the words "silencing system(s) ..." by "exhaust or silencing system(s) ...".

Paragraph 2.1., amend to read:

"2.1. 'Approval of a moped' means the approval of a moped type with regard to noise and the original exhaust system as a technical component of a two-wheeled type of moped."

Paragraph 2.2.1., amend to read:

"2.2.1. The type of engine (two-stroke or four-stroke; with reciprocating or rotary pistons; number and capacity of cylinders; number and type of carburettors or injection systems; arrangement of valves; maximum net power and corresponding engine speed).

For rotary piston engines, the cubic capacity should be taken to be double of the volume of the chamber;"

Paragraph 2.2.3., amend to read:

"2.2.3. The number, type and arrangement of exhaust systems."

Insert new paragraphs 2.2.3.1. to 2.2.3.3., to read:

"2.2.3.1. 'Exhaust or silencing system' means a complete set of components necessary for limiting the noise made by the engine of the moped and its exhaust;

2.2.3.2. 'Original exhaust or silencing system' means a system of the type fitted to the vehicle on approval or extension of approval. It may be original or a replacement.

2.2.3.3. 'Non-original exhaust or silencing system' means a system of a type different from that fitted to the vehicle on approval or extension of approval. It may be used only as a replacement exhaust or silencing system."

Paragraph 2.5., amend to read (deleting also footnote 2/):

"2.5. 'Exhaust system component' means one of the individual constituent parts which, when assembled, constitute the exhaust system (e.g, exhaust pipes, silencer) and, where applicable, the intake device (air filter).

If the engine is fitted with an intake device (air filter and/or an intake noise absorber essential in order to ensure conformity with noise-level limits), this device shall be considered to be a component of the same importance as the exhaust system proper, and be included in the list referred to in paragraph 3.2.2. and carry the markings prescribed in paragraph 4.1."

Insert a new paragraph 4.1.3., to read:

"4.1.3. All packagings of original replacements for exhaust silencing systems shall be marked "original part" and bear clearly legible make and type references."

Paragraph 5.2., amend to read:

"5.2. An approval number shall be assigned to each type approved. Its first two digits (at present 01 for the 01 series of amendments entering into force on ...) shall indicate the series ..."

Paragraph 5.4.1., the reference to footnote 1/ and footnote 1/ itself become a reference to footnote 2/ and footnote 2/. Amend footnote 2/ to read:

"2/ 1 for Germany, ... 8 for the Czech Republic, ... 15 (vacant), ... 22 for the Russian Federation, 23 for Greece, 24 for Ireland, 25 for Croatia, 26 for Slovenia, 27 for Slovakia, 28 for Belarus, 29 for Estonia, 30 (vacant), 31 for Bosnia and Herzegovina, 32 for Latvia, 33-36 (vacant), 37 for Turkey, 38-39 (vacant), 40 for The former Yugoslav Republic of Macedonia, 41 (vacant), 42 for the European Community (Approvals are granted by its Member States using their respective ECE symbol) and 43 for Japan. Subsequent numbers to the Agreement Concerning the Adoption of Uniform Technical Prescriptions for Wheeled Vehicles, Equipment and Parts which can be Fitted and/or be Used on Wheeled Vehicles and the Conditions for Reciprocal Recognition of Approvals Granted on the Basis of these Prescriptions,

Paragraph 6.2.1.1., the reference to footnote 1/ and footnote 1/ itself become a reference to footnote 3/ and footnote 3/.

Paragraph 7., amend to read:

"7. MODIFICATIONS AND EXTENSION OF THE APPROVAL OF THE MOPED TYPE OR OF THE TYPE OF EXHAUST OR SILENCING SYSTEM(S)"

Add a new paragraph 7.3., to read:

"7.3. The competent authority which issued the approval extension shall assign a serial number to the extension and shall so notify the other Parties to the 1958 Agreement applying this Regulation, by

means of a communication form conforming to the model in annex 1 to this Regulation."

Paragraph 8., amend to read:

"8. CONFORMITY OF PRODUCTION

The conformity of production procedures shall comply with those set out in the Agreement, Appendix 2 (E/ECE/324-E/ECE/TRANS/505/Rev.2), with the following requirements:"

Paragraph 9.2., amend to read:

"... the other Parties to the 1958 Agreement applying this Regulation, by means of a communication form conforming to the model in annex 1 of this Regulation."

Add a new paragraph 10., to read:

"10. TRANSITIONAL PROVISIONS

- 10.1. As from the official date of entry into force of the 01 series of amendments, no Contracting Party applying this Regulation shall refuse to grant ECE approval under this Regulation as amended by the 01 series of amendments.
- 10.2. As from 17 June 1999, Contracting Parties applying this Regulation shall grant ECE approvals only if the moped-type to be approved meets the requirements of this Regulation as amended by the 01 series of amendments.
- 10.3. Contracting Parties applying this Regulation shall not refuse to grant extensions of approval in accordance with the preceding series of amendments to this Regulation.
- 10.4. Contracting Parties applying this Regulation shall continue to grant approvals to those types of mopeds which conform to the requirements of this Regulation as amended by the preceding series of amendments until 17 June 1999 only.
- 10.5. ECE approvals granted under this Regulation before 17 June 1999 and all extensions of such approvals, including those granted subsequently under a preceding series of amendments to this Regulation, shall remain valid indefinitely. When the moped type approved under the preceding series of amendments meets the requirements of this Regulation as amended by the 01 series of amendments, the Contracting Party which granted the approval shall so notify the other Contracting Parties applying this Regulation.
- 10.6. No Contracting Party applying this Regulation shall refuse national type approval of a moped type approved under the 01 series of amendments to this Regulation or meeting the requirements thereof.
- 10.7. Until 17 June 2003 no Contracting Party applying this Regulation shall refuse national type approval for a moped type approved in accordance with the 01 series of amendments to this Regulation.

10.8. As from 17 June 1999 Contracting Parties applying this Regulation may refuse first national registration (first entry into service) of a moped which does not meet the requirements of the 01 series of amendments to this Regulation."

Paragraph 10 (former), renumber as paragraph 11 and amend to read:

"11. PRODUCTION DEFINITELY DISCONTINUED

If the holder of the approval completely ceases production of a type of moped approved in accordance with this Regulation, he shall so inform the authority which granted the approval, which in turn shall notify the other Parties to the 1958 Agreement applying this Regulation, by means of a copy of the communication form conforming to the model in annex 1 to this Regulation."

Paragraph 11. (former), renumber as paragraph 12.

Annex 1, amend to read:

"Annex 1

COMMUNICATION

(maximum format: A4 (210 x 297 mm))

issued by: Name of administration:
.....
.....
.....

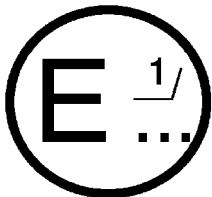

concerning: 2/ APPROVAL GRANTED
APPROVAL EXTENDED
APPROVAL REFUSED
APPROVAL WITHDRAWN
PRODUCTION DEFINITELY DISCONTINUED

of a moped type with regard to noise pursuant to Regulation No. 63.

Approval No: Extension No.:

1. Trade name or mark of the moped
2. Moped type
3. Variant(s) (if applicable):
4. Version(s) (if applicable):
5. Name and address of manufacturer:.....
6. Name and address of manufacturer's representative (if applicable):
.....
7. Type(s) of original exhaust system(s):
8. Type(s) of intake device(s) (if required in order to ensure conformity
with noise-level limits):
9. Kind of engine 3/
10. Cycles: 2-stroke or 4-stroke (if applicable) 2/.....

11. Cylinder capacity
 - 11.1. Bore mm
 - 11.2. Strokemm
12. Engine power (state how measured)
13. Engine speed at which maximum power is developedmin⁻¹
14. Number of gears
 - 14.1. gears used
 - 14.2. final drive ratio(s)
15. Type and dimensions of tyres
16. Maximum permissible gross weight kg
17. Maximum design speed (as indicated by the manufacturer)km/h
18.
- ...
25. Approval granted/refused/extended/withdrawn 2/
26. ...
- ...
30. ...

1/ Distinguishing number of the country which has granted/extended/refused/withdrawn approval (see approval conditions in the Regulation).

2/ Strike out what does not apply.

3/ If a non-conventional engine is used, this should be stated."

Annex 2

Examples of approval marks, models A and B, replace approval mark "002439" by "012439".

Model A, text following the example, replace approval number "002439" by "012439" and the words "in its original form" by "already included the 01 series of amendments".

Model B, text following the example, replace the words "had not been modified, but that Regulation No. 33 1/ included the 01 series of amendments" by "already included the 01 series of amendments and Regulation No. 33 1/ has also been amended by the 01 series of amendments".

Annex 3,

Add a new paragraph 1.1, to read:

"1.1. Acoustic measurements".

Paragraphs 1.1. to 1.3.(former), renumber as paragraphs 1.1.1. to 1.1.3. and amend to read:

"1.1.1. The apparatus used for measuring the sound level shall be a precision sound-level meter of the type described in International Electrotechnical Commission (IEC) publication No. 179 "Precision sound-level meters", second edition.

1.1.2. Measurements shall be carried out using the "fast" response of the sound-level meter and the "A" weighting also described in that publication.

1.1.3. At the beginning and end of each series of measurements the sound-level meter shall be calibrated in accordance with the manufacturer's instructions, using an appropriate sound source (e.g. pistonphone)."

Paragraph 1.4., renumber as paragraph 1.1.4.

Insert a new paragraph 1.2, to read:

"1.2. Speed measurements

Engine revolution and the speed of the moped on the test track shall be determined to within $\pm 3\%$."

Paragraph 2.1.1, amend to read:

"2.1.1. The test site shall consist of a central acceleration track surrounded by a substantially level test area. The test track shall be level; the track surface shall be dry and so designed that rolling noise remains low.

On the test site, free sound field conditions shall be maintained to within 1 dB between the sound source placed in the middle of the acceleration section and the microphone. This condition shall be deemed to be met if there are no large sound reflecting objects such as hedges, rocks, bridges or buildings within 50 metres of the

centre of the acceleration section.

No obstacle likely to affect the sound field shall be close to the microphone and no one shall come between the microphone and the sound source. The observer taking the measurements shall take up position so as to avoid influencing the metre readings."

Paragraph 2.1.2., amend to read:

"2.1.2. The surface of the test track shall conform to the requirements of annex 5."

Paragraph 2.1.3., amend to read:

"2.1.3. Miscellaneous

Measurements shall not be made in poor weather conditions. Precautions shall be taken to ensure that readings are not influenced by wind gusts.

For measurement purposes, the weighted sound-level (A) of sound sources on the test vehicle and the sound-level produced by the effect of the wind shall be at least 10 dB(A) below the noise-level produced by the vehicle. The microphone may be fitted with a suitable wind guard, provided that its influence on the sensitivity and directional characteristics of the microphone are taken into account.

If the difference between ambient and measured noise-levels is between 10 and 16 dB(A), the appropriate figure shall be subtracted from the value recorded by the sound-level metre, in accordance with the following graph:

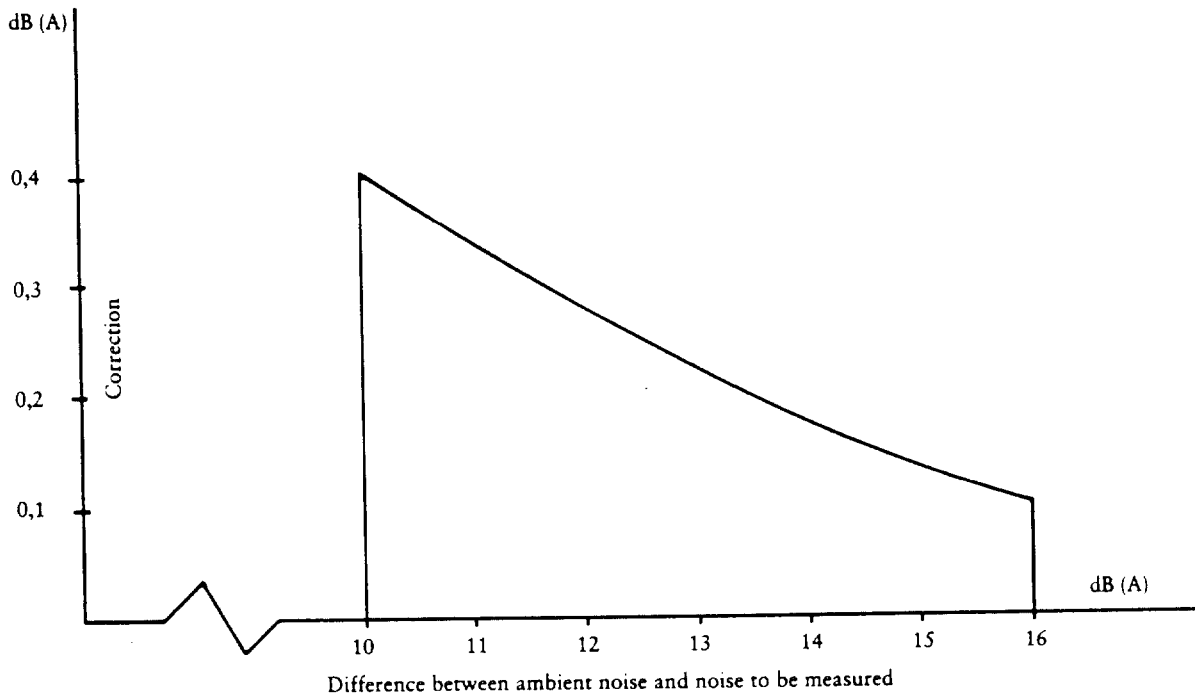

Paragraph 2.2.1., amend to read:

"... shall not be more than 90 kg, or less than 70 kg.

Weights shall be placed on the moped if the 70 kg minimum is not reached.

While measurements are being taken, the moped shall be equipped as for normal road use (with coolant, lubricants, fuel, tool kit, spare wheel and driver)."

Paragraph 3.1.1.3., amend to read:

"... out on the test track. The moped shall approach line AA' at an initial steady speed as specified below. When the front of the moped reaches line AA' the throttle shall be fully opened as quickly as practically possible and kept in that position until the rear of the moped reaches line BB'; the throttle must then be returned as quickly as possible to the idle position."

For all measurements, the moped shall be driven in a straight line along the test track in such a way that the track of the median longitudinal plane of the moped is as close as possible to the

line CC'."

Paragraphs 3.1.2.2.1. and 3.1.2.2.2., should be deleted.

Paragraph 3.1.2.2., amend to read:

"3.1.2.2. If the moped is fitted with a manually-operated gearbox, the highest gear shall be selected which enables it to pass over the line AA' with an engine speed above or equal to one half the engine speed at which the engine produces its maximum power."

Paragraph 3.1.2.3., amend to read:

"3.1.2.3. If the moped is fitted with automatic transmission, it shall be driven at the speeds indicated in 3.1.2.1."

Paragraph 3.2., amend to read:

"3.2. MEASUREMENT OF NOISE EMITTED BY STATIONARY MOPEDS (conditions and method of measurement for testing vehicles in service).

In addition, in order to facilitate subsequent testing of mopeds in service, the sound pressure level shall be measured close to the outlet of the exhaust (silencing) system, in accordance with the following requirements, and the reading shall be recorded in the test report prepared for the issue of the document referred to in annex 1.

The measurements shall be made using a precision sound-level metre conforming to the requirements of paragraph 1."

Paragraph 3.2.3.1., amend to read:

"3.2.3.1. Nature and number of measurements

The maximum sound level expressed in A-weighted decibels (dB(A)) must be measured during the period of operation laid down in paragraph 3.2.3.3.2.1. below."

Paragraph 3.2.3.2., amend to read:

"3.2.3.2. Position and preparation of the moped

Before the measurements are started, the moped engine shall be brought to its normal operating temperature. If the moped is equipped with automatic fans, no adjustment shall be made to them during the measurement of the noise level.

While measurements are being made, the gear lever shall be in neutral. If the transmission cannot be disconnected, the drive wheel of the moped should be allowed to run under no-load conditions by, for example, placing the moped on its stand."

Paragraph 3.2.3.3.2.1., amend to read:

"3.2.3.3.2.1. Engine speed shall be held steady at one of the following values:

$\frac{1}{2} S$, if S exceeds 5,000 rpm,

$\frac{3}{4} S$, if S does not exceed 5,000 rpm,

where S is the engine speed at which the engine produces its maximum power."

Paragraphs 4. to 4.2., replace by the following text:

"4. INTERPRETATION OF RESULTS FOR VEHICLES IN MOTION

The values taken shall be rounded off to the nearest whole decibel. If the figure following the decimal point is between 0 and 4, the total is rounded down and if between 5 and 9, it is rounded up.

Only the values of readings obtained from two consecutive measurements made on the same side of the vehicle and not differing by more than 2 dB(A) shall be accepted.

To allow for lack of precision in the readings, the result of each measurement shall be taken as equal to the value obtained, less 1 dB(A).

If the average of the four readings does not exceed the maximum permissible level for the category to which the tested vehicle belongs, the limit specified in paragraph 6.2.1.3. shall be deemed as being complied with. This average value shall constitute the test result."

Insert new paragraphs 5. to 5.3., to read:

- "5. ORIGINAL EXHAUST (SILENCING) SYSTEM
- 5.1. Requirements for silencers containing absorbent fibrous materials.
- 5.1.1. Fibrous absorbent material must be asbestos-free and may be used in the construction of silencers only if suitable devices ensure that the fibrous absorbent material is kept in place for the whole time that the silencer is being used and it meets the requirements of any one of sections 5.1.2., 5.1.3. or 5.1.4.
- 5.1.2. After removal of the fibrous material, the sound level must conform to the requirements of annex 4.
- 5.1.3. The fibrous absorbent material may not be placed in those parts of the silencer through which the exhaust gases pass and must conform to the following requirements:
- 5.1.3.1. The material shall be heated at a temperature of $650 \pm 5^\circ \text{C}$ for four hours in a furnace without reduction in the average length, diameter or bulk density of the fibre;
- 5.1.3.2. After heating at $650 \pm 5^\circ \text{C}$ for one hour in a furnace, at least 98% of the material must be retained in a sieve of nominal aperture size $250 \mu\text{m}$ conforming to ISO standard 3310/1 when tested in accordance with ISO standard 2599;
- 5.1.3.3. The loss in weight of the material must not exceed 10.5% after soaking for 24 hours at $90 \pm 5^\circ \text{C}$ in a synthetic condensate of the following composition:
- | | |
|--|-------|
| 1 N hydrobromic acid (HBr) | 10 ml |
| 1 N sulphuric acid (H_2SO_4) | 10 ml |
| Distilled water to make up to 1,000 ml | |
- Note: The material must be washed in distilled water and dried for one hour at 105°C before weighing.
- 5.1.4. Before the system is tested in accordance with paragraph 3.1., it must be put into a normal state for road use by one of the following methods:
- 5.1.4.1. Conditioning by continuous road operation.
- 5.1.4.1.1. The minimum distance to be completed during conditioning shall be 2,000 km.
- 5.1.4.1.2. $50\% \pm 10\%$ of this conditioning cycle shall consist of town driving and the remainder of long-distance runs; the continuous road cycle may be replaced by a corresponding test-track programme.
- 5.1.4.1.3. The two speed regimes must be alternated at least six times.

5.1.4.1.4. The complete test programme must include a minimum of 10 breaks of at least three hours' duration in order to reproduce the effects of cooling and condensation.

5.1.4.2. Conditioning by pulsation.

5.1.4.2.1. The exhaust system or components thereof must be fitted to the moped or to the engine.

In the former case, the moped must be mounted on a roller dynamometer. In the second case, the engine must be mounted on a test bench.

The test apparatus, a detailed diagram of which is shown in figure 3, shall be fitted at the outlet of the exhaust system. Any other apparatus providing equivalent results shall be acceptable.

5.1.4.2.2. The test equipment must be adjusted so that the flow of exhaust gases is alternately interrupted and restored 2,500 times by a rapid-action valve.

5.1.4.2.3. The valve must open when the exhaust gas back-pressure, measured at least 100 mm downstream of the intake flange, reaches a value of between 0.35 and 0.40 bar. Should such a figure be unattainable because of the engine characteristics, the valve must open when the gas back-pressure reaches a level equivalent to 90% of the maximum that can be measured before the engine stops. It must close when this pressure does not differ by more than 10% from its stabilized value with the valve open.

5.1.4.2.4. The time-delay switch must be set for the duration of exhaust gases calculated on the basis of the requirements of paragraph 5.1.4.2.3. above.

5.1.4.2.5. Engine speed must be 75% of the speed (S) at which the engine develops maximum power.

5.1.4.2.6. The power indicated by the dynamometer must be 50% of the full-throttle power measured at 75% of engine speed (S).

5.1.4.2.7. Any drainage holes must be closed off during the test.

5.1.4.2.8. The entire test must be completed within 48 hours. If necessary, a cooling period must be allowed after each hour.

5.1.4.3. Conditioning on a test bench

5.1.4.3.1. The exhaust system must be fitted to an engine representative of the type fitted to the moped for which the system is designed, and mounted on a test bench.

5.1.4.3.2. Conditioning shall consist of three cycles.

5.1.4.3.3. Each test-bench cycle must be followed by a break of at least six hours in order to reproduce the effects of cooling and

condensation.

5.1.4.3.4. Each test-bench cycle shall consist of six phases. The engine conditions for and the duration of each phase shall be:

Phase	Conditions	Duration of each phase (in minutes)
1	Idling	6
2	25% load at 75% of S	40
3	50% load at 75% of S	40
4	100% load at 75% of S	30
5	50% load at 100% of S	12
6	25% load at 100% of S	22
	Total time	2 hrs 30 mins

5.1.4.3.5. During this conditioning procedure, at the request of the manufacturer, the engine and the silencer may be cooled in order that the temperature recorded at a point not more than 100 mm from the exhaust gas outlet does not exceed that measured when the moped is running at 75% of S in top gear. The engine and/or moped speeds shall be determined to within $\pm 3\%$.

5.2. Diagram and markings

5.2.1. The diagram and a dimensioned cross section of the silencer shall be annexed to the document mentioned in Annex 1.

5.2.2. All original silencing systems shall be marked with clearly legible and indelible make and type references.

5.2.3. Any packaging of original replacements for exhaust or silencing systems shall be marked legibly with the words "original part" and the make and type reference integrated together with the "E" mark and also the reference of the country of origin.

5.3. Intake silencers

If the engine intake has to be fitted with an air filter and/or intake silencer in order to comply with the permissible sound level, the filter and/or silencer shall be regarded as part of the silencer and the requirements of paragraphs 5.1. and 5.2. shall also be applicable to them."

Annex 3 - Appendix

Insert a new figure 3 as follows:

"TEST APPARATUS FOR CONDITIONING BY PULSATION

Figure 3

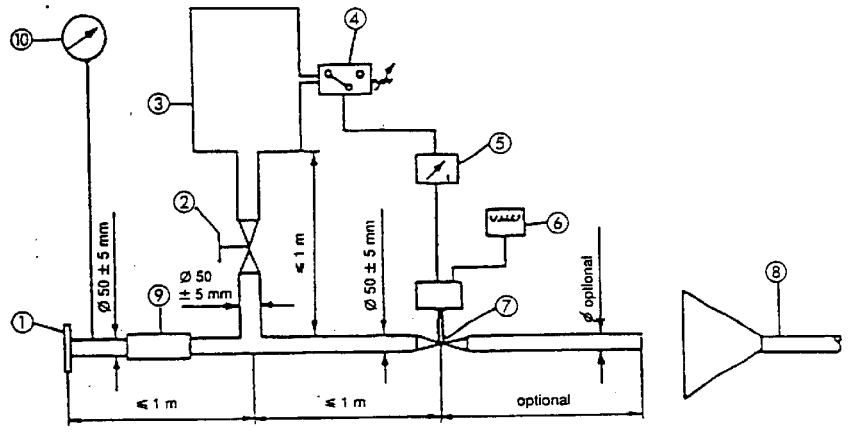

1. Inlet flange or sleeve for connection to the rear of the test exhaust system.

2. Hand-operated regulating valve.
3. Compensating reservoir with a maximum capacity of 40 l and a filling time of not less than one second.
4. Pressure switch with an operating range of 0.05 to 2.5 bar.
5. Time delay switch.
6. Pulse counter.
7. Quick-acting valve, such as exhaust brake valve 60 mm in diameter, operated by a pneumatic cylinder with an output of 120 N at 4 bar. The response time, both when opening and closing, must not exceed 0.5 seconds.
8. Exhaust gas evacuation.
9. Flexible pipe.
10. Pressure gauge."

Annex 4, table, amend to read:

Category of two-wheeled mopeds	Maximum noise-level values in dB(A)
≤ 25 km/h	66
> 25 km/h	71

Insert the following new Annex 5:

"Annex 5

SPECIFICATIONS FOR THE TEST SITE

1. Introduction

This annex describes the specifications relating to the physical characteristics and the laying of the test track. These specifications, based on a special standard, 1/ describe the required physical characteristics as well as the test methods for these characteristics.

2. Required characteristics of the surface

A surface is considered to conform to this standard provided that the texture and voids content or sound absorption coefficient have been measured and found to fulfil [all] the requirements of paragraphs 2.1. to 2.4. below and provided that the design requirements (para. 3.2.) have been met.

2.1. Residual voids content

The residual voids content, V_c , of the test track paving mixture shall not exceed 8%. For the measurement procedure, see paragraph 4.1.

2.2. Sound absorption coefficient

If the surface fails to conform to the residual voids content requirement, the surface is acceptable only if its sound absorption coefficient, α , ≤ 0.10 . For the measurement procedure, see paragraph 4.2. The requirement of paragraphs 2.1. and 2.2. is met also if only sound absorption has been measured and found to be $\alpha \leq 0.10$.

Note: The most relevant characteristic is the sound absorption, although the residual voids content is more familiar among road constructors. However, sound absorption needs to be measured only if the surface fails to conform to the voids requirement. This is because the latter is connected with relatively large uncertainties in terms of both measurements and relevance and some surfaces may therefore be rejected erroneously when the voids measurement only is used as a basis.

2.3. Texture depth

The texture depth (TD) measured according to the volumetric method (see para. 4.3. below) shall be:

$$TD \geq 0.4 \text{ mm}$$

2.4. Homogeneity of the surface

Every practical effort shall be taken to ensure that the surface is made to be as homogeneous as possible within the test area. This includes the texture and voids content, but it should also be observed that if the rolling process results in more effective rolling at some places than others, the texture may be different and unevenness causing bumps may also occur.

2.5. Period of testing

In order to check whether the surface continues to conform to the texture and voids content or sound absorption requirements stipulated in this standard, periodic testing of the surface shall be done at the following intervals:

(a) For residual voids content or sound absorption:

when the surface is new;
if the surface meets the requirements when new, no further
periodical testing is required. If it does not meet the
requirement when it is new, it may do later because surfaces
tend to become clogged and compacted with time.

(b) For texture depth (TD):

when the surface is new;
when the noise testing starts (NB: not before four weeks after
laying);
then every 12 months.

3. Test surface design

3.1. Area

When designing the test track layout it is important to ensure that, as a minimum requirement, the area traversed by the vehicles running through the test strip is covered with the specified test material with suitable margins for safe and practical driving. This will require that the width of the track is at least 3 m and the length of the track extends beyond lines AA and BB by at least 10 m at either end. Figure 1 shows a plan of a suitable test site and indicates the minimum area which shall be machine laid and machine compacted with the specified test surface material. According to annex 3, paragraph 3.1.1.1., measurements have to be made on each side of the vehicle. This can be made either by measuring with two microphone locations (one on each side of the track) and driving in one direction, or measuring with a microphone only on one side of the track but driving the vehicle in two directions. If the former method is used, then there are no surface requirements on that side of the track where there is no microphone.

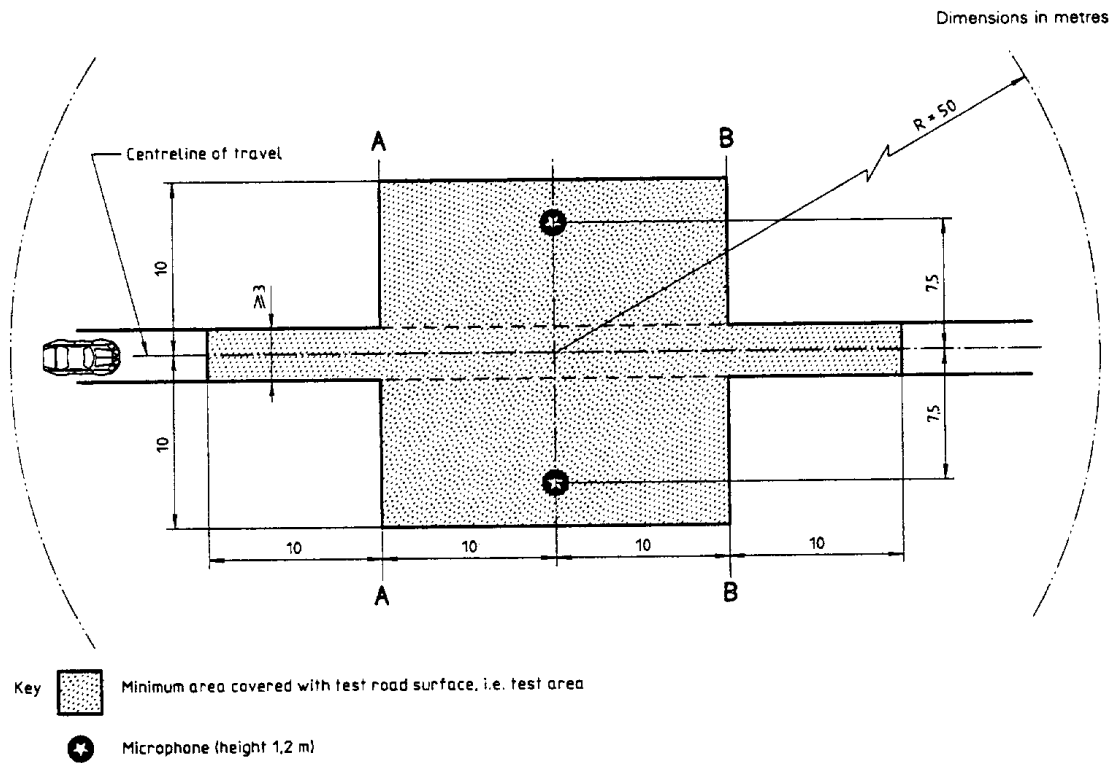

NOTE — There shall be no large acoustically reflective objects within this radius.

Minimum requirements for test surface area.
 The shaded part is called "Test Area".

3.2. Design and preparation of the surface

3.2.1. Basic design requirements

The test surface shall meet four design requirements:

- 3.2.1.1. It shall be a dense asphaltic concrete.
- 3.2.1.2. The maximum chipping size shall be 8 mm (tolerances allow from 6.3 to 10 mm).
- 3.2.1.3. The thickness of the wearing course shall be ≥ 30 mm.
- 3.2.1.4. The binder shall be a straight penetration grade bitumen without modification.

3.2.2. Design guidelines

As a guide to the surface constructor, an aggregate grading curve

which will give desired characteristics is shown in Figure 2. In addition, Table 1 gives some guidelines in order to obtain the desired texture and durability. The grading curve fits the following formula:

$$P (\% \text{ passing}) = 100 \cdot (d/d_{\max})^{1/2}$$

where: d = square mesh sieve size, in mm
 $d_{\max} = 8 \text{ mm}$ for the mean curve
 $d_{\max} = 10 \text{ mm}$ for the lower tolerance curve
 $d_{\max} = 6.3 \text{ mm}$ for the upper tolerance curve

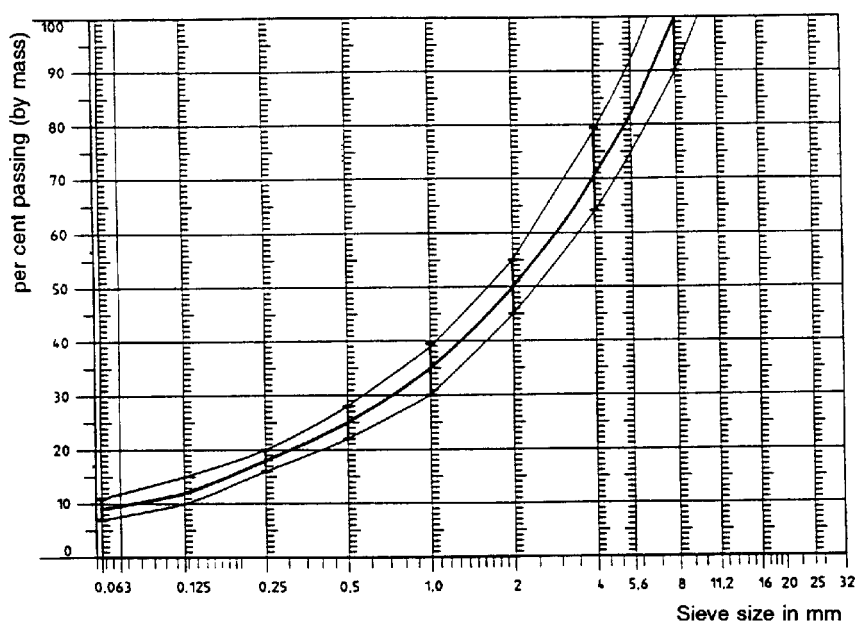

Figure 2: Grading curve of the aggregate in the asphaltic mix with tolerances.

In addition to the above, the following recommendations are given:

The sand fraction (0.063 mm < square mesh sieve size < 2mm) shall include no more than 55% natural sand and at least 45% crushed sand;

The base and sub-base shall ensure a good stability and evenness, according to best road construction practice;

The chippings shall be crushed (100% crushed faces) and of a material with a high resistance to crushing;

The chippings used in the mix shall be washed;

No extra chippings shall be added onto the surface;

The binder hardness expressed as PEN value shall be 40-60, 60-80 or even 80-100 depending on the climatic conditions of the country. The rule is that as hard a binder as possible shall be used, provided this is consistent with common practice;

The temperature of the mix before rolling shall be chosen so as to achieve by subsequent rolling the required voids content. In order to increase the probability of satisfying the specifications of paragraphs 2.1. to 2.4. above, the compactness shall be studied not only by an appropriate choice of mixing temperature, but also by an appropriate number of passings and by the choice of compacting vehicle.

Table 1: Design guidelines

	Target values		Tolerances
	By total mass of mix	By mass of the aggregate	
Mass of stones, square mesh sieve (SM) > 2 mm	47.6%	50.5%	± 5
Mass of sand 0.063 < SM < 2 mm	38.0%	40.2%	± 5
Mass of filler SM < 0.063 mm	8.8%	9.3%	± 2
Mass of binder (bitumen)	5.8%	N. A.	± 0.5
Max. chipping size	8 mm		6.3 - 10
Binder hardness	(see para. 3.2.2. (f))		
Polished stone value (PSV)	> 50		
Compactness, relative to Marshall compactness	98%		

4. Test method

4.1. Measurement of the residual voids content

For the purpose of this measurement, cores have to be taken from the track in at least four different positions which are equally distributed in the test area between lines AA and BB (see Figure 1). In order to avoid inhomogeneity and unevenness in the wheel tracks, cores should not be taken in wheel tracks themselves, but close to them. Two cores (minimum) should be taken close to the wheel tracks and one core (minimum) should be taken approximately midway between the wheel tracks and each microphone location.

If there is a suspicion that the condition of homogeneity is not met (see para. 2.4.), cores shall be taken from more locations within the

test area. The residual voids content has to be determined for each core, then the average value from all cores shall be calculated and compared with the requirement of paragraph 2.1. In addition, no single core shall have a voids value which is higher than 10%. The test surface constructor is reminded of the problem which may arise when the test area is heated by pipes or electrical wires and cores must be taken from this area. Such installations must be carefully planned with respect to future core drilling locations. It is recommended to leave a few locations of size approximately 200 x 300 mm where there are no wires/pipes or where the latter are located deep enough in order not to be damaged by cores taken from the surface layer.

4.2. Sound absorption coefficient

The sound absorption coefficient (normal incidence) shall be measured by the impedance tube method using the procedure specified in ISO/DIS 10 534: "Acoustics - Determination of sound absorption coefficient and impedance by a tube method."

Regarding test specimens, the same requirements shall be followed as regarding the residual voids content (see para. 4.1.). The sound absorption shall be measured in the range between 400 Hz and 800 Hz and in the range between 800 Hz and 1,600 Hz (at least at the centre frequencies of third octave bands) and the maximum values shall be identified for both of these frequency ranges. Then these values, for all test cores, shall be averaged to constitute the final result.

4.3. Volumetric macrottexture measurement

For the purpose of this standard, texture depth measurements shall be made on at least 10 positions evenly spaced along the wheel tracks of the test strip and the average value taken to compare with the specified minimum texture depth. For the description of the procedure see standard ISO 10844:1994.

5. Stability in time and maintenance

5.1. Age influence

In common with any other surfaces, it is expected that the tyre/road noise level measured on the test surface may increase slightly during the first 6-12 months after construction.

The surface will achieve its required characteristics not earlier than four weeks after construction. The influence of age on the noise from trucks is generally less than that from cars.

The stability over time is determined mainly by the polishing and compaction by vehicles driving on the surface. It shall be periodically checked as stated in paragraph 2.5.

5.2. Maintenance of the surface

Loose debris or dust which could significantly reduce the effective texture depth must be removed from the surface. In countries with winter climates, salt is sometimes used for de-icing. Salt may alter

the surface temporarily or even permanently in such a way as to increase noise and is therefore not recommended.

5.3. Repaving the test area

If it is necessary to repave the test track, it is usually unnecessary to repave more than the test strip (of 3 m width in Figure 1) where vehicles are driving, provided the test area outside the strip met the requirement of residual voids content or sound absorption when it was measured.

6. Documentation of the test surface and of tests performed on it

6.1. Documentation of the test surface

The following data shall be given in a document describing the test surface:

6.1.1. The location of the test track.

6.1.2. Type of binder, binder hardness, type of aggregate, maximum theoretical density of the concrete (D_R), thickness of the wearing course and grading curve determined from cores from the test track.

6.1.3. Method of compaction (e.g. type of roller, roller mass, number of passes).

6.1.4. Temperature of the mix, temperature of the ambient air and wind speed during laying of the surface.

6.1.5. Date when the surface was laid and contractor.

6.1.6. All or at least the latest test results, including:

6.1.6.1. The residual voids content of each core.

6.1.6.2. The locations in the test area from where the cores for voids measurements have been taken.

6.1.6.3. The sound absorption coefficient of each core (if measured). Specify the results both for each core and each frequency range as well as the overall average.

6.1.6.4. The locations in the test area from where the cores for absorption measurement have been taken.

6.1.6.5. Texture depth, including the number of tests and standard deviation.

6.1.6.6. The institution responsible for tests according to paragraphs 6.1.6.1. and 6.1.6.2. and the type of equipment used.

6.1.6.7. Date of the test(s) and date when the cores were taken from the test track.

6.2. Documentation of vehicle noise tests conducted on the surface

In the document describing the vehicle noise test(s) it shall be

stated whether all the requirements of this standard were fulfilled or not. Reference shall be given to a document according to paragraph 6.1. describing the results which verify this."
