

25 January 2011

Agreement

Concerning the Adoption of Uniform Technical Prescriptions for Wheeled Vehicles, Equipment and Parts which can be Fitted and/or be Used on Wheeled Vehicles and the Conditions for Reciprocal Recognition of Approvals Granted on the Basis of these Prescriptions*

(Revision 2, including the amendments which entered into force on 16 October 1995)

Addendum 52: Regulation No. 53

Revision 2 – Amendment 3

Supplement 11 to the 01 series of amendments - Date of entry into force: 9 December 2010

Uniform provisions concerning the approval of category L₃ vehicles with regard to the installation of lighting and light-signalling devices



UNITED NATIONS

* Former title of the Agreement: Agreement Concerning the Adoption of Uniform Conditions of Approval and Reciprocal Recognition of Approval for Motor Vehicle Equipment and Parts, done at Geneva on 20 March 1958.

Table of contents, list of Annexes, add a reference to a new Annex 6, to read:

- "6 Explanation about "the horizontal inclination", "the bank angle" and the angle " δ " "

The text of the Regulation,

Insert new paragraphs 2.24. to 2.29., to read:

- "2.24. "Horizontal inclination" means the angle created between the beam pattern when the motorcycle is set as specified in paragraph 5.4., and the beam pattern when the motorcycle is banked (see drawing in Annex 6);
- 2.25. "Horizontal inclination adjustment system (HIAS)" means a device that adjusts the horizontal inclination of the headlamp towards zero;
- 2.26. "Bank angle" means: the angle made with the vertical by the vertical longitudinal median plane of the motorcycle, when the motorcycle is rotated about its longitudinal axis (see drawing in Annex 6);
- 2.27. "HIAS signal" means any control signal or, any additional control input to the system or, a control output from the system to the motorcycle;
- 2.28. "HIAS signal generator" means a device, reproducing one or more of the HIAS signals for system test;
- 2.29. "HIAS test angle" means the angle δ created by the headlamp cut-off line and HH line (in case of an asymmetrical beam headlamp, the horizontal part of the cut-off shall be used), (see drawing in Annex 6)."

Paragraphs 6.1.5. to 6.1.5.2., amend to read:

- "6.1.5. *Orientation*
- 6.1.5.1. Forwards. The lamp(s) may move with the steering angle.
- 6.1.5.2. An HIAS may be installed for the driving beam."

Paragraphs 6.1.8. to 6.1.8.2., amend to read:

- "6.1.8. *Tell-tales*
- 6.1.8.1. "Circuit-closed" tell-tale.
Mandatory, non-flashing blue signal lamp.
- 6.1.8.2. "HIAS failure" tell-tale
Mandatory, flashing amber signal lamp, which may be combined with the tell-tale referred to in paragraph 6.2.8.2. It shall be activated whenever a failure is detected with respect to the HIAS signals. It shall remain activated while the failure is present."

Paragraph 6.1.9, amend to read:

- "6.1.9. *Other requirements*
- 6.1.9.1. The aggregate maximum intensity of the driving beam headlamps which can be switched on simultaneously shall not exceed 430,000 cd which corresponds to a reference number of 100. (The approval value)."

Insert a new paragraph 6.1.9.2., to read:

- "6.1.9.2. In the event of a driving beam HIAS failure, without the use of any special tools, it shall be possible to:

- (a) Deactivate the HIAS until it is reset according to the manufacturers instructions; and
- (b) Re-position the driving beam so that its horizontal and vertical alignments are the same as a headlamp not equipped with HIAS.

The manufacturer shall provide a detailed description of the procedure for resetting the HIAS.

Alternatively, the manufacturer may choose to install an automatic system that either achieves both the tasks specified above or resets the HIAS. In this case, the manufacture shall provide the test house with a description of the automatic system and, until such time as harmonized requirements have been developed, demonstrate the means of verifying that the automatic system works as described."

Insert new paragraphs 6.2.5.5. to 6.2.5.6., to read:

"6.2.5.5. An HIAS may be installed for the passing beam. The HIAS shall not adjust the horizontal inclination by more than the vehicle's bank angle.

6.2.5.6. The requirement in paragraph 6.2.5.5. shall be tested under the following conditions:

The test vehicle shall be set as specified in paragraph 5.4. Incline the vehicle and measure the HIAS test angle.

The vehicle shall be tested in the following two conditions:

- (a) The maximum horizontal inclination adjustment angle specified by the manufacturer (to left and to right);
- (b) Half of the maximum horizontal inclination adjustment angle specified by the manufacturer (to left and to right).

And when the test vehicle is returned to the position as specified in paragraph 5.4., the HIAS test angle shall return to zero quickly.

The handlebar may be fixed in the straight ahead position so as not to move during the vehicle inclination.

For the test the HIAS shall be activated by means of an HIAS signal generator.

The system shall be considered to satisfy the requirements of paragraph 6.2.5.5., if all measured HIAS test angles are not less than zero. This may be demonstrated by the manufacturer using other means accepted by the authority responsible for type approval."

Paragraphs 6.2.8. to 6.2.9., amend to read:

"6.2.8. *Tell-tales*

6.2.8.1. "Circuit-closed" tell-tale.

Optional; non-flashing green signal lamp.

6.2.8.2. "HIAS failure" tell-tale.

Mandatory, flashing amber signal lamp, which may be combined with the tell-tale referred to in paragraph 6.1.8.2. It shall be activated whenever a failure is detected with respect to the HIAS signals. It shall remain activated while the failure is present."

6.2.9. *Other requirements*

In the event of a passing beam HIAS failure, without the use of any special tools, it shall be possible to:

- (a) Deactivate the HIAS until it is reset according to the manufacturers instructions; and
- (b) Re-position the passing beam so that its horizontal and vertical alignments are the same as a headlamp not equipped with HIAS.

The manufacturer shall provide a detailed description of the procedure for resetting the HIAS.

Alternatively, the manufacturer may choose to install an automatic system that either achieves both tasks specified above or resets the HIAS. In this case, the manufacture shall provide the test house with a description of the automatic system and, until such time as harmonized requirements have been developed, demonstrate the means of verifying that the automatic system works as described."

Paragraph 6.13.4.1.4., amend to read:

"6.13.4.1.4. In the case of two daytime running lamps, the distance separating the illuminating surfaces shall not exceed 420 mm."

Insert a new paragraph 6.13.4.1.5., to read:

"6.13.4.1.5. The maximum separation distance is not applicable when the daytime running lamps:

- (a) Are grouped, combined or reciprocally incorporated with another headlamp, or
- (b) Are within the projection of the frontal silhouette of the motorcycle on an orthogonal plane perpendicular to the longitudinal median plane of the vehicle."

Insert a new Annex 6, to read:

"Annex 6

Explanation about "the horizontal inclination", "the bank angle" and the angle " δ ".

Figure 3

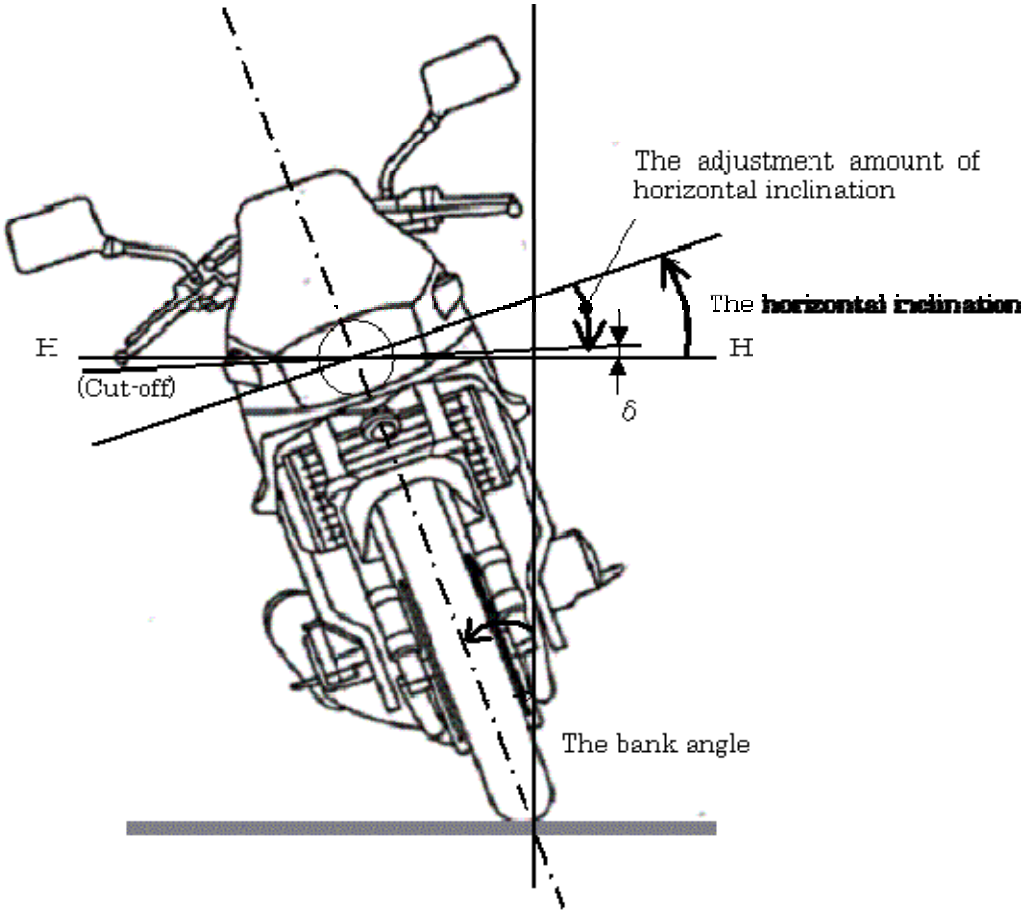

Note: This figure shows the motorcycle is banked to the right side."