

22 May 2018

---

## **Agreement**

### **Concerning the Adoption of Harmonized Technical United Nations Regulations for Wheeled Vehicles, Equipment and Parts which can be Fitted and/or be Used on Wheeled Vehicles and the Conditions for Reciprocal Recognition of Approvals Granted on the Basis of these United Nations Regulations\***

(Revision 3, including the amendments which entered into force on 14 September 2017)

---

### **Addendum 77: UN Regulation No. 78**

#### **Revision 2**

Incorporating all valid text up to:

Erratum to Revision 1

Corrigendum 1 to the 03 series of amendments - Date of entry into force: 12 March 2008

Supplement 1 to the 03 series of amendments - Date of entry into force: 26 February 2009

Corrigendum 2 to the 03 series of amendments - Date of entry into force: 23 June 2010

Supplement 2 to the 03 series of amendments – Date of entry into force: 8 October 2015

Supplement 3 to the 03 series of amendments – Date of entry into force: 9 February 2017

04 series of amendments – Date of entry into force: 22 June 2017

#### **Uniform provisions concerning the approval of vehicles of categories L<sub>1</sub>, L<sub>2</sub>, L<sub>3</sub>, L<sub>4</sub> and L<sub>5</sub> with regard to braking**



**UNITED NATIONS**

---

\* Former titles of the Agreement:

Agreement concerning the Adoption of Uniform Conditions of Approval and Reciprocal Recognition of Approval for Motor Vehicle Equipment and Parts, done at Geneva on 20 March 1958 (original version); Agreement concerning the Adoption of Uniform Technical Prescriptions for Wheeled Vehicles, Equipment and Parts which can be Fitted and/or be Used on Wheeled Vehicles and the Conditions for Reciprocal Recognition of Approvals Granted on the Basis of these Prescriptions, done at Geneva on 5 October 1995 (Revision 2).

This document is meant purely as documentation tool. The authentic and legal binding texts are: ECE/TRANS/WP.29/2008/4, ECE/TRANS/WP.29/2008/64, s amended by paragraph 38 of the report ECE/TRANS/WP.29/1068, ECE/TRANS/WP.29/2010/68, ECE/TRANS/WP.29/2015/9, as amended by paragraph 57 of the report ECE/TRANS/WP.29/1114, ECE/TRANS/WP.29/2016/56 as amended by paragraph 59 of the report ECE/TRANS/WP.29/1123 and ECE/TRANS/WP.29/2016/114, as amended by paragraph 83 of the report ECE/TRANS/WP.29/1126.

## UN Regulation No. 78

### Uniform provisions concerning the approval of vehicles of categories L<sub>1</sub>, L<sub>2</sub>, L<sub>3</sub>, L<sub>4</sub> and L<sub>5</sub> with regard to braking

Contents		<i>Page</i>
Regulation		
1.	Scope .....	4
2.	Definitions .....	4
3.	Application for approval .....	6
4.	Approval .....	7
5.	Specifications .....	8
6.	Tests .....	12
7.	Modifications of vehicle type or braking system and extension of approval .....	13
8.	Conformity of production .....	13
9.	Transitional provisions .....	14
10.	Penalties for non-conformity of production .....	14
11.	Production definitively discontinued .....	15
12.	Names and addresses of Technical Services responsible for conducting approval tests and of Type Approval Authorities .....	15
Annexes		
1	Communication concerning the approval or extension or refusal or withdrawal of approval or production definitively discontinued of a type of vehicle of category L with regard to braking pursuant to UN Regulation No. 78 .....	16
	Appendix: List of vehicle data for the purpose of UN Regulation No. 90 approvals .....	18
2	Arrangements of approval marks .....	19
3	Test conditions, procedures and performance requirements .....	20

## 1. Scope

This Regulation applies to vehicles of category L.<sup>1</sup>

These categories do not include:

- (a) Vehicles with a Vmax of < 25 km/h;
- (b) Vehicles equipped for disabled riders.

## 2. Definitions

For the purposes of this Regulation:

- 2.1. "*Antilock Brake System (ABS)*" means a system which senses wheel slip and automatically modulates the pressure producing the braking forces at the wheel(s) to limit the degree of wheel slip.
- 2.2. "*Approval of a vehicle*" means the approval of a vehicle type with regard to braking.
- 2.3. "*Baseline test*" means a stop or a series of stops carried out in order to confirm the performance of the brake prior to subjecting it to a further test such as the heating procedure or wet brake stop.
- 2.4. "*Brake*" means those parts of the brake system where the forces opposing the movement of the vehicle are developed.
- 2.5. "*Brake system*" means the combination of parts consisting of the control, transmission, and brake, but excluding the engine, whose function it is to progressively reduce the speed of a moving vehicle, bring it to a halt, and keep it stationary when halted.
- 2.6. "*Combined brake system (CBS)*" means:
  - For vehicle categories L<sub>1</sub> and L<sub>3</sub>: a service brake system where at least two brakes on different wheels are operated by the actuation of a single control.
  - For vehicle categories L<sub>2</sub>, L<sub>5</sub>, L<sub>6</sub> and L<sub>7</sub>: a service brake system where the brakes on all wheels are operated by the actuation of a single control.
  - For vehicle category L<sub>4</sub>: a service brake system where the brakes on at least the front and rear wheels are operated by the actuation of a single control. (If the rear wheel and sidecar wheel are braked by the same brake system, this is regarded as the rear brake.)
- 2.7. "*Components of the braking system*" means one of the individual parts which, when assembled, constitute the braking system.
- 2.8. "*Control*" means the part actuated directly by the rider in order to supply or control the energy required for braking the vehicle to the transmission.
- 2.9. "*Different types of braking systems*" means devices which differ in such essential respects as:

---

<sup>1</sup> As defined in the Consolidated Resolution on the Construction of Vehicles (R.E.3), document ECE/TRANS/WP.29/78/Rev.6, para. 2 - [www.unece.org/trans/main/wp29/wgs/wp29gen/wp29resolutions.html](http://www.unece.org/trans/main/wp29/wgs/wp29gen/wp29resolutions.html)

- (a) Components having different characteristics;
  - (b) A component made of materials having different characteristics, or a component differing in shape or size;
  - (c) A different assembly of the components.
- 2.10. "*Driver mass*" means the nominal mass of a driver that shall be 75 kg (subdivided into 68 kg occupant mass at the seat and 7 kg luggage mass).
- 2.11. "*Engine disconnected*" means when the engine is no longer connected to the driving wheel(s).
- 2.12. "*Gross vehicle mass*" or "*maximum mass*" means the technically permissible maximum laden mass as declared by the manufacturer.
- 2.13. "*Initial brake temperature*" means the temperature of the hottest brake before any brake application.
- 2.14. "*Laden*" means so loaded as to attain the gross vehicle mass as defined in paragraph 2.12.
- 2.15. "*Lightly loaded*" means mass in running order plus 15 kg for test equipment, or the laden condition, whichever is less. In the case of ABS tests on a low friction surface (Annex 3, paragraphs 9.4. to 9.7.), the mass for test equipment is increased to 30 kg to account for outriggers.
- 2.16. "*Mass in running order*" means the sum of the unladen vehicle mass and driver mass.
- 2.17. "*Peak braking coefficient (PBC)*" means the measure of tyre to road surface friction based on the maximum deceleration of a rolling tyre.
- 2.18. "*Power-assisted braking system*" means a brake system in which the energy necessary to produce the braking force is supplied by the physical effort of the rider assisted by one or more energy supplying devices, for example vacuum assisted (with vacuum booster).
- 2.19. "*Secondary brake system*" means the second service brake system on a vehicle equipped with a combined brake system.
- 2.20. "*Service brake system*" means a brake system which is used for slowing the vehicle when in motion.
- 2.21. "*Single brake system*" means a brake system which acts on only one axle.
- 2.22. "*Split service brake system (SSBS)*" means a brake system that operates the brakes on all wheels, consisting of two or more subsystems actuated by a single control designed so that a single failure in any subsystem (such as a leakage type failure of a hydraulic subsystem) does not impair the operation of any other subsystem.
- 2.23. "*Stopping distance*" means the distance travelled by the vehicle from the point the rider begins to actuate the brake control to the point at which the vehicle reaches a full stop. For tests where the simultaneous actuation of two controls is specified, the distance travelled is taken from the point the first control is actuated.
- 2.24. "*Test speed*" means the vehicle speed measured the moment the driver begins to actuate the brake control(s). For tests where the simultaneous actuation of two controls is specified, the vehicle speed is taken from the point the first control is actuated.

- 2.25. "Transmission" means the combination of components that provide the functional link between the control and the brake.
- 2.26. "Unladen vehicle mass" means the nominal mass of the vehicle as indicated by the manufacturer(s) including all factory fitted equipment for normal operation of that vehicle (e.g. fire extinguisher, tools, spare wheel), plus coolant, oils, 90 per cent of fuel and 100 per cent of other gas or liquids, as specified by the manufacturer.
- 2.27. "Vehicle type" means a sub-category of L-category vehicles which do not differ in such essential respects as:
- (a) The vehicle category, as defined in the Consolidated Resolution (R.E.3);
  - (b) The gross vehicle mass, as defined in paragraph 2.12.;
  - (c) The distribution of the mass between the axles;
  - (d) Vmax;
  - (e) A different type of braking device;
  - (f) The number and arrangement of the axles;
  - (g) The engine type;
  - (h) The number and ratios of gears;
  - (i) The final drive ratios;
  - (j) The tyre dimensions.
- 2.28. "Vmax" means either the speed attainable by accelerating at a maximum rate from a standing start for a distance of 1.6 km on a level surface, with the vehicle lightly loaded, or the speed measured in accordance with ISO 7117:1995.
- 2.29. "Wheel lock" means the condition that occurs when there is a slip ratio of 1.00.
- 2.30. "Emergency braking signal" means logic signal indicating emergency braking specified in paragraphs 5.1.15. to 5.1.15.2. of this Regulation.

### **3. Application for approval**

- 3.1. The application for approval of a vehicle type with regard to braking shall be submitted by the vehicle manufacturer or by his duly accredited representative.
- 3.2. It shall be accompanied by the under mentioned documents in triplicate and by the following particulars:
- 3.2.1. A description of the vehicle type with regard to the items specified in paragraph 2.27. The numbers and/or symbols identifying the vehicle type and the engine type shall be specified;
  - 3.2.2. A list of components, duly identified, constituting the braking device;
  - 3.2.3. A diagram of the assembled braking system and an indication of the position of its components on the vehicle;

- 3.2.4. Detailed drawings of each component to enable it to be easily located and identified.
- 3.3. A vehicle, representative of the vehicle type to be approved, shall be submitted to the Technical Service responsible for conducting the approval tests.

## **4. Approval**

- 4.1. If the vehicle type submitted for approval pursuant to this Regulation meets the requirements of paragraphs 5. and 6. below, approval of that vehicle type shall be granted.
- 4.2. An approval number shall be assigned to each type approved. Its first two digits (at present 04 corresponding to the 04 series of amendments) shall indicate the series of amendments incorporating the most recent major technical amendments made to the Regulation at the time of issue of the approval. The same Contracting Party shall not assign the same number to the same vehicle type equipped with another type of braking device, or to another vehicle type.
- 4.3. Notice of approval or refusal or extension or withdrawal of approval or production definitively discontinued of a vehicle type pursuant to this Regulation shall be communicated to the Parties to the Agreement which apply this Regulation by means of a form conforming to the model in Annex 1 to this Regulation.
- 4.4. There shall be affixed, conspicuously and in a readily accessible place specified on the approval form, to every vehicle conforming to a vehicle type approved under this Regulation an international approval mark consisting of:
- 4.4.1. A circle surrounding the letter "E" followed by the distinguishing number of the country which has granted approval;<sup>2</sup>
- 4.4.2. The number of this Regulation, followed by the letter "R", a dash and the approval number to the right of the circle prescribed in paragraph 4.4.1.
- 4.5. If the vehicle conforms to a vehicle type approved, under one or more other Regulations annexed to the Agreement, in the country which has granted approval under this Regulation, the symbol prescribed in paragraph 4.4.1. needs not be repeated; in such a case, the Regulation and approval numbers and the additional symbols of all the Regulations under which approval has been granted in the country which has granted approval under this Regulation shall be placed in vertical columns to the right of the symbol prescribed in paragraph 4.4.1.
- 4.6. The approval mark shall be clearly legible and be indelible.
- 4.7. The approval mark shall be placed close to or on the vehicle data plate affixed by the manufacturer.

---

<sup>2</sup> The distinguishing numbers of the Contracting Parties to the 1958 Agreement are reproduced in Annex 3 to the Consolidated Resolution on the Construction of Vehicles (R.E.3), document ECE/TRANS/WP.29/78/Rev.6, Annex 3 - [www.unece.org/trans/main/wp29/wp29wgs/wp29gen/wp29resolutions.html](http://www.unece.org/trans/main/wp29/wp29wgs/wp29gen/wp29resolutions.html)

- 4.8. Annex 2 to this Regulation gives examples of arrangements of approval marks.

## 5. Specifications

- 5.1. Brake system requirements

- 5.1.1. Each vehicle shall meet each of the tests specified for a vehicle of its category and for those brake features on the vehicle.

- 5.1.2. Service brake system control operation

Vehicles shall have configurations that enable a rider to actuate the service brake system control while seated in the normal driving position and with both hands on the steering control.

- 5.1.3. Secondary brake system control operation

Vehicles shall have configurations that enable a rider to actuate the secondary brake system control while seated in the normal driving position and with at least one hand on the steering control.

- 5.1.4. Parking brake system

If a parking brake system is fitted, it shall hold the vehicle stationary on the slope prescribed in paragraph 1.1.4. of Annex 3.

The parking brake system shall:

- (a) Have a control which is separate from the service brake system controls; and
- (b) Be held in the locked position by solely mechanical means.

Vehicles shall have configurations that enable a rider to be able to actuate the parking brake system while seated in the normal driving position.

For L<sub>2</sub>, L<sub>4</sub>, L<sub>5</sub>, L<sub>6</sub> and L<sub>7</sub>, the parking brake system shall be tested in accordance with paragraph 8. of Annex 3.

- 5.1.5. Two-wheeled vehicles of categories L<sub>1</sub> and L<sub>3</sub> shall be equipped with either two separate service brake systems, or a split service brake system, with at least one brake operating on the front wheel and at least one brake operating on the rear wheel.

- 5.1.6. Three-wheeled vehicles of vehicles category L<sub>4</sub> shall comply with the brake system requirements set out in paragraph 5.1.5. A brake on the sidecar wheel is not required if the vehicle meets the performance requirements prescribed in Annex 3.

- 5.1.7. Three-wheeled vehicles of category L<sub>2</sub> and four-wheeled vehicles of category L<sub>6</sub> shall be equipped with a parking brake system plus one of the following service brake systems:

- (a) Two separate service brake systems, except CBS, which, when applied together, operate the brakes on all wheels; or
- (b) A split service brake system; or
- (c) A CBS that operates the brakes on all wheels and a secondary brake system which may be the parking brake system.



- 5.1.8. Category L<sub>5</sub> vehicles and category L<sub>7</sub> vehicles shall be equipped with:
- 5.1.8.1. A parking brake system; and
- 5.1.8.2. A foot-actuated service brake system which operates on the brakes on all wheels, by way of either:
- (a) A split service brake system; or
  - (b) A CBS that operates the brakes on all wheels and a secondary brake system, which may be the parking brake system.
- 5.1.9. In cases where two separate service brake systems are installed, the systems may share a common brake, a common transmission, or both if the requirements of Annex 3, paragraph 12. are met.
- 5.1.10. For vehicles that use hydraulic fluid for brake force transmission, the master cylinder shall:
- (a) Have a sealed, covered, separate reservoir for each brake system;
  - (b) Have a minimum reservoir capacity equivalent to 1.5 times the total fluid displacement required to satisfy the new to fully worn lining condition with the worst case brake adjustment condition; and
  - (c) Have a reservoir where the fluid level is visible for checking without removal of the cover.
- 5.1.11. All warning lamps shall be mounted in the rider's view.
- 5.1.12. Vehicles that are equipped with a split service brake system shall be fitted with a red warning lamp, which shall be activated:
- (a) When there is a hydraulic failure on the application of a force of  $\leq 90$  N on the control; or
  - (b) Without actuation of the brake control, when the brake fluid level in the master cylinder reservoir falls below the greater of:
    - (i) That which is specified by the manufacturer; and
    - (ii) That which is less than or equal to half of the fluid reservoir capacity.
- To permit function checking, the warning lamp shall be illuminated by the activation of the ignition switch and shall be extinguished when the check has been completed. The warning lamp shall remain on while a failure condition exists whenever the ignition switch is in the "on" position.
- 5.1.13. Vehicles that are equipped with an ABS system shall be fitted with a yellow warning lamp. The lamp shall be activated whenever there is a malfunction that affects the generation or transmission of signals in the vehicle's ABS system.
- To permit function checking, the warning lamp shall be illuminated by the activation of the ignition switch and extinguished when the check has been completed.
- The warning lamp shall remain on while a failure condition exists whenever the ignition switch is in the "on" position.
- 5.1.14. The effectiveness of the braking systems, including the anti-lock system, shall not be adversely affected by magnetic or electrical fields. This shall be

demonstrated by fulfilling the technical requirements and respecting the transitional provisions of UN Regulation No. 10 (EMC) by applying:

- (a) The 03 series of amendments for vehicles without a coupling system for charging the Rechargeable Electric Energy Storage System (traction batteries);
- (b) The 04 series of amendments for vehicles with a coupling system for charging the Rechargeable Electric Energy Storage System (traction batteries).

5.1.15. When a vehicle is equipped with the means to indicate emergency braking, activation and de-activation of the emergency braking signal shall only be generated by the application of the service braking system when the following conditions are fulfilled:<sup>3</sup>

5.1.15.1. The signal shall not be activated when the vehicle deceleration is below  $6 \text{ m/s}^2$  but it may be generated at any deceleration at or above this value, the actual value being defined by the vehicle manufacturer.

The signal shall be de-activated at the latest when the deceleration has fallen below  $2.5 \text{ m/s}^2$ .

5.1.15.2. The following conditions may also be used:

(a) The signal may be generated from a prediction of the vehicle deceleration resulting from the braking demand respecting the activation and de-activation thresholds defined in paragraph 5.1.15.1. above;

or

(b) The signal may be activated at a speed above 50 km/h when the antilock system is fully cycling (as defined in paragraph 9.1. of Annex 3) and deceleration is at least  $2.5 \text{ m/s}^2$ . The deceleration may be generated from the prediction described in point (a). The signal shall be deactivated when the antilock system is no longer fully cycling.

5.1.16. A means to deactivate the antilock brake system is not permitted.

By derogation, vehicles which are suitable for off road driving and fitted with a riding mode selector allowing an "off-road" or "all terrain" mode may be fitted with a single means (e.g. switch, lever, button, menu option) to disable the antilock brake system function, which is only permitted under the following conditions:

- (a) The vehicle is stationary; and
- (b) The disablement of the antilock brake system function shall be the result of a deliberate action by the rider according to one of the following methods:
  - (i) Simultaneous actuation of the antilock brake system on/off switch and the front, rear or combined brake system actuator (brake lever or pedal); or

---

<sup>3</sup> At the time of type approval, compliance with this requirement shall be confirmed by the vehicle manufacturer."

- (ii) The actuation of the antilock brake system on/off switch for a minimum of two seconds; or
- (iii) The progression through at least two successive steps or levels of actuation of a rotating knob, a touch panel switch or a menu option selector;
- (c) Disabling of the antilock brake system function shall only be allowed when the riding mode selector is in the "off-road" or "all terrain" mode; and
- (d) The antilock brake system function shall be automatically activated after each start-up of the vehicle, except for restarts after unintentional stalling of the engine; and
- (e) The disablement of the antilock brake system function shall be indicated by the activation of symbol B.18 as specified in ISO 2575:2010 (ISO 7000-2623) or any other equivalent unequivocal indication of the disabled antilock brake system state. Alternatively, the warning lamp referred to in paragraph 5.1.13. shall be continuously activated (i.e. lit or flashing); and
- (f) Prohibition of any software and/or hardware defeat device compromising or allowing to circumnavigate one or more of the requirements set out in points (a) to (e); and
- (g) Instantaneous re-enablement of a functional stage which complies with anti-lock brake system approval requirements of the antilock brake system under all operation modes shall be warranted and shall be demonstrated to the satisfaction of the Type Approval Authority (e.g. simple press of a button).

5.2. Durability

5.2.1. Wear of the brakes shall be compensated for by means of a system of automatic or manual adjustment.

5.2.2. The friction material thickness shall either be visible without disassembly, or where the friction material is not visible, wear shall be assessed by means of a device designed for that purpose.

5.2.3. During all the tests in this Regulation and on their completion, there shall be no friction material detachment and no leakage of brake fluid.

5.3. Measurement of dynamic performance

The method used to measure performance is as specified in the respective tests in Annex 3. There are three ways in which the service brake system performance may be measured:

5.3.1. MFDD (Mean Fully Developed Deceleration):

Calculation of MFDD:

$$d_m = \frac{V_b^2 - V_e^2}{25.92 \cdot (S_e - S_b)} \quad \text{in m/s}^2$$

where:

$d_m$  = mean fully developed deceleration

$V_1$  = vehicle speed when rider actuates the control

$V_b$  = vehicle speed at 0.8  $V_1$  in km/h

$V_e$  = vehicle speed at 0.1  $V_1$  in km/h

$S_b$  = distance travelled between  $V_1$  and  $V_b$  in metres

$S_e$  = distance travelled between  $V_1$  and  $V_e$  in metres

5.3.2. Stopping distance:

Based on the basic equations of motion:

$$S = 0.1 \cdot V + (X) \cdot V^2$$

where:

$S$  = stopping distance in metres

$V$  = vehicle speed in km/h

$X$  = a variable based on the requirement for each test

To calculate the corrected stopping distance using the actual vehicle test speed, the following formula is used:

$$S_s = 0.1 \cdot V_s + (S_a - 0.1 \cdot V_a) \cdot V_s^2 / V_a^2$$

where:

$S_s$  = corrected stopping distance in metres

$V_s$  = specified vehicle test speed in km/h

$S_a$  = actual stopping distance in metres

$V_a$  = actual vehicle test speed in km/h

*Note:* This equation is only valid when the actual test speed ( $V_a$ ) is within  $\pm 5$  km/h of the specified test speed ( $V_s$ ).

5.3.3. Continuous deceleration recording:

For the burnishing procedure and tests such as the wet brake and heat fade – heating procedure, there is a continuous recording of the vehicle's instantaneous deceleration from the moment a force is applied to the brake control until the end of the stop.

5.4. Brake lining materials:

Brake linings shall not contain asbestos.

## 6. Tests

The braking tests (test conditions and procedures) which vehicles submitted for approval are required to undergo, and the braking performance required, are prescribed in Annex 3 to this Regulation.

## **7. Modifications of vehicle type or braking system and extension of approval**

- 7.1. Every modification of the vehicle type or of its braking system shall be communicated to the Type Approval Authority which approved the vehicle type. That Authority may then either:
  - 7.1.1. Consider that the modifications made are unlikely to have an appreciable adverse effect and that in any case the vehicle still complies with the requirements; or
  - 7.1.2. Require a further test report from the Technical Service responsible for conducting the tests.
- 7.2. Confirmation or refusal of approval, specifying the alterations, shall be communicated, by the procedure specified in paragraph 4.3., to the Parties to the Agreement which apply this Regulation.
- 7.3. The Type Approval Authority issuing the extension of approval shall assign a series number to each communication form drawn up for such an extension.

## **8. Conformity of production**

- 8.1. Every vehicle (system) approved to this Regulation shall be so manufactured as to conform to the type approved by meeting the requirements set forth in paragraph 5.
- 8.2. In order to verify that the requirements of paragraph 8.1. are met, suitable controls of the production shall be carried out.
- 8.3. The holder of the approval shall in particular:
  - 8.3.1. Ensure existence of procedures for the effective control of the quality of products;
  - 8.3.2. Have access to the control equipment necessary for checking the conformity to each approved type;
  - 8.3.3. Ensure that data of test results are recorded and that annexed documents shall remain available for a period to be determined in accordance with the Type Approval Authority;
  - 8.3.4. Analyse the results of each type of test, in order to verify and ensure the stability of the product characteristics making allowance for variation of industrial production;
  - 8.3.5. Ensure that for each type of product at least the tests prescribed in Annex 3 to this Regulation are carried out;
  - 8.3.6. Ensure that any sampling of samples or test pieces giving evidence of non-conformity with the type of test considered shall give rise to another sampling and another test. All the necessary steps shall be taken to re-establish the conformity of the corresponding production.
- 8.4. The Type Approval Authority which has granted type approval may at any time verify the conformity control methods applicable to each production unit.

- 8.4.1. In every inspection, the test books and production survey records shall be presented to the visiting inspector.
- 8.4.2. The inspector may take samples at random which will be tested in the manufacturer's laboratory. The minimum number of samples may be determined according to the results of the manufacturer's own verification.
- 8.4.3. When the quality level appears unsatisfactory or when it seems necessary to verify the validity of the tests carried out in application of paragraph 8.4.2., the inspector shall select samples to be sent to the Technical Service which has conducted the type-approval tests.
- 8.4.4. The Type Approval Authority may carry out any test prescribed in this Regulation.
- 8.4.5. The normal frequency of inspections authorized by the Type Approval Authority shall be once every two years. In the case where negative results are recorded during one of these visits, the Type Approval Authority shall ensure that all necessary steps are taken to re-establish the conformity of production as rapidly as possible.

## **9. Transitional provisions**

- 9.1. As from the official date of entry into force of the 04 series of amendments to this Regulation, no Contracting Party applying this Regulation shall refuse to grant or refuse to accept UN type approvals under this Regulation as amended by the 04 series of amendments.
- 9.2. As from 1 September 2018, Contracting Parties applying this Regulation shall grant approvals only if the type of vehicle corresponds to the requirements of this Regulation as amended by the 04 series of amendments.
- 9.3. As from 1 September 2021, Contracting Parties applying this Regulation shall not be obliged to accept, for the purpose of national or regional type approval, a vehicle type approved to the preceding series of amendments to this Regulation.
- 9.4. Notwithstanding the transitional provisions above, Contracting Parties whose application of this Regulation comes into force after the date of entry into force of the most recent series of amendments are not obliged to accept UN type approvals which were granted in accordance with any of the preceding series of amendments to this Regulation.

## **10. Penalties for non-conformity of production**

- 10.1. The approval granted in respect of a vehicle type pursuant to this Regulation may be withdrawn if the requirements laid down in paragraph 8.1. are not complied with or if a vehicle of this type has failed to pass the checks prescribed in paragraph 8.3.
- 10.2. If a Contracting Party to the Agreement which applies this Regulation withdraws an approval it has previously granted, it shall forthwith so notify the other Contracting Parties applying this Regulation, by means of a copy of the approval form bearing at the end, in large letters, the signed and dated annotation "APPROVAL WITHDRAWN".

**11. Production definitively discontinued**

If the holder of the approval completely ceases to manufacture a type of vehicle approved in accordance with this Regulation, he shall so inform the Type Approval Authority which granted the approval. Upon receiving the relevant communication, that Type Approval Authority shall inform thereof the other Parties to the Agreement applying this Regulation by means of a copy of the approval form bearing at the end, in large letters, the signed and dated annotation "PRODUCTION DISCONTINUED".

**12. Names and addresses of Technical Services responsible for conducting approval tests and of Type Approval Authorities**

The Contracting Parties to the Agreement applying this Regulation shall communicate to the United Nations Secretariat the names and addresses of the Technical Services responsible for conducting approval tests and of Type Approval Authorities which grant approval and to which forms certifying approval or extension or refusal or withdrawal of approval, issued in other countries, are to be sent.

## Annex 1\*

### Communication

(Maximum format: A4 (210 x 297 mm))



issued by: Name of administration:  
 .....  
 .....  
 .....

Concerning:<sup>2</sup> Approval granted  
 Approval extended  
 Approval refused  
 Approval withdrawn  
 Production definitively discontinued

of a type of vehicle of category L with regard to braking pursuant to UN Regulation No. 78

Approval No. .... Extension No. ....

1. Trade name or mark of the vehicle .....
2. Vehicle type designation by the manufacturer .....
3. Name and address of the manufacturer: .....
4. Name and address of the manufacturer's representative  
 (if applicable): .....
5. Summarized description: .....
- 5.1. Vehicle:  
 Category of vehicle: .....  
 Gross vehicle mass of vehicle: .....
- 5.2. Engine: .....
- 5.3. Transmission:  
 Number and ratios of gears: .....  
 Final drive ratio: .....

---

\* At the request of (an) applicant(s) for UN Regulation No. 90 approval, the information shall be provided by the Type Approval Authority, as contained in Appendix 1 to this annex. However, this information shall not be provided for purposes other than UN Regulation No. 90 approvals.

<sup>1</sup> Distinguishing number of the country which has granted/extended/refused/withdrawn approval (see approval provisions in the Regulation).

<sup>2</sup> Strike out what does not apply.



- Tyre dimensions: .....
- 5.4. Braking system: .....
- Make(s) and type(s) of linings: .....
- Service brake(s) (front, rear, combined)<sup>2</sup>
- Secondary braking, parking brake (if applicable)<sup>2</sup>
- Other systems (anti-lock brakes, etc.)
6. Technical Service conducting approval tests: .....
7. Date of test report: .....
8. Number of test report: .....
9. Reason for extension of approval (if applicable): .....
10. Other remarks (if applicable), (right or left hand driven): .....
11. Place: .....
12. Date: .....
13. Signature: .....
14. Annexed the list of parts constituting the approval documents, which can be obtained on request, submitted to the Type Approval Authority which has delivered the approval.

## Annex 1 – Appendix

### List of vehicle data for the purpose of UN Regulation No. 90 approvals

1. Description of the vehicle type: .....
- 1.1. Trade name or mark of the vehicle, if available: .....
- 1.2. Vehicle category: .....
- 1.3. Vehicle type according to UN Regulation No. 78 approval: .....
- 1.4. Models or trade names of vehicles constituting the vehicle type, if available: .....
- 1.5. Manufacturer's name and address: .....
2. Make and type of brake linings: .....
3. Minimum mass of vehicle: .....
- 3.1. Distribution of mass of each axle (maximum value): .....
4. Gross vehicle mass of vehicle: .....
- 4.1. Distribution of mass of each axle (maximum value): .....
5. Vmax ..... km/h
6. Tyre and wheel dimensions: .....
7. Configuration of the independent braking systems: .....
8. Specifications of brake valves (if applicable): .....
- 8.1. Adjustment specifications of the load sensing valve: .....
- 8.2. Setting of pressure valve: .....
9. Specification of brake: .....
- 9.1. Disc brake type (e.g. number of pistons with diameter(s), ventilated or solid disc): ...
- 9.2. Drum brake type (e.g. simplex, with piston size and drum dimensions): .....
10. Master cylinder type and size (if applicable): .....

## Annex 2

### Arrangements of approval marks

Model A  
(See paragraph 4.4. of this Regulation)

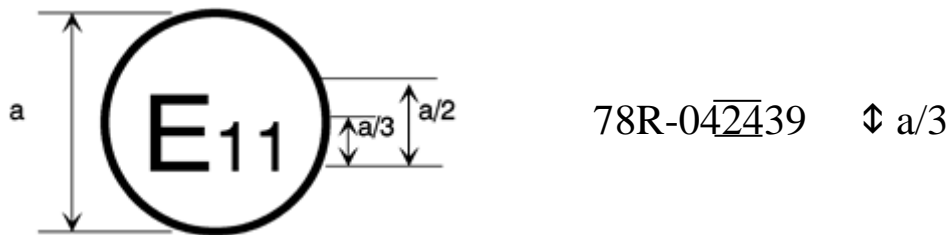

a = 8 mm min.

The above approval mark affixed to a vehicle shows that the vehicle type concerned has, with regard to braking, been approved in the United Kingdom (E 11) pursuant to UN Regulation No. 78 under approval number 042439. The first two digits of the approval number indicate that UN Regulation No. 78 already included the 04 series of amendments when the approval was granted.

Model B  
(See paragraph 4.5. of this Regulation)

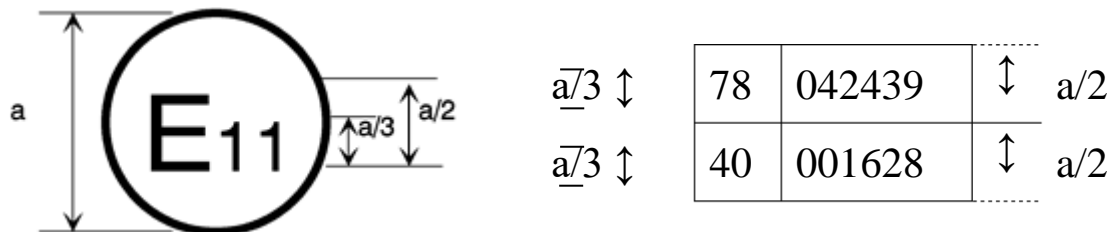

a = 8 mm min.

The above approval mark affixed to a vehicle shows that the vehicle type concerned has been approved in the United Kingdom (E 11) pursuant to UN Regulations Nos. 78 and 40.<sup>1</sup> The first two digits of the approval numbers indicate that, at the dates when the respective approvals were granted, UN Regulation No. 78 included the 04 series of amendments but UN Regulation No. 40 was still in its original form.

<sup>1</sup> This latter number is given merely as an example.

## Annex 3

### Test conditions, procedures and performance requirements

1. General
- 1.1. Test surfaces
  - 1.1.1. High friction surface:
    - (a) Applicable to all dynamic brake tests excluding the ABS tests where a low-friction surface is specified;
    - (b) The test area is a clean and level surface, with a gradient  $\leq 1$  per cent;
    - (c) The surface has a nominal peak braking coefficient (PBC) of 0.9, unless otherwise specified.
  - 1.1.2. Low friction surface:
    - (a) Applicable to all dynamic brake tests where a low-friction surface is specified;
    - (b) The test area is a clean and level surface, with a gradient  $\leq 1$  per cent;
    - (c) The surface has a PBC of  $\leq 0.45$ .
  - 1.1.3. Measurement of PBC:

The PBC is measured as determined by the approval Type Approval Authority using either:

    - (a) An ASTM International (ASTM) E1136-93 (Re-approved 2003) standard reference test tyre, in accordance with ASTM Method E1337-90 (Re-approved 2008), at a speed of 40 mph; or
    - (b) The method specified in the Appendix 1 to this annex:
  - 1.1.4. Parking brake system tests:

The specified test slope shall have a test surface gradient of 18 per cent and shall have a clean and dry surface that does not deform under the mass of the vehicle.
  - 1.1.5. Test lane width:

For two-wheeled vehicles (vehicle categories L<sub>1</sub> and L<sub>3</sub>) the test lane width is 2.5 m.

For three-wheeled and four-wheeled vehicles (vehicle categories L<sub>2</sub>, L<sub>4</sub>, L<sub>5</sub>, L<sub>6</sub> and L<sub>7</sub>) the test lane width is 2.5 m plus the vehicle width.
- 1.2. Ambient temperature

The ambient temperature is between 4 °C and 45 °C.
- 1.3. Wind speed

The wind speed is not more than 5 m/s.
- 1.4. Test speed tolerance

The test speed tolerance is  $\pm 5$  km/h.

In the event of the actual test speed deviating from the specified test speed, the actual stopping distance is corrected using the formula in paragraph 5.3.2. of this Regulation.

1.5. Automatic transmission

Vehicles with automatic transmission shall complete all tests - whether they are for "engine connected" or "engine disconnected".

If an automatic transmission has a neutral position, the neutral position is selected for tests where "engine disconnected" is specified.

1.6. Vehicle position and wheel lock:

- (a) The vehicle is positioned in the centre of the test lane for the beginning of each stop;
- (b) Stops are made without the vehicle wheels passing outside the applicable test lane and without wheel lock.

1.7. Test sequence

Table 1

<i>Test order</i>	<i>Paragraph</i>
1. Dry stop - single brake control actuated	3.
2. Dry stop - all service brake controls actuated	4.
3. High speed	5.
4. Wet brake	6.
5. Heat fade *	7.
6. If fitted:	
6.1. Parking brake system	8.
6.2. ABS	9.
6.3. Partial failure, for split service brake systems	10.
6.4. Power-assisted braking system failure	11.

\* *Note:* Heat fade is always the last test to be carried out.

2. Preparation

2.1. Engine idle speed

The engine idle speed is set to the manufacturer's specification.

2.2. Tyre pressures

The tyres are inflated to the manufacturer's specification for the vehicle loading condition for the test.

2.3. Control application points and direction

For a hand control lever, the input force (F) is applied on the control lever's forward surface perpendicular to the axis of the lever fulcrum and its outermost point on the plane along which the control lever rotates (see Figure 1 below).

The input force is applied to a point located 50 mm from the outermost point of the control lever, measured along the axis between the central axis of the fulcrum of the lever and its outermost point.

Figure 1

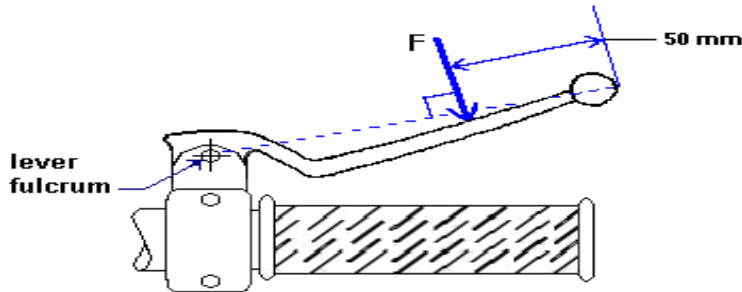

For a foot control pedal, the input force is applied to the centre of, and at right angles to, the control pedal.

2.4. Brake temperature measurement

As determined by the Type Approval Authority, the brake temperature is measured on the approximate centre of the braking path of the disc or drum using:

- (a) A rubbing thermocouple that is in contact with the surface of the disc or drum; or
- (b) A thermocouple that is embedded in the friction material.

2.5. Burnishing procedure

The vehicle brakes are burnished prior to evaluating performance. This procedure may be completed by the manufacturer:

- (a) Vehicle lightly loaded;
- (b) Engine disconnected;
- (c) Test speed:
  - (i) Initial speed: 50 km/h or 0.8  $V_{max}$ , whichever is lower;
  - (ii) Final speed = 5 to 10 km/h;
- (d) Brake application:
  - (i) Each service brake system control actuated separately;
- (e) Vehicle deceleration:
  - (i) Single front brake system only:
    - 3.0-3.5  $m/s^2$  for vehicle categories  $L_3$  and  $L_4$ ;
    - 1.5-2.0  $m/s^2$  for vehicle categories  $L_1$  and  $L_2$ ;
  - (ii) Single rear brake system only: 1.5-2.0  $m/s^2$ ;
  - (iii) CBS or split service brake system: 3.5-4.0  $m/s^2$ ;

- (f) Number of decelerations: 100 per brake system;
  - (g) Initial brake temperature before each brake application  $\leq 100$  °C;
  - (h) For the first stop, accelerate the vehicle to the initial speed and then actuate the brake control under the conditions specified until the final speed is reached. Then reaccelerate to the initial speed and maintain that speed until the brake temperature falls to the specified initial value. When these conditions are met, reapply the brake as specified. Repeat this procedure for the number of specified decelerations. After burnishing, adjust the brakes in accordance with the manufacturer's recommendations.
3. Dry stop test - single brake control actuated
- 3.1. Vehicle condition:
- (a) The test is applicable to all vehicle categories;
  - (b) Laden:  
For vehicles fitted with CBS and split service brake systems: the vehicle is tested in the lightly loaded condition in addition to the laden condition;
  - (c) Engine disconnected.
- 3.2. Test conditions and procedure:
- (a) Initial brake temperature:  $\geq 55$  °C and  $\leq 100$  °C;
  - (b) Test speed:
    - (i) Vehicle categories L<sub>1</sub>, L<sub>2</sub> and L<sub>6</sub> : 40 km/h or 0.9 V<sub>max</sub>, whichever is lower;
    - (ii) Vehicle categories L<sub>3</sub>, L<sub>4</sub>, L<sub>5</sub> and L<sub>7</sub>: 60 km/h or 0.9 V<sub>max</sub>, whichever is lower;
  - (c) Brake application:
    - (i) Each service brake system control actuated separately;
  - (d) Brake actuation force:
    - (i) Hand control:  $\leq 200$  N;
    - (ii) Foot control:  $\leq 350$  N for vehicle categories L<sub>1</sub>, L<sub>2</sub>, L<sub>3</sub>, L<sub>4</sub> and L<sub>6</sub>;  
 $\leq 500$  N for vehicle category L<sub>5</sub> and L<sub>7</sub>;  
 $\leq 500$  N for vehicle category L<sub>5</sub>;
  - (e) Number of stops: until the vehicle meets the performance requirements, with a maximum of 6 stops;
  - (f) For each stop, accelerate the vehicle to the test speed and then actuate the brake control under the conditions specified in this paragraph.
- 3.3. Performance requirements
- When the brakes are tested in accordance with the test procedure set out in paragraph 3.2., the stopping distance shall be as specified in column 2 or the MFDD shall be as specified in Column 3 of the following table:

Table 2

Column 1	Column 2	Column 3
Vehicle Category	STOPPING DISTANCE(S) (Where V is the specified test speed in km/h and S is the required stopping distance in metres)	MFDD
Single brake system, front wheel(s) braking only:		
L <sub>1</sub>	$S \leq 0.1 V + 0.0111 V^2$	$\geq 3.4 \text{ m/s}^2$
L <sub>2</sub> and L <sub>6</sub>	$S \leq 0.1 V + 0.0143 V^2$	$\geq 2.7 \text{ m/s}^2$
L <sub>3</sub>	$S \leq 0.1 V + 0.0087 V^2$	$\geq 4.4 \text{ m/s}^2$
L <sub>5</sub> and L <sub>7</sub>	Not applicable	Not applicable
L <sub>4</sub>	$S \leq 0.1 V + 0.0105 V^2$	$\geq 3.6 \text{ m/s}^2$
Single brake system, rear wheel(s) braking only:		
L <sub>1</sub>	$S \leq 0.1 V + 0.0143 V^2$	$\geq 2.7 \text{ m/s}^2$
L <sub>2</sub> and L <sub>6</sub>	$S \leq 0.1 V + 0.0143 V^2$	$\geq 2.7 \text{ m/s}^2$
L <sub>3</sub>	$S \leq 0.1 V + 0.0133 V^2$	$\geq 2.9 \text{ m/s}^2$
L <sub>5</sub> and L <sub>7</sub>	Not applicable	Not applicable
L <sub>4</sub>	$S \leq 0.1 V + 0.0105 V^2$	$\geq 3.6 \text{ m/s}^2$
Vehicles with CBS or split service brake systems: for laden and lightly loaded conditions:		
L <sub>1</sub> , L <sub>2</sub> and L <sub>6</sub>	$S \leq 0.1 V + 0.0087 V^2$	$\geq 4.4 \text{ m/s}^2$
L <sub>3</sub>	$S \leq 0.1 V + 0.0076 V^2$	$\geq 5.1 \text{ m/s}^2$
L <sub>5</sub> and L <sub>7</sub>	$S \leq 0.1 V + 0.0077 V^2$	$\geq 5.0 \text{ m/s}^2$
L <sub>4</sub>	$S \leq 0.1 V + 0.0071 V^2$	$\geq 5.4 \text{ m/s}^2$
Vehicles with CBS – secondary service brake systems:		
ALL	$S \leq 0.1 V + 0.0154 V^2$	$\geq 2.5 \text{ m/s}^2$

4. Dry stop test – all service brake controls actuated
  - 4.1. Vehicle condition:
    - (a) The test is applicable to vehicle categories L<sub>3</sub>, L<sub>4</sub>, L<sub>5</sub> and L<sub>7</sub>;
    - (b) Lightly loaded;
    - (c) Engine disconnected.
  - 4.2. Test conditions and procedure:



- (a) Initial brake temperature:  $\geq 55\text{ }^{\circ}\text{C}$  and  $\leq 100\text{ }^{\circ}\text{C}$ ;
  - (b) Test speed: 100 km/h or 0.9  $V_{\text{max}}$ , whichever is lower;
  - (c) Brake application:  
Simultaneous actuation of both brake controls, in the case of a vehicle with two service brake systems or actuation of the single brake control in the case of a vehicle with one service brake system.
  - (d) Brake actuation force:  
Hand control:  $\leq 250\text{ N}$ ;  
Foot control:  $\leq 400\text{ N}$  for vehicle categories  $L_3$  and  $L_4$ ;  
 $\leq 500\text{ N}$  for vehicle category  $L_5$  and  $L_7$ ;
  - (e) Number of stops: until the vehicle meets the performance requirements, with a maximum of 6 stops;
  - (f) For each stop, accelerate the vehicle to the test speed and then actuate the brake controls under the conditions specified in this paragraph.
- 4.3. Performance requirements
- When the brakes are tested in accordance with the test procedure set out in paragraph 4.2., the stopping distance (S) shall be  $S \leq 0.0060 V^2$  (where V is the specified test speed in km/h and S is the required stopping distance in metres).
5. High speed test
- 5.1. Vehicle condition:
- (a) The test is applicable to vehicle categories  $L_3$ ,  $L_4$ ,  $L_5$  and  $L_7$ ;
  - (b) Test is not required for vehicles with  $V_{\text{max}} \leq 125\text{ km/h}$ ;
  - (c) Lightly loaded;
  - (d) Engine connected with the transmission in the highest gear.
- 5.2. Test conditions and procedure:
- (a) Initial brake temperature:  $\geq 55\text{ }^{\circ}\text{C}$  and  $\leq 100\text{ }^{\circ}\text{C}$ ;
  - (b) Test speed: 0.8  $V_{\text{max}}$  for vehicles with  $V_{\text{max}} > 125\text{ km/h}$  and  $< 200\text{ km/h}$ ;  
160 km/h for vehicles with  $V_{\text{max}} \geq 200\text{ km/h}$ ;
  - (c) Brake application:  
Simultaneous actuation of both brake controls, in the case of a vehicle with two service brake systems or actuation of the single brake control in the case of a vehicle with one service brake system.
  - (d) Brake actuation force:  
Hand control:  $\leq 200\text{ N}$ ;  
Foot control:  $\leq 350\text{ N}$  for vehicle categories  $L_3$  and  $L_4$ ;  
 $\leq 500\text{ N}$  for vehicle category  $L_5$  and  $L_7$ ;

- (e) Number of stops: until the vehicle meets the performance requirements, with a maximum of 6 stops;
  - (f) For each stop, accelerate the vehicle to the test speed and then actuate the brake control(s) under the conditions specified in this paragraph.
- 5.3. Performance requirements:

When the brakes are tested in accordance with the test procedure set out in paragraph 5.2.:

  - (a) The stopping distance (S) shall be  $\leq 0.1 V + 0.0067 V^2$   
(where V is the specified test speed in km/h and S is the required stopping distance in metres); or
  - (b) The MFDD shall be  $\geq 5.8 \text{ m/s}^2$ .
- 6. Wet brake test
- 6.1. General:
  - (a) The test is comprised of two parts that are carried out consecutively for each brake system:
    - (i) A baseline test based on the dry stop test - single brake control actuated (section 3. of this annex);
    - (ii) A single wet brake stop using the same test parameters as in (i), but with the brake(s) being continuously sprayed with water while the test is conducted in order to measure the brakes' performance in wet conditions;
  - (b) The test is not applicable to a parking brake system, unless it is the secondary brake;
  - (c) Drum brakes or fully enclosed disc brakes are exempt from this test unless ventilation or open inspection ports are present;
  - (d) This test requires the vehicle to be fitted with instrumentation that gives a continuous recording of brake control force and vehicle deceleration. The MFDD and the stopping distance measurements are not appropriate in this case.
- 6.2. Vehicle condition:
  - (a) The test is applicable to all vehicle categories;
  - (b) Laden:

For vehicles fitted with CBS and split service brake systems: the vehicle is tested in the lightly loaded condition in addition to the laden condition;
  - (c) Engine disconnected;
  - (d) Each brake is fitted with water spray equipment:
    - (i) Disc brakes: Sketch of water spray equipment:

Figure 2

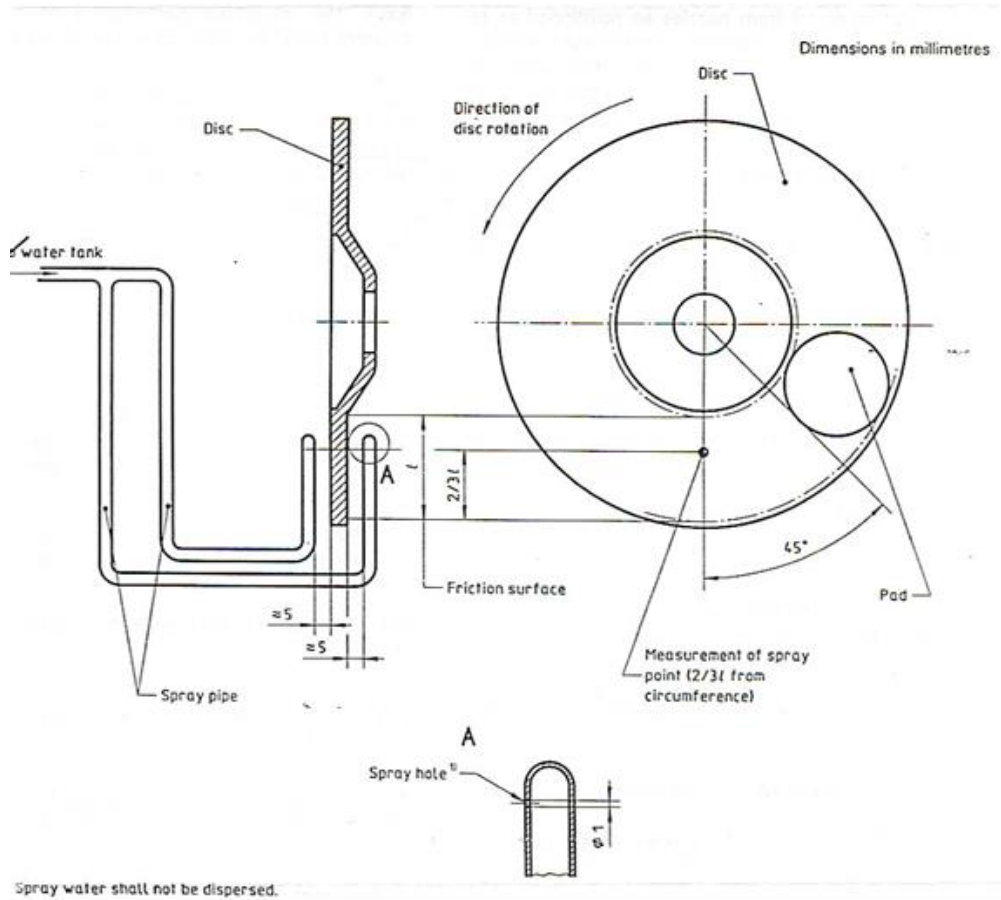

The disc brake water spray equipment is installed as follows:

- a. Water is sprayed onto each brake with a flow rate of 15 litres/hr. The water is equally distributed on each side of the rotor;
- b. If the surface of the rotor has any shielding, the spray is applied 45° prior to the shield;
- c. If it is not possible to locate the spray in the position shown on the sketch, or if the spray coincides with a brake ventilation hole or similar, the spray nozzle may be advanced by an additional 90° maximum from the edge of the pad, using the same radius;

- (ii) Drum brakes with ventilation and open inspection ports:

The water spray equipment is installed as follows:

- a. Water is sprayed equally onto both sides of the drum brake assembly (on the stationary back plate and on the rotating drum) with a flow rate of 15 litres/hr;

- b. The spray nozzles are positioned two thirds of the distance from the outer circumference of the rotating drum to the wheel hub centre;
    - c. The nozzle position is  $> 15^\circ$  from the edge of any opening in the drum back plate.
- 6.3. Baseline test
- 6.3.1. Test conditions and procedure:
  - (a) The test in section 3. of this annex (dry stop test - single brake control actuated) is carried out for each brake system but with the brake control force that results in a vehicle deceleration of  $2.5 - 3.0 \text{ m/s}^2$ , and the following is determined:
    - (i) The average brake control force measured when the vehicle is travelling between 80 per cent and 10 per cent of the specified test speed;
    - (ii) The average vehicle deceleration in the period 0.5 to 1.0 seconds after the point of actuation of the brake control;
    - (iii) The maximum vehicle deceleration during the complete stop but excluding the final 0.5 seconds;
  - (b) Conduct 3 baseline stops and average the values obtained in (i), (ii), and (iii).
- 6.4. Wet brake stop
- 6.4.1. Test conditions and procedure:
  - (a) The vehicle is ridden at the test speed used in the baseline test set out in paragraph 6.3. with the water spray equipment operating on the brake(s) to be tested and with no application of the brake system;
  - (b) After a distance of  $\geq 500 \text{ m}$ , apply the averaged brake control force determined in the baseline test for the brake system being tested;
  - (c) Measure the average vehicle deceleration in the period 0.5 to 1.0 seconds after the point of actuation of the brake control;
  - (d) Measure the maximum vehicle deceleration during the complete stop but excluding the final 0.5 seconds.
- 6.5. Performance requirements

When the brakes are tested in accordance with the test procedure set out in paragraph 6.4.1., the wet brake deceleration performance shall be:

  - (a) The value measured in paragraph 6.4.1.(c)  $\geq 60$  per cent of the averaged deceleration values recorded in the baseline test in paragraph 6.3.1.(a)(ii), i.e. in the period 0.5 to 1.0 seconds after the point of application of the brake control; and
  - (b) The value measured in 6.4.1.(d)  $\leq 120$  per cent of the averaged deceleration values recorded in the baseline test 6.3.1.(a)(iii), i.e. during the complete stop but excluding the final 0.5 seconds.

7. Heat fade test
- 7.1. General:
- (a) The test comprises three parts that are carried out consecutively for each brake system:
    - (i) A baseline test using the dry stop test - single brake control actuated (section 3. of this annex);
    - (ii) A heating procedure which consists of a series of repeated stops in order to heat the brake(s);
    - (iii) A hot brake stop using the dry stop test - single brake control actuated (section 3 of this annex), to measure the brake's performance after the heating procedure;
  - (b) The test is applicable to vehicle categories L<sub>3</sub>, L<sub>4</sub>, L<sub>5</sub> and L<sub>7</sub>;
  - (c) The test is not applicable to parking brake systems and secondary service brake systems;
  - (d) All stops are carried out with the vehicle laden;
  - (e) The heating procedure requires the vehicle to be fitted with instrumentation that gives a continuous recording of brake control force and vehicle deceleration. The MFDD and stopping distance measurements are not appropriate for the heating procedure. The baseline test and the hot brake stop require the measurement of either MFDD or the stopping distance.
- 7.2. Baseline test
- 7.2.1. Vehicle condition:
- (a) Engine disconnected.
- 7.2.2. Test conditions and procedure:
- (a) Initial brake temperature:  $\geq 55\text{ }^{\circ}\text{C}$  and  $\leq 100\text{ }^{\circ}\text{C}$ ;
  - (b) Test speed: 60 km/h or 0.9 V<sub>max</sub>, whichever is lower;
  - (c) Brake application:  
Each service brake system control actuated separately;
  - (d) Brake actuation force:  
Hand control:  $\leq 200\text{ N}$ ;  
Foot control:  $\leq 350\text{ N}$  for vehicle categories L<sub>3</sub> and L<sub>4</sub>;  
 $\leq 500\text{ N}$  for vehicle category L<sub>5</sub> and L<sub>7</sub>;
  - (e) Accelerate the vehicle to the test speed, actuate the brake control under the conditions specified and record the control force required to achieve the vehicle braking performance specified in the table to paragraph 3.3. of this annex.
- 7.3. Heating procedure
- 7.3.1. Vehicle condition:
- (a) Engine transmission:

- (i) From the specified test speed to 50 per cent specified test speed: connected, with the highest appropriate gear selected such that the engine speed remains above the manufacturer's specified idle speed;
- (ii) From 50 per cent specified test speed to standstill: disconnected.

7.3.2. Test conditions and procedure:

- (a) Initial brake temperature prior to first stop only:  $\geq 55$  °C and  $\leq 100$  °C;
- (b) Test speed:  
Single brake system, front wheel braking only: 100 km/h or 0.7 Vmax, whichever is lower;  
Single brake system, rear wheel braking only: 80 km/h or 0.7 Vmax, whichever is lower;  
CBS or split service brake system: 100 km/h or 0.7 Vmax, whichever is lower;
- (c) Brake application:  
Each service brake system control actuated separately;
- (d) Brake actuation force:
  - (i) For the first stop:  
The constant control force that achieves a vehicle deceleration rate of 3.0 - 3.5 m/s<sup>2</sup> while the vehicle is decelerating between 80 per cent and 10 per cent of the specified speed;  
If the vehicle is unable to achieve the specified vehicle deceleration rate, this stop is carried out to meet the deceleration requirements in the table in paragraph 3.3. of this annex;
  - (ii) For the remaining stops:
    - a. The same constant brake control force as used for the first stop;
    - b. Number of stops: 10;
    - c. Interval between stops: 1000 m;
- (e) Carry out a stop to the conditions specified in this paragraph and then immediately use maximum acceleration to reach the specified speed and maintain that speed until the next stop is made.

7.4. Hot brake stop

7.4.1. Test conditions and procedure:

Perform a single stop under the conditions used in the baseline test (paragraph 7.2.) for the brake system that has been heated during the procedure in accordance with paragraph 7.3. This stop is carried out within one minute of the completion of the procedure set out in paragraph 7.3. with a brake control application force less than or equal to the force used during the test set out in paragraph 7.2.

- 7.5. Performance requirements
- When the brakes are tested in accordance with the test procedure set out in paragraph 7.4.1.:
- (a) The stopping distance:  $S_2 \leq 1.67 S_1 - 0.67 \times 0.1V$   
where:  
 $S_1$  = corrected stopping distance in metres achieved in the baseline test set out in paragraph 7.2.  
 $S_2$  = corrected stopping distance in metres achieved in the hot brake stop set out in paragraph 7.4.1.  
 $V$  = specified test speed in km/h; or
- (b) The MFDD  $\geq$  60 per cent of the MFDD recorded in the test set out in paragraph 7.2.
8. Parking brake system test – for vehicles equipped with parking brakes
- 8.1. Vehicle condition:
- (a) The test is applicable to vehicle categories L<sub>2</sub>, L<sub>4</sub>, L<sub>5</sub> and L<sub>7</sub>;  
(b) Laden;  
(c) Engine disconnected.
- 8.2. Test conditions and procedure:
- (a) Initial brake temperature:  $\leq 100$  °C;  
(b) Test surface gradient = 18 per cent;  
(c) Brake actuation force:  
Hand control:  $\leq 400$  N;  
Foot control:  $\leq 500$  N;  
(d) For the first part of the test, park the vehicle on the test surface gradient facing up the slope by applying the parking brake system under the conditions specified in this paragraph. If the vehicle remains stationary, start the measurement of the test period;  
(e) On completion of the test with vehicle facing up the gradient, repeat the same test procedure with the vehicle facing down the gradient.
- 8.3. Performance requirements:
- When tested in accordance with the test procedure set out in paragraph 8.2., the parking brake system shall hold the vehicle stationary for 5 minutes when the vehicle is both facing up and facing down the gradient.
9. ABS tests
- 9.1. General:
- (a) The tests are only applicable to the ABS if fitted;  
(b) The tests are to confirm the performance of brake systems equipped with ABS and their performance in the event of ABS electrical failure;

- (c) "Fully cycling" means that the anti-lock system is repeatedly or continuously modulating the brake force to prevent the directly controlled wheels from locking;
- (d) Wheel-lock is allowed as long as the stability of the vehicle is not affected to the extent that it requires the operator to release the control or causes a vehicle wheel to pass outside the test lane.

The test series comprises the following individual tests, which may be carried out in any order:

Table 3

<i>ABS Tests</i>	<i>Paragraph</i>
a. Stops on a high friction surface - as specified in paragraph 1.1.1.	9.3.
b. Stops on a low friction surface - as specified in paragraph 1.1.2.	9.4.
c. Wheel lock checks on high and low friction surfaces.	9.5.
d. Wheel lock check - high to low friction surface transition.	9.6.
e. Wheel lock check - low to high friction surface transition.	9.7.
f. Stops with an ABS electrical failure.	9.8.

9.2. Vehicle condition:

- (a) Lightly loaded;
- (b) Engine disconnected.

9.3. Stops on a high friction surface:

9.3.1. Test conditions and procedure:

- (a) Initial brake temperature:  $\geq 55$  °C and  $\leq 100$  °C;
- (b) Test speed: 60 km/h or 0.9 Vmax, whichever is lower;
- (c) Brake application:  
Simultaneous actuation of both brake controls, in the case of a vehicle with two service brake systems or actuation of the single brake control in the case of a vehicle with one service brake system.
- (d) Brake actuation force:  
The force applied is that which is necessary to ensure that the ABS will be fully cycling throughout each stop, down to 10 km/h;
- (e) If one wheel is not equipped with ABS, the control for the service brake on that wheel shall be actuated with a force that is lower than the force that will cause the wheel to lock;
- (f) Number of stops: until the vehicle meets the performance requirements, with a maximum of 6 stops;
- (g) For each stop, accelerate the vehicle to the test speed and then actuate the brake control under the conditions specified in this paragraph.

9.3.2. Performance requirements

When the brakes are tested in accordance with the test procedures referred to in paragraph 9.3.1.:



- (a) The stopping distance (S) shall be  $\leq 0.0063V^2$  (where V is the specified test speed in km/h and S is the required stopping distance in metres) or the MFDD shall be  $\geq 6.17 \text{ m/s}^2$ ; and
  - (b) There shall be no wheel lock and the vehicle wheels shall stay within the test lane.
- 9.4. Stops on a low friction surface:
- 9.4.1. Test conditions and procedure:  
As set out in paragraph 9.3.1., but using the low friction surface instead of the high friction one;
- 9.4.2. Performance requirements  
When the brakes are tested in accordance with the test procedures set out in paragraph 9.4.1.:
- (a) The stopping distance (S) shall be  $\leq 0.0056V^2/P$  (where V is the specified test speed in km/h, P is the peak braking coefficient and S is the required stopping distance in metres) or the MFDD shall be  $\geq 6.87 \times P$ , in  $\text{m/s}^2$ ; and
  - (b) There shall be no wheel lock and the vehicle wheels shall stay within the test lane.
- 9.5. Wheel lock checks on high and low friction surfaces:
- 9.5.1. Test conditions and procedure:
- (a) Test surfaces:
    - (i) High friction; and
    - (ii) Low friction;
  - (b) Initial brake temperature:  $\geq 55 \text{ }^\circ\text{C}$  and  $\leq 100 \text{ }^\circ\text{C}$ ;
  - (c) Test speed:
    - (i) On the high friction surface: 80 km/h or 0.8 V<sub>max</sub>, whichever is lower;
    - (ii) On the low friction surface: 60 km/h or 0.8 V<sub>max</sub>, whichever is lower;
  - (d) Brake application:
    - (i) Each service brake system control actuated separately;
    - (ii) Where ABS is fitted to both brake systems, simultaneous actuation of both brake controls in addition to (i);
  - (e) Brake actuation force:  
The force applied is that which is necessary to ensure that the ABS will be fully cycling throughout each stop, down to 10 km/h;
  - (f) Brake application rate:  
The brake control actuation force is applied in 0.1 – 0.5 seconds;
  - (g) Number of stops: until the vehicle meets the performance requirements, with a maximum of 3 stops;

- (h) For each stop, accelerate the vehicle to the test speed and then actuate the brake control under the conditions specified in this paragraph.
- 9.5.2. Performance requirements:
- When the brakes are tested in accordance with the test procedures set out in paragraph 9.5.1., there shall be no wheel lock and the vehicle wheels shall stay within the test lane.
- 9.6. Wheel lock check - high to low friction surface transition:
- 9.6.1. Test conditions and procedure:
- (a) Test surfaces:

A high friction surface immediately followed by a low friction surface;
  - (b) Initial brake temperature:  $\geq 55\text{ }^{\circ}\text{C}$  and  $\leq 100\text{ }^{\circ}\text{C}$ ;
  - (c) Test speed:

The speed that will result in 50 km/h or 0.5 Vmax, whichever is lower, at the point where the vehicle passes from the high friction to the low friction surface;
  - (d) Brake application:
    - (i) Each service brake system control actuated separately;
    - (ii) Where ABS is fitted to both brake systems, simultaneous actuation of both brake controls in addition to (i);
  - (e) Brake actuation force:

The force applied is that which is necessary to ensure that the ABS will be fully cycling throughout each stop, down to 10 km/h;
  - (f) Number of stops: until the vehicle meets the performance requirements, with a maximum of 3 stops;
  - (g) For each stop, accelerate the vehicle to the test speed and then actuate the brake control before the vehicle reaches the transition from one friction surface to the other.
- 9.6.2. Performance requirements:
- When the brakes are tested in accordance with the test procedures set out in paragraph 9.6.1., there shall be no wheel lock and the vehicle wheels shall stay within the test lane.
- 9.7. Wheel lock check - low to high friction surface transition:
- 9.7.1. Test conditions and procedure:
- (a) Test surfaces:

A low friction surface immediately followed by a high friction surface with a PBC  $\geq 0.8$ ;
  - (b) Initial brake temperature:  $\geq 55\text{ }^{\circ}\text{C}$  and  $\leq 100\text{ }^{\circ}\text{C}$ ;
  - (c) Test speed:

The speed that will result in 50 km/h or 0.5 V<sub>max</sub>, whichever is lower, at the point where the vehicle passes from the low friction to the high friction surface;

- (d) Brake application:
  - (i) Each service brake system control applied separately;
  - (ii) Where ABS is fitted to both brake systems, simultaneous application of both brake controls in addition to (i);
- (e) Brake actuation force:

The force applied is that which is necessary to ensure that the ABS will be fully cycling throughout each stop, down to 10 km/h;
- (f) Number of stops: until the vehicle meets the performance requirements, with a maximum of 3 stops;
- (g) For each stop, accelerate the vehicle to the test speed and then actuate the brake control before the vehicle reaches the transition from one friction surface to the other;
- (h) Record the vehicle's continuous deceleration.

9.7.2. Performance requirements:

- (a) When the brakes are tested in accordance with the test procedures set out in paragraph 9.7.1., there shall be no wheel lock and the vehicle wheels shall stay within the test lane;
- (b) Within 1 second of the rear wheel passing the transition point between the low and high friction surfaces, the vehicle deceleration shall increase.

9.8. Stops with an ABS electrical failure:

9.8.1. Test conditions and procedure:

- (a) With the ABS electrical system disabled, carry out the test set out in section 3. of this annex, (dry stop test – single brake control actuated) applying the conditions relevant to the brake system and vehicle being tested.

9.8.2. Performance requirements:

When the brakes are tested in accordance with the test procedure set out in paragraph 9.8.1.:

- (a) The system shall comply with the failure warning requirements of paragraph 5.1.13. of this Regulation; and
- (b) The minimum requirements for stopping distance or MFDD shall be as specified in column 2 or 3, respectively, under the heading "Single brake system, rear wheel(s) braking only" in the table to paragraph 3.3. of this annex.

10. Partial failure test - for split service brake systems

10.1. General information:

- (a) The test is only applicable to vehicles that are equipped with split service brake systems;

- (b) The test is to confirm the performance of the remaining subsystem in the event of a hydraulic system leakage failure.
- 10.2. Vehicle condition:
  - (a) The test is applicable to vehicle categories L<sub>3</sub>, L<sub>4</sub>, L<sub>5</sub> and L<sub>7</sub>;
  - (b) Lightly loaded;
  - (c) Engine disconnected.
- 10.3. Test conditions and procedure:
  - (a) Initial brake temperature:  $\geq 55\text{ °C}$  and  $\leq 100\text{ °C}$ ;
  - (b) Test speeds: 50 km/h and 100 km/h or 0.8 V<sub>max</sub>, whichever is lower;
  - (c) Brake actuation force:
    - Hand control:  $\leq 250\text{ N}$ ;
    - Foot control:  $\leq 400\text{ N}$ ;
  - (d) Number of stops: until the vehicle meets the performance requirements, with a maximum of 6 stops for each test speed;
  - (e) Alter the service brake system to induce a complete loss of braking in any one subsystem. Then, for each stop, accelerate the vehicle to the test speed and then actuate the brake control under the conditions specified in this paragraph;
  - (f) Repeat the test for each subsystem.
- 10.4. Performance requirements:

When the brakes are tested in accordance with the test procedure set out in paragraph 10.3.:

  - (a) the system shall comply with the failure warning requirements set out in paragraph 5.1.11. of this Regulation; and
  - (b) the stopping distance (S) shall be  $\leq 0.1 V + 0.0117 V^2$  (where V is the specified test speed in km/h and S is the required stopping distance in metres) or the MFDD shall be  $\geq 3.3\text{ m/s}^2$ .
- 11. Power-assisted braking system failure test
- 11.1. General information:
  - (a) The test is not conducted when the vehicle is equipped with another separate service brake system;
  - (b) The test is to confirm the performance of the service brake system in the event of failure of the power assistance.
- 11.2. Test conditions and procedure:
  - (a) Carry out the test set out in section 3. of this annex, (dry stop test – single brake control actuated) for each service brake system with the power assistance disabled.

11.3. Performance requirements

When the brakes are tested in accordance with the test procedure set out in paragraph 11.2., the stopping distance shall be as specified in Column 2 or the MFDD shall be as specified in Column 3 of the following table:

Table 4

Column 1	Column 2	Column 3
Vehicle Category	STOPPING DISTANCE(S) (Where V is the specified test speed in km/h and S is the required stopping distance in metres)	MFDD
Single brake system		
L <sub>1</sub>	$S \leq 0.1 V + 0.0143 V^2$	$\geq 2.7 \text{ m/s}^2$
L <sub>2</sub> and L <sub>6</sub>	$S \leq 0.1 V + 0.0143 V^2$	$\geq 2.7 \text{ m/s}^2$
L <sub>3</sub>	$S \leq 0.1 V + 0.0133 V^2$	$\geq 2.9 \text{ m/s}^2$
L <sub>4</sub>	$S \leq 0.1 V + 0.0105 V^2$	$\geq 3.6 \text{ m/s}^2$
Vehicles with CBS or SSBS		
ALL	$S \leq 0.1 V + 0.0154 V^2$	$\geq 2.5 \text{ m/s}^2$

Note that if the power assistance may be activated by more than one control, the above performance shall be achieved when each control is actuated separately.

12. CBS failure test

12.1. General information:

- (a) This test will only apply to vehicles fitted with CBS of which the separate service brake systems share a common hydraulic or common mechanical transmission;
- (b) The test is to confirm the performance of the service brake systems in the event of a transmission failure. This can be demonstrated by a common hydraulic hose or mechanical cable failure.

12.2. Test conditions and procedure:

- (a) Alter the brake system to produce a failure causing a complete loss of braking in the portion of the system which is shared;
- (b) Perform the dry stop test specified in section 3. in the laden condition. Other conditions to be observed are sections 3.1.(c) and 3.2.(a), (b), (d), (e) and (f). Instead of the provisions in section 3.2.(c), only apply the control for the brake not affected by the simulated failure.

12.3. Performance requirements

When the brakes are tested in accordance with the test procedure set out in paragraph 12.2., the stopping distance shall be as specified in Column 2 or the MFDD shall be as specified in Column 3 of the following table:

Table 5

Column 1	Column 2	Column 3
Vehicle Category	STOPPING DISTANCE (S) (Where V is the specified test speed in km/h and S is the required stopping distance in metres)	MFDD
Front wheel(s) braking only		
L <sub>1</sub>	$S \leq 0.1 V + 0.0111 V^2$	$\geq 3.4 \text{ m/s}^2$
L <sub>2</sub> and L <sub>6</sub>	$S \leq 0.1 V + 0.0143 V^2$	$\geq 2.7 \text{ m/s}^2$
L <sub>3</sub>	$S \leq 0.1 V + 0.0087 V^2$	$\geq 4.4 \text{ m/s}^2$
L <sub>4</sub>	$S \leq 0.1 V + 0.0105 V^2$	$\geq 3.6 \text{ m/s}^2$
L <sub>5</sub> and L <sub>7</sub>	$S \leq 0.1 V + 0.0117 V^2$	$\geq 3.3 \text{ m/s}^2$
Rear wheel(s) braking only		
L <sub>1</sub>	$S \leq 0.1 V + 0.0143 V^2$	$\geq 2.7 \text{ m/s}^2$
L <sub>2</sub> and L <sub>6</sub>	$S \leq 0.1 V + 0.0143 V^2$	$\geq 2.7 \text{ m/s}^2$
L <sub>3</sub>	$S \leq 0.1 V + 0.0133 V^2$	$\geq 2.9 \text{ m/s}^2$
L <sub>4</sub>	$S \leq 0.1 V + 0.0105 V^2$	$\geq 3.6 \text{ m/s}^2$
L <sub>5</sub> and L <sub>7</sub>	$S \leq 0.1 V + 0.0117 V^2$	$\geq 3.3 \text{ m/s}^2$

## Annex 3 - Appendix 1

### Alternative method for the determination of peak braking coefficient (PBC)

(see paragraph 1.1.3. to this annex)

#### 1.1. General:

- (a) The test is to establish a PBC for the vehicle type when being braked on the test surfaces described in Annex 3, paragraphs 1.1.1. and 1.1.2.
- (b) The test comprises a number of stops with varying brake control forces. Both wheels shall be braked simultaneously up to the point reached before wheel lock, in order to achieve the maximum vehicle deceleration rate on the given test surface.
- (c) The maximum vehicle deceleration rate is the highest value recorded during all the test stops.
- (d) The Peak Braking Coefficient (PBC) is calculated from the test stop that generates the maximum vehicle deceleration rate, as follows:

$$PBC = \frac{0.566}{t}$$

where:

t = time taken for the vehicle speed to reduce from 40 km/h to 20 km/h in seconds.

*Note:* For vehicles unable to achieve a test speed of 50 km/h, PBC shall be measured as follows:

$$PBC = \frac{0.566}{t}$$

where:

t = time taken, in seconds, for the speed of the vehicle to reduce from 0.8 V<sub>max</sub> to (0.8 V<sub>max</sub> - 20), where V<sub>max</sub> is measured in km/h.

- (e) The value of PBC shall be rounded to two decimal places.

#### 1.2. Vehicle condition:

- (a) The test is applicable to all vehicle categories.
- (b) The anti-lock system shall be either disconnected or inoperative (ABS function disabled), between 40 km/h and 20 km/h.
- (c) Lightly loaded.
- (d) Engine disconnected.

#### 1.3. Test conditions and procedure:

- (a) Initial brake temperature:  $\geq 55$  °C and  $\leq 100$  °C.

- (b) Test speed: 60 km/h or 0.9 Vmax, whichever is lower.
- (c) Brake application:  

Simultaneous actuation of both service brake system controls, if so equipped, or of the single service brake system control in the case of a service brake system that operates on all wheels.

For vehicles equipped with a single service brake system control, it may be necessary to modify the brake system if one of the wheels is not approaching maximum deceleration.
- (d) Brake actuation force:  

The control force that achieves the maximum vehicle deceleration rate as defined in paragraph 1.1.(c).

The application of the control force shall be constant during braking.
- (e) Number of stops: until the vehicle meets its maximum deceleration rate.
- (f) For each stop, accelerate the vehicle to the test speed and then actuate the brake control(s) under the conditions specified in this paragraph.

---