

24 June 2019

---

## **Agreement**

### **Concerning the Adoption of Harmonized Technical United Nations Regulations for Wheeled Vehicles, Equipment and Parts which can be Fitted and/or be Used on Wheeled Vehicles and the Conditions for Reciprocal Recognition of Approvals Granted on the Basis of these United Nations Regulations\***

(Revision 3, including the amendments which entered into force on 14 September 2017)

---

#### **Addendum 28 – UN Regulation No. 29**

#### **Revision 2 - Amendment 4**

Supplement 4 to the 03 series of amendments – Date of entry into force: 28 May 2019

#### **Uniform provisions concerning the approval of vehicles with regard to the protection of the occupants of the cab of a commercial vehicle**

This document is meant purely as documentation tool. The authentic and legal binding text is: ECE/TRANS/WP.29/2018/130.



**UNITED NATIONS**

---

\* Former titles of the Agreement:

Agreement concerning the Adoption of Uniform Conditions of Approval and Reciprocal Recognition of Approval for Motor Vehicle Equipment and Parts, done at Geneva on 20 March 1958 (original version); Agreement concerning the Adoption of Uniform Technical Prescriptions for Wheeled Vehicles, Equipment and Parts which can be Fitted and/or be Used on Wheeled Vehicles and the Conditions for Reciprocal Recognition of Approvals Granted on the Basis of these Prescriptions, done at Geneva on 5 October 1995 (Revision 2).

*Paragraph 7, amend to read:*

## **"7. Conformity of production**

The conformity of production procedures shall comply with those set out in the Agreement, (Schedule 1, E/ECE/TRANS/505/Rev.3), with the following requirements:"

*Annex 3, Appendix 1, amend to read:*

## **"Annex 3 - Appendix 1**

### **Instructions for securing vehicles to the test bed**

1. General instructions for securing
  - 1.1. Measures shall be taken to ensure that the vehicle does not shift appreciably during the test. For this purpose the hand-brake shall be applied, a gear engaged and the front wheels wedged with chocks.
  - 1.2. Anchoring chains or ropes

Each anchoring chain or rope shall be of steel and shall be capable of withstanding a tractive load of at least 10 tons.
  - 1.3. Blocking of the chassis frame

The longitudinal members of the chassis frame shall be supported on wooden blocks, rigid composite blocks and/or adjustable metal brackets across their full width and over a length of not less than 150 mm. The front edges of the blocks must not be situated forward of the rearmost point of the cab, nor rearward of the mid-point of the wheel base (see Figure 1 below). At the manufacturer's request the chassis frame shall be set in the attitude it takes up when loaded.
  - 1.4. Longitudinal attachment

Rearward movement of the chassis frame shall be limited by chains or ropes A attached to the front of the chassis frame symmetrically in relation to its longitudinal axis, the points of attachment being not less than 600 mm apart. The chains or ropes shall when tensioned form a downward angle of not more than 25° with the horizontal and their projection on a horizontal plane shall form an angle of not more than 10° with the longitudinal axis of the vehicle (see Figure 1 below). The chains or ropes may cross one another.
  - 1.5. Tensioning of chains or ropes and rear attachment

For tests A and B, the chain or rope C shall, to begin with, be placed under a load of approximately 1 kN. All slack in the four chains or ropes A and B shall then be taken up and chain or rope C shall be subjected to a tensile stress of not less than 10 kN. The angle of chain or rope C with the horizontal shall not exceed 15°. A vertical blocking force of not less than 500 N shall be applied at point D between the chassis frame and the ground (see Figure 1 below). For test C, the chains or ropes B as described above shall be replaced by the chains or ropes E and F (see Figure 2 below).

- 1.6. Equivalent mounting

At the request of the manufacturer the test may be carried out with the cab mounted on a special frame, on condition that this method of mounting is shown to be equivalent to mounting on the vehicle.
2. Frontal impact
  - 2.1. Cab mounted on the vehicle

Test A shall be applied to a cab mounted on the vehicle as described in paragraph 1.
  - 2.1.1. Lateral attachment

Lateral movement shall be limited by chains or ropes B attached to the chassis frame symmetrically in relation to its longitudinal axis. The points of attachment to the chassis shall be not more than 5 m and not less than 3 m from the front of the vehicle. The chains or ropes shall when tensioned form a downward angle of not more than 20° with the horizontal and their projection on a horizontal plane shall form an angle of not less than 25° and not more than 45° with the longitudinal axis of the vehicle (see Figure 1 below).
  - 2.2. Cab mounted on a frame

Measures shall be taken to ensure that the cab does not shift appreciably during the test.
3. Front pillars impact
  - 3.1. Cab mounted on the vehicle.

Test B shall be applied to a cab mounted on the vehicle as described in paragraph 1.
  - 3.1.1. Lateral attachment

Lateral movement shall be limited by chains or ropes B attached to the chassis frame symmetrically in relation to its longitudinal axis. The points of attachment to the chassis shall be not more than 5 m and not less than 3 m from the front of the vehicle. The chains or ropes shall when tensioned form a downward angle of not more than 20° with the horizontal and their projection on a horizontal plane shall form an angle of not less than 25° and not more than 45° with the longitudinal axis of the vehicle (see Figure 1 below).
  - 3.2. Cab mounted on a frame

Measures shall be taken to ensure that the cab does not shift appreciably during the test.
4. Roof strength
  - 4.1. Cab mounted on the vehicle

Test C shall be applied to a cab mounted on the vehicle as described in paragraph 1.
  - 4.1.1. Blocking of the chassis frame

Notwithstanding paragraph 1.3. an additional support shall be placed under both sides of the longitudinal members of the chassis frame's front end.

4.1.2. Lateral attachment

Lateral movement shall be limited by chains or ropes E and F attached to the chassis frame symmetrically in relation to its longitudinal axis.

The points of attachment of chains or rope E to the chassis shall be not more than 5 m and not less than 3 m from the front of the vehicle.

The points of attachment of chains or rope F to the chassis shall be between the centre of the front axle and the front of the vehicle.

The chains or ropes shall when tensioned form a downward angle of not more than 20° with the horizontal and their projection on a horizontal plane shall form an angle  $90^{\circ} \pm 5^{\circ}$  with the longitudinal axis of the vehicle (see Figure 2 below).

4.2. Cab mounted on a frame

Measures shall be taken to ensure that the frame does not shift appreciably during the test."

*Figure 1*, shall be deleted

Insert new Figures 1 and 2, to read:

"Figure 1  
Front impact test and front pillars impact test  
The cab is mounted on the vehicle

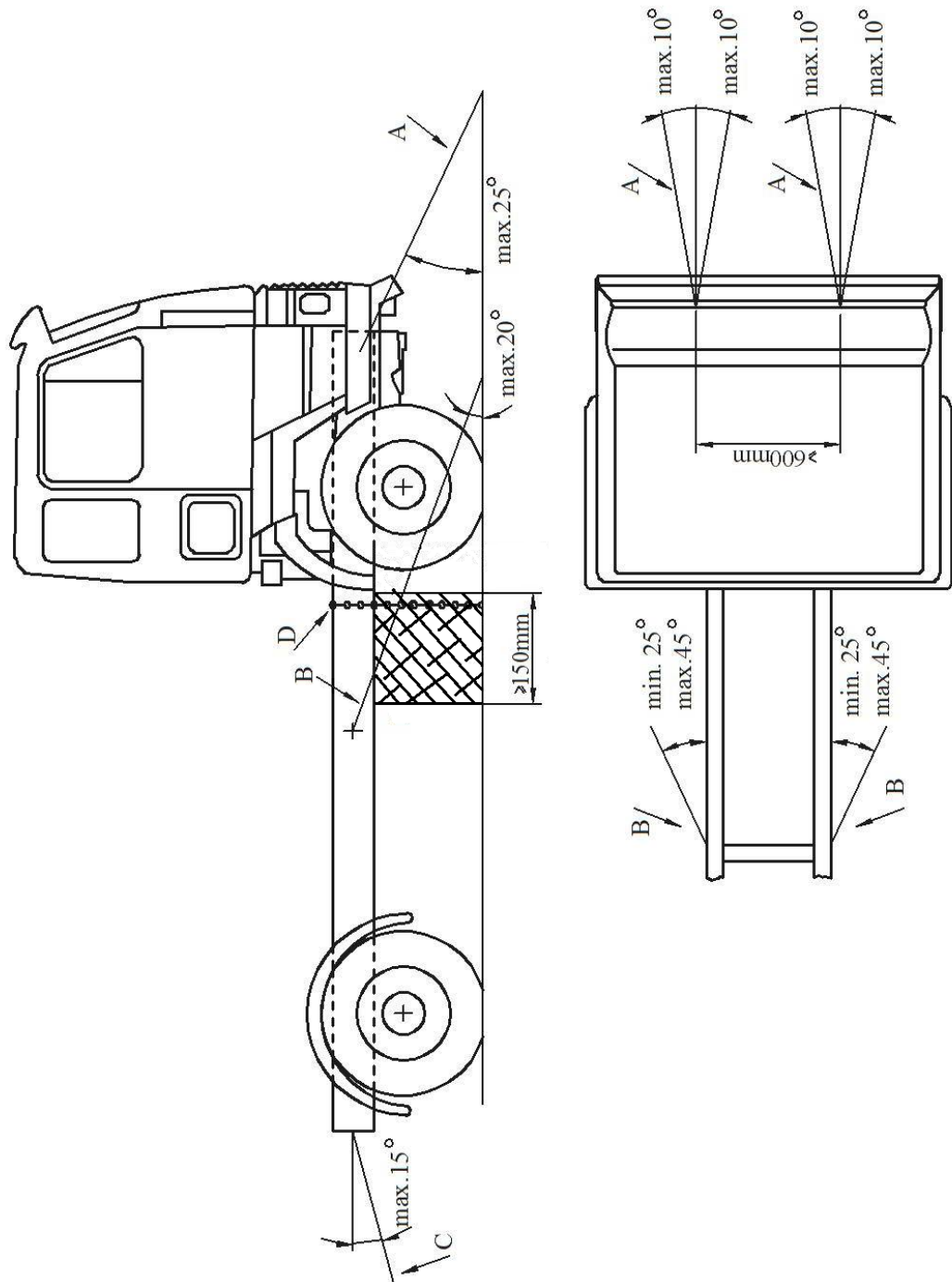

Figure 2  
Roof strength test  
The cab is mounted on the vehicle

