

24 February 2014

Agreement

Concerning the Adoption of Uniform Technical Prescriptions for Wheeled Vehicles, Equipment and Parts which can be Fitted and/or be Used on Wheeled Vehicles and the Conditions for Reciprocal Recognition of Approvals Granted on the Basis of these Prescriptions*

(Revision 2, including the amendments which entered into force on 16 October 1995)

Addendum 28 – Regulation No. 29

Revision 2 - Amendment 1

Supplement 1 to the 03 series of amendments – Date of entry into force: 13 February 2014

Uniform provisions concerning the approval of vehicles with regard to the protection of the occupants of the cab of a commercial vehicle



UNITED NATIONS

* Former title of the Agreement: Agreement Concerning the Adoption of Uniform Conditions of Approval and Reciprocal Recognition of Approval for Motor Vehicle Equipment and Parts, done at Geneva on 20 March 1958.

Annex 3,

Appendix 2,

The figure, amend to read:

"

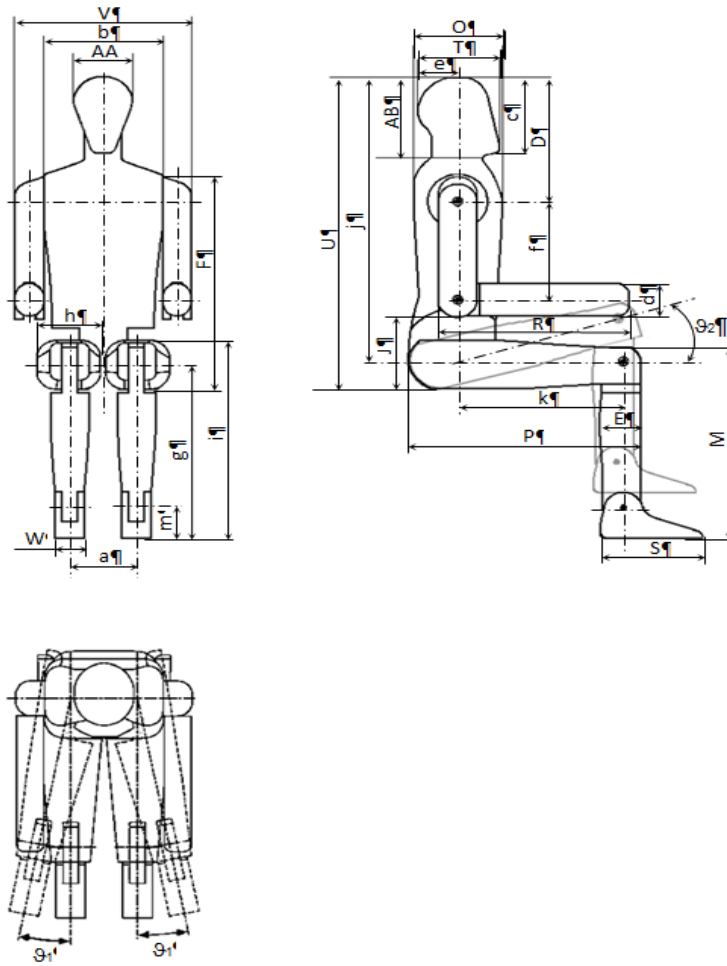

"

The table, amend to read:

"

<i>Dimensions</i>		
<i>Name</i>	<i>Description</i>	<i>Dimension in mm</i>
AA	Breadth of head	153
...
g ₁	Lateral rotation of the legs	20°
g ₂	Upward rotation of the legs	45°

"