

**Comments and amendment proposals to
ECE/TRANS/WP.29/GRVA/2020/21 (in purple)**

OICA supports the principles of the proposal from CLEPA. The EMB technology is clearly of importance for the development of electric vehicles.

This document brings some proposals to improve and finalize some open items in the proposal.

Proposal for Supplement 17 to the 11 series of amendments to UN Regulation No. 13 (Heavy vehicle braking)

Submitted by the expert from the European Association of Automotive Suppliers

The text reproduced below was prepared by the expert from the European Association of Automotive Suppliers (CLEPA) to include in UN Regulation No. 13 requirements for the type approval of Electro-Mechanical Braking (EMB) systems as state-of-the-art braking systems. The modifications to the existing text of the Regulation are marked in bold for new and strikethrough for deleted characters.

I. Proposal

Paragraph 2.21.4., amend to read:

2.21.4. "Electric state of charge" (SOC) means the instantaneous ratio of electric quantity of energy stored in a ~~traction~~ battery relative to the maximum quantity of electric energy which could be stored in this battery.

Paragraph 2.31., amend to read:

2.31. "Reference braking forces" means the braking forces of one axle generated at the circumference of the tyre on a roller brake tester, relative to brake actuator pressure **or wheel brake demand value respectively** and declared at the time of type approval.

Insert new paragraph 2.42., to read:

2.42. "**Electro-mechanical brake**" means a friction brake where electrical energy only is converted to actuating forces by purely mechanical means.

Insert new paragraph 2.43., to read:

2.43. "**Electro-mechanical braking system**" means a service braking system which is equipped with electro-mechanical brakes on all axles.

Insert new paragraph 2.44., to read:

2.44. "**Wheel brake demand value**" means the demand value for the braking force of a single wheel brake being electrically actuated.

Insert new paragraph 2.45., to read:

2.45. "**e_w**" means the low electrical energy warning level defined by the vehicle manufacturer according to paragraph 5.2.1.34.7. in the case of an electro-mechanical braking system.

Insert new paragraph 2.46., to read:

2.46. "**P_w**" means the low electrical supply power warning level as required by paragraph 5.2.1.34.8. in the case of an electro-mechanical braking system.

Insert new paragraph 2.47., to read:

2.47. "**Energy source**" means a device that converts a type of energy to the type of energy **required to actuate the brakes for the braking system**, either directly or indirectly through an electrical energy storage device(s).

Insert new paragraph 2.48., to read:

2.48. "**Electrical energy storage device**" means a device (e.g. battery, ultracapacitor) in the braking system that stores electrical energy used for generating braking forces.

Insert new paragraph 2.49., to read:

2.49. "**Electrical supply device**" means a device (e.g. battery, REESS, DC/DC converter, generator, fuel-cell) that supplies electrical energy to the braking system's electrical *energy* storage device(s).

<p>The Periodical Technical Inspection (PTI) requirements are not yet fully developed and are still under discussion. In particular, the data on the plate (see paragraph 5.1.4.5.3.) must enable the PTI inspector to check the condition of the braking system. However, the currently proposed data does not stipulate the procedure to accomplish that.</p>

Paragraph 5.1.4.5.1., amend to read:

5.1.4.5.1. The data of the compressed-air or **electro-mechanical** braking system for the functional and efficiency test shall be specified at the vehicle in a visible position in indelible form, or made freely available in another way (e.g. handbook, electronic data record).

Insert new paragraph 5.1.4.5.3., to read:

5.1.4.5.3. For power-driven vehicle equipped with electro-mechanical braking systems at least the following data have to be declared:

<i>Data declared</i>	<i>Unit</i>
Energy warning level e_w [Joule or kWh]
Low electrical supply power warning level P_w [W]
Nominal electrical energy storage capacity] [Joule or kWh]
Minimum usable electrical energy storage capacity] [Joule or kWh]

The ~~procedure~~ by which the PTI inspector can check that the monitoring of e_w and P_w by the electro-mechanical braking system and the relevant warning signal are operational shall be described by the vehicle manufacturer.

Where:

- (a) e_w is the low electrical energy warning level defined by the vehicle manufacturer according to paragraph 5.2.1.34.7.
- (b) P_w is the low electrical supply power warning level defined in paragraph 5.2.1.34.8.

Renumber current paragraphs 5.1.4.6.2. and 5.1.4.6.3. and insert as new paragraphs 5.1.4.6.1.1. and 5.1.4.6.1.2. to read:

5.1.4.6.1.1. Reference braking forces are to be determined for a brake actuator pressure range from 100 kPa to the pressure generated under Type-0 conditions for each axle. The applicant for type approval shall nominate reference-braking forces for a brake activator pressure range from 100 kPa. These data shall be made available, by the vehicle manufacturer, according to paragraph 5.1.4.5.1. above.

5.1.4.6.1.2. The reference braking forces shall be declared such that the vehicle is capable of generating a braking rate equivalent to that defined in Annex 4 of this Regulation for the relevant vehicle (50 per cent in the case of vehicles of category M₂, M₃, N₂, N₃, O₃ and O₄ except semi-trailers, 45 per cent in the case of semi-trailers), whenever the measured roller braking force, for each axle irrespective of load, is not less than the reference braking force for a given brake actuator pressure within the declared operating pressure range¹.

Insert new paragraphs 5.1.4.6.2. and 5.1.4.6.3., to read:

5.1.4.6.2. **Reference braking forces for electro-mechanical braking system using a roller brake tester shall be defined according to the following requirements.**

5.1.4.6.2.1. **It shall be possible on the vehicle to evaluate the relationship between the wheel brake demand value [e.g. as a percent value, voltage, etc.] and the required minimum braking force on a roller brake tester. The method by which this can be realized shall be declared by the vehicle manufacturer.**

¹ For the purpose of periodic technical inspection, the minimum limit braking rate values defined for the whole vehicle may need adjustment to reflect national or international in-service requirements.

5.1.4.6.2.2. Reference braking forces are to be determined for each axle for a **wheel** brake demand value from zero to a value corresponding to a braking force generated under Type-0 conditions. The applicant for type approval shall nominate these reference braking forces. These data shall be made available by the vehicle manufacturer, according to paragraph 5.1.4.5.1. above.

5.1.4.6.2.3. The reference braking forces shall be declared such that the vehicle is capable of generating a braking rate equivalent to that defined in Annex 4 of this Regulation for the relevant vehicle (50 per cent in the case of vehicles of category M₂, M₃, N₂, and N₃) whenever the measured roller braking force, for each axle irrespective of load, is not less than the reference braking force for a given wheel brake demand value within the declared operating brake demand value range¹.

Paragraph 5.2.1.5., amend to read:

5.2.1.5. Where use is made of energy other than the muscular energy of the driver there need not be more than one source of such energy, however:

(a) In the case of a driven energy source (hydraulic pump, air compressor, driven generator etc.) the means by which the device constituting that source is driven shall be as safe as practicable

(b) In the case of an undriven electrical supply device, compliance with the requirements of paragraph 5.2.1.34.11. is regarded as sufficient.

Paragraph 5.2.1.5.1., amend to read:

5.2.1.5.1. In the event of failure in any part of the transmission of a braking system, the feed to the part not affected by the failure shall continue to be ensured if required for the purpose of halting the vehicle with the degree of effectiveness prescribed for residual and/or secondary braking. This condition shall be met by ~~means of devices which can be easily actuated when the vehicle is stationary, or by~~ automatic means.

Insert a new paragraph 5.2.1.5.4., to read:

5.2.1.5.4. However, as an alternative to the provisions of paragraphs 5.2.1.5.1. and 5.2.1.5.2., for an electro-mechanical braking system these requirements are considered to be met if the requirements of paragraph 5.2.1.5.4.1. are satisfied.

5.2.1.5.4.1. After any single transmission failure it shall still be possible after eight full-stroke actuations of the service braking system control, to achieve, at the ninth application, at least the performance prescribed for the secondary braking system or, where secondary performance requiring the use of stored energy is achieved by a separate control, it shall still be possible after eight full-stroke actuations to achieve, at the ninth application, the residual performance prescribed in paragraph 5.2.1.4. of this Regulation. Each full application shall be for a 20 s duration and have a five second interval.

Paragraph 5.2.1.2.7.2., amend to read:

5.2.1.2.7.2. If the service braking force and transmission depend ... below. **In case of compressed-air braking systems**, in each service braking circuit in at least one of the air reservoirs a device for draining and exhausting is required in an adequate and easily accessible position;

Paragraph 5.2.1.8.1.1., amend to read:

5.2.1.8.1.1. A difference in transverse braking pressures **or wheel brake demand value on any axle** of:

(a) 25 per cent of the higher value for vehicle decelerations ≥ 2 m/s²;

- (b) A value corresponding to 25 per cent at 2 m/s^2 for decelerations below this rate.

Insert new paragraph 5.2.1.13.2., to read:

- 5.2.1.13.2.** In the case of an electro-mechanical braking system, the requirements of paragraph 5.2.1.34.7. shall apply instead of the requirements of paragraph 5.2.1.13.1. to this Regulation. The electrical energy storage devices may be used also by other vehicle systems as long as the energy consumption of these systems cannot cause the reserves of energy to fall under a level which ensures the prescribed service braking performance.

Paragraph 5.2.1.18., amend to read:

- 5.2.1.18. In the case of a vehicle authorized to tow a trailer of category O₃ or O₄ **which is equipped with a compressed-air braking system**, its braking system shall satisfy the following conditions:

Paragraph 5.2.1.26.3., amend to read:

- 5.2.1.26.3. Auxiliary equipment may be supplied with energy from the electric transmission of the parking braking system provided that the supply of energy is sufficient to allow the actuation of the parking braking system in addition to the vehicle electrical load under non-fault conditions. In addition, where the energy reserve is also used by the service braking system, the requirements of paragraph 5.2.1.27.7. **or in the case of electro-mechanical braking systems paragraph 5.2.1.34.10. respectively shall apply.**

Paragraph 5.2.1.27., amend heading to read:

- 5.2.1.27. Special additional requirements for service braking systems with electric control transmission **except without electro-mechanical braking systems**

Insert new paragraph 5.2.1.34., to read:

- 5.2.1.34. Special additional requirements for service braking systems with electro-mechanical braking system with and an electric control transmission**

Comment: is it what is meant?

Control transmission	Energy transmission	Relevant paragraph	
		5.2.1.27	5.2.1.34
Air	Air	NA	NA
Electrical (EBS)	Air	x	NA
Electrical (EMB control)	Electrical (EMB)	NA	x
Air	Electrical (EMB)	irrelevant, won't exist	

- 5.2.1.34.1. For electro-mechanical braking systems, the requirements of this paragraph 5.2.1.34. apply instead of those of paragraph 5.2.1.27. above.
- 5.2.1.34.2. The energy level in the electrical energy storage device(s) shall be sufficient to ensure the residual performance as laid down in paragraph 2.4. of Annex 4 to this Regulation by the actuation of the service brake control when the vehicle is capable of driving.
- 5.2.1.34.3. The manufacturer shall describe the functionality of the system triggering the warning levels e_w and P_w .
- 5.2.1.34.4. With the parking brake released, the service braking system shall be able to generate a static total braking force at least equivalent to that required by the prescribed Type-0 test, even when the ignition/start switch has been switched off and/or the key has been removed. In the case of power-driven vehicles equipped with an interface according to paragraph 5.1.3. and authorized to tow trailers of category O₃ or O₄, such vehicles shall provide

a full control signal for the service braking system of the trailer. It should be understood that sufficient energy is available in the energy transmission of the service braking system.

- 5.2.1.34.5. With an electrical energy supply feeding only the electric control transmission and in the event of a failure of the energy source of the electric control transmission, starting from the nominal value of the energy level, the full control range of the service braking system shall be guaranteed after twenty consecutive full stroke actuations of the service braking control. During the test, the braking control shall be fully applied for 20 seconds and released for 5 seconds on each actuation. It should be understood that during the above test, sufficient energy is available in the energy transmission to ensure full actuation of the service braking system. This requirement shall not be construed as a departure from the requirements of Annex 7, Part D.

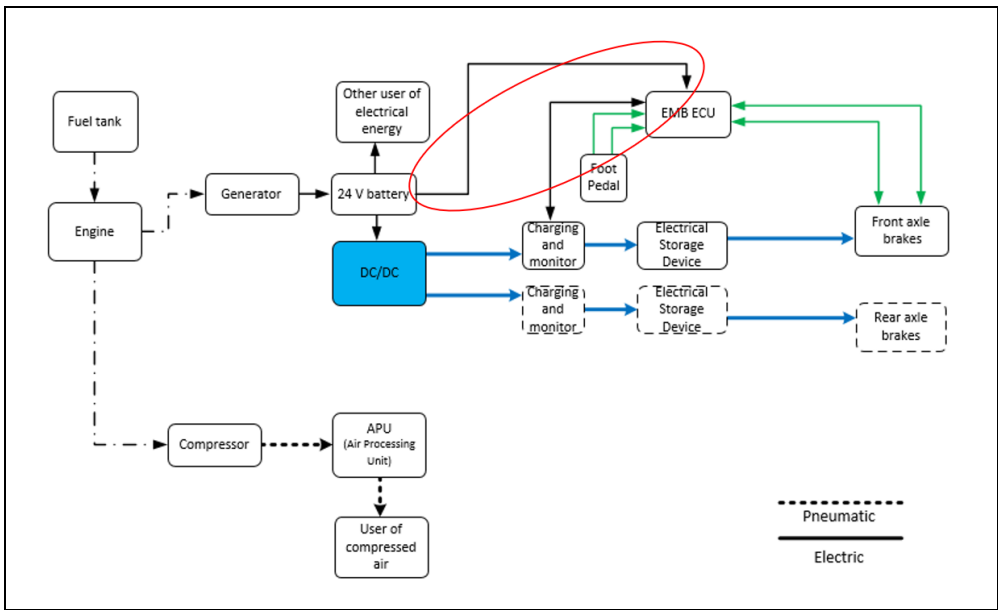

5.2.1.34.6. In the case that the electrical energy storage devices are also providing electrical energy for the electrical control transmission, the requirements of paragraph 1.2.1. of Part D of Annex 7 shall apply.

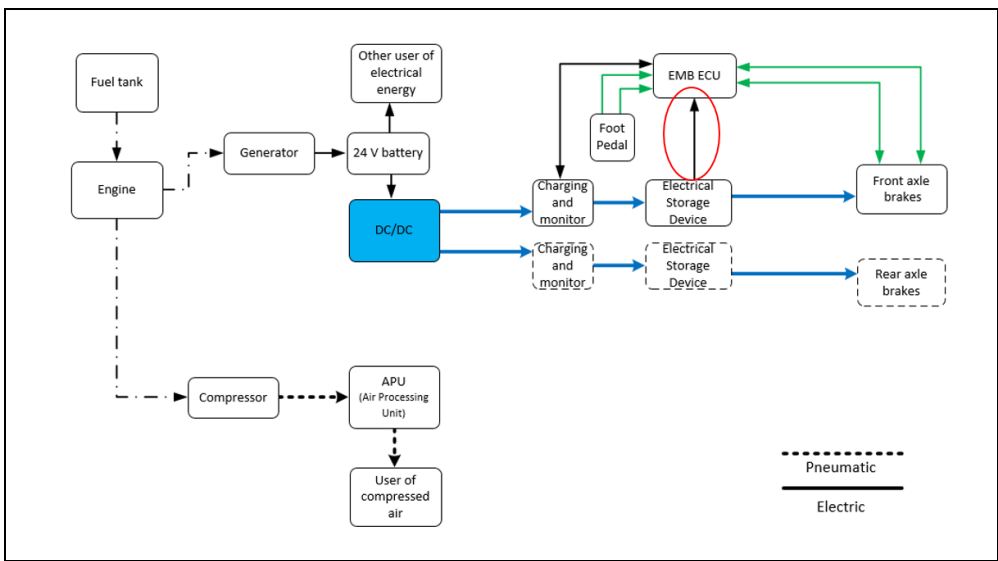

5.2.1.34.7. Any vehicle fitted with a service brake actuated from an electrical energy storage device shall, where the prescribed secondary braking performance cannot be obtained by means of this braking system without the use of the stored energy, be provided with a warning device, giving an optical or acoustic signal when the stored energy, in any part of the system, falls to a value e_w at which without re-charging of the electrical energy storage device and irrespective of the load conditions of the vehicle, it is possible to apply the service brake control a fifth time after four full-stroke actuations and obtain the prescribed secondary braking performance (without faults in the service brake transmission). This warning device shall be directly and permanently connected to the circuit. When the vehicle is running under normal operating conditions and there are no faults in the braking system, as is the case in approval tests for this type, the warning device shall give no signal except during the time required for charging the electrical energy storage device(s) from the

electrical supply device. The red warning signal specified in paragraph 5.2.1.29.1.1. shall be used as the optical warning signal.

5.2.1.34.8. When the supply of power requested by the electrical energy storage device(s) cannot be met by the electrical supply device and it falls below a value of P_w , declared by the manufacturer, a warning to the driver shall be activated. The yellow warning signal specified in paragraph 5.2.1.29.1.2. may be used.

5.2.1.34.8. When the supply of power ~~requested by the electrical energy storage device(s) cannot be met~~ by the electrical supply device ~~and it~~ falls below a value of P_w , declared by the manufacturer, a warning to the driver shall be activated. The yellow warning signal specified in paragraph 5.2.1.29.1.2. may be used.

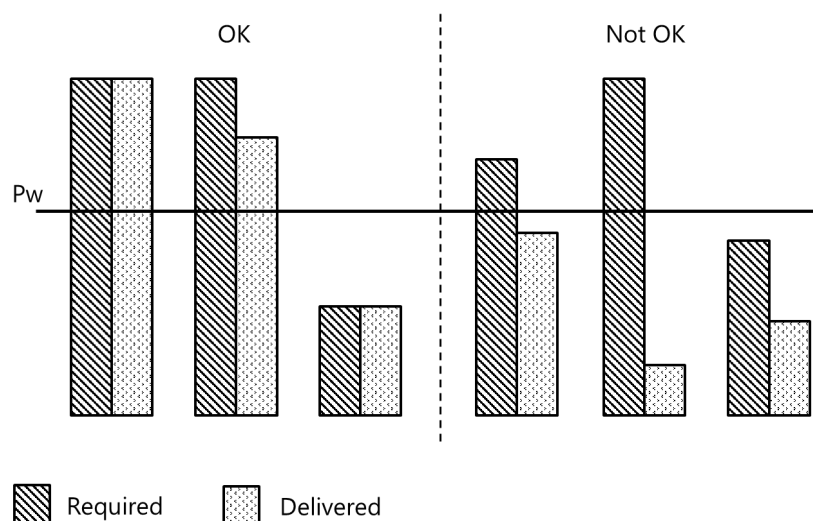

5.2.1.34.9. The red warning signal specified in paragraph 5.2.1.29.1.1. shall be activated when the service braking performance is not anymore ensured by at least two independent service braking circuits from each achieving the prescribed secondary or residual braking performance.

5.2.1.34.10. If auxiliary equipment is supplied with energy from the same electrical energy storage device(s) as the electric transmission, it shall be ensured that the supply of energy (in the case of a driven energy source with the engine running at a speed not greater than 80 per cent of the maximum power speed) is sufficient to fulfil the prescribed deceleration values by either provision of an energy supply which is able to prevent discharge of these reserves when all auxiliary equipment is functioning or by automatically switching off pre-selected parts of the auxiliary equipment at a level above the critical level referred to in paragraph 5.2.1.34.7. of this Regulation such that further discharge of these reserves is prevented. Compliance may be demonstrated by calculation or by a practical test. In the case of power-driven vehicles equipped with an interface according to paragraph 5.1.3. and authorized to tow a trailer of category O₃ or O₄ the energy consumption of the trailer shall be taken into account by a load of 400 W if this consumption is provided by the electrical energy storage device(s).

5.2.1.34.11. A failure within the electric transmission,¹ that affects the function and performance of systems addressed in this Regulation shall be indicated to

¹ Until uniform test procedures have been agreed, the manufacturer shall provide the Technical Service with an analysis of potential failures within the **electrical transmission** and their effects. This information shall be subject to discussion and agreement between the Technical Service and the vehicle manufacturer.

the driver by the red or yellow warning signal specified in paragraphs 5.2.1.29.1.1. and 5.2.1.29.1.2., respectively, as appropriate. When the prescribed service braking performance can no longer be achieved (red warning signal), failures resulting from a loss of electrical continuity (e.g. breakage, disconnection) shall be signalled to the driver as soon as they occur, and the prescribed residual braking performance shall be fulfilled by operating the service braking control in accordance with paragraph 2.4. of Annex 4 to this Regulation. These requirements shall not be construed as a departure from the requirements concerning secondary braking.

- 5.2.1.34.12. In the case of a single temporary failure (< 40 ms) within the electric control transmission, excluding its energy supply, (e.g. non-transmitted signal or data error) there shall be no distinguishable effect on the service braking performance.
- 5.2.1.34.13. In the case of a power-driven vehicle, electrically connected to a trailer via an electric control line, shall provide a clear warning to the driver whenever the trailer provides the failure information that the stored energy in any part of the service braking system on the trailer falls below the warning level, as specified in paragraph 5.2.2.16. below. A similar warning shall also be provided when a continuous failure (> 40 ms) within the electric control transmission of the trailer, excluding its energy reserve, precludes achievement of the prescribed service braking performance of the trailer, as specified in paragraph 5.2.2.15.2.1. below. The red warning signal specified in paragraph 5.2.1.29.2.1. shall be used for this purpose.
- 5.2.1.34.14. In the case of a failure in the electric control transmission of the service braking system of a towing vehicle equipped with an electric control line according to paragraph 5.1.3.1.2. or 5.1.3.1.3., the full actuation of the brakes of the trailer shall remain ensured.
- 5.2.1.34.15. If the auxiliary equipment is supplied with energy from the electric transmission, the following requirements shall be fulfilled.
- 5.2.1.34.15.1. In the event of a failure in the energy source or electrical supply device, whilst the vehicle is in motion, the energy in the electrical energy storage device(s) shall be sufficient to actuate the brakes when the control is applied.
- 5.2.1.34.15.2. In the event of a failure in the energy source or electrical supply device, whilst the vehicle is stationary and the parking braking system applied, the energy in the electrical energy storage device(s) shall be sufficient to actuate the lights even when the brakes are applied.

Annex 2

Insert new item 14.16., to read:

- 14.16. Vehicle is/is *not*² equipped with an electro-mechanical braking system**
- 14.16.1. In the case where a towing vehicle is equipped with an electro-mechanical braking system the vehicle is/is *not*² authorized to tow a trailer with a compressed-air braking system**

Annex 4,

Delete paragraph 1.2.11.

Paragraph 1.5.1.7.2., amend to read:

"In the case of vehicles equipped with hydraulically operated disc brakes **or electrically controlled adjustment mechanisms** no setting requirements are deemed necessary."

Insert new paragraph 4.1.4., to read:

- 4.1.4. In the case of vehicles fitted with an electro-mechanical braking system, the requirements of paragraph 4.1.1. above are considered to be satisfied if, in an emergency manoeuvre, the deceleration of the vehicle or the**

clamp force at the least favourable brake, reaches a level corresponding to the prescribed performance within 0.6 second.

Annex 7,

Insert new Part D, to read:

D. Electro-mechanical braking system

1. **Capacity of electrical energy storage devices**
 - General**
 - 1.1. Vehicles on which the operation of the braking system requires the use of electrical energy shall be equipped with electrical energy storage devices of a capacity meeting the requirements of paragraph 1.2. of this annex (Part D).
 - 1.1.2. It shall be possible to easily identify the electrical energy storage devices of the different circuits.
 - 1.2. **Power-driven vehicles**
 - 1.2.1. The electrical energy storage devices of power-driven vehicles shall be such that after eight full-stroke actuations of the service braking system control the energy level remaining in the electrical energy storage device(s) shall be not less than the energy level required to obtain the specified secondary braking performance. Each full application shall be for a 20 s duration and have a 5 s interval.
 - 1.2.2. Testing shall be performed in conformity with the following requirements:
 - 1.2.2.1. The initial energy level in the electrical energy storage device(s) shall be that specified by the manufacturer.¹ It shall be such as to enable the prescribed performance of the service braking system to be achieved;
 - 1.2.2.2. The electrical energy storage device(s) shall not be supplied with energy; in addition, any electrical energy storage device(s) for auxiliary equipment shall be isolated;
 - 1.2.2.3. In the case of power-driven vehicle to which the coupling of a trailer is authorized and with a pneumatic control line, the supply line shall be stopped and a compressed-air reservoir of 0.5 litre capacity shall be connected directly to the coupling head of the pneumatic control line. Before each braking operation, the pressure in this compressed-air reservoir shall be completely eliminated. After the test referred to in paragraph 1.2.1. above, at the additional (ninth) actuation of the service braking system control, the energy level supplied to the pneumatic control line shall not fall below a level equivalent to one-half the figure obtained at the first brake application.
2. **Capacity of the electrical supply device**
 - 2.1. **General**

The electrical supply device shall meet the requirements set forth in the following paragraphs.
 - 2.2. **Definitions**
 - 2.2.1. " e_1 " is the energy level corresponding after 8 full brake applications according to paragraph 1.2.1. above.
 - 2.2.2. " e_2 " is the value specified by the manufacturer and referred to in paragraph 1.2.2.1. above.
 - 2.2.3. " t_1 " is the time required for the energy level to rise from e_1 to e_2 .
 - 2.3. **Conditions of measurement**
 - 2.3.1. In the case that the generator is driven by the engine, the engine speed shall be in all testing conditions that obtained when the engine is running

¹ The initial energy level shall be stated in the approval document.

- at the speed corresponding to its maximum power or at the speed allowed by the governor.
- 2.3.2. In the case that the energy supply device is not an engine driven generator, it shall be able in all testing conditions to deliver its maximum power as declared by the manufacturer to the electrical energy storage device(s).
- 2.3.3. During the tests to determine the time t_1 , the electrical energy storage device(s) for auxiliary equipment shall be isolated.
- 2.4. Interpretation of results (Conditions of measurement as per paragraph 2.3.)
- 2.4.1. The time t_1 recorded for the least-favoured electrical energy storage device shall not exceed 6 minutes
- 2.5. Additional test
- 2.5.1. If the power-driven vehicle is equipped with one or more electrical energy storage devices for auxiliary equipment having a total capacity exceeding 20 per cent of the total capacity of the braking energy storage devices, an additional test shall be performed during which no irregularity shall occur in the operation of the devices controlling the supply of the electrical energy storage device(s) for auxiliary equipment.
- 2.5.2. The test shall be performed in the conditions prescribed in paragraphs 2.3.1. and 2.3.2. above.
3. Capacity of pneumatic energy sources
- In the case of vehicles to which the coupling of a trailer with a compressed-air braking system is authorized, also the following provisions apply:
- 3.1. Definitions
- 3.1.1. " p " = is the pressure in the pneumatic energy storage device(s) of an attached trailer with the capacity of at least the volume defined by paragraph 3.2.4.
- 3.1.2. " p_3 " = 450 kPa
- 3.1.3. " p_4 " = 700 kPa
- 3.1.4. " t_4 " is the time required for the relative pressure (of the attached trailer energy storage device with a volume as defined in paragraph 3.2.4.) to rise from 0 to p_3 , and " t_5 " is the time required for the relative pressure to rise from 0 to p_4 .
- 3.2. Conditions of measurement
- 3.2.1. In all cases, the speed of the compressor shall be that obtained when the engine is running at the speed corresponding to its maximum power or at the speed allowed by the governor.
- 3.2.2. During the tests to determine the time t_4 and the time t_5 , the pneumatic energy storage device(s) for auxiliary equipment shall be isolated.
- 3.2.3. In case that the supply line is not only fed directly by the energy source but also from an energy storage device of the motor vehicle, also the pressure in this compressed-air reservoir shall be completely eliminated.
- 3.2.4. The trailer shall be represented by a pneumatic energy storage device whose maximum relative pressure p (expressed in kPa / 100) is that which can be supplied through the towing vehicle's supply circuit and whose volume V , expressed in litres, is given by the formula $p \times V = 20 R$ (R being the permissible maximum mass, in tonnes, on the axles of the trailer).
- 3.3. Interpretation of results (Conditions of measurement as per paragraph 3.2.)

- 3.3.1. The time t_4 recorded for the least-favoured energy storage device shall not exceed 6 minutes
- 3.3.2. The time t_5 recorded for the least-favoured energy storage device shall not exceed 9 minutes
- 3.4. Additional test
- 3.4.1. If the power-driven vehicle is equipped with one or more pneumatic energy storage devices for auxiliary equipment, an additional test shall be performed during which no irregularity shall occur in the operation of the valves controlling the filling of the pneumatic energy storage device(s) for auxiliary equipment.
- 3.4.2. In the event of a failure in the pneumatic auxiliary equipment it shall be prevented that this failure cannot cause a pressure drop in the supply line (if present) below the pressure of 650 kPa.
- 3.4.3. It shall be verified during the aforesaid test that the time t_5 necessary to raise the pressure from 0 to p_4 in the attached trailer energy storage device is less than:
- 3.4.3.1. 11 minutes
- 3.4.3.2. The test shall be performed with all air reservoirs installed in the towing vehicle and with an attached trailer energy storage device of a volume as defined in paragraph 3.2.4.

Annex 8

Amend heading, to read:

Provisions relating to specific conditions for **compressed-air braking systems fitted with spring braking systems**

Annex 13, Appendix 2

Paragraph 1.1.3., amend to read:

- 1.1.3. A number of tests at increments of line pressure / *wheel brake demand value* shall be carried out to determine the maximum ...

Paragraph 5.1.1.3., amend to read:

- 5.1.1.3. **The supply to the energy transmission storage device(s) shall then be cut off.**

II. Justification

A. Regulation

(a) Paragraph 2.21.4.

1. The "State of Charge" (SOC) is commonly defined as the instantaneous ratio of electric quantity of energy stored in a device (compare also definitions in UN Global Technical Regulation No. 20 and UN Regulation No. 100).
2. In order to make use of the SOC-definition in other requirements (in Regulation No. 13) not related to the traction battery, the word "traction" is deleted from the definition of paragraph 2.21.4.
3. By this deletion it is possible to also make use of this definition for devices other than the traction battery (e.g. see current requirement 5.2.1.7.2.1. and new table of paragraph 5.1.4.5.3.).

(b) Paragraph 2.31.

4. Due to the new proposed EMB requirements, the wording "or wheel brake demand value respectively" is added.

(c) Paragraph 2.42.

5. This definition is inserted for clarification. In order to distinguish which requirements are related to the whole electro-mechanical braking system (see definition 2.43) and which requirements are related only to the electro-mechanical brake.

(d) Paragraph 2.43.

6. This definition is inserted to make the difference clear of what is commonly understood under an 'EBS system' where the control is generated and processed as an electrical signal in the control transmission and electrical output signals to devices which generate actuating forces produced from stored or generated pneumatic energy (in contrast to an electro-mechanical braking system which is actuated by electrical energy).

(e) Paragraph 2.44.

7. The wheel brake demand value for the single wheel brake is derived from the driver's brake demand value taking into account e.g. the loading conditions of the vehicle. This value determines the actual braking force.

(f) Paragraph 2.45.

8. This warning level is required by paragraph 5.2.1.34.7. and must be made available by the vehicle manufacturer according to paragraph 5.1.4.5.3.

(g) Paragraph 2.46.

9. This warning level is required by paragraph 5.2.1.34.8. and must be made available by the vehicle manufacturer according to paragraph 5.1.4.5.3.

(h) Paragraph 2.47.

10. Although the term "energy source" is used often in the current version of UN Regulation No. 13, it is not defined (however, it is defined in the agricultural braking Regulation (EU) 2015/68). With the introduction of the new term 'electrical supply device' (paragraph 2.49) it is seen as necessary to make the distinction clear between them. However, this definition should not imply that the 'energy source' in an electro-mechanical braking system is required equipment (see also 'electrical supply device', paragraph 2.49); i.e. an electro-mechanical braking system may include an 'energy source' in addition to an 'electrical supply device' or may be not included.

(i) Paragraph 2.48.

11. In contrast to pneumatic or hydraulic energy storage devices, there are in EMB systems different kinds of energy storage devices. The term "**electrical** energy storage device" should make clear that by this term the storage devices are meant which are only used for generating the braking force.

(j) Paragraph 2.49.

12. The definition of "electrical supply device" is introduced to clarify the interface to the braking system. This means that this device is not part of the braking system but part of another vehicle system (however, paragraph 5.2.1.34.8. requires that the supply provided by the electrical supply device to the braking system has to be monitored, however, no requirements are stipulated for the device itself).

(k) Paragraph 5.1.4.5.1.

13. The wording "**and electro-mechanical**" is added. It is seen that data for the functional and efficiency test shall also be made available for an electro-mechanical braking system.

(l) Paragraph 5.1.4.5.3.

14. In analogy to paragraph 5.1.4.5.2. it is proposed that some characteristic electrical energy storage and supply data have to be shown on the vehicle which can be checked during the periodical inspection.

15. The data on the plate must enable the PTI inspector to check the condition of the braking system. However, the currently proposed data does not state the exact procedure to accomplish that.

16. Therefore, this proposal must be developed further to be a practical procedure.

(m) Paragraphs 5.1.4.6.1.1. and 5.1.4.6.1.2.

17. These renumbered paragraphs are identical to former paragraphs 5.1.4.6.2. and 5.1.4.6.3.

(n) Paragraphs 5.1.4.6.2. and 5.1.4.6.3.

18. For an electro-mechanical braking system, the relationship between the brake actuator pressure and the braking force does not exist. Instead of the 'brake actuator pressure' the parameter 'wheel brake demand value' is used in determining the reference braking forces during a roller brake tester.

19. The manufacturer shall declare the relationship between the braking forces and the wheel brake demand value e.g. as a percent value or a voltage value.

20. During the periodical inspection, it shall be possible for the tester to monitor the wheel brake demand value on the vehicle itself. This may be done e.g. by showing this value by a display on the dashboard in the cab.

21. Apart from the different parameter 'wheel brake demand value' instead of 'brake actuator pressure' and the deletion of the category O vehicles, the requirements of the new inserted paragraph 5.1.4.6.2. relating to electro-mechanical braking systems are the same as for compressed-air braking systems.

(o) Paragraph 5.2.1.5.

22. Paragraph 5.2.1.5. clarifies that only one energy source is required for the braking system. Since up to now this energy source was only a driven device, the current paragraph 5.2.1.5 demands that the drive for this energy source "shall be as safe as practicable".

23. With EMB systems such a driven energy source might not be fitted. In order to make clear that the case of an 'undriven electrical supply device' no alternative requirement is demanded but only compliance with the general 'electric transmission failure' requirement of paragraph 5.2.1.34.11.

(p) Paragraph 5.2.1.5.1.

24. The current wording of paragraph 5.2.1.5.1. was formulated about 50 years ago. The optional permitted possibility to adjust the braking system **when the vehicle is stationary after a failure has occurred**, does not reflect the state-of-art and should therefore no longer be allowed.

25. This amendment also reflects the situation that an electro-mechanical braking system may have e.g. a 'multi-circuit supply protection electronics' fulfilling paragraph 5.2.1.5.1. by automatic means (as it is the case with conventional compressed-air braking systems).

(q) Paragraph 5.2.1.5.4.

26. Electro-mechanical braking systems (as hydraulic braking systems) do not have multi-protection valves which are normally fitted to compressed-air braking systems for which the requirements of paragraphs 5.2.1.5.1. and 5.2.1.5.2. apply. Therefore, in analogy to paragraph 5.2.1.5.3. (hydraulic braking systems), the requirements of paragraphs 5.2.1.5.4. and 5.2.1.5.4.1. are added. Analogue to paragraph 5.2.1.27.3., the last sentence (in bold characters) was added for clarification of the test procedure.

(r) Paragraph 5.2.1.2.7.2.

27. The addition in the last sentence of the wording "In case of compressed-air braking systems" is only a clarification that this requirement is only applicable for these kinds of braking systems.

(s) Paragraph 5.2.1.8.1.1.

28. Since an EMB system is not a compressed-air braking system it does not use different brake pressures for brake force compensation. A brake system using other energy sources as air should also be allowed to determine the brake force imbalance (caused by the deterioration or defect within the braking system) by controlling the difference in transverse wheel brake demand value.

(t) Paragraph 5.2.1.13.2.

29. Paragraph 5.2.1.13.1. addresses vehicles having an energy reservoir as an energy storage device which are fed by an energy source during driving.

30. Electro-mechanical braking systems do not have such conventional pneumatic or hydraulic energy reservoirs. Therefore, the relevant corresponding requirements to paragraph 5.2.1.13.1. appropriate for these braking systems are covered in paragraph 5.2.1.34.7. of the special EMB paragraph 5.2.1.34.

31. The second sentence ensures that not other systems make use of the same "electrical energy storage device" (e.g. braking and steering systems) at the same time with the result that no systems ensure the minimum performance requirements defined by these systems.

(u) Paragraph 5.2.1.18.

32. The addition of the wording "with a compressed-air braking system" is necessary since a power-driven vehicle cannot be authorized to a trailer of category O₃ or O₄ with an electro-mechanical braking system since for these types of trailer braking systems neither the relevant braking requirements nor an appropriate standardized interface exist.

(v) Paragraph 5.2.1.26.3.

33. Paragraph 5.2.1.27. does not address electro-mechanical braking systems. Due to the new proposed EMB requirements, the wording "**or in the case of electro-mechanical braking systems paragraph 5.2.1.34.10. respectively**" is added.

(w) Paragraph 5.2.1.27.

34. Since many requirements of this paragraph cannot be fully applied to EMB vehicles the current paragraph 5.2.1.27. is split up in two parts, namely of a paragraph addressing braking systems with non-electrical energy transmission (e.g. compressed-air braking systems - current paragraph 5.2.1.27.) and the new paragraph 5.2.1.34. "Special additional requirements for service braking systems with electro-mechanical braking system with electric transmission" (including both: electric control and energy transmission).

(x) Paragraph 5.2.1.34.

35. See above Justification as to paragraph 5.2.1.27.

(y) **Paragraph 5.2.1.34.2.**

36. This requirement ensures that it is not possible that a vehicle with an EMB systems can be driven on public roads without any service braking capabilities. Thus, this requirement reflects the situation that also power-driven vehicles with conventional braking systems cannot either be operated on public roads with the complete loss of the service braking system.

(z) **Paragraph 5.2.1.34.3.**

37. In order to avoid design restrictive requirements, manufacturers are required to provide documentation on the parameters and a description of the function triggering these warnings

(aa) **Paragraph 5.2.1.34.4.**

38. This paragraph corresponds to paragraph 5.2.1.27.1. The adding of the wording "**equipped with an interface according to paragraph 5.1.3. and**" clarifies that EMB motor vehicle are only permitted to tow trailers when they are equipped with an interface for trailers having a compressed-air braking system, see also comment as to paragraph 5.2.1.18.

(ab) **Paragraph 5.2.1.34.5.**

39. This requirement is similar to that in paragraph 5.2.1.27.5. but adapted to electro-mechanical braking system. Thus, in the beginning of this paragraph 5.2.1.34.5. the application of this requirement is clarified: "With an electrical energy supply feeding only the electric control transmission and in the event of ...". The term "**energy source**" is replaced by "**electrical energy supply**" since an "energy source" might not be installed on an electro-mechanical braking system.

40. Paragraph 5.2.1.34.5. addresses a configuration of an electro-mechanical braking system where an electrical energy storage device (e.g. battery) **only** supplies energy to the **control** transmission (but **not** to the electrical energy transmission as in the case with an EBS which has to comply with paragraph 5.2.1.27.5.); as an exemplary braking system see figure in paragraph 5.2.1.34.5.).

(ac) **Paragraph 5.2.1.34.6.**

41. In contrast to paragraph 5.2.1.34.5., this requirement addresses a configuration of an electro-mechanical braking system where energy storage devices are providing electrical energy for the electrical control and electrical energy transmission; as an exemplary braking system see figure in paragraph 5.2.1.34.6.).

(ad) **Paragraph 5.2.1.34.7.**

42. Paragraph 5.2.1.34.7. contains all corresponding and appropriate requirements of paragraph 5.2.1.13.1. which are relevant for electro-mechanical braking systems. Requirements which have no meaning or are not appropriate for EMB systems have been removed (see also Justification as to paragraph 5.2.1.13.2.) or have been adapted.

(ae) **Paragraph 5.2.1.34.8.**

43. This paragraph is an additional warning (as compared to conventional braking system) for the driver in case that the supply of power is insufficient.

(af) **Paragraph 5.2.1.34.9.**

44. This requirement is essentially a copy of paragraph 5.2.1.27.6. This requirement was introduced into UN R13 in the nineties (initiated by the passenger car industry) to avoid the situation that a driver may not get any warning when a vehicle (with a heavy front brake performance bias on the front axle) fulfils the prescribed service braking performance even in cases when one braking circuit fails completely.

(ag) Paragraph 5.2.1.34.10.

45. This requirement is similar to paragraph 5.2.1.27.7. However, since paragraph 5.2.1.34. covers not only the control transmission (as only covered by paragraph 5.2.1.27.) but also the electrical transmission, the electrical energy storage device for the whole transmission of the service braking system must be addressed by this paragraph. In consequence of this, the required warning level is that required by paragraph 5.2.1.34.7. (analogue to paragraph 5.2.1.13. addressing the electrical energy storage device for the whole transmission of the service braking system)

46. The energy consumption of the trailer shall only be considered if it is provided by the electrical energy storage device(s).

(ah) Paragraph 5.2.1.34.11.

47. This requirement is identical with paragraph 5.2.1.27.3. except that this requirement covers the whole electric transmission and not only the electric control transmission as addressed in paragraph 5.2.1.27.3.

(ai) Paragraph 5.2.1.34.12.

48. This requirement is identical with paragraph 5.2.1.27.2.

49. Since this requirement addresses only a failed or interrupted data transmission of the control signal, such a failure or interrupted data transmission is not relevant to be considered for the energy transmission.

(aj) Paragraph 5.2.1.34.13.

50. Except for the added and clarifying wording "**In the case of**" at the beginning of the text, this requirement is identical with paragraph 5.2.1.27.4.

(ak) Paragraph 5.2.1.34.14.

51. This requirement is identical with paragraph 5.2.1.27.9. In contrast to paragraph 5.2.1.18.2 which requires **partial** or **full** actuation of the trailer brakes, this paragraph requires that the **full** actuation of the trailer brakes remain ensured in the case of a failure in the electric control transmission of the service braking system.

(al) Paragraph 5.2.1.34.15.

52. This requirement is an adaption of paragraph 5.2.1.27.8. However, this paragraph refers to the **whole** electrical transmission (and **not only** to the electric **control** transmission). Instead of an energy source (EBS vehicles) the electrical energy may be supplied in the case of an electro-mechanical braking system by the "electrical supply device". Therefore, the wording of paragraph 5.2.1.27.8. was also modified.

B. Annex 2**Paragraph 14.16.**

53. The new paragraph 14.16. is added due the new requirements with regard to electro-mechanical braking systems.

C. Annex 4**(a). Paragraph 1.2.11.**

54. This paragraph is proposed to be deleted since no technical solutions have been provided during the last 20 years after its introduction. A traction battery to be charged externally only (without any possibility for re-charging, e.g. by recuperation) isn't state-of-the-art anymore.

(b) Paragraph 1.5.1.7.2.

55. Electrically controlled adjustment mechanisms measure and control the clearance between pad and disc constantly.

(c) Paragraph 4.1.4.

56. Since for EMB systems the special response time Annex 6 is not applicable, paragraph 4.1.4 is formulated like paragraph 4.1.3. for hydraulic systems which also do not fall under the scope of Annex 6.

D. Annex 7**(a) Part D**

57. With the development of electro-mechanical brakes there is the need to be able to homologate systems using stored electrical energy.

58. In Annex 7 currently there exists only requirements for pneumatic, vacuum and hydraulic systems (Part A to C) using stored energy but there are no corresponding requirements for braking systems using electrical energy storage devices.

59. In Part D the basic principles of parts A to C are applied. However, due to significant differences of EMB systems with conventional braking system (e.g. non-considered EMB trailer interface and the possibility of vehicles to be equipped without a generator), certain modifications have been introduced in this Part D.

(b) Paragraph 1.2.

60. Paragraph 1.2 is based on paragraph 1.2. of Part A. However, in analogy of paragraph 5.2.1.27.5., the last sentence was added in order to prescribe an objective testing method which may have an influence on the test result.

(c) Paragraph 1.2.2.

61. The testing conditions of paragraph 1.2.2. are the same as that of paragraph 1.2.2. of Part A.

(d) Paragraph 1.2.2.3.

62. Paragraph 1.2.2.3 (Part D) is in the version of paragraph 1.2.2.3. of Annex 7 Part A as amended during the 5th GRVA session in February 2020.

(e) Paragraphs 2.1. to paragraph 2.5.

63. The provisions of paragraphs 2.1. to paragraph 2.5. corresponds to that of paragraph 2. of Part A.

64. However, instead of pneumatic parameters electrical parameters are used. In addition, paragraph 2 of Part D does not only cover energy sources but also electrical supply devices which beside energy sources also include electrical energy storage devices; see definition of paragraph 2.49.

(f) Paragraph 3.1.

65. The pressure "p₂" in Part A corresponds to the pressure for achieving the prescribed performance of the service braking system during the Type-O test. Since this pressure is not available for an electro-mechanical braking system, the prescribed maximum supply line pressure of 700 kPa at which the Type O-test has to be carried out (see Annex 4, paragraph 3.1.3.2.) has taken to be the pressure p₄. With the supply line pressure of 700 kPa the prescribed service braking performance has to be achieved. Thus, this pressure is the worst-case assumption for achieving the prescribed service braking performance.

66. The pressure p₃ is the rounded 65per cent value of p₄ (compare paragraph 2.2.1. above).

(g) Paragraph 3.1.4.

67. In contrast to a compressed-air braking system, an electro-mechanical braking system has no air reservoirs providing energy to the service braking system of the motor vehicle. Therefore, for UN Regulation No. 13 as a braking regulation, only the respective filling times for the energy reserves of the braking system of the trailer (represented by the attached trailer energy storage device) has to be considered. The filling behaviour of a possibly existing air reservoir in the motor vehicle is indirectly also considered by the prescribed maximum filling times t_4 and t_5 (as the symbols t_1 to t_3 are already used in Part A of Annex 7, the subsequent indices '4' and '5' are used in this paragraph.)

(h) Paragraph 3.3.

68. The corresponding requirements as laid down in Part A (paragraph 2.4.) regarding the filling times for the attached trailer volume as defined by paragraph 3.2.4. are taken over.

(i) Paragraph 3.4.

69. In paragraph 2.5. of Part A of Annex 7, an additional test is prescribed in case if the power-driven vehicle is equipped with one or more energy storage devices for auxiliary equipment having a total capacity exceeding 20 per cent of the total capacity of the **pneumatic** braking energy storage devices. For an **electro-mechanical** braking system, an analogue "additional test" requirement is demanded by the newly proposed paragraph 2.5 of Part D of Annex 7.

70. This further 'additional test' of paragraph 3.4. is included in Part D of Annex 7 since an **electro-mechanical** braking system may also have **pneumatic** energy storage devices for **auxiliary** equipment fed by the same air compressor providing the air for the compressed-air braking system of the trailer. Thus, this test is added (independent on the size of the air reservoirs of the auxiliary equipment) to limit the maximum permitted filling time when **all** air reservoirs of a vehicle combination are filled up.

(j) Paragraph 3.4.2.

71. The performance braking requirements in UN Regulation No. 13 assume at least a pressure of 650 kPa in the supply line. Therefore, a failure in another vehicle system (e.g. air suspension) should not have an effect on the braking system that this assumed minimum pressure level is not anymore available.

72. The philosophy of this requirement is similar to that of the requirement of paragraph 5.2.1.15. in UN Regulation No. 13, where a failure of the trailer's braking system or in the event of an interruption in the supply line cannot cause the performance of the service braking system of the **motor** vehicle to fall under a certain performance level.

(k) Paragraph 3.4.3.1.

73. The corresponding requirements as laid down in Part A (paragraph 2.5.2.2.) regarding the filling times are taken over (see also the testing conditions defined in paragraph 3.4.3.2.).

E. Annex 8**Heading of Annex 8**

74. The requirements of Annex 8 assume a fluid to compress the spring in order to release a brake. Therefore, by adding in the heading the words "**compressed-air braking systems fitted with**" the scope of this section is made clear

F. Annex 13

(a) Paragraph 1.1.3.

75. Instead of the 'line pressure' the parameter 'wheel brake demand value' will be used to modify the individual brake forces within the k-measurement procedure.

(b) Paragraph 5.1.1.3.

76. The main demand of this requirement is that "any energy transmission storage device(s) shall not be charged". The editorial amendment of this paragraph makes it clear that also for electro-mechanical braking systems this demand has to be fulfilled and that this requirement cannot be circumvented by these braking systems by only switching of the engine.
