

Proposal for to the 04 series of amendments of Regulation No. 94 – protection of the occupants in the event of a frontal collision

Submitted by the experts from Japan on behalf of Task Force

The text reproduced below has been prepared by the expert from Japan on behalf of Task Force to amend the requirements concerning post-crash electrical safety in the event of frontal collision. The modifications to the current text of the Regulation are marked in bold for new or strikethrough for deleted characters.

I. Proposal

Throughout the document, replace term “electrical power train” with “**electric power train**”.

Paragraphs 2.16. to 2.20., amend to read:

"2.16. "Rechargeable Electrical Energy Storage System (REESS)" means the rechargeable energy storage system ~~that which~~ provides electrical energy for **electric** propulsion.

A battery whose primary use is to supply power for starting the engine and/or lighting and/or other vehicle auxiliaries' systems is not considered as a REESS. [Primary use in this context means that more than 50% of the energy from the battery is used for starting the engine and/or lighting and/or other vehicle auxiliaries' systems over an appropriate driving cycle, e.g. WLTC for M1 and N1.]

The REESS may include the necessary systems for physical support, thermal management, electronic control and enclosures.

2.17. "Electrical protection barrier" means the part providing protection against ~~any~~ direct contact to the high voltage live parts.

2.18. "~~Electrical~~ **Electric** power train" means the electrical circuit which includes the traction motor(s), and may also include the REESS, the electrical energy conversion system, the electronic converters, the associated wiring harness and connectors, and the coupling system for charging the REESS.

2.19. "Live parts" means conductive part(s) intended to be electrically energized **under normal operating conditions** ~~in normal use~~.

2.20. "Exposed conductive part" means the conductive part which can be touched under the provisions of the protection degree IPXXB and **which is not normally energized, but which can become** ~~which becomes~~ electrically energized under isolation failure conditions. This includes parts under a cover that can be removed without using tools."

Paragraph 2.27., amend to read:

"2.27. "Electrical circuit" means an assembly of connected ~~high voltage~~ live parts which is designed to be electrically energized in normal operation. "

Paragraphs 2.31. to 2.34., amend to read:

"2.31. "High voltage bus" means the electrical circuit, including the coupling system for charging the REESS, that operates on a high voltage.

Where electric circuits, that are galvanically connected to each other and fulfilling the specific voltage condition, only the components or parts of the

electric circuit that operate on high voltage are classified as a high voltage bus.

- 2.30. *"Solid insulator"* means the insulating coating of wiring harnesses, provided in order to cover and prevent the high voltage live parts from any direct contact. ~~This includes covers for insulating the high voltage live parts of connectors, and varnish or paint for the purpose of insulation.~~
- 2.31. *"Automatic disconnect"* means a device that when triggered, galvanically separates the electrical energy sources from the rest of the high voltage circuit of the ~~electric~~ electrical power train.
- 2.32. *"Open type traction battery"* means a type of battery requiring **filling with liquid and generating hydrogen gas that is released to the atmosphere.**

Insert new paragraphs 2.38. to 2.45., to read:

- 2.38. "Aqueous electrolyte" means an electrolyte based on water solvent for the compounds (e.g. acids, bases) providing conducting ions after its dissociation.**
- 2.39. "Electrolyte leakage" means the escape of electrolyte from the REESS in the form of liquid.**
- 2.40. "Non-aqueous electrolyte" means an electrolyte not based on water as the solvent.**
- 2.41. "Normal operating conditions" includes operating modes and conditions that can reasonably be encountered during typical operation of the vehicle including driving at legally posted speeds, parking and standing in traffic, as well as, charging using chargers that are compatible with the specific charging ports installed on the vehicle. It does not include, conditions where the vehicle is damaged, either by a crash, road debris or vandalization, subjected to fire or water submersion, or in a state where service and or maintenance is needed or being performed.**
- 2.42. "Specific voltage condition" means the condition that the maximum voltage of a galvanically connected electric circuit between a DC live part and any other live part (DC or AC) is ≤ 30 V AC (rms) and ≤ 60 V DC.**
- Note: When a DC live part of such an electric circuit is connected to electrical chassis and the specific voltage condition applies, the maximum voltage between any live part and the electrical chassis is ≤ 30 V AC (rms) and ≤ 60 V DC.**
- 2.43. "State of Charge (SOC)" means the available electrical charge in a REESS expressed as a percentage of its rated capacity.**
- 2.44. "Fire" means the emission of flames from the vehicle. Sparks and arcing shall not be considered as flames.**
- 2.45. "Explosion" means the sudden release of energy sufficient to cause pressure waves and/or projectiles that may cause structural and/or physical damage to the surrounding of the vehicle."**

Paragraphs 4.2. and 4.3., amend to read:

- 4.2. An approval number shall be assigned to each type approved in accordance with Schedule 4 of the Agreement (E/ECE/TRANS/505/Rev.3). ~~Its first two digits (at present 03 corresponding to the 03 series of amendments) shall indicate the series of amendments incorporating the most recent major technical amendments made to the Regulation at the time of issue of the approval. The same Contracting Party may not assign the same approval number to another vehicle type.~~**

- 4.3. Notice of approval or of refusal of approval of a vehicle type pursuant to this Regulation shall be communicated by the Parties to the Agreement which apply this Regulation by means of a form conforming to the model in Annex 1 to this Regulation ~~and photographs and/or diagrams and drawings supplied by the applicant for approval, in a format not exceeding A4 (210 X 297 mm) or folded to that format and on an appropriate scale. "~~

Paragraph 4.8., amend to read:

- "4.8. Annex 2 to this Regulation gives examples of **the arrangements of** approval marks."

Paragraphs 5.2.8. to 5.2.8.1.3., amend to read:

- "5.2.8. Following the test conducted in accordance with the procedure defined in Annex 3 to this Regulation, the electric ~~electrical~~ power train operating on high voltage, and the high voltage ~~components and systems,~~ which are galvanically connected to the high voltage bus of the electric power train, shall meet the following requirements:

- 5.2.8.1. Protection against electrical shock

After the impact, **the high voltage buses shall meet** at least one of the four criteria specified in paragraph 5.2.8.1.1. through paragraph 5.2.8.1.4.2. ~~below shall be met.~~

If the vehicle has an automatic disconnect function, or device(s) that ~~galvanically conductively~~ divide the electric power train circuit during driving condition, at least one of the following criteria shall apply to the disconnected circuit or to each divided circuit individually after the disconnect function is activated.

However criteria defined in 5.2.8.1.4. below shall not apply if more than a single potential of a part of the high voltage bus is not protected under the conditions of protection degree IPXXB.

~~If the~~ **In the case that the crash test is performed under the condition that part(s) of the high voltage system are not energized and with the exception of any coupling system for charging the REESS which is not energized during driving condition,** the protection against electrical shock shall be proved by either paragraph 5.2.8.1.3. or paragraph 5.2.8.1.4. below for the relevant part(s).

~~For the coupling system for charging the REESS, which is not energized during driving conditions, at least one of the four criteria specified in paragraphs 5.2.8.1.1. to 5.2.8.1.4. below shall be met.~~

- 5.2.8.1.1. Absence of high voltage

The voltages ~~V_b , V_1 and V_2~~ U_b , U_1 and U_2 of the high voltage buses shall be equal or less than 30 VAC or 60 VDC **within 60 s after the impact when measured in accordance with** ~~as specified in~~ paragraph 2. of Annex 11.

- 5.2.8.1.2. Low electrical energy

The Total Energy (TE) on the high voltage buses shall be less than ~~0.22-0~~ joules when measured according to the test procedure as specified in paragraph 3. of Annex 11 with the formula (a). Alternatively the total energy (TE) may be calculated by the measured voltage U_b ~~V_b~~ of the high voltage bus and the capacitance of the X-capacitors (C_x) specified by the manufacturer according to formula (b) of paragraph 3. of Annex 11.

The energy stored in the Y-capacitors (TE_{y1} , TE_{y2}) shall also be less than ~~0.22-0~~ joules. This shall be calculated by measuring the voltages U_1 and U_2 ~~V_1 and V_2~~ of the high voltage buses and the electrical chassis, and the capacitance of the Y-capacitors specified by the manufacturer according to formula (c) of paragraph 3. of Annex 11.

5.2.8.1.3. Physical protection

For protection against direct contact with high voltage live parts, the protection degree IPXXB shall be provided.

The assessment shall be conducted in accordance with paragraph 4 of Annex 11.

In addition, for protection against electrical shock which could arise from indirect contact, the resistance between all exposed conductive parts of **electrical protection barriers/enclosures** and the electrical chassis shall be lower than ~~0.1 Ω ohm~~ and the resistance between any two simultaneously reachable exposed conductive parts of electrical protection barriers/enclosures that are less than 2.5 m from each other shall be less than **0.2 Ω** when there is current flow of at least 0.2 ~~Amperes~~. This resistance may be calculated using the separately measured resistances of the relevant parts of electric path.

These requirements are ~~This requirement is~~ satisfied if the galvanic connection has been made by welding. **In case of doubt or the connection is established by mean other than welding, measurements shall be made by using one of the test procedures described in paragraph 4.1. of Annex 11."**

Paragraph 5.2.8.1.4.2., amend to read:

"5.2.8.1.4.2. ~~Electrical~~ **Electrical** power train consisting of combined DC- and AC-buses

If the AC high voltage buses and the DC high voltage buses are **conductively connected, they shall meet one of the following requirements:**

(a) **Isolation resistance between the high voltage bus and the electrical chassis shall have a minimum value of 500 Ω /V of the working voltage;**

(b) **Isolation resistance between the high voltage bus and the electrical chassis shall have a minimum value of 100 Ω /V of the working voltage and the AC bus meets the physical protection as described in paragraph 5.2.8.1.3;**

(c) **Isolation resistance between the high voltage bus and the electrical chassis shall have a minimum value of 100 Ω /V of the working voltage and the AC bus meets the absence of high voltage as described in paragraph 5.2.8.1.1.** ~~galvanically connected isolation resistance between the high voltage bus and the electrical chassis (R_i , as defined in paragraph 5. of Annex 11) shall have a minimum value of 500 Ω /V of the working voltage.~~

~~However, if the protection degree IPXXB is satisfied for all AC high voltage buses or the AC voltage is equal or less than 30 V after the vehicle impact, the isolation resistance between the high voltage bus and the electrical chassis (R_i , as defined in paragraph 5. of Annex 11) shall have a minimum value of 100 Ω /V of the working voltage. "~~

Paragraph 5.2.8.2., amend to read:

"5.2.8.2. Electrolyte ~~leakage~~~~spillage~~

~~In the period from the impact until 30 minutes after no electrolyte from the REESS shall spill into the passenger compartment and no more than 7 per cent of electrolyte shall spill from the REESS except open type traction batteries outside the passenger compartment. For open type traction batteries no more than 7 per cent with a maximum of 5.0 liters shall spill outside the passenger compartment.~~

~~The manufacturer shall demonstrate compliance in accordance with paragraph 6. of Annex 11.~~

5.2.8.2.1. In case of aqueous electrolyte REESS.

For a period from the impact until 60 minutes after the impact, there shall be no electrolyte leakage from the REESS into the passenger compartment and no more than 7 per cent by volume of the REESS electrolyte with a maximum of 5.0 l leaked from the REESS to the outside of the passenger compartment. The leaked amount of electrolyte can be measured by usual techniques of determination of liquid volumes after its collection. For containers containing Stoddard, coloured coolant and electrolyte, the fluids shall be allowed to separate by specific gravity then measured.

5.2.8.2.2. In case of non-aqueous electrolyte REESS.

For a period from the impact until 60 minutes after the impact, there shall be no liquid electrolyte leakage from the REESS into the passenger compartment, luggage compartment and no liquid electrolyte leakage to outside the vehicle. This requirement shall be verified by visual inspection without disassembling any part of the vehicle. "

Paragraph 5.2.8.3., amend to read:

"5.2.8.3. REESS retention

REESS shall remain attached to the vehicle by at least one component anchorage, bracket, or any structure that transfers loads from REESS to the vehicle structure, and REESS located outside the passenger compartment shall not enter the passenger compartment.

~~REESS located inside the passenger compartment shall remain in the location in which they are installed and REESS components shall remain inside REESS boundaries.~~

~~No part of any REESS that is located outside the passenger compartment for electric safety assessment shall enter the passenger compartment during or after the impact test.~~

~~The manufacturer shall demonstrate compliance in accordance with paragraph 7. of Annex 11. "~~

Insert new paragraph 5.2.8.4., to read:

"5.2.8.4. REESS fire hazards

For a period from the impact until 60 minutes after the impact, there shall be no evidence of fire or explosion from the REESS."

Paragraphs 7.1. to 7.3., amend to read:

"7.1. Every modification of the vehicle type with regard to this Regulation shall be notified to the Type Approval Authority which approved that vehicle type. The Type Approval Authority may then either:

- (a) Decide, in consultation with the manufacturer, that a new type

approval is to be granted; or

- (b) Apply the procedure contained in paragraph 7.1.1. (Revision) and, if applicable, the procedure contained in paragraph 7.1.2. (Extension).

7.1.1. Revision

When particulars recorded in the information documents have changed and the Type Approval Authority considers that the modifications made are unlikely to have appreciable adverse effect, and that in any case the vehicle still meets the requirements, the modification shall be designated a "revision".

In such a case, the Type Approval Authority shall issue the revised pages of the information documents of as necessary, marking each revised page to show clearly the nature of the modification and the date of re-issue. A consolidated, updated version of the information documents accompanied by a detailed description of the modification, shall be deemed to meet this requirement.

7.1.2. Extension

The modification shall be designated an "extension" if, in addition to the change of the particulars recorded in the information folder:

- (a) Further inspections or tests are required; or
- (b) Any information on the communication document (with the exception of its attachments) has changed; or
- (c) Approval to a later series of amendments is requested after its entry into force.

7.2. Notice of confirmation, extension, or refusal of approval shall be communicated by the procedure specified in paragraph 4.3. above, to the Contracting Parties to the Agreement applying this Regulation. In addition, the index to the information documents and to the test reports, attached to the communication document of Annex 1, shall be amended accordingly to show the date of the most recent revision or extension. "

Paragraph 8.1., amend to read:

"8.1. Every vehicle approved under this Regulation shall **be manufactured so as to conform to the vehicle type approved and satisfy the requirements set forth in paragraphs 5. and 6.;** ~~as regards features contributing to the protection of the occupants of the vehicle in the event of a frontal collision. "~~

Remove paragraph 8.2. and renumber paragraph (former) 8.3. as 8.2.

Paragraphs 9.1. and 9.2., amend to read:

"9.1. The approval granted in respect of a vehicle type pursuant to this Regulation may be withdrawn if the requirement laid down in paragraph 7.1. above is not complied with ~~or if the vehicle or vehicles selected have failed to pass the checks prescribed in paragraph 7.2. above.~~

9.2. If a Contracting Party to the Agreement applying this Regulation withdraws an approval it has previously granted, it shall forthwith so notify the other Contracting Parties applying this Regulation, by means of **a copy of the approval form bearing at the end, in large letters, the signed and dated annotation "APPROVAL WITHDRAWN"** ~~a communication form~~

~~conforming to the model in Annex 1 to this Regulation. "~~

Paragraph 10., amend to read:

"10. Production definitively discontinued

If the holder of the approval completely ceases to manufacture the type of vehicle approved in accordance with the Regulation, he shall so inform the Type Approval Authority which granted the approval. Upon receiving the relevant communication that Authority shall inform thereof the other Parties to the 1958 Agreement applying this Regulation by means of **a copy of the approval form bearing at the end, in large letters, the signed and dated annotation "PRODUCTION DISCONTINUED"**~~a communication form conforming to the model in Annex 1 to this Regulation. "~~

Remove existing Paragraph 11. "Transitional provision".

Renumber Paragraph 12 "Names and addresses of Technical Services responsible for conducting approval tests, and of Type Approval Authorities" as Paragraph 11.

Insert new Paragraph 12., to read:

"12. Transitional provisions

- 12.1. As from the official date of entry into force of the 04 series of amendments, no Contracting Party applying this Regulation shall refuse to grant or refuse to accept type-approvals under this Regulation as amended by the 04 series of amendments.**
- 12.2. As from 1 September [2023], Contracting Parties applying this Regulation shall not be obliged to accept type-approvals of vehicles having an electric power train operating on high voltage according to the 03 series of amendments, first issued after 1 September [2023].**
- 12.3. Contracting Parties applying this Regulation shall continue to accept type-approvals of vehicles not having an electric power train operating on high voltage according to the 03 series of amendments to the Regulation.**
- 12.4. Contracting Parties applying this Regulation shall not refuse to grant type-approvals according to any preceding series of amendments to this Regulation or extensions thereof.**
- 12.5. Notwithstanding the transitional provisions above, Contracting Parties who start to apply this Regulation after the date of entry into force of the most recent series of amendments are not obliged to accept type-approvals which were granted in accordance with any of the preceding series of amendments to this Regulation."**

Annex 3 paragraph 1.4.4.1., amend to read:

- "1.4.4.1. Procedures for SOC adjustment. ~~The REESS shall be at any state of charge, which allows the normal operation of the power train as recommended by the manufacturer.~~**
- 1.4.4.1.1. The adjustment of SOC shall be conducted at an ambient temperature of 20 ± 10 °C.**
- 1.4.4.1.2. The SOC shall be adjusted according to one of the following procedures as applicable. Where different charging procedures are possible, the REESS shall be charged using the procedure which yields the highest SOC:**

- (a) For a vehicle with a REESS designed to be externally charged, the REESS shall be charged to the highest SOC in accordance with the procedure specified by the manufacturer for normal operation until the charging process is normally terminated.
- (b) For a vehicle with a REESS designed to be charged only by an energy source on the vehicle, the REESS shall be charged to the highest SOC which is achievable with normal operation of the vehicle. The manufacturer shall advise on the vehicle operation mode to achieve this SOC.

1.4.4.1.3. When the vehicle is tested, the SOC shall be no less than 95 per cent of the SOC according to paragraphs 1.4.4.1.1. and 1.4.4.1.2. for REESS designed to be externally charged and shall be no less than 90 per cent of SOC according to paragraphs 1.4.4.1.1. and 1.4.4.1.2. for REESS designed to be charged only by an energy source on the vehicle. The SOC will be confirmed by a method provided by the manufacturer. "

Title of Annex 11., amend to read:

"Annex 11

Test procedures for the ~~protection of the occupants of vehicles equipped with electric power train operating on electrical power from high voltage and electrolyte spillage~~

Throughout Annex 11 (including Figures), replace the symbols for voltage, $V, V_b, V_1, V_1', V_2, V_2'$, with $U, U_b, U_1, U_1', U_2, U_2'$.

Preamble of Annex 11., amend to read:

"This annex describes test procedures to demonstrate compliance to the electrical safety requirements of paragraph 5.2.8. of this Regulation. ~~For example, megohmmeter or oscilloscope measurements are an appropriate alternative to the procedure described below for measuring isolation resistance. In this case it may be necessary to deactivate the on board isolation resistance monitoring system.~~

~~Before the vehicle impact test conducted, the high voltage bus voltage (V_b) (see Figure 1 below) shall be measured and recorded to confirm that it is within the operating voltage of the vehicle as specified by the vehicle manufacturer."~~

Annex 11, paragraph 2., amend to read:

- "2. The following instructions may be used if voltage is measured.
- After the impact test, determine the high voltage bus voltages (~~VU_b, VU_1, VU_2~~) (see Figure 1 below).
- The voltage measurement shall be made not earlier than ~~10~~ seconds, but, not later than 60 seconds after the impact.
- This procedure ..."

Annex 11, paragraph 3., amend to read:

- "3. Assessment procedure for low electrical energy
- Prior to the impact a switch S_1 and a known discharge resistor R_c is connected in parallel to the relevant capacitance (ref. Figure 2 below).

- (a) Not earlier than ~~10~~5 seconds and not later than 60 seconds after the impact the switch S1 shall be closed while the voltage ~~U_b~~~~V_b~~ and the current I_e are measured and recorded. The product of the voltage ~~U_b~~~~V_b~~ and the current I_e shall be integrated over the period of time, starting from the moment when the switch S1 is closed (t_c) until the voltage ~~U_b~~~~V_b~~ falls below the high voltage threshold of 60 V DC (t_h). The resulting integration equals the Total Energy (TE) in joules.

$$\text{(a)} \quad TE = \int_{t_c}^{t_h} U_b \times I_c dt$$

- (b) When ~~U_b~~~~V_b~~ is measured at a point in time between ~~10~~5 seconds and 60 seconds after the impact and the capacitance of the X-capacitors (C_x) is specified by the manufacturer, Total Energy (TE) shall be calculated according to the following formula:

$$\text{(b)} \quad TE = 0.5 \times C_x \times (\del{V_b} U_b^2 - 3600)$$

- (c) When ~~U₁~~ and ~~U₂~~ ~~V₁~~ and ~~V₂~~ (see Figure 1 above) are measured at a point in time between ~~10~~5 seconds and 60 seconds after the impact and the capacitances of the Y-capacitors (C_{y1}, C_{y2}) are specified by the manufacturer, Total Energy (TE_{y1}, TE_{y2}) shall be calculated according to the following formulas:

$$\text{(c)} \quad TE_{y1} = 0.5 \times C_{y1} \times (\del{V_1} U_1^2 - 3600)$$

$$TE_{y2} = 0.5 \times C_{y2} \times (\del{V_2} U_2^2 - 3600)$$

This procedure is not applicable if the test is performed under the condition where the electric power train is not energized."

Annex 11, paragraph 4., amend to read:

"4. Physical protection

Following the vehicle impact test any parts surrounding the high voltage components shall be, without the use of tools, opened, disassembled or removed. All remaining surrounding parts shall be considered part of the physical protection.

The jointed test finger described in ~~Figure 31 of Appendix 1~~ **Figure 3** shall be inserted into any gaps or openings of the physical protection with a test force of 10 N ± 10 per cent for electrical safety assessment. If partial or full penetration into the physical protection by the jointed test finger occurs, the jointed test finger shall be placed in every position as specified below.

Starting from the straight position, both joints of the test finger shall be rotated progressively through an angle of up to 90 degrees with respect to the axis of the adjoining section of the finger and shall be placed in every possible position.

Internal electrical protection barriers are considered part of the enclosure

If appropriate a low-voltage supply (of not less than 40 V and not more than 50 V) in series with a suitable lamp should be connected, between the jointed test finger and high voltage live parts inside the electrical protection barrier or enclosure.

Figure 3
Jointed Test Finger

Access probe
(Dimensions in mm)

IPXXB

Jointed text finger

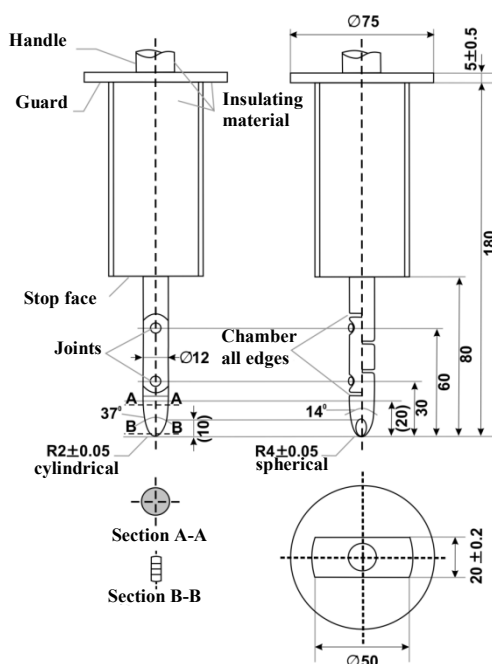

Material: metal, except where otherwise specified

Linear dimensions in mm.

Tolerances on dimensions without specific tolerance:

- (a) on angles: $+0/-10$ seconds;
- (b) on linear dimensions:
 - (i) up to 25 mm: $+0/-0.05$;
 - (ii) over 25 mm: ± 0.2 .

Both joints shall permit movement in the same plane and the same direction through an angle of 90° with a 0 to $+10^\circ$ tolerance.

~~4.1. Acceptance conditions~~

The requirements of paragraph 5.2.8.1.3. of this Regulation ~~are shall be considered to be~~ met if the jointed test finger described in Figure 31 ~~of Appendix 1~~, is unable to contact high voltage live parts.

If necessary a mirror or a fiberscope may be used in order to inspect whether the jointed test finger touches the high voltage buses.

If this requirement is verified by a signal circuit between the jointed test finger and high voltage live parts, the lamp shall not light.

4.1. Test method for measuring electric resistance:

- (a) Test method using a resistance tester.

The resistance tester is connected to the measuring points (typically, electrical chassis and electro conductive enclosure/electrical

protection barrier) and the resistance is measured using a resistance tester that meets the specification that follows:

- (i) Resistance tester: Measurement current at least 0.2 A;
 - (ii) Resolution: 0.01 Ω or less;
 - (iii) The resistance R shall be less than 0.1 Ω.
- (b) Test method using DC power supply, voltmeter and ammeter.

The DC power supply, voltmeter and ammeter are connected to the measuring points (Typically, electrical chassis and electro conductive enclosure/electrical protection barrier).

The voltage of the DC power supply is adjusted so that the current flow becomes at least 0.2 A.

The current "I" and the voltage "U" are measured.

The resistance "R" is calculated according to the following formula:

$$R = U / I$$

The resistance R shall be less than 0.1 Ω.

Note: If lead wires are used for voltage and current measurement, each lead wire shall be independently connected to the electrical protection barrier/enclosure/electrical chassis. Terminal can be common for voltage measurement and current measurement.

Example of the test method using DC power supply, voltmeter and ammeter is shown below.

Figure 4

Example of test method using DC power supply

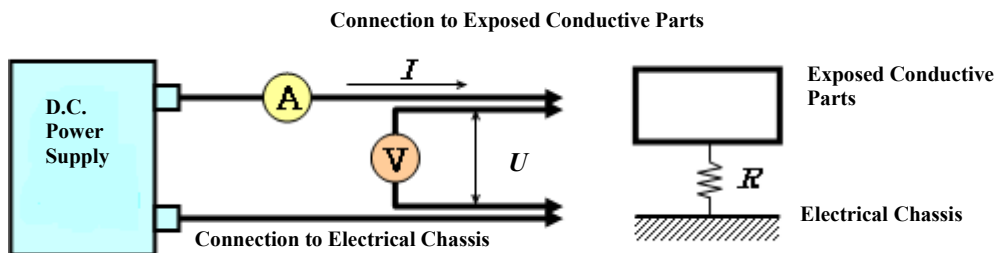

"

Annex 11, paragraph 5., amend to read:

"5. Isolation resistance

5.1. General.

The isolation resistance for each high voltage bus of the vehicle is measured or shall be determined by calculating the measurement values of each part or component unit of a high voltage bus.

All measurements for calculating voltage(s) and electrical isolation are made after a minimum of 10 s after the impact.

5.2. Measurement method.

The isolation resistance measurement is conducted by selecting an appropriate measurement method from among those listed in paragraphs 5.2.1. to 5.2.2. of this Annex, depending on the electrical charge of the live parts or the isolation resistance.

The range of the electrical circuit to be measured is clarified in advance, using electrical circuit diagrams. If the high voltage buses are conductively isolated from each other, isolation resistance shall be measured for each electrical circuit.

Moreover, modifications necessary for measuring the isolation resistance may be carried out, such as removal of the cover in order to reach the live parts, drawing of measurement lines and change in software.

In cases where the measured values are not stable due to the operation of the on-board isolation resistance monitoring system, necessary modifications for conducting the measurement may be carried out by stopping the operation of the device concerned or by removing it. Furthermore, when the device is removed, a set of drawings will be used to prove that the isolation resistance between the live parts and the electrical chassis remains unchanged.

These modifications shall not influence the test results.

Utmost care shall be exercised to avoid short circuit and electric shock since this confirmation might require direct operations of the high-voltage circuit.

5.2.1. Measurement method using DC voltage from external sources.

5.2.1.1. Measurement instrument.

An isolation resistance test instrument capable of applying a DC voltage higher than the working voltage of the high voltage bus shall be used.

5.2.1.2. Measurement method.

An isolation resistance test instrument is connected between the live parts and the electrical chassis. The isolation resistance is subsequently measured by applying a DC voltage at least half of the working voltage of the high voltage bus.

If the system has several voltage ranges (e.g. because of boost converter) in conductively connected circuit and some of the components cannot withstand the working voltage of the entire circuit, the isolation resistance between those components and the electrical chassis can be measured separately by applying at least half of their own working voltage with those components disconnected.

5.2.2. Measurement method using the vehicle's own REESS as DC voltage source.

5.2.2.1. Test vehicle conditions.

The high voltage-bus is energized by the vehicle's own REESS and/or energy conversion system and the voltage level of the REESS and/or energy conversion system throughout the test shall be at least the nominal operating voltage as specified by the vehicle manufacturer.

5.2.2.2. Measurement instrument.

The voltmeter used in this test shall measure DC values and have an internal resistance of at least 10 MΩ.

5.2.2.3. Measurement method.

5.2.2.3.1. First step.

The voltage is measured as shown in Figure 1 and the high voltage bus voltage (U_b) is recorded. U_b shall be equal to or greater than the nominal operating voltage of the REESS and/or energy conversion system as specified by the vehicle manufacturer.

5.2.2.3.2. Second step.

The voltage (U_1) between the negative side of the high voltage bus and the electrical chassis is measured and recorded (see Figure 1).

5.2.2.3.3. Third step.

The voltage (U_2) between the positive side of the high voltage bus and the electrical chassis is measured and recorded (see Figure 1).

5.2.2.3.4. Fourth step.

If U_1 is greater than or equal to U_2 , a standard known resistance (R_o) is inserted between the negative side of the high voltage bus and the electrical chassis. With R_o installed, the voltage (U_1') between the negative side of the high voltage bus and the electrical chassis is measured (see Figure 5).

The electrical isolation (R_i) is calculated according to the following formula:

$$R_i = R_o * U_b * (1/U_1' - 1/U_1)$$

Figure 5
Measurement of U_1'

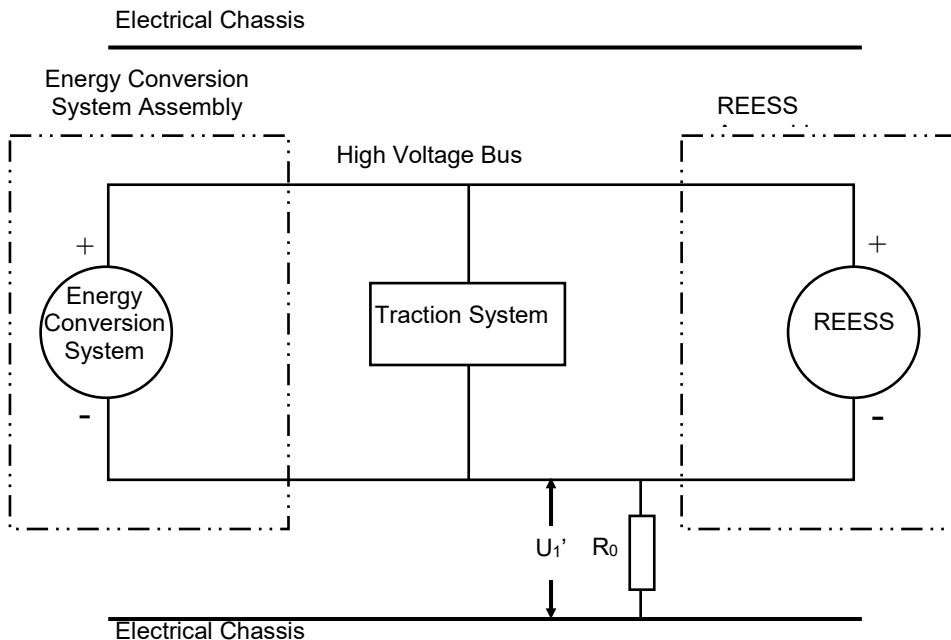

If U_2 is greater than U_1 , insert a standard known resistance (R_o) between the positive side of the high voltage bus and the electrical chassis. With R_o

installed, measure the voltage (U_2') between the positive side of the high voltage bus and the electrical chassis (see Figure 6 below). The electrical isolation (R_i) is calculated according to the following formula:

$$R_i = R_o * U_b * (1/U_2' - 1/U_2)$$

Figure 6
Measurement of U_2'

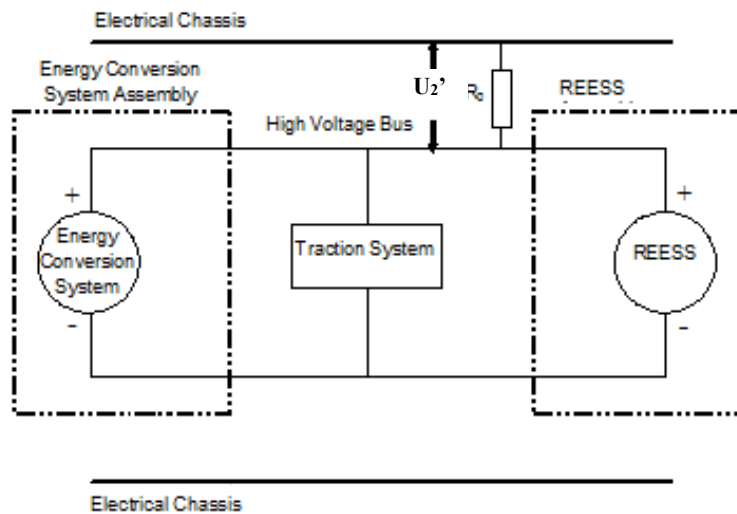

5.2.2.3.5. Fifth step.

The electrical isolation value R_i (in Ω) divided by the working voltage of the high voltage bus (in V) results in the isolation resistance (in Ω/V).

Note: The standard known resistance R_o (in Ω) should be the value of the minimum required isolation resistance (Ω/V) multiplied by the working voltage (V) of the vehicle plus/minus 20 per cent. R_o is not required to be precisely this value since the equations are valid for any R_o ; however, a R_o value in this range should provide a good resolution for the voltage measurements. "

Annex 11, paragraph 6., amend to read:

"6. Electrolyte leakage ~~spill~~

~~An appropriate coating shall be applied, if necessary, to the physical protection (casing) in order to confirm if there is any electrolyte leakage from the REESS after the impact resulting from the test. Unless the manufacturer provides means to differentiate between the leakage of different liquids, all liquid leakage shall be considered as the electrolyte.~~
An appropriate coating shall be applied, if necessary, may be applied to the physical protection (casing) in order to confirm if there is any electrolyte leakage from the REESS after the impact resulting from the test. Unless the manufacturer provides means to differentiate between the leakage of different liquids, all liquid leakage shall be considered as the electrolyte.

Annex 11, Appendix, removed.

II. Justification

1. The technical provisions of global technical regulation No.20 (GTR20) are adopted for UN Regulation No.94 with respect to the post-crash electrical safety.
2. Administrative provisions are adapted for the revision 3 of the 58 Agreement.
3. Since the proposed amendments are only related to the vehicles having electric power train operating at high voltage, the validity of the existing approvals for vehicles not having

electric power train are not affected. For the vehicles affected by this series of amendment, it is recommended to align the implementation timing with the amendment of UNR100 for transposing GTR20.
