

Transmitted by the expert
from the Russian Federation

Informal document GRB-64-01
(64th GRB, 5-7 September 2016,
agenda item 2)

Proposal for Supplement 5 to Regulation No. 28

The text reproduced below was prepared by the expert from the Russian Federation in addition to ECE/TRANS/WP.29/GRB/2016/4. It contains a number of comments to clarify the modifications made to the previous proposal in ECE/TRANS/WP.29/GRB/2016/2. The proposed amendments to the current Regulation are marked in bold for new or strikethrough for deleted characters.

I. Proposal

Regulation No. 28, amend to read:

"Uniform provisions concerning the approval of audible warning devices, ~~audible warning system, multiple audible warning system~~ and of motor vehicles with regard to their audible warning signals"

Comment [A1]: In this document green colour represents the additional proposals made by Japan by the Moscow meeting of interested experts held on 10 June 2016, blue colour indicates the outcome of that meeting

Contents

| Regulation | Page** |
|---|--------|
| 1. Scope | |
| I. Part I: Audible warning devices, audible warning system, multiple audible warning system | |
| 2. Definitions..... | |
| 3. Application for approval | |
| 4. Markings | |
| 5. Approval | |
| 6. Specifications | |
| 7. Modification and extension of approval of the type of the audible warning devices, audible warning system, multiple audible warning system and extension of approval | |
| 8. Conformity of production | |
| 9. Penalties for non-conformity of production | |
| 10. Production definitively discontinued | |
| II. Part II: Audible warning signals for motor vehicles..... | |
| 11. Definitions..... | |
| 12. Application for approval..... | |
| 13. Approval | |
| 14. Specifications | |
| 15. Modification and extension of approval of the type of the audible warning device vehicle type | |
| 16. Conformity of production..... | |
| 17. Penalties for non-conformity of production | |
| 18. Production definitively discontinued | |
| 18 19. Names and addresses of Technical Services responsible for conducting approval tests and administrative departments Type Approval Authorities | |

Annexes

- 1A. Communication concerning the approval (or refusal or withdrawal of approval or production definitely

** Page numbers will be added at a later stage.

- discontinued) of a type of audible warning device, **audible warning system or multiple audible warning system** for motor vehicles pursuant to Regulation No. 28.....
- ~~2.~~ **1B.** Communication concerning the approval (or refusal or withdrawal of approval or production definitely discontinued) of a vehicle type with regard to its audible **warning** signals pursuant to Regulation No. 28.....
 - ~~3.~~ **2.** Arrangement of the approval marks of the audible warning device.....
 - 3.** **Qualification criteria for anechoic space environment**
 - 4.** **Microphone positions for measurements of acoustic parameters of audible warning devices, audible warning system, multiple audible warning system**
 - 5.** **Microphone positions for measurements of audible warning signals of motor vehicles**

--- **Comment [52]:** Proposal by Japan

1. Scope

1.1. This Regulation applies to:

1.1.1. ~~PART I: audible warning devices (AWD)~~ Approval of ~~vehicle audible warning devices,~~ **audible warning system, multiple audible warning system**^{4/} supplied with direct or alternating current or compressed air, which are intended for fitting to motor vehicles of categories L₂₃ to L₅, M, ~~and N, and T,~~ excluding mopeds (categories L₁ and L₂^{1/})^{2/};

1.1.2. ~~PART II: audible signals~~^{3/} Approval of motor vehicles listed in 1.1.1. with regard to fitting of devices specified under Part I.

~~1.2. This Regulation does not apply to:~~

~~1.2.1. The approval of "Acoustic Vehicle Alerting System" (AVAS) with the primary purpose to fulfil UN Regulation No. [XXX] [The approval of Quiet Road Transport Vehicles with regard to their reduced audibility];~~

~~1.2.2. The approval of Quiet Road Transport Vehicles with regard to their reduced audibility.~~

I. **Part I. Audible warning devices, audible warning system, multiple audible warning system**

2. Definitions

~~For the purpose of this Regulation, audible warning devices (AWD) of different "types" shall be understood to mean devices essentially different from one another with respect to such matters as:~~

- ~~2.1. trade name or mark;~~
- ~~2.2. principles of operation;~~
- ~~2.3. type of electrical supply (direct or alternating current);~~
- ~~2.4. outer shape of case;~~
- ~~2.5. Shape and dimensions of diaphragm(s);~~
- ~~2.6. Shape or kind of sound outlet(s);~~

^{1/} As indicated in the Consolidated Resolution on the Construction of Vehicles (R.E.3) (ECE/TRANS/WP.29/78/Rev.3, para. 2).

^{4/} An AWD consisting of several sound outlets activated by a single power unit shall be regarded as an AWD.

^{2/} As defined in the Consolidated Resolution (R.E.3) (TRANS/SC1/WP29/78).

^{3/} An AWD consisting of several units, each emitting a sound signal and operated simultaneously by the actuation of a single control shall be regarded as an audible warning system.

Comment [A3]: Square brackets from category T have been removed by the meeting of 10 June 2016

Comment [A4]: This arrangement was proposed by France introduced to allow further extension of this Regulation to other audible warning devices not yet regulated at UN level. France also proposed to move the measurement methods to the Annexes, however this was not realised in this document since the specifications and measurement methods are mixed up, so that it had been considered too complicate to separate those, so no one could be able to recognise the previous text. That could be done, when requirements to new audible alerting systems will be added. Further paragraph 1.2. was deleted following the proposal by Japan

- 2.7. ~~Rated sound frequency or frequencies;~~"
- 2.8. ~~rated supply voltage;~~
- 2.9. ~~for devices supplied directly from an external compressed air source, rated operating pressure.~~
- 2.10. ~~The AWD is principally intended for:~~
 - 2.10.1 ~~motor cycles of a power less than or equal to 7 kW (class I)~~
 - 2.10.2 ~~vehicles of categories M and N and motor cycles of a power greater than 7 kW (class II)~~

For the purpose of this Regulation:

- 2.1. *"audible warning device"* means a device consisting of one or several sound emission outlets that are excited **simultaneously**, emitting an acoustic signal which is intended to give **audible warning of the presence of a vehicle in a dangerous road traffic situation and which is intentionally operated by a driver**;
- 2.2. *"audible warning system"* means a **combination of audible warning devices mounted on a common bracket** operated simultaneously by a single control;
- 2.3. *"multiple-tone audible warning system"* means a **combination of audible warning devices mounted on a common bracket** capable of functioning independently;
- 2.4. **Principles of operation of audible warning device, audible warning system, multiple audible warning system:**
 - 2.4.1. *"Pneumatic"* means a principle of operation **by an external compressed air source**;
 - 2.4.2. *"Electro-pneumatic"* means a principle of operation **by a compressed air source which is controlled by electrical supply (direct or alternating current)**;
 - 2.4.3. *"Electro-magnetic with resonator disc"* means a principle of operation **by electro-magnetic force and amplified by resonator disc**;
 - 2.4.4. *"Electro-magnetic with horn"* means a principle of operation **by electro-magnetic force and amplified by a horn**;
- 2.5. *"type of audible warning device (audible warning system, multiple audible warning system)"* means **audible warning devices (audible warning systems, multiple audible warning systems) not differing essentially from each other with respect to such matters as:**
 - 2.5.1. trade name or mark, ~~model-commercial name and/or number~~;
 - 2.5.2. **base designation:**
 - 2.5.2.1. for motor cycles of a power less than or equal to 7 kW (class I);
 - 2.5.2.2. for vehicles of categories M, N and T and motor cycles of a power greater than 7 kW (class II);
 - 2.5.3. principles of operation;
 - 2.5.4. **audible warning devices, audible warning systems, multiple audible warning systems with electrical supply:**

Comment [A5]: OICA GRB-62-21-Rev.1

Comment [A6]: India GRB-62-18

Comment [B7]: Proposal by Japan

Comment [A8]: These four definitions have been added by Japan and refined by the Russian Federation after the meeting of 10 June 2016.

Comment [A9]: India GRB-62-18

Comment [A10]: "principal" changed to "base". See India GRB-62-18

- 2.5.4.1. type of electrical supply (direct or alternating current);
- 2.5.4.2. shape and dimensions of diaphragm(s);
- 2.5.4.3. rated **supply** voltage;
- 2.5.5. **audible warning devices, audible warning systems, multiple audible warning systems** supplied directly from an external compressed air source:
 - 2.5.5.1. rated operating pressure;
- 2.5.6. outer shape of a case;
- 2.5.7. shape or kind of sound outlet(s);
- 2.5.8. rated sound frequency or frequencies;
- 2.5.9. shape and dimensions of rigid connections for audible warning system, **or multiple audible warning system.**

3. Application for approval

- 3.1. The application for approval of a type of audible warning device (**system**) shall be submitted by the holder of the trade name or mark **its manufacturer** or by his duly accredited representative.
- 3.2. ~~It shall be accompanied by the following documents~~ **a duly filled technical information document, either in paper format in triplicate or alternatively upon agreement with the Type Approval Authority in electronic format. A model of the technical information document is shown in Annex 1A, giving the following particulars:**
 - ~~3.2.1. a description of the type of audible warning device (**system**), paying particular attention to the points mentioned in paragraph 2.2.4;~~
 - ~~3.2.2. A drawing showing, inter alia, the warning device in cross section;~~
 - ~~3.2.3.2. a list of the components used in manufacture **production**, duly identified, with an indication of the materials used;~~
 - ~~3.2.4.3. detailed drawings:~~
 - ~~3.2.3.1. of the warning device in cross section;~~
 - ~~3.2.3.2. of all the components used in manufacture **production**.~~
 - ~~3.2.3.3. The drawings shall show the place provided for the approval number in relation to the circle of the approval mark. **drawings showing the place provided for the approval number in relation to the circle of the approval mark and the location and the appearance of trade name or mark of the manufacturer of the warning device (system);**~~
- 3.3. In addition, the application for approval shall be accompanied by two samples of the type of ~~warning device (system)~~ **audible warning device, audible warning system, multiple audible warning system.**
- 3.4. The ~~competent authority~~ **Type Approval Authority** shall verify the existence of satisfactory arrangements for ensuring effective control of the conformity of production before type approval is granted.

Comment [B11]: Combined text by OICA, Japan and Russian Federation.

Comment [B12]: The subparagraphs were deleted following the proposal by Japan

4. Markings

- 4.1. ~~The samples of the audible warning devices submitted for approval shall bear the manufacturer's trade name or mark; this mark must be clearly legible and indelible.~~
- 4.2. ~~Each sample shall have a space of adequate dimensions for the approval mark; this space shall be indicated in the drawing referred to in paragraph 3.2.2.~~
- 4.1. Audible warning devices and each sound emitting component of an audible warning system or multiple audible warning system excluding mounting accessories, shall bear:
- 4.1.1. The trade name or mark of the manufacturer ~~of the system or its components~~ and the model commercial name and/or number;
- 4.1.2. The approval mark according to paragraph 5.5.
- 4.2. The approval mark shall be shown on the audible warning device, audible warning system, or multiple audible warning system according to paragraph 5.5. Each sample shall have a space of adequate dimensions for the approval mark; this space shall be indicated in the drawing ~~referred to in paragraph 3.2.3.3.~~
- 4.3. All markings shall be clearly legible and indelible.

Comment [A13]: India GRB-62-18

Comment [A14]: India GRB-62-18

Comment [A15]: India GRB-62-18

5. Approval

- 5.1. If the ~~two~~ samples submitted for approval conform to the provisions of paragraphs 6. ~~and 7.~~ below, approval for this type of ~~warning device~~ audible warning device, audible warning system, multiple audible warning system shall be granted.
- 5.2. An approval number shall be assigned to each type approved. Its first two digits (at present 00 for the Regulation in its original form) shall indicate the series of amendments incorporating the most recent major technical amendments made to the Regulation at the time of issue of the approval. The same Contracting Party may not assign this number to another type of audible warning device, audible warning system, multiple audible warning system.
- 5.3. The same approval number may be assigned to types of ~~warning device~~ audible warning device, audible warning system, multiple audible warning system differing only with respect to rated voltage, rated frequency or frequencies or ~~for the devices or the system mentioned in paragraph 2.8. 2.4.5. above,~~ rated operating pressure.
- 5.4. Notice of ~~Communication on~~ approval or refusal or extension or withdrawal of approval or production definitely discontinued of a type of a ~~warning device~~ audible warning device, audible warning system, multiple audible warning system pursuant to this Regulation shall be communicated to the Parties to the Agreement applying this Regulation by means of a form conforming to the model in Annex IA to the Regulation, ~~and of drawings of the audible warning device (supplied by the applicant for approval) with maximum format A.4 (210 x 297 mm) or folded to this format and on the scale 1:1.~~
- 5.5. On every audible warning device, audible warning device, audible warning system, multiple audible warning system which conforms to a type approved

under this Regulation, there shall be affixed conspicuously, in an easily accessible place indicated on the approval form, an international approval mark comprising:

- 5.5.1. a circle containing the letter "E" followed by the distinguishing number of the country granting approval;²
 - 5.5.2. an approval number;
 - 5.5.3. an additional symbol in the form of a figure in Roman numerals, showing the class to which the **AWD audible warning device (system), audible warning system or multiple audible warning system** belongs
- ~~5.6. The approval mark and the additional symbol must be clearly legible and indelible.~~
- ~~5.7.5.6. Annex 3 2, Section 4 I, to this Regulation gives an example of the arrangement of the approval mark.~~
- 5.7. The Type Approval Authority or its duly accredited technical service shall verify the arrangements of the marks for ensuring effective control of the conformity of production before type approval is granted.**

6. Specifications

- 6.1. General specifications
- 6.1.1. The audible warning device, **audible warning system or multiple audible warning system** shall emit a continuous and uniform sound; its acoustic spectrum shall not vary substantially during its operation.

For **audible warning devices, audible warning system or multiple audible warning system** supplied with alternating current, this requirement shall apply only at constant generator speed, within the range specified in paragraph ~~6.2.3.2. 6.3.3.2. 6.3.4.2.~~"

The type approval tests shall be carried out on two samples of each type submitted by the manufacturer for approval; both the samples shall be

² ~~1 for Germany, 2 for France, 3 for Italy, 4 for the Netherlands, 5 for Sweden, 6 for Belgium, 7 for Hungary, 8 for the Czech Republic, 9 for Spain, 10 for Yugoslavia, 11 for the United Kingdom, 12 for Austria, 13 for Luxembourg, 14 for Switzerland, 15 (vacant), 16 for Norway, 17 for Finland, 18 for Denmark, 19 for Romania, 20 for Poland, 21 for Portugal, 22 for the Russian Federation, 23 for Greece, 24 for Ireland, 25 for Croatia, 26 for Slovenia, 27 for Slovakia, 28 for Belarus, 29 for Estonia, 30 (vacant), 31 for Bosnia and Herzegovina, 32 for Latvia, 33 (vacant), 34 for Bulgaria, 35-36 (vacant), 37 for Turkey, 38-39 (vacant), 40 for The former Yugoslav Republic of Macedonia, 41 (vacant), 42 for the European Community (Approvals are granted by its Member States using their respective ECE symbol), 43 for Japan, 44 (vacant), 45 for Australia, 46 for Ukraine and 47 for South Africa. Subsequent numbers shall be assigned to other countries in the chronological order in which they ratify or accede to the Agreement Concerning the Adoption of Uniform Technical Prescriptions for Wheeled Vehicles, Equipment and Parts which can be Fitted and/or be Used on Wheeled Vehicles and the Conditions for Reciprocal Recognition of Approvals Granted on the Basis of these Prescriptions, and the numbers thus assigned shall be communicated by the Secretary General of the United Nations to the Contracting Parties to the Agreement." The distinguishing numbers of the Contracting Parties to the 1958 Agreement are reproduced in Annex 3 to the Consolidated Resolution on the Construction of Vehicles (R.E.3) (ECE/TRANS/WP.29/78/Rev.3).~~

subjected to all the tests and must conform to the technical specifications laid down.

- 6.1.2. The audible warning device, audible warning system or multiple audible warning system shall have acoustic characteristics (spectral distribution of the acoustic energy, sound pressure level) and mechanical characteristics such that it passes, in the order indicated, the following tests according to paragraphs 6.3. and 6.4.

6.2. Measuring instruments

- 6.2.2. ~~The measurements of the sound pressure levels shall be made with a class 1 precision sound level meter conforming to the specifications of IEC Publication No. 651, first edition (1979).~~

~~All measurements shall be made using the time constant "F". The measurement of the over-all sound pressure level shall be made using the weighting curve A.~~

6.2.1. Acoustic measurements

- 6.2.1.1. When no general statement or conclusion can be made about conformance of the sound level meter model to the full specifications of IEC 61672-1:2013³, the apparatus used for measuring the sound pressure level shall be a sound level meter or equivalent measurement system meeting the requirements of Class 1 instruments as described in IEC 61672-3:2013³. Measurements shall be carried out using the "fast" response of the acoustic measurement instrument and the "A" weighting curve also described in IEC 61672-1:2013³. When using a system that includes a periodic monitoring of the A-weighted sound pressure level, a reading should be made at a time interval not greater than 30 ms.

~~When measurements of the sound pressures in the one-third mid-band frequencies 2,000, 2,500 and 3,150 Hz are carried out for one-third octaves, the instrumentation shall meet all requirements of IEC 61260-1-2013²⁰¹⁴³, class 1. The spectrum of the sound emitted shall be measured according to the Fourier transform of the acoustic signal. Alternatively, one-third octave filters conforming to the specifications of IEC "61260-1:2004 Electroacoustics—Octave-band and fractional octave-band filter" may be used: in this case, t The sound pressure level in the mid-band frequency 2,500 Hz shall be determined by adding the quadratic means of the sound pressures in the one-third mid-band frequencies 2,000, 2,500 and 3,150 Hz. In every case, only the Fourier transform method shall be regarded as a reference method."~~

When measurements the rated frequency (or frequencies), the digital sound recording system shall have at least a 16 bit quantization. The average auto power spectrum shall be determined, using a Hanning window and at least 66.6% overlap averages.

The instruments shall be maintained and calibrated in accordance with the instructions of the instrument manufacturer.

- 6.2.1.2. Calibration of the entire Acoustic Measurement System for a Measurement Session

Comment [A516]: France GRB-62-20. The publication year of the standard is corrected to 2013. A footnote allowing the use of the previous versions of the standards was added by the Russian Federation following the proposal by Japan.

Comment [A517]: France GRB-62-20. The publication year of the standard is corrected to 2013.

³ For the purpose of this Regulation, the previous versions of the standards IEC 61672-1:2004 and IEC 61672-3:2004 2006 may be applied.

At the beginning and at the end of every measurement session the entire measurement system shall be checked by means of a sound calibrator that fulfils the requirements for sound calibrators of at least precision Class 1 according to IEC 60942:2003. Without any further adjustment the difference between the readings of two consecutive checks shall be less than or equal to 0.5 dB.

If this value is exceeded, the results of the measurements obtained after the previous satisfactory check shall be discarded.

6.2.1.3. Compliance with requirements

Compliance of the sound calibrator with the requirements of IEC 60942:2003 and compliance of the instrumentation system with the requirements of IEC 61672-3:2013³ shall be confirmed by the existence of a valid certificate of compliance.

6.2.2. Instrumentation for other measurements

The voltage shall be measured with instrumentation having an accuracy of ± 0.05 V or better.

The resistance shall be measured with instrumentation having an accuracy of ± 0.01 Ω or better.

The distance shall be measured with instrumentation having an accuracy of ± 5 mm or better.

The time shall be measured with instrumentation having an accuracy of ± 0.02 s or better.

The meteorological instrumentation used to monitor the environmental conditions during the test shall include the following devices, which meet at least the following accuracy:

- (a) Temperature measuring device, $\pm 1^\circ$ C;
- (b) Wind speed-measuring device, ± 1.0 m/s;
- (c) Barometric pressure measuring device, ± 5 hPa;
- (d) A relative humidity measuring device, ± 5 per cent."

6.2.6.3. Measurement of the sound characteristics.

~~6.2.4-6.3.1.~~ The audible warning device, audible warning system or multiple audible warning system should, preferably, be tested in an anechoic environment chamber or in a semi-anechoic chamber. Alternatively, it may be tested in a semi-anechoic chamber or in an open space⁴. In ~~this~~ these cases, precautions

Comment [A18]: France GRB-62-20. The publication year of the standard is corrected to 2013.

Comment [B19]: The square brackets in the measurement accuracy values are now removed.

⁴ ~~The~~ The site may take the form, for instance, of an open space of 50 metres radius, the central part of which must be practically horizontal over a radius of at least 20 meters, the surface being of concrete, asphalt or a similar material, which must not be covered with powdery snow, tall weeds, or loose soil or cinders, as mentioned in ISO 10844:2014. The measurements shall be made on a clear day. No-one other than the observer reading the instrument shall remain near the audible warning device or the microphone, since the presence of spectators may affect the readings of the instrument to a considerable extent, if they are near the audible warning device or the microphone. Any peak which appears to be unrelated to the general sound level shall be disregarded in the reading.

shall be taken to avoid reflections from the ground within the measuring area (for instance by erecting a set of absorbing screens). ~~Compliance with the spherical divergence to a limit of 1 dB within a hemisphere of not less than 5 m radius, up to the maximum frequency to be measured, especially in the measuring direction and at the height of the apparatus and the microphone, shall be checked.~~ The wind speed shall be not more than 5 m/s. The ambient noise level shall be at least 10 dB lower than the sound pressure level to be measured.

~~The test facility in anechoic environment and semi-anechoic chambers shall meet requirements of Annex 3 or, alternatively, ISO 26101:2012, with the following qualification criteria and measurement requirements appropriate to this test method. For qualifying the acoustic space, the following evaluation shall be conducted:~~

- ~~• Sound source location shall be placed in position of the audible warning device to be tested;~~
- ~~• Sound source shall provide a broadband input for measurement;~~
- ~~• Evaluation shall be conducted in one-third octave bands;~~
- ~~• Microphone locations for evaluation shall be on a line from the source location to position of the microphone used for measurement. This is commonly referred to as the microphone transverse;~~
- ~~• A minimum of 10 points shall be used for evaluation on the microphone transverse line;~~
- ~~• The one-third octave bands used to establish hemi-anechoic qualification shall be defined to cover the spectral range of interest.~~

~~The test facility shall have a cut-off frequency, as defined in ISO 26101:2012, lower than the lowest frequency of interest. The lowest frequency of interest is the frequency below which there is no signal content relevant to the measurement of sound emission for the audible warning device. For the purpose of this Regulation the lowest frequency of interest is 200 Hz.~~

6.3.2.

The audible warning device, audible warning system or multiple audible warning system to be tested and the microphone shall be placed at the same height. This height shall be between 1.15 and 1.25 1.20 ± 0.05 m.

~~In alternative, the audible warning device, audible warning system or multiple audible warning system to be tested and the microphone may be placed in another *traverse* line which complies with annex 3 specification for anechoic environment.~~

The axis of maximum sensitivity of the microphone shall coincide with the direction of the maximum sound level of the audible warning device, audible warning system or multiple audible warning system.

The microphone shall be so placed that its diaphragm is at a distance of 2.00 ± 0.04 0.05 m from the plane of the sound outlet of the audible warning device. The microphone must be positioned facing the front surface emitting sound of the audible warning device, audible warning system or multiple audible warning system in the direction in which the maximum sound level can be measured. See figure in Annex 4.

Comment [B20]: Joint proposal by Japan and France as of May 2016. Reference to ISO 10844:2014 was modified by the Russian Federation.

Comment [A21]: Added in response to India comment in GRB-62-18.

Comment [B22]: Joint proposal by Japan and France as of May 2016.

Comment [A23]: France GRB-62-20, modified. It is proposed to set the exact value of the frequency of interest, which is estimated as 200 Hz because the lowest frequency of audible warning device, as a rule, is about 300 Hz and measurements are taken at frequency about 1500 Hz. If no exact value of the frequency of interest is provided, that frequency should be found out at every new test. Following the proposal by Japan the text was moved to Annex 3.

Comment [A24]: France in GRB-62-20 proposed to delete this text. Russian experts disagree with that as at this height the microphone can be conveniently positioned. Other locations of microphone are possible but not reasonable.

Comment [B25]: Joint proposal by Japan and France as of May 2016.

In the case of audible warning devices with several outlets, the distance shall be determined in relation to the plane of the nearest outlet to the microphone.

~~6.2.6.~~ 6.3.3. The audible warning device, audible warning system or multiple audible warning system shall be mounted rigidly, by means of the equipment indicated by the manufacturer, on a support whose mass is at least ten times that of the audible warning device, audible warning system or multiple audible warning system under test and not less than 30 kg. In addition, arrangements must be made to ensure ensuring that reflexions reflections on the sides of the support and its own vibrations have no appreciable effect on the measuring results.

~~6.2.3.~~ 6.3.4. The AWD audible warning device, audible warning system or multiple audible warning system shall be supplied with current, as appropriate, at the following voltages:

~~6.2.3.16.3.4.1.~~ in the case of AWDs audible warning devices, audible warning system or multiple audible warning system supplied with direct current, at a voltage measured at the terminal of the electric power source of 13/12 of the rated voltage.

~~6.2.3.26.3.4.2.~~ in the case of AWDs audible warning devices, audible warning system or multiple audible warning system supplied with alternating current, the current shall be supplied by an electric generator of the type normally used with this type of AWD audible warning device, audible warning system or multiple audible warning system. The acoustic characteristics of the AWD audible warning device, audible warning system or multiple audible warning system shall be recorded for electric generator speeds corresponding to 50%, 75% and 100% of the maximum speed indicated by the manufacturer of the generator for continuous operation. During this test, no other electrical load shall be imposed on the electric generator. The endurance test described in paragraph ~~6.3~~ 6.4. shall be carried out at a speed indicated by the manufacturer of the equipment and selected from the above range."

~~6.2.4.6.3.5.~~ If a rectified current source is used for the test of an AWD audible warning device, audible warning system or multiple audible warning system supplied with direct current, the alternating component of the voltage measured at its terminals, when the warning devices are in operation, shall not be more than 0.1 Volt, peak to peak.

~~6.2.5.~~ 6.3.6. For AWDs audible warning devices, audible warning system or multiple audible warning system supplied with direct current, the resistance of the connecting leads, expressed in ohms, including terminals and contacts, shall be as close as possible to $(0,10/12) \times$ rated voltage in volt.

~~6.2.7.~~ 6.3.7. Under the conditions set forth above, the sound-pressure level weighted in accordance with curve A shall not exceed the following values:

(a) 115 dB(A) for AWDs audible warning devices or audible warning system, multiple audible warning system intended principally for motor cycles with a power less than or equal to 7 kW;

(b) 118 dB(A) for AWDs audible warning devices or audible warning system, multiple audible warning system intended principally for vehicles of categories M, and N, T and motor cycles with a power greater than 7 kW.

~~6.2.7.16.3.7.1.~~ In addition, the sound-pressure level in the frequency band 1,800 to 3,550 Hz shall be greater than that of any component of a frequency above 3,550 Hz and in any event equal to or greater than:

Comment [A26]: France in GRB-62-20 proposed to delete this text. Russian experts disagree with that as a support of higher mass cannot generate secondary sound oscillations. Provision of the exact value of mass of the support works for repeatability of results. Without such specification the provision "mounted rigidly" at the beginning of this paragraph is inconcrete.

(a) 95 dB(A) for **audible warning devices** ~~or audible warning system, multiple audible warning system~~ intended principally for motor cycles with a power less than or equal to 7 kW;

(b) 105 dB(A) for ~~AWDs~~ **audible warning devices** ~~or audible warning system, multiple audible warning system~~ intended principally for vehicles of categories M, ~~and N, T~~ and motor cycles with a power greater than 7 kW.

~~6.2.7.2.6.3.7.2.~~ ~~AWDs~~ **Audible warning devices, audible warning system or multiple audible warning system** meeting the sound characteristics mentioned in (b) may be used on the vehicles mentioned in (a).

~~6.3.11.6.3.7.3.~~ In the case of **multiple audible warning systems**, the values of **sound pressure level** shall be obtained when each of the constituent units is operated separately and when all the constituent units are operated simultaneously and in any case those values shall be within the limits as specified above.

~~6.2.8.6.3.8.~~ The specifications indicated above shall also be met by an **audible warning device, audible warning system or multiple audible warning system** subjected to the endurance test referred to in paragraph ~~6.3~~ **6.4.** below, with the supply voltage varying between 115% and 95% of its rated voltage for ~~AWDs~~ **audible warning devices, audible warning system or multiple audible warning system** supplied with direct current or, for ~~AWDs~~ **audible warning devices, audible warning system or multiple audible warning system** supplied with alternating current, between 50% and 100% of the maximum speed of the generator indicated by the manufacturer for continuous operation.

~~6.2.9.6.3.9.~~ The time lapse between the moment when the ~~device~~ **audible warning device, audible warning system, multiple audible warning system** is actuated and the moment when the sound reaches the minimum value prescribed in paragraph 6.2.7. above shall not exceed 0.2 second measured at an ambient temperature of 20 ± 5 °C. This provision is applicable, ~~inter alia~~ *inter alia*, to pneumatic or electro-pneumatic ~~warning devices~~ **audible warning device, audible warning system, multiple audible warning system**.

~~6.2.10.6.3.10.~~ Pneumatic or electro-pneumatic ~~warning devices~~ **audible warning device, audible warning system, multiple audible warning system** shall, when operating under the power supply conditions established ~~for the devices~~ by the manufacturers, satisfy the same acoustic requirements as are prescribed for electrically operated audible warning device, **audible warning system, multiple audible warning system**.

~~6.2.11.6.3.11.~~ In the case of ~~multiple tone devices~~ ~~audible warning systems in which each sound-emitting unit is capable of functioning~~ ~~can be operated independently or in case of multiple audible warning systems,~~ the minimum values of **sound pressure level** specified above shall be obtained when each of the constituent units is operated separately. ~~The maximum value of the overall sound pressure level shall not be exceeded when all the constituent units are operated simultaneously.~~

6.3.11. To confirm the rated frequency (or frequencies) of **audible warning device(s), audible warning system or multiple audible warning system** the tests to measure this parameter using a spectrum analyzer with a frequency resolution of at least 1 Hz shall be conducted. The measured frequency of the **audible warning devices, audible warning system or multiple audible warning system** may differ from the rated no more than 10%.

Comment [A27]: Outcome of the meeting of 10 June 2016

Comment [A28]: OICA GRB-62-21-Rev.1. The word "pressure" was added two times following the proposal by Japan. The paragraph was deleted by the Moscow meeting of 10 June 2016 due to introduction of paragraph 6.3.7.3.

~~6.3.~~ 6.4. Endurance test

~~6.3.1.~~ 6.4.1. The ~~AWD audible warning device, audible warning system or multiple audible warning system~~ shall be supplied with current at the rated voltage and with the connecting lead resistances specified in paragraphs ~~6.2.3.6.3.4.~~ to ~~6.2.5.6.3.6.~~ above, and operated respectively:

10,000 times for ~~AWDs audible warning devices, audible warning system or multiple audible warning system~~ intended principally for motor cycles with a power less than or equal to 7 kW

50,000 times for ~~AWDs audible warning devices, audible warning system or multiple audible warning system~~ intended principally for vehicles of categories M ~~and~~, N, T and motor cycles with a power greater than 7 kW, each time for one second followed by an interval of ~~four seconds~~ 4 s.

During the test, the ~~AWD audible warning device, audible warning system or multiple audible warning system~~ shall be ventilated by an air current having a speed of approximately 10 m/see, and the electro-pneumatic audible warning device, ~~audible warning system, multiple audible warning system~~ may be lubricated with the oil recommended by the manufacturer after every 10,000 times of operation.

~~6.3.2.~~ 6.4.2. If the test is made in an anechoic chamber, the chamber shall be large enough to ensure normal dispersal of the heat released by the ~~audible warning device, audible warning system or multiple audible warning system~~ during the test.

~~6.3.3.~~ 6.4.3. The ambient temperature in the testing room shall be between +15 and +30 °C inclusively.

~~6.3.4.~~ 6.4.4. If, after the ~~AWD audible warning device, audible warning system or multiple audible warning system~~ has been operated for half the number of times prescribed, the sound-level characteristics are no longer the same as before the test, the ~~AWD audible warning device, audible warning system or multiple audible warning system~~ may be adjusted. After being operated the prescribed number of times, and after further adjustment if necessary, the ~~AWD audible warning device, audible warning system or multiple audible warning system~~ must pass the test described in paragraph ~~6.2. 6.3.~~ above.

~~6.3.5.~~ For warning devices of the electro-pneumatic type, the device may be lubricated with the oil recommended by the manufacturer after every 10,000 times of operation.

Comment [A29]: The word "inclusively" was added in response to India comment in GRB-62-18

7. Modification and extension of approval of the type of the audible warning device, ~~audible warning system, multiple audible warning system~~ and extension of approval

7.1. Any ~~Every~~ modification of the type of the audible warning device, ~~audible warning system, multiple audible warning system~~ shall be notified to the ~~administrative department~~ Type Approval Authority which granted approval to ~~the that~~ type of the audible warning device, ~~audible warning system, multiple audible warning system.~~ This ~~department~~ Type Approval Authority may then:

7.1.1. either take the view that the modifications made are not likely to have any appreciable adverse effect;

Comment [A30]: The text of this paragraph was added to the end of paragraph 6.4.1. (new numbering)

- 7.1.2. or call for a new report from the ~~Technical s~~Service responsible for the tests.
- 7.2. ~~Notice of Communication on~~ confirmation of the approval, with particulars of the modifications, or of refusal of approval shall be communicated to the Parties to the Agreement applying this Regulation, in accordance with the procedure indicated in paragraph 5.4. above.
- 7.3. The ~~competent authority~~ **Type Approval Authority** issuing the extension of approval shall assign a series number to each communication form drawn up for such an extension.

8. Conformity of production

The conformity of production procedures shall comply with those set out in the Agreement, Appendix 2 (E/ECE/324- E/ECE/TRANS/505/Rev.2) with the following requirements:

- 8.1. ~~AWD Audible warning device (system), audible warning system or multiple audible warning system~~ approved under this Regulation shall be so manufactured as to conform to the type approved by meeting the requirements set forth in paragraph 6. above.
- 8.2. The authority which has granted type approval may at any time verify the conformity control methods applied in each production facility. The normal frequency of these verifications shall be once every two years.

9. Penalties for non-conformity of production

- 9.1. The approval granted to a type of ~~audible warning device, audible warning system, multiple audible warning system~~ pursuant to this Regulation may be withdrawn if the conditions set forth in paragraph 8.1. are not complied with or if the ~~audible warning device, audible warning system or multiple audible warning system~~ fails to pass the checks referred to in paragraph 8.2. above.
- 9.2. Should a Party to the Agreement applying this Regulation withdraw an approval which it has previously granted, it shall forthwith notify the other Contracting Parties applying this Regulation by means of a copy of the approval form bearing at the end in large letters the statement, signed and dated: "APPROVAL WITHDRAWN".

10. Production definitively discontinued

If the holder of an approval granted pursuant to this Regulation discontinues the production of the type of ~~audible warning device, audible warning system, multiple audible warning system~~ approved, he shall inform the authority which granted the approval. Upon receipt of the communication, this authority shall inform the other Parties to the Agreement applying this Regulation by means of a copy of the approval form bearing at the end in large letters the statement, signed and dated: "PRODUCTION DISCONTINUED".

II. Part II. Audible warning signals of motor vehicles

11. Definitions

For the purpose of this Regulation,

- 11.1. ~~"Approval of the motor vehicle"~~ **"Approval of the motor vehicle"** shall be understood to mean approval of a vehicle type with regard to its audible **warning** signal;
- 11.2. ~~"Vehicle type"~~ **"Vehicle type"** shall be understood to mean vehicles not essentially different from another with respect to such matters as:
- 11.2.1. the number and type(s) of **audible warning devices and/or audible warning systems, and/or multiple audible warning systems** fitted on the vehicle;
- 11.2.2. the mountings used to fit the **audible warning devices and/or audible warning systems and/or multiple audible warning systems** to the vehicle;
- 11.2.3. the position of the **audible warning devices and/or audible warning systems and/or multiple audible warning systems** on the vehicle;
- 11.2.4. the rigidity of the parts of the structure on which the **audible warning device(s) and/or audible warning system(s) and/or multiple audible warning system(s)** is (are) mounted;
- 11.2.5. the shape and materials of the bodywork at the front of the vehicle which might affect the level of the sound emitted by the warning device(s) **and/or audible warning system(s) and/or multiple audible warning system(s)** and have a masking effect.

Comment [A31]: OICA GRB-62-21-Rev.1

12. Application for approval

- 12.1. The application for approval of a vehicle type with regard to its audible **warning** signals shall be submitted by the vehicle manufacturer or by his duly accredited representative;
- 12.2. It shall be accompanied by a **duly filled technical information** document, **either in paper format in triplicate or alternatively upon agreement with the Type Approval Authority in electronic format. A model of the technical information document is shown in Annex 1B.**
- ~~12.2. It shall be accompanied by the following documents in triplicate giving the following particulars:~~
- ~~12.2.1. a description of the vehicle type with regard to the items mentioned in paragraph 11.2. above;~~
- ~~12.2.2. a list of the components required to identify the warning device(s) **(system)** that may be mounted on the vehicle;~~
- ~~12.2.3. Drawings indicating the position of the warning device **system(s)** on the vehicle and of its **(their)** mountings.~~
- 12.3. A vehicle representative of the vehicle type to be approved shall be submitted to the technical service responsible for the approval tests.

Comment [B32]: Combined text by OICA, Japan and Russian Federation.

Comment [B33]: The remaining text of the paragraph 12.2 was deleted as proposed by Japan.

13. Approval

- 13.1. If the vehicle type submitted for approval pursuant to this Regulation meets the

requirements of paragraphs ~~14. and 15.~~ below, approval for this vehicle type shall be granted.

- 13.2. An approval number shall be assigned to each type approved. Its first two digits (at present 00 for the Regulation in its original form) shall indicate the series of amendments incorporating the most recent major technical amendments made to the Regulation at the time of issue of the approval. The same Contracting Party may not assign this number to another vehicle type.
- 13.3. ~~Notice of~~ **Communication on** approval or extension or withdrawal of approval or production definitely discontinued of a vehicle type pursuant to this Regulation shall be communicated to the Parties to the Agreement applying this Regulation by means of a form conforming to the model in ~~Annex 21B~~ **Annex 21B** to the Regulation, ~~and of drawings (supplied by the applicant for approval) with maximum format A.4 (210 x 297 mm), or folded to this format, and on an appropriate scale.~~
- 13.4. On every vehicle which conforms to a vehicle type approved under this Regulation there shall be affixed conspicuously, in an easily accessible place indicated on the approval form, an international approval mark comprising:
- 13.4.1. A circle surrounding the letter "E" followed by the distinguishing number of the country which has granted approval⁵;
- 13.4.2. The number of this Regulation, **followed by the letter "R", a dash and the approval number** placed to the right of the circle prescribed in paragraph 13.4.1.
- 13.5. **If the vehicle conforms to a vehicle type approved, under one or more other Regulations annexed to the Agreement, in the country which has granted approval under this Regulation, the symbol prescribed in paragraph 13.4.2. need not be repeated; in such a case the regulation and approval numbers and the additional symbols of all the Regulations under which approval has been granted in the country which has granted approval under this Regulation shall be placed in vertical columns to the right of the symbol prescribed in paragraph 13.4.**
- 13.6. The approval mark must be clearly legible and indelible.
- 13.7. The approval mark shall be placed near the plate bearing the characteristics of the vehicle and may also be affixed to this plate.
- 13.8. Annex ~~32~~, Section II, to this Regulation gives an example of the arrangement of the approval mark.
- 13.9. ~~The competent authority~~ **Type Approval Authority** shall verify the existence of satisfactory arrangements for ensuring effective control of the conformity of production before type approval is granted.

14. Specifications

14.1. General specifications

⁵ The distinguishing numbers of the Contracting Parties to the 1958 Agreement are reproduced in Annex 3 to Consolidated Resolution on the Construction of Vehicles (R.E.3) (ECE/TRANS/WP.29/78/Rev.2 3).

14.1.1. The audible warning device(s) ~~(system)~~ and/or audible warning system and/or multiple audible warning system shall be so designed, constructed and assembled as to enable the vehicle, in normal use, despite the vibration to which it may be subjected, to comply with the provisions of this Regulation.

14.1.2. The audible warning device(s) ~~(system(s))~~ and/or audible warning system(s) and/or multiple audible warning system(s) and its (their) mounting elements to the vehicle shall be so designed, constructed and assembled as to be able to reasonably resist the corrosive phenomena to which it is exposed with regards to the conditions of use of the vehicle, including regional climate differences.

Comment [A34]: OICA GRB-62-21-Rev.1

14.2. Specifications regarding sound levels

14.2.1. The sound made by the audible warning device(s) and/or audible warning system(s) and/or multiple audible warning system(s) fitted to the vehicle type submitted for approval shall be measured by the methods described in Annex 3 in paragraph 14.3 of this Regulation;

~~14.8.~~ Measured under the conditions specified in paragraphs 14.2. to 14.7., the maximum sound pressure level (14.7.) of the audible signal tested shall be at least:

(a) equal to 83 dB(A) and not more than 112 dB(A) for the signals of motor cycles of a power less than or equal to 7 kW;

(b) equal to 93 dB(A) and at most 112 dB(A) for the signals of vehicles of categories M and N 1/ and motor cycles of a power greater than 7 kW."

~~14.8.~~14.2.2. Measured under the conditions specified in paragraphs 14.2. to 14.7. 14.3., the maximum sound pressure level (14.7.) of the audible warning signal tested shall be at least:

(a) equal to 83 dB (A) and not more than 112 dB (A) for the signals of motor cycles of a power less than or equal to 7 kW;

(b) equal to 87 dB (A) and at most 112 dB (A) for the signals of vehicles of categories M, and N, and T and motor cycles of a power greater than 7 kW."

14.2.3. The values measured in accordance with the provisions of paragraph 14.3 shall be entered in the test report and a communication corresponding to the model shown in Annex 21B.

14.3. Methods of measurement on stationary vehicle

14.3.1. The vehicle shall comply with the following specifications:

~~14.1.~~14.3.1.1. The audible warning device(s) ~~(system(s))~~ and/or audible warning system(s) and/or multiple audible warning system(s) fitted on the vehicle shall be of a type approved under this Regulation (Part I);

~~14.1.1.~~ Audible warning devices of Class II approved under this Regulation in its original form, and therefore not bearing the symbol II in their approval mark, may continue to be fitted to vehicle types submitted for approval pursuant to this Regulation.

~~14.2.~~14.3.1.2. The test voltage shall be as specified in paragraph ~~6.2.3.~~ 6.3.4. of the Regulation;

In case of audible warning device(s), audible warning system(s), multiple audible warning system(s) supplied with direct current, the test voltage shall be supplied by either:

- (a) the vehicle battery only; or
- (b) the vehicle battery with the vehicle engine warmed-up and at idle; or
- (c) with an external power source supply connected to ~~the audible warning device (system) terminal(s)~~ the audible warning device(s) and/or audible warning system(s) and/or multiple audible warning system(s);

~~14.3.~~14.3.2. The sound pressure level and other measurements shall be made according to the conditions specified in paragraph 6.2. of this Regulation.

~~14.4.~~14.3.3. The A-weighted sound pressure level emitted by the audible warning device(s) and/or audible warning system(s) and/or multiple audible warning system(s) fitted on the vehicle shall be measured at a distance of 7.00 ± 0.10 m in front of the vehicle (Annex 5), ~~which is the latter~~ being placed on an open site⁶, on ground as smooth as possible flat concrete or asphalt surface. ~~and, in case of devices supplied with direct current, with its engine stopped. The test voltage as specified in paragraph 6.2.3 6.3.4., shall be supplied by:~~

- ~~(a) the vehicle battery only; or~~
- ~~(b) the vehicle battery with the vehicle engine warmed up and at idle; or~~
- ~~(c) with an external power source supply connected to the AWD terminal(s);~~

~~14.5.~~ 14.3.4. The microphone of the measuring instrument shall be placed approximately (± 0.10 m) in the mean longitudinal plane of the vehicle;

~~14.6.~~ 14.3.5. Background noise and wind noise must be at least 10 dB (A) below the sound to be measured;

~~14.7.~~ 14.3.6. ~~The maximum sound pressure level shall be sought within the range of 0.5 and 1.5 m above the ground; The maximum sound-pressure level shall be sought within the range of 0.5 and 1.5 m above the ground, and the height, at which the maximum sound-pressure level was found has to be fixed for the purpose of taking the measurements prescribed below.~~

The sound pressure level shall be measured at that fixed height for a duration of at least 3 seconds. The final result shall be the maximum A-weighted sound pressure level of the reading period, rounded mathematically to the nearest integer.

15. Modification and extension of approval of the vehicle type

15.1. Every modification of the vehicle type shall be notified to the administrative department Type Approval Authority which granted approval to the vehicle

Comment [535]: Clarification proposed by Korea.

Comment [536]: The text is based on OICA proposal as in GRB-62-21-Rev.1. It is proposed at first to find a height, where the maximum sound pressure level was achieved. On the second stage the sound pressure level shall be measured at that fixed height.

Comment [537]: IMMA GRB-63-15

Comment [A38]: The text is based on OICA proposal as in GRB- OICA GRB-62-21-Rev.1. It is proposed at first to find a height, where the maximum sound pressure level was achieved. On the second stage the sound pressure level shall be measured at that fixed height.

⁶ See paragraph 6.3.1., footnote 3.

type. This department Type Approval Authority may then:

- 15.1.1. either take the view that the modifications made are not likely to have any appreciable adverse effect and that in any case the vehicle still meets the requirements; or
- 15.1.2. call for a new report from the Technical Service responsible for the tests.
- 15.2. ~~Notice of~~ **Communication on** confirmation of approval with particulars of the modifications, or of refusal of approval shall be communicated to the Parties to the Agreement applying this Regulation, in accordance with the procedure indicated in paragraph 13.3. above.
- 15.3. ~~The competent authority~~ **Type Approval Authority** issuing the extension of approval shall assign a series number to each communication form drawn up for such an extension.

16. Conformity of production

The conformity of production procedures shall comply with those set out in the Agreement, Appendix 2 (E/ECE/324-E/ECE/TRANS/505/Rev.2) with the following requirements:

- 16.1. A vehicle approved under this Regulation shall be so manufactured as to conform to the type approved by meeting the requirements set forth in paragraph 14. above.
- 16.2. ~~The authority~~ **Type Approval Authority** which has granted type approval may at any time verify the conformity control methods applied in each production facility. The normal frequency of these verifications shall be once every two years.

17. Penalties for non-conformity of production

- 17.1. The approval granted to a vehicle type pursuant to this Regulation may be withdrawn if the conditions set forth in paragraph 16.1. above are not complied with, or if the vehicle fails to pass the checks referred to in paragraph 16.2. above.
- 17.2. Should a Party to the Agreement applying this Regulation withdraw an approval which it has previously granted, it shall forthwith notify the other Contracting Parties applying this Regulation by means of a copy of the approval from bearing at the end in large letters the statement, signed and dated: "APPROVAL WITHDRAWN".

18. Production definitively discontinued

- 18.1. **If the holder of the approval completely ceases to manufacture a vehicle type approved in accordance with this Regulation, he shall so inform the authority which granted the approval. Upon receiving the relevant communication that authority shall inform thereof the other Parties to the 1958 Agreement applying this Regulation by means of a communication form conforming to the model in Annex 1B to this Regulation.**

18. 19. Names and addresses of Technical Services responsible for conducting approval tests and of Type Approval Authorities

~~The Parties to the Agreement applying this Regulation shall communicate to the United Nations Secretariat the names and addresses of the technical services responsible for approval tests and of the administrative departments which grant approval and to which forms certifying approval or refusal or withdrawal of approval, issued in other countries, are to be sent.~~

The Contracting Parties to the 1958 Agreement applying this Regulation shall communicate to the United Nations Secretariat the names and addresses of the Technical Services responsible for conducting approval tests and of the Type Approval Authorities which grant approval and to which forms certifying approval or extension or refusal or withdrawal of approval, issued in other countries, are to be sent.

Annex 1A

(Maximum format: A 4(210 x 297 mm))



~~Communication concerning the approval (or refusal or withdrawal of approval or production definitely discontinued) of a type of audible warning device for motor vehicles pursuant to Regulation No. 28~~

Communication

(maximum format: A4 (210 x 297 mm))

issued by:

Name of administration:

.....
.....
.....



concerning:⁸ Approval granted
Approval extended
Approval refused
Approval withdrawn
Production definitively discontinued

of a type of⁹

~~audible warning device(s)~~

audible warning system

multiple audible warning system

for motor vehicles pursuant to Regulation No. 28

⁷ Distinguishing number of the country which has granted/extended/refused/withdrawn approval (see approval provisions in the Regulation). The proportions and dimensions in accordance with Annex 32.

⁸ Delete (strike out) what does not apply.

⁹ Delete (strike out) what does not apply.

Approval No.: .002439¹⁰

Extension No.: 00

1. Trade name or mark
2. Type (electro pneumatic, electro magnetic with resonator disc, electromagnetic horn, etc .) indicating whether it is a single tone or multiple tone warning device
3. Manufacturer's name and address.....
4. If applicable, name and address of manufacturer's representative.....
5. Brief description of warning devices
6. Supply voltage(s) volts */.....
7. Rated operating pressure(s) kg/cm² */.....
8. Rated frequency (or frequencies) Hz */.....
9. Geometrical characteristics (internal length and diameter) of connecting line between compressor or control and the audible warning device.....
10. Submitted for approval on.....
11. Technical service responsible for conducting approval tests.....
12. Date of report issued by that service.....
13. Number of report issued by that service
14. Approval granted/refused */.....
15. Place.....
16. Date.....
17. Signature.....
18. The following documents bearing the approval number shown above are annexed to this communication:.....
- drawings, diagrams and plans of the warning device; ... photographs.
*/Strike out whatever does not apply.

SECTION I

- 0.1. Make (trade name (mark) of manufacturer) **of audible warning device:**
- 0.2. Type or commercial description **of audible warning device(s) :**
- 0.3. Means of identification of type if marked **on the audible warning device(s):** ¹¹

¹⁰ Example of Approval No and Extension No. The first two digits of the approval number indicate that Regulation No. 28 was in its original form.

- 0.3.1. Location of that marking:
- 0.4. Class ~~of audible warning device(s)~~:¹²
- 0.5. Company name and address of manufacturer:
- 0.6. Name and address of the manufacturer's representative (if any):
- 0.7. Names and address(es) of assembly plant(s):

Comment [B39]: New addition by the Russian Federation.

SECTION II

- 1. Additional information (where applicable): See Addendum
- 2. Technical service responsible for carrying out the tests:
- 3. Date of test report:
- 4. Number of test report:
- 5. Remarks (if any): See Addendum
- 6. Place:
- 7. Date:
- 8. Signature:
- 9. Reasons for Extensions:

Attachments:

Information package

Test report(s)

Addendum to the communication form No. 002439¹³, Extension No.: 00

- 1. Additional information
 - 1.1. Brief description ~~of audible warning device(s) a principle of operation: pneumatic, electro-pneumatic, electro-magnetic with resonator disc, electromagnetic horn, etc .)~~¹⁴ ~~indicating whether it is a single tone or multiple tone warning device~~

¹¹ If the means of identification of type contains characters not relevant to describe the type warning devices covered by the type-approval certificate such characters shall be represented in the documentation by the symbol: '?' (e.g. ABC??123??).

¹² As defined in the paragraph 2.34.2.

¹³ Example of Approval No and Extension No. The first two digits of the approval number indicate that Regulation No. 28 was in its original form.

¹⁴ Delete (strike out) what does not apply.

- 1.1.1. **In case of audible warning system, multiple audible warning system, number of devices;**
- 1.2. **Supply Rated voltage(s), V¹⁵**
- 1.3. **Rated operating pressure(s), MPa (kg/cm²)¹⁶**
- 1.4. **Rated frequency (or frequencies), Hz¹⁷**
- 1.5. **Geometrical characteristics (internal length and diameter) of connecting line between compressor or control and the audible warning device, ~~audible warning system or multiple audible warning system~~**
- 2. **Test results for each of two samples**
- 2.1. **A-weighted sound pressure level ~~of warning devices~~, dB ~~(sample 1 / sample 2)~~**
- 2.2. **A-weight sound pressure level ~~of warning devices~~ in the frequency band 1,800 to 3,550 Hz ~~(sample 1/sample 2)~~, dB ~~(sample 1 / sample 2)~~**
- 2.3. **Measuring rated frequency (or frequencies), Hz¹⁸ ~~(sample 1 / sample 2)~~**
- 2.4. **Endurance test: passed / not passed¹⁹**
- 3. **Remarks**

Annex 1A – Appendix 1

Technical Information Document for type approval of²⁰ ~~(an)~~ audible warning device(s) audible warning system multiple audible warning system for motor vehicles

Comment [540]: Proposal by Japan modified by the Russian Federation

- 0. **General**
- 0.1. **Make (trade name (mark) of manufacturer) ~~of audible warning device(s)~~
:**
- 0.2. **Type or commercial description ~~of audible warning device(s)~~:**
- 0.3. **Means of identification of type if marked ~~on the warning device(s)~~:**
- 0.3.1. **Location of that marking:**

¹⁵ Delete (strike out) what does not apply.

¹⁶ Delete (strike out) what does not apply.

¹⁷ Delete (strike out) what does not apply.

¹⁸ Delete (strike out) what does not apply.

¹⁹ Delete (strike out) what does not apply.

²⁰ Delete (strike out) what does not apply.

- 0.4. Class ~~of audible warning device(s)~~;
- 0.5. Company name and address of manufacturer:
- 0.6. Name and address of the manufacturer's representative (if any):
- 0.7. Names and address(es) of assembly plant(s):
1. General construction characteristics ~~of audible warning device(s)~~;
- 1.1. Brief description ~~of audible warning device(s) a principle of operation: pneumatic, electro-pneumatic, electro-magnetic with resonator disc, electromagnetic horn, etc.)²¹ indicating whether it is a single tone or multiple tone warning device;~~
- 1.2. ~~Supply~~ Rated voltage(s), V²²;
- 1.2.1. Type of electrical supply (direct or alternating current);
- 1.3. Rated operating pressure(s), MPa (kg/cm²)²³;
- 1.4. Rated frequency (or frequencies), Hz²⁴;
- 1.5. Outer shape of case;
- 1.6. Shape and dimensions of diaphragm(s);
- 1.7. Shape or kind of sound outlet(s);
- 1.8. Geometrical characteristics (internal length and diameter) of connecting line between compressor or control and the audible warning device, ~~audible warning system, or multiple audible warning system;~~
- 1.9. Photographs and/or drawings ~~of representative audible warning device(s)~~;
- 1.10. Drawings showing the place provided for the approval number in relation to the circle of the approval mark; the location and the appearance of trade name or mark of the manufacturer ~~of the audible warning device (system) and type or commercial description (if any)~~;
- 1.11. A list of the components used in production, duly identified, with an indication of the materials used;
- 1.12. Drawings ~~of the audible warning device~~ in cross section and of all the components used in production.
- 1.13. Shape and dimensions of rigid connections for audible warning system, multiple audible warning system.

Signed:

Position in company:

Comment [B41]: New addition by the Russian Federation.

Comment [B42]: Proposal by Japan modified by the Russian Federation.

Comment [B43]: Proposal by Japan.

Comment [B44]: Proposal by Japan modified by the Russian Federation.

²¹ Delete (strike out) what does not apply.

²² Delete (strike out) what does not apply.

²³ Delete (strike out) what does not apply.

²⁴ Delete (strike out) what does not apply.

Date:

Annex 1B

~~(Maximum format: A 4(210 x 297 mm))~~



~~Communication concerning the approval (or refusal or withdrawal of approval or production definitely discontinued) of a type of audible warning device for motor vehicles pursuant to Regulation No. 28~~

Communication

(maximum format: A4 (210 x 297 mm))

issued by:

Name of administration:

.....



concerning:²⁶ Approval granted
 Approval extended
 Approval refused
 Approval withdrawn
 Production definitively discontinued

of a vehicle type with regard to its audible signals pursuant to Regulation No. 28

Approval No.: .002439²⁷

Extension No.: 00

1. Trade name or mark of the vehicle.....

2. Vehicle type.....

²⁵ Distinguishing number of the country which has granted/extended/refused/withdrawn approval (see approval provisions in the Regulation). The proportions and dimensions in accordance with Annex 32.

²⁶ Delete (strike out) what does not apply.

²⁷ Example of Approval No and Extension No. The first two digits of the approval number indicate that Regulation No. 28 was in its original form.

3. ~~Manufacturer's name and address.....~~
4. ~~If applicable, name and address of manufacturer's representative.....~~
5. ~~Type(s) of warning device(s) */.....~~
6. ~~Power supply used: Vehicle battery only/Battery with vehicle engine at idle/External power supply**/.....~~
7. ~~Sound level values:.....~~
8. ~~Submitted for approval on.....~~
9. ~~Technical service responsible for approval tests.....~~
10. ~~Date of report issued by that service.....~~
11. ~~Number of report issued by that service.....~~
12. ~~Approval granted/refused */.....~~
13. ~~Place.....~~
14. ~~Date.....~~
15. ~~Signature.....~~
16. ~~The following documents are annexed to this communication: drawings of the mountings of the warning device(s), ... drawings and diagrams giving the mounting positions and characteristics of the parts of the structure on which the devices are fitted. ... over all views of the front of the vehicle and of the compartment in which the device is situated and description of the component materials.....~~

~~*/~~—Indicate the approval numbers. A list of documents contained in the approval file transmitted to the administrative service which has granted approval is annexed to this communication.

~~**/~~—Strike out what does not apply.

SECTION I

- 0.1. **Make (trade name of manufacturer of vehicle):**
- 0.2. **Type:**
- 0.3. **Means of identification of type if marked on the vehicle: ²⁸**
- 0.3.1. **Location of that marking:**
- 0.4. **Category of vehicle: ²⁹**
- 0.5. **Company name and address of manufacturer:**
- 0.6. **Names and address(es) of assembly plant(s):**
- 0.7. **Name and address of the manufacturer's representative (if any):**

²⁸ If the means of identification of type contains characters not relevant to describe the vehicle types covered by the type-approval certificate such characters shall be represented in the documentation by the symbol: '?' (e.g. ABC??123??).

²⁹ As defined in the R.E.3.

SECTION II

1. Additional information (where applicable): See Addendum
2. Technical service responsible for carrying out the tests:
3. Date of test report:
4. Number of test report:
5. Remarks (if any): See Addendum
6. Place:
7. Date:
8. Signature:
9. Reasons for Extensions:

Attachments:

Information package

Test report(s)

Addendum to the communication form No. 002439 ³⁰ . Extension No.: 00

1. Additional information
 - 1.1. Make (trade name (mark) of manufacturer) of audible warning device(s), audible warning system(s) ~~and/or~~ multiple audible warning system(s):
 - 1.2. Type or commercial description of audible warning device(s), audible warning system(s) ~~and/or~~ multiple audible warning system(s):
 - 1.3. Means of identification of type if marked on the audible warning device(s), audible warning system(s) ~~and/or~~ multiple audible warning system(s):³¹
 - 1.4. The approval number ~~and issuing authority~~ of audible warning device(s), audible warning system(s) and/or multiple audible warning system(s) ~~and issuing authority~~
2. Test results
 - 2.1. Power supply used: Vehicle battery only / Battery with vehicle engine at idle / External power supply³²

³⁰ Example of Approval No. and Extension No. The first two digits of the approval number indicate that Regulation No. 28 was in its original form.

³¹ If the means of identification of type contains characters not relevant to describe the type of audible warning device(s), audible warning system(s) ~~and/or~~ multiple audible warning system(s) covered by the type-approval certificate, such characters shall be represented in the documentation by the symbol: '?' (e.g. ABC??123??).

2.2. A-weighted sound pressure level: dB

3. Remarks

Annex 1B – Appendix 1

Technical Information Document for type approval of a vehicle with regard to its audible warning signals

Comment [545]: Proposal by Japan modified by the Russian Federation.

0. General
- 0.1. Make (trade name of manufacturer of vehicle):
- 0.2. Type:
- 0.3. Means of identification of type if marked on the vehicle:³³
- 0.3.1. Location of that marking:
- 0.4. Category of vehicle³⁴:
- 0.5. Company name and address of manufacturer:
- 0.6. Name and address of the manufacturer's representative (if any):
- 0.7. Name(s) and Address(es) of assembly plant(s):
- 0.8. Make (trade name (mark) of manufacturer) of audible warning device(s), audible warning system(s) ~~and/or~~ multiple audible warning system(s):
- 0.9. Type or commercial description of audible warning device(s), audible warning system(s) ~~and/or~~ multiple audible warning system(s):
- 0.10. Means of identification of type if marked on the audible warning device(s), audible warning system(s) ~~and/or~~ multiple audible warning system(s):³⁵
- 0.11. The approval number of audible warning device(s), audible warning system(s) ~~and/or~~ multiple audible warning system(s) ~~and-issuing authority~~:
- 0.12. ~~Supply Rated~~ voltage(s), V³⁶:
- 0.13. Type of electrical supply (direct or alternating current):
- 0.14. Rated operating pressure(s), MPa (kg/cm²):

³² Delete (strike out) what does not apply.

³³ If the means of identification of type contains characters not relevant to describe the vehicle types covered by the type-approval certificate such characters shall be represented in the documentation by the symbol: '?' (e.g. ABC??123??).

³⁴ As defined in the R.E.3.

³⁵ If the means of identification of type contains characters not relevant to describe the type audible warning device(s), audible warning system(s) and/or multiple audible warning system(s) covered by the type-approval certificate such characters shall be represented in the documentation by the symbol: '?' (e.g. ABC??123??).

³⁶ Delete (strike out) what does not apply.

1. General construction characteristics of the mountings of the audible warning device(s) on the vehicle
- 1.1. Photographs or drawings of a representative vehicle:
- 1.2. Drawings ~~and photographs~~ of the mountings and mounting position(s) of the audible warning device(s):
- 1.3. Description of the component materials in front of the audible warning device(s), **audible warning system(s), multiple audible warning system(s)**:
- 1.4. A list of the components used in production on which the audible warning device(s), **audible warning system(s), multiple audible warning system(s)** are fitted, duly identified, with indication of the materials used;
- 1.5. Detailed drawings of all the components on which the device(s) are fitted, used in production;
- ~~1.6. A copy of the communication on approval of the audible warning device(s) mounted on a vehicle, if available.~~

Signed:

Position in company:

Date:

Comment [546]: This addition was made in response to the proposal by Japan, as there is no provision in UN Regulation No. 28 that an audible warning device to be installed on a vehicle is itself a subject to type-approval.

Annex 2

Arrangement of the approval mark

I. Arrangement of the approval mark of the audible warning device, audible warning system, multiple audible warning system

(see paragraph 5.5. of this Regulation)

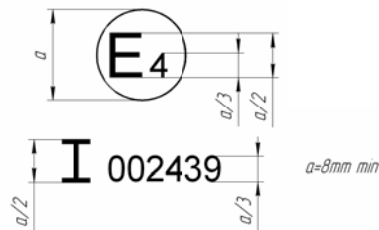

The above approval mark affixed to an audible warning device shows that this audible warning device of Class I has been approved in the Netherlands (E 4) under approval number 002439. The first two digits of the approval number indicate that the approval was granted in accordance with the requirements of Regulation No. 28 in its original form.

Notes:

1. The approval number must be placed close to the circle and must be in a position either above or below the letter "E" or to left or right of that letter. The digits of the approval number must be on the same side of the letter "E" and face in the same direction. The use of Roman numerals as approval numbers should be avoided so as to prevent any confusion with other symbols.

2. Approval marks of already existing types of audible warning devices (systems) or vehicle types may be continued to be used.

Comment [A47]: OICA GRB-62-21-Rev.1

II. Arrangement of the approval mark of vehicle with regard to its audible warning signals

(see paragraph 13.4. of this Regulation)

Model A

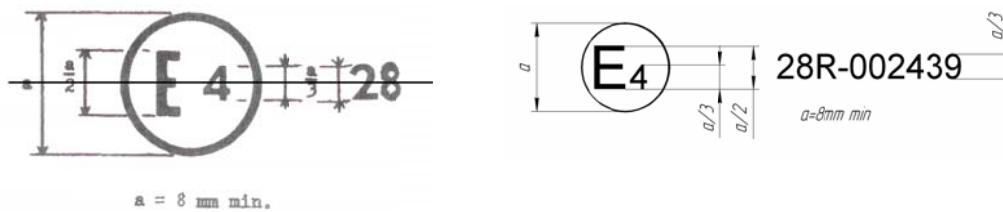

The above approval mark affixed to a vehicle indicates that, pursuant to Regulation No. 28, this vehicle type has been approved in the Netherlands (E 4), with regard to its audible warning signals. The first two digits of the approval number indicate that Regulation No. 28 was in its original form.

Model B

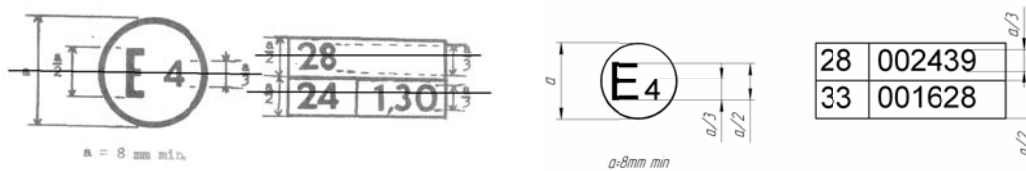

The above approval mark affixed to a vehicle indicates that, pursuant to Regulations Nos. 28 and 24 33, this vehicle type has been approved in the Netherlands (E 4), with regard to its audible signals and to emissions of pollutants by the Diesel engine. In the case of the latter Regulation, the corrected value of the absorption factor is 1.30 m^{-1} .

The above approval mark affixed to a vehicle shows that the vehicle type concerned has been approved in the Netherlands (E 4) pursuant to Regulations Nos. 28 and 33.³⁷ The approval numbers indicate that, at the dates when the respective approvals were granted, Regulation No. 28 and Regulation No. 33 were in their original form.

³⁷ The latter number is given as an example only.

Annex 3

Qualification criteria for anechoic environment

Comment [B48]: Joint proposal by Japan and France as of May 2016.

The anechoic environment shall meet the requirements of ISO 26101:2012 with the following qualification criteria and measurement requirements appropriate to this test method. For qualifying the acoustic space, the following evaluation shall be conducted:

- Sound source location shall be placed in position of the audible warning device, **audible warning system or multiple audible warning system** to be tested;
- Sound source shall provide a broadband input for measurement;
- Evaluation shall be conducted in one-third-octave bands;
- Microphone locations for evaluation shall be on a line from the source location to position of the microphone used for measurement. This is commonly referred to as the microphone traverse; only one microphone traverse line from the microphone to sound source shall be used
- A minimum of 10 points shall be used for evaluation on the microphone traverse line. The measurement shall start at $0,5 \pm 0,05$ m from the sound source, and spacing shall be ~~15 cm~~**0.15m** (e.g. ~~Figure~~ **Figure 1**).
- The one-third-octave bands used to establish anechoic qualification shall be defined to cover the spectral range of interest from 250 Hz to 10 kHz.
- The deviations of the measured sound pressure levels from those estimated using the inverse square law, shall not exceed the values given in the following table.

| One-third-octave-band frequency (Hz) | Allowable deviations (dB) |
|--------------------------------------|---------------------------|
| ≤ 630 | ± 1.5 |
| 800 to 5000 | ± 1.0 |
| ≥ 6300 | ± 1.5 |

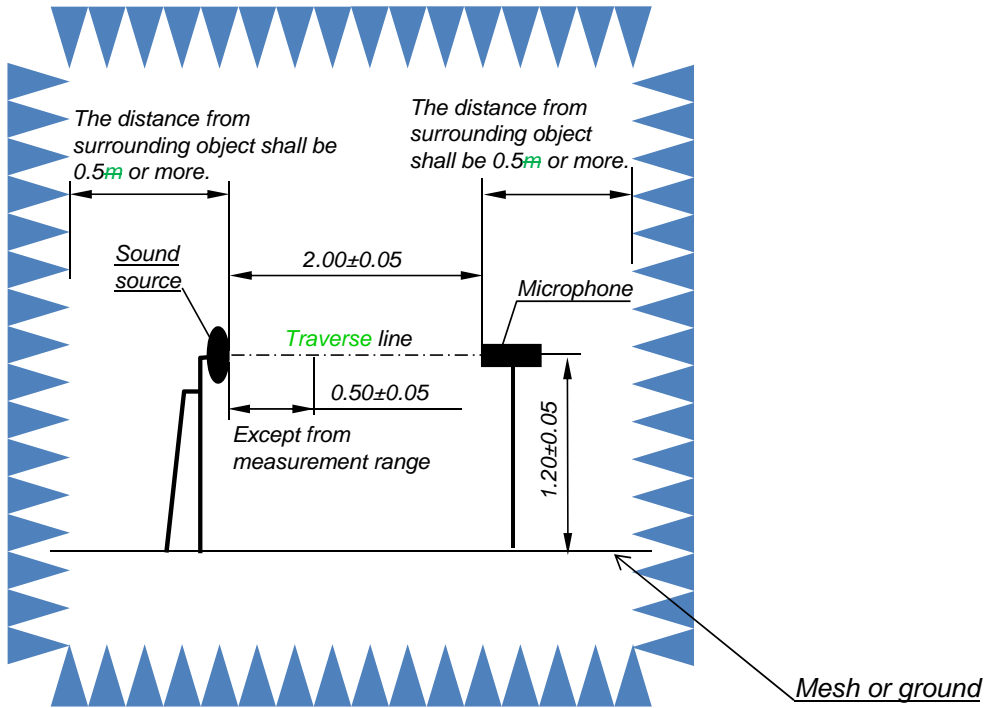

Figure 1 (All dimensions are in m)

Annex 4

Microphone positions for measurements of acoustics parameters of audible warning devices, **audible warning system, multiple audible warning system**

A. In case of an audible warning device

All dimensions are in m

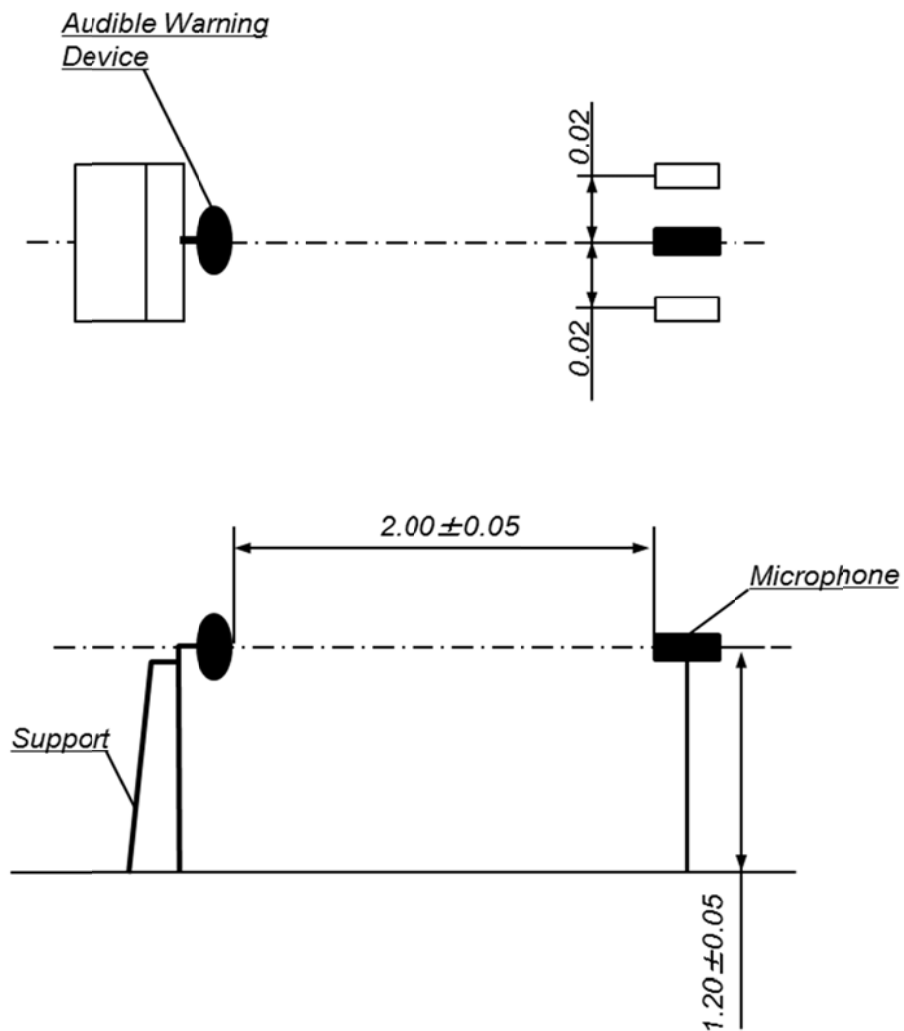

B. In case of audible warning system and multiple audible warning system

Comment [549]: Part B was added as proposed by Japan.

The reference point is the centre of a figure connecting the sound emitting opening centre of each audible warning device.

All dimensions are in m

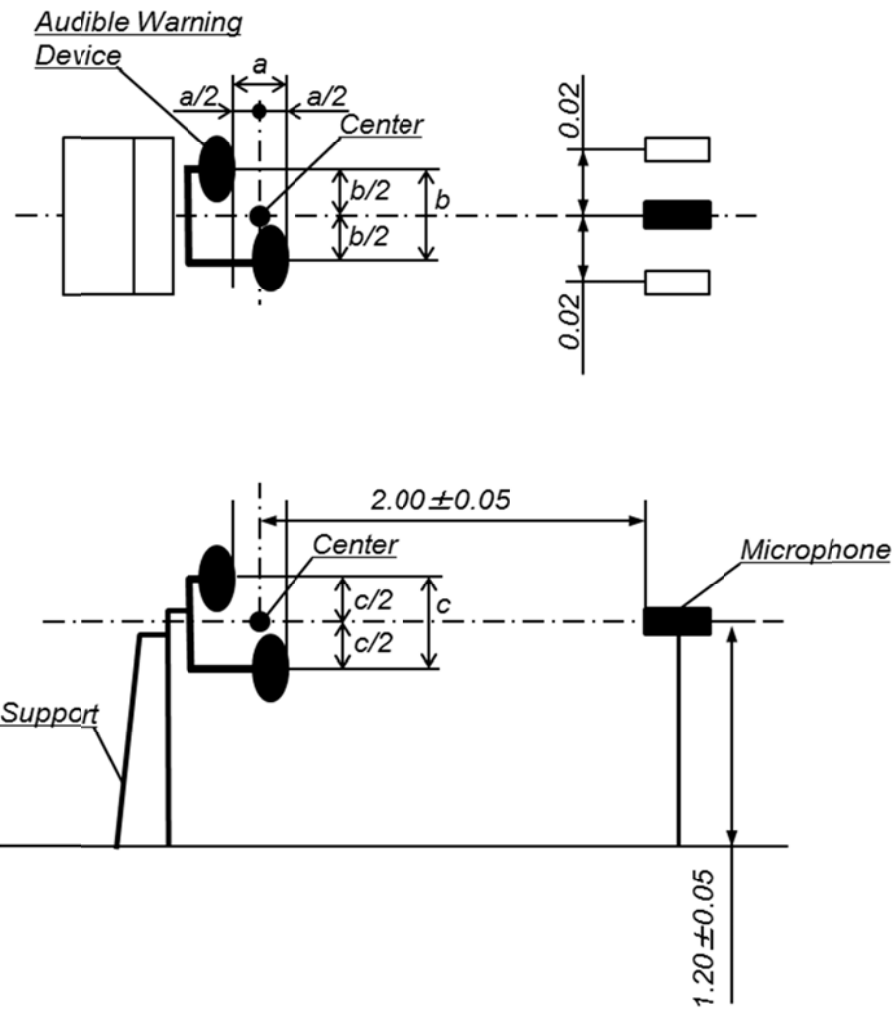

Annex 5

Microphone positions for measurements of audible warning signals of motor vehicles

Comment [B50]: The drawing changed to the one from GRB-63-04 (Russian Federation)

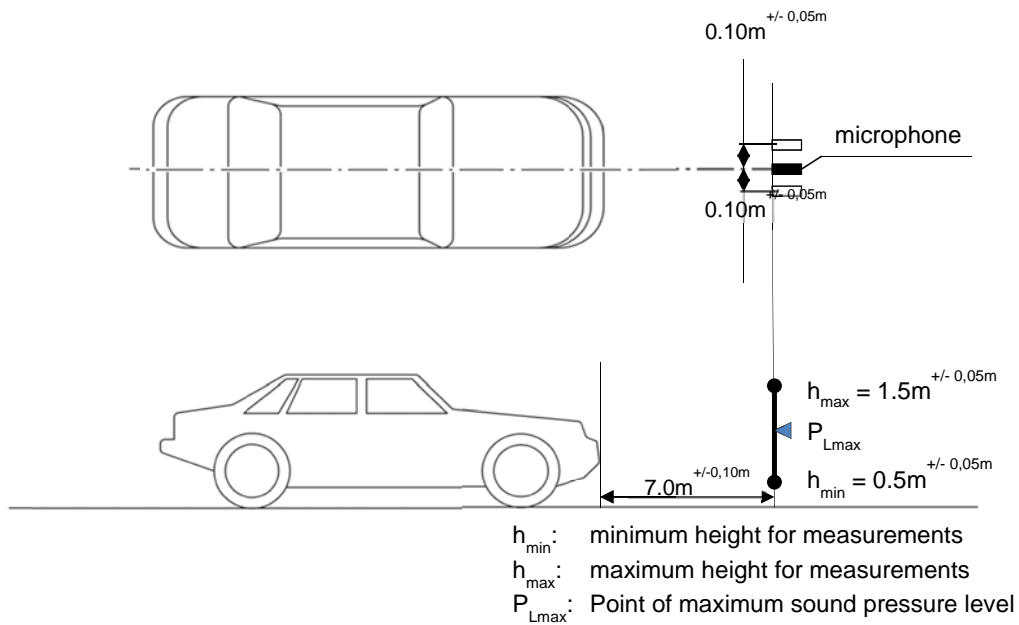

II. Justification

Contents

1. Sections 7, 10, 15, 19 reflect the change of headers. A new section 18 is added. New Annex 3 is added with qualification criteria for anechoic space. New Annexes 4 and 5 are added with graphical information.

Paragraph 1.

2. The text is modified in accordance with the present practice. It is proposed to extend the scope of the Regulation to vehicles of category T (agricultural and forestry tractors). It is also proposed not to refer to abbreviation "AWD" as it causes confusion, because AWD also stands for "all wheel drive".

3. Paragraph 1 was rearranged to allow further extension of this Regulation to other audible warning devices not yet regulated at UN level.

Paragraph 2.

4. The proposals give more clear definitions of audible warning devices.

Paragraph 3.

5. The improvements are made to the extent modified in paragraph 2 of the definition "system" of audible warning devices. The term "Competent authority" is replaced by the term "Type Approval Authority" (here and throughout the text of the Regulation).

Paragraph 4.

6. The text clarifies the requirements for the markings on the case of audible warning devices.

Paragraph 5.

7. Subject to editorial and clarification changes.

Paragraph 6.1.1.

8. The text provides for clarification on the number of tests.

Paragraph 6.2.1.

9. The proposal provides for clarification on the test procedure and the test site.

10. The proposal also specifies the requirements to devices for sound measuring as well as for other measuring devices.

Paragraph 6.2.2.

11. The accuracy provides for 10% relative error from the measured values.

Paragraph 6.3.1.

12. The reference to the requirements for anechoic and semi-anechoic chambers in Annex 3 is added.

Paragraph 6.3.2.

13. The text provides for clarification on the positioning of the measuring microphone during the tests. The reference to the Annex 4 is added.

Paragraph 6.3.7.1.

14. Sets the requirements for category T similar to those for the both categories M and N.

Paragraph 6.3.12.

15. As the rated frequency is mentioned in the communication on type approval, it is proposed to measure it. For CoP this provision is also applicable.

Paragraphs 13.4.2. and 13.5.

16. Specify the types of approval markings. The text is modified in accordance with the present practice.

Paragraph 14.1.

17. The proposal sets general requirements for vehicle audible warning device(s) reliability and provides for persistence of the performance, confirmed at the type approval process, without excessive degradation during the service life.

Paragraph 14.3.

18. The test procedure has been more specified to reduce existing uncertainties.

Paragraph 14.3.2.

19. The proposal clarifies the position of the measuring points.

Paragraph 14.3.6.

20. It is proposed at first to find a height, where the maximum sound pressure level was achieved. On the second stage the sound pressure level shall be measured at that fixed height.

Annexes 1A and 1B

21. The proposal refines the form of official communication on type approval. The Appendix 1 is added to each Annex with the requirements to the technical information document.

Annex 2

22. The text is modified in accordance with the present practice.
