



Economic and Social Council

Distr.: General
24 July 2013

Original: English

Economic Commission for Europe

Inland Transport Committee

World Forum for Harmonization of Vehicle Regulations

Working Party on General Safety Provisions

105th session

Geneva, 8–11 October 2013

Item 7 of the provisional agenda

Regulation No. 58 (Rear underrun protection)

Proposal for amendments to Regulation No. 58 (Rear underrun protection)

Submitted by the expert from Germany*

The text reproduced below was produced by the expert from Germany to introduce more stringent requirements for rear underrun protection devices. This proposal supersedes documents ECE/TRANS/WP.29/GRSG/2011/19 and GRSG-102-26. The modifications to the current text of the Regulation are marked in bold for new or strikethrough for deleted characters.

* In accordance with the programme of work of the Inland Transport Committee for 2010–2014 (ECE/TRANS/208, para. 106 and ECE/TRANS/2010/8, programme activity 02.4), the World Forum will develop, harmonize and update Regulations in order to enhance the performance of vehicles. The present document is submitted in conformity with that mandate.

I. Proposal

List of Annexes, insert a reference to new Annexes 6 and 7, to read:

- " 6 Type of vehicles for exemptions
 7 Requirements for different vehicle categories "

Paragraph 1.2.3., shall be deleted.

Insert new paragraphs 1.3. and 1.4., to read:

- "1.3. Subject to the decision of the Type Approval Authority, vehicles where any RUP is incompatible with their use can be exempted from this Regulation.
 1.4. Vehicles listed in Annex 6 are partially exempted from the maximum force levels requested by this Regulation."

Paragraph 2.3., amend to read:

- "2.3. Any vehicle ...
 (c) ... on either side, or
 (d) If, in case of vehicles of category G, the departure angle (ISO 612:1978) does not exceed 10° for vehicles of categories M₁G and N₁G, 20° for vehicles of categories M₂G and N₂G and 25° for vehicles of categories M₃G and N₃G over a width which is not shorter than that of the rear axle by more than 100 mm on either side (excluding any tyre bulging close to the ground).

Where there ..."

Paragraph 6.2., amend to read:

- "6.2. An approval number shall be assigned to each type approved. Its first two digits (at present 02 03 corresponding to the 02 03 series of amendments) shall indicate the series of amendments incorporating ..."

Paragraphs 7.1. and 7.2., amend to read:

- "7.1. ~~The section height of the cross member must not be less than 100 mm. The cross-member shall have a section height of at least 120 mm.~~ The lateral extremities of the cross-member ~~must shall~~ not bend ... less than 2.5 mm.

For vehicles of categories M₁, M₂, M₃, N₁, N₂, O₁, O₂, vehicles of category G and vehicles fitted with a platform lift the cross-member shall have a section height of at least 100 mm.

- 7.2. The RUPD may be so designed to have several positions at the rear of the vehicle. In this event, there ~~shall must~~ be a ... operator to vary the position of the device ~~shall must~~ not exceed 40 daN.

For RUPD that are designed to have several positions at the rear of the vehicle, a label shall be provided in the language(s) of the country where the device is sold.

Label minimum size: 60 x 120 mm

The label shall be placed clearly and permanently visible at the rear of the vehicle next to the RUPD to inform the operator about the standard position of the RUPD to offer effective protection against under-running."

Paragraph 7.4.2., amend to read:

"7.4.2. The individual elements of the under run protection, including those outboard of the lift mechanism, where provided, ~~must~~ shall have an effective surface area, in each case, of at least ~~350~~ 420 cm². **For cross-members with a section height of less than 120 mm, the effective surface area shall have at least 350 cm².**

However, ..."

Paragraph 15.2., amend to read:

"15.2. An approval number shall be assigned to each type approved. Its first two digits (at present 02 03 corresponding to the 02 03 series of amendments) shall indicate the series of amendments incorporating ..."

Insert a new paragraph 16.1., to read:

"16.1. **For vehicles of the categories N₂, N₃, O₃ and O₄ the ground clearance with respect to the underside of the protective device, even when the vehicle is unladen, shall not exceed:**

- (a) **450 mm for motor vehicles and trailers with hydropneumatic, hydraulic or pneumatic suspension or a device for automatic leveling according to load; and**
- (b) **500 mm for vehicles other than those in (a) above.**

This requirement applies over the entire width of the motor vehicle or trailer and shall be such that the height above the ground of the points of application of the test forces applied to the device according to Part I of this Regulation and recorded in the type approval communication form (Annex 1, item 7) does not exceed:

- (a) **510 mm for motor vehicles and trailers with hydropneumatic, hydraulic or pneumatic suspension or with a device for automatic leveling according to load; and**
- (b) **560 mm for vehicles other than those listed in subparagraph (a) above.**

The height above the ground of the points of application of the test forces is depending of the section height of the cross-member and in any case the test forces shall be applied at the height of the horizontal centre line of the cross-member."

Paragraph 16.1. (former), renumber as paragraph 16.2. and amend to read:

"~~16.1.~~16.2. **For vehicles of categories M₁, M₂, M₃, N₁, O₁ and O₂, The** the ground clearance with respect to the underside of the protective device ..."

Paragraphs 16.2. (former), renumber as paragraph 16.3.

Paragraph 16.3. (former), renumber as paragraph 16.4. and amend to read:

"~~16.3.~~16.4. The device ~~must~~ shall be so fitted that the horizontal distance between the rear of the **cross-member of the device** and the **most rearward point at the rear extremity of the vehicle**, including any platform lift system ~~mechanism~~, does not exceed **300 mm measured at the point of the maximum section height of the cross-member according to paragraph 7.1.** and 400 mm diminished by the recorded deformation ... unladen shall be excluded.

For vehicles of categories O₃ and O₄, without any platform lift system and not being designed as a tipping-trailer, the maximum horizontal

distances are reduced to 200 mm before and 300 mm after the test forces have been applied.

Before the application of the test forces the maximum allowed horizontal distance of a single, a segmented or an inclined cross-member of a RUPD is 100 mm between the rear of the cross-member measured at the most forward point and the rear of the cross-member measured at the most rearward point, measured in the longitudinal plane of the vehicle."

Insert a new paragraph 16.5., to read:

"16.5. After the application of the test forces specified in Annex 5 for vehicles of the categories N₂, N₃, O₃ and O₄, the maximum ground clearance of the protective device, even when the vehicle is unladen, shall at any point not exceed:

- (a) 510 mm for motor vehicles and trailers with hydropneumatic, hydraulic or pneumatic suspension or with a device for automatic levelling according to load, and
- (b) 560 mm for vehicles other than those listed in subparagraph (a) above."

Paragraph 16.4. (former), renumber as paragraph 16.6.

Paragraph 24.2., amend to read:

"24.2. An approval number shall be assigned to each type approved. Its first two digits (at present 02 03 corresponding to the 02 03 series of amendments) shall indicate the series of amendments ..."

Paragraph 25.1., amend to read:

"25.1. For vehicles of the categories N₂, N₃, O₃ and O₄ the ground clearance with respect to the underside of the RUP, even when the vehicle is unladen, ~~must not exceed 550 mm over its entire width~~ shall not exceed:

- (a) 450 mm for motor vehicles and trailers with hydropneumatic, hydraulic or pneumatic suspension or with a device for automatic leveling according to load, and
- (b) 500 mm for vehicles other than those listed in subparagraph (a) above.

This requirement applies over the entire width of the motor vehicle or trailer and shall be such that the height above the ground of the points of application of the test forces applied to the device according to Part I of this Regulation and recorded in the type approval communication form (Annex 1, item 7) does not exceed:

- (a) 510 mm for motor vehicles and trailers with hydropneumatic, hydraulic or pneumatic suspension or with a device for automatic leveling according to load, and
- (b) 560 mm for vehicles other than those listed in subparagraph (a) above.

The height above the ground of the points of application of the test forces is depending of the section height of the cross-member and in any case the test forces shall be applied at the height of the horizontal centre line of the cross-member."

Insert a new paragraph 25.2., to read:

"25.2. For vehicles of categories M₁, M₂, M₃, N₁, O₁ and O₂, the ground clearance with respect to the underside of the protective device, even when the vehicle is unladen, shall not exceed 550 mm over its entire width and shall be such that the height above the ground of the points of application of the test forces applied to the device according to Part I of this Regulation and recorded in the type approval communication form (Annex 1, item 7) does not exceed 600 mm."

Paragraph 25.2. (former), renumber as paragraph 25.3. and amend to read:

"25.23. The RUP ~~must~~ shall be situated as close to the rear of the vehicle as possible. The maximum horizontal distance between the rear of the device and the most rearward point at the rear extremity of the vehicle, including any platform lift system, does not exceed 300 mm measured at the point of the maximum section height of the cross-member according to paragraph 25.4.

For RUP for vehicles of categories O₃ and O₄, without any platform lift system and not being designed as a tipping-trailer, the maximum horizontal distance is reduced to 200 mm."

Paragraph 25.3. (former), renumber as paragraph 25.4.

Paragraph 25.4. to 25.6. (former), renumber as paragraphs 25.5. to 25.7. and amend to read:

"25.45. ~~The section height of the RUP must not be less than 100 mm.~~ The cross-member shall have a section height of at least 120 mm. The lateral extremities of the cross-member ~~must~~ shall not bend ... than 2.5 mm.

For vehicles of the categories M₁, M₂, M₃, N₁, N₂, O₁, O₂, vehicles of category G and vehicles fitted with a platform lift the cross-member shall have a section height of at least 100 mm.

25.56. The RUP may be so designed to have several positions at the rear of the vehicle. In this event, there ~~must~~ shall be ... position of the RUP ~~must~~ shall not exceed 40 daN.

For RUPD that are designed to have several positions at the rear of the vehicle a label shall be provided in the language(s) of the country where the device is sold.

Label minimum size: 60 x 120 mm

The label shall be placed clearly and permanently visible at the rear of the vehicle next to the RUPD to inform the operator about the standard position of the RUPD to offer effective protection against under-running."

25.67. The RUP ~~must~~ shall offer ... RUP and the most rearward point at the rear extremity of the vehicle, including any platform lift ~~system mechanism~~, does not exceed ... more than 2 m above the ground ~~when the vehicle is unladen~~ ~~must~~ for every loading condition of the vehicle shall be excluded.

After applying the test forces specified in Annex 5 for vehicles of the categories N₂, N₃, O₃ and O₄, the maximum ground clearance of the protective device, even when the vehicle is unladen, shall at any point not exceed:

- (a) **510 mm for motor vehicles and trailers with hydropneumatic, hydraulic or pneumatic suspension or with a device for automatic levelling according to load; and**
- (b) **560 mm for vehicles other than those listed in subparagraph (a) above."**

Paragraphs 25.7 and 25.8.1. (former), renumber as paragraphs 25.8 and 25.9.1.

Paragraph 25.8.2. (former), renumber as paragraph 25.9.2. and amend to read:

"25.89.2. The individual elements of the underrun protection, including those outboard of the lift ~~system mechanism~~, where provided, ~~must~~ **shall** have an effective surface area, in each case, of **at least 420 cm². For cross-members with a section height of less than 120 mm the effective surface area shall have at least 350 cm².**

However, ..."

Paragraphs 31.1. to 31.5., amend to read:

- "31.1. As from the official date of entry into force of the ~~02~~ **03** series of amendments, no Contracting Party applying this Regulation ~~shall~~:
 - (a) **Shall** refuse ... as amended by the ~~02~~ **03** series of amendments;
 - (b) **Shall** refuse ... as amended by the ~~02~~ **03** series of amendments;
 - (c) **May** prohibit ... as amended by the ~~02~~ **03** series of amendments.
- 31.2. Until ~~18~~ **24** months after the date of entry into force of this Regulation as amended by the ~~02~~ **03** series of amendments, Contracting Parties applying this Regulation shall:
 - (a) ... as amended by the ~~04~~ **02** series of amendments;
 - (b) ... as amended by the ~~04~~ **02** series of amendments;
 - (c) ... as amended by the ~~04~~ **02** series of amendments;
 - (d) ... as amended by the ~~04~~ **02** series of amendments.
- 31.3. Starting ~~18~~ **24** months after the date of entry into force of this Regulation as amended by the ~~02~~ **03** series of amendments, Contracting Parties applying this Regulation:
 - (a) May refuse ... as amended by the ~~02~~ **03** series of amendments;
 - (b) Shall grant ... as amended by the ~~02~~ **03** series of amendments;
 - (c) May prohibit ... as amended by the ~~02~~ **03** series of amendments.
- 31.4. Until 48 months following the date of entry into force of this Regulation as amended by the ~~02~~ **03** series of amendments Contracting Parties applying this Regulation shall:
 - (a) Continue to grant ... as amended by the ~~04~~ **02** series of amendments;
 - (b) Continue to accept ... as amended by the ~~04~~ **02** series of amendments.
- 31.5. As from 48 months after the date of entry into force of this Regulation as amended by the ~~02~~ **03** series of amendments, Contracting Parties applying this Regulation:
 - (a) Shall grant ... as amended by the ~~02~~ **03** series of amendments;

- (b) May refuse national ... as amended by the 02 03 series of amendments."

Annex 5,

Paragraph 1.1.3., amend to read:

- "1.1.3. On a rigid test bench (see Figure 1, representing the minimum requirements to be fulfilled).

Figure 1

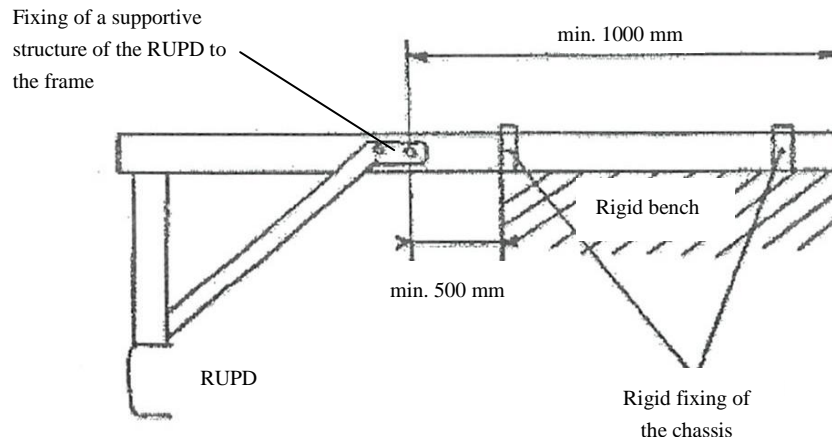

Insert new paragraph 1.4., to read:

- "1.4. In the case of a RUPD where the cross-member does not have a vertical flat surface of at least 50 per cent of the minimum section height of the cross-member according to paragraph 7.1. or 25.5. of this Regulation at the height of the points of application of the test forces according to paragraph 16.1. or 25.1., the manufacturer shall supply the Technical Service with a device that allows the application of horizontal test loads on the cross-member with the test equipment used by the Technical Service."

Paragraphs 3.1. to 3.1.3., amend to read:

- "3.1. The requirements of paragraphs 7.3. and 25.7.6 of this Regulation ... in height (the exact height ~~must~~ shall be indicated by ... the centre of the surface ~~must~~ shall be defined by ... on a vehicle the height ~~must~~ shall not, however, exceed ~~600 mm~~ the height as specified in paragraphs 16.1. and 16.2. or as specified in paragraphs 25.1. and 25.2. of this Regulation when the vehicle is unladen. The order in which the forces are applied may be specified by the manufacturer.
- 3.1.1. A horizontal force of ~~100~~ 180 kN or ~~50~~ 85 per cent of the force ... by the manufacturer.
- 3.1.2. In the cases defined in paragraphs 1.1.1. and 1.1.2. of this annex a horizontal force of ~~50~~ 100 kN or ~~25~~ 50 per cent of the force ... plane of the vehicle.
- 3.1.3. In the cases defined in paragraph 1.1.3. of this annex a horizontal force of ~~50~~ 100 kN or ~~25~~ 50 per cent of the force ... plane of the device."

Insert a new paragraph 3.1.4., to read:

- "3.1.4. On request of the manufacturer the force levels can be reduced to [80] per cent of the requirement given in paragraphs 3.1.1. to 3.1.3. of this annex for the vehicles listed in paragraphs 1.1. to 1.5. of Annex 6."**

Insert a new Annex 6, to read:

"Annex 6

Type of vehicles for exemptions

1. List of vehicles:
 - 1.1. Motor vehicles with a horizontal distance of less than [750] mm from the centre of the most rearward axle to the rear extremity of the vehicle;
 - 1.2. Dump-trucks that are equipped with a foldable RUPD;
 - 1.3. Tipping-trailers;
 - 1.4. Vehicles fitted with a platform lift at the rear;
 - 1.5. Vehicles fitted with a longitudinally adjustable RUPD."

Insert a new Annex 7, to read:

"Annex 7

Requirements for different vehicle categories

Vehicle category or type of vehicle	Geometry referred to in paragraph:			Test force referred to in paragraph:
	Section height	Ground clearance:	Horizontal distance between the rear of the RUPD and the rear of the vehicle:	
M ₁ , M ₂ , M ₃ , N ₁ , O ₁ , O ₂ , G	2.3.	2.3.	2.3.	2.3.
N ₂ , N ₃	7.1. or 25.5.	16.1./16.2. or 25.1./25.2.	16.4. or 25.3.	A5/3.1.1. to 3.1.3.
O ₃ , O ₄	7.1. or 25.5.	16.1./16.2. or 25.1./25.2.	16.4. or 25.3.	A5/3.1.1. to 3.1.3.
Specific Vehicles (see Annex 6)	7.1. or 25.5.	16.1./16.2. or 25.1./25.2.	16.4. or 25.3.	A5/3.1.4.

Note: A reference such as A5/3.1.1 in the table indicates the annex (Annex 5) and paragraph (3.1.1.) of that annex, where the relevant vehicle or requirement is described and specified. A reference such as 2.3 in the table indicates paragraph (2.3.) of this Regulation, where the relevant requirement is specified."

II. Justification

A detailed justification will be provided in an informal document.