

**Economic and Social Council**Distr.: General
18 June 2012

Original: English

Economic Commission for Europe**Inland Transport Committee****World Forum for Harmonization of Vehicle Regulations****Working Party on Noise****Fifty-sixth session**

Geneva, 3–5 September 2012

Item 2 of the provisional agenda

Regulation No. 41 (Noise of motorcycles)**Proposal for Supplement 1 to the 04 series of amendments to Regulation No. 41****Submitted by the expert from the Russian Federation***

The text reproduced below was prepared by the expert from the Russian Federation as agreed during the fifty-fifth session of the Working Party on Noise (GRB) (see ECE/TRANS/WP.29/GRE/53, para. 3) to provide harmonized definitions on vehicle type concerning noise, terms "noise" and "sound" and also a revised structure of introducing the provisions. It is based on a document distributed without symbol (GRB-55-08) at that session. The modifications to the current text of the Regulation are shown in bold characters for new or strikethrough for deleted characters.

* In accordance with the programme of work of the Inland Transport Committee for 2010–2014 (ECE/TRANS/2010/8, programme activity 02.4), the World Forum will develop, harmonize and update Regulations in order to enhance the performance of vehicles. The present document is submitted in conformity with that mandate.

I. Proposal

Paragraph 1., amend to read:

- "1. This Regulation applies to **motorcycles** (vehicles of category L₃¹) with regard to noise."

Paragraph 2.2., amend to read:

- "2.2. ~~"Type of motor cycle as regards its noise emissions sound level and exhaust system"~~ means motor cycles which do not differ in such essential respects as the following:"

Paragraph 2.2.3., amend to read:

- "2.2.3. Number, type and arrangement of ~~exhaust or silencing systems~~ **noise reduction systems.**"

Paragraph 2.3., amend to read:

- "2.3. ~~"Exhaust or silencing system"~~ **"Noise reduction system"** means a complete set of components necessary to limit the noise caused by a motor cycle engine ~~and~~, its exhaust **and intake.**"

Paragraph 2.3.1., amend to read:

- "2.3.1. ~~"Original exhaust or silencing system"~~ **"Original noise reduction system"** means a system of a type fitted to the ~~vehicle~~ **motorcycle** at the time of type approval or extension of type approval. ~~It may also be the vehicle manufacturer's replacement part.~~

Paragraph 2.3.2., to be deleted.

Paragraph 2.4., amend to read:

- "2.4. ~~"Exhaust or silencing systems"~~ **noise reduction systems of differing types** means systems which are fundamentally different in one of the following ways:"

Paragraph 2.5., amend to read:

- "2.5. ~~"Component of an exhaust or silencing system"~~ **noise reduction system** means one of the individual components which together form the exhaust system (such as exhaust pipework, the silencer proper, **catalyst**), the intake system (air filter, **resonator, intake silencer**) ~~if any~~ **and elements of a soundproofing capsule (shield).**

~~If the engine has to be equipped with an intake system (air filter and/or intake noise absorber) in order to comply with the maximum permissible sound levels, the filter and/or absorber shall be treated as components having the same importance as the exhaust system."~~

Paragraph 2.6., and below, for "vehicle(s)" read: "motor cycle(s)"

¹ As defined in the Consolidated resolution on the Construction of vehicles (R.E.3), **document ECE/TRANS/WP.29/78/Rev.2, para.2.**

Paragraph 2.9., amend to read:

"2.9. "Power-to-mass ratio index" means the ratio of the rated maximum net power of a ~~vehicle~~ **motor cycle engine** to ~~its~~ **the motor cycle kerb mass plus 75 kg**. It is defined as: ..."

Paragraph 3.1., amend to read:

"3.1. The application for approval of a motor cycle type with regard to its ~~sound~~ **noise** emissions shall be submitted by its manufacturer or by his duly accredited representative."

Paragraph 3.2.2., amend to read:

"3.2.2. A list of the components, duly identified, constituting the ~~exhaust or silencing~~ **noise reduction** system."

Paragraph 3.2.3., amend to read:

"3.2.3. A drawing of the assembled ~~exhaust or silencing~~ **noise reduction** system and an indication of its position on the motor cycle;"

Paragraph 3.2.4., amend to read:

"3.2.4. Drawings of each component **of the noise reduction system** to enable it to be easily located and identified, and a specification of the materials used;"

Paragraph 3.2.5., amend to read:

"3.2.5. Cross-sectional drawings indicating the dimensions of the exhaust **and intake** systems. A copy of these drawings shall be appended to the certificate referred to in Annex 1."

Paragraph 3.3., amend to read:

"3.3. At the request of the technical service responsible for conducting approval tests, the motor cycle manufacturer shall, in addition, submit a sample of the ~~exhaust or silencing~~ **and intake** systems."

Paragraph 3.5., amend to read:

"3.5. A test report...

- (a) Details of the test site (e.g. surface temperature, **residual voids content** or absorption coefficient, etc.), test site location, ~~site orientation~~ **and** weather conditions including wind speed **and direction**, air temperature, barometric pressure, humidity;
- (b) The type of measuring equipment ~~including the windscreen~~;
- (d) The identification of the ~~vehicle~~ **motorcycle**, its engine, its transmission system, including available transmission ratios, **tyre manufacturer and commercial description of the tyres (i.e. trade name, speed index, load index)**, size ~~and type of tyres~~, tyre pressure, type approval number of the tyres (if available) ~~or tyre manufacturer and commercial description of the tyres (i.e. trade name, speed index, load index)~~, rated maximum net power, test mass, power to mass ratio index, $a_{wot\ ref}$, a_{urban} , **motorcycle** length;

...

- (l) All valid A-weighted sound pressure level values measured for each test, listed according to the side of the ~~vehicle~~ **motor cycle** and the ~~direction of the vehicle movement on the test site~~; and

..."

Paragraph 4.1., amend to read:

- "4.1. The components of the ~~exhaust or silencing~~ **noise reduction** system shall bear at least the following identifications:"

Paragraph 4.1.1., amend to read:

- "4.1.1. The trade name or mark of the manufacturer ~~of the exhaust or silencing system and of its components~~;"

Paragraph 4.1.2., amend to read:

- "4.1.2. The trade (**commercial**) description given by the manufacturer;"

Paragraph 4.1.4., amend to read:

- "4.1.4. For all original ~~silencers~~, **components of the noise reduction system (intake and exhaust silencers, catalysts and air filter)**, the "E" mark followed by the identification of the country which granted the component type approval.³

Paragraph 4.1.6., renumber as paragraph 4.2. and amend to read:

- "**4.2.** Such markings shall be indelible, clearly legible and also visible, in the position at which it is to be fitted to the ~~vehicle~~ **motorcycle**."

Paragraph 4.1.5., renumber as paragraph 4.3. and amend to read:

- "**4.3.** Any packing of original ~~replacement exhaust or silencing systems~~ **noise reduction system (intake and exhaust silencers, catalysts and air filter)**, shall be marked legibly with the words "original part" and the make and type references integrated together with the "E" mark and also the reference of the country of origin."

Paragraph 6.2., amend to read:

- "6.2. Specifications regarding ~~sound levels~~ **noise emissions**"

Paragraph 6.2.1., amend to read:

- "6.2.1. The ~~sound~~ **noise** emissions ..."

Paragraph 6.2.2., amend to read:

- "6.2.2. **A-weighted sound level is used to estimate motor cycle noise emissions.**
The test results ..."

Paragraph 6.2.3., amend to read:

- "6.2.3. The test results ... and new ~~silencing~~ **noise reduction** systems) in **paragraph 6.2.4.** ~~Annex 6~~ to this Regulation for the category to which the motor cycle

³ The distinguish numbers of the Contracting Parties to the 1958 Agreement are reproduced in Annex 3 to Consolidated Resolution on the Construction of Vehicles (R.E.3), document ECE/TRANS/WP.29/78/Rev.2.

belongs. In any case, L_{wor} shall not exceed the limit value for L_{urban} by more than 5 dB."

Insert new paragraph 6.2.4., to read:

"6.2.4. Sound levels limits for motor cycles

<i>Category</i>	<i>Power-to-mass ratio index (PMR)</i>	<i>Limit value for L_{urban} in dB(A)</i>
First category	PMR \leq 25	73
Second category	25 < PMR \leq 50	74
Third category	PMR > 50	77^a

^a For motor cycles tested in second gear only in Annex 3, the limit value is increased by 1 dB(A) [until the date in paragraph 12.7. Data for affected vehicles shall be studied, and discussions shall be made in case of further extension.]"

Paragraph 6.3., amend to read:

"6.3. Additional ~~sound~~ **noise** emission provisions"

Paragraph 6.3.2., amend to read:

"6.3.2. The ~~vehicle~~ **motor cycle** type to be approved shall meet the requirements of ~~Annex 7~~ **Annex 6** to this Regulation. If the motor cycle has user selectable software programs or modes which affect the sound emission of the ~~vehicle~~ **motor cycle**, all these modes shall be in compliance with the requirements in ~~Annex 7~~ **Annex 6**. Testing shall be based on the worst case scenario."

Paragraph 6.3.3., amend to read:

"6.3.3. In the ... the manufacturer shall provide a statement in accordance with ~~Annex 8~~ **Annex 7** that the ~~vehicle~~ **motor cycle** type to be approved complies with the requirements of paragraphs 6.3.1. and 6.3.2. of this Regulation."

Paragraph 6.4., amend to read:

"6.4. Additional specifications regarding exhaust ~~or silencing~~ **and intake** systems filled with fibrous material"

Paragraph 6.4.1., amend to read:

"6.4.1. If the exhaust or ~~silencing~~ **intake** systems of the motor cycle contains fibrous materials the requirements of Annex 5 shall apply. ~~If the intake of the engine is fitted with an air filter and/or an intake noise absorber which is (are) necessary in order to ensure compliance with the permissible sound level, the filter and/or absorber shall be considered to be part of the silencing system, and the requirements of Annex 5 shall also apply to them.~~"

Paragraph 6.5., amend to read:

"6.5. Additional prescriptions related to tamperability and manually adjustable multi-mode ~~exhaust or silencing~~ **noise reduction** systems."

Paragraph 6.5.1., amend to read:

"6.5.1. All ~~exhaust or silencing~~ **noise reduction** systems"

Paragraph 6.5.2., amend to read:

"6.5.2. ~~Exhaust or silencing~~ **Noise reduction** systems with multiple, manually adjustable operating modes shall meet all requirements in all operating modes. The reported ~~noise sound~~ **noise sound** levels shall be those resulting from the mode with the highest ~~noise~~ levels.

Paragraph 7., amend to read:

"7. Modification and extension of the approval of the motor cycle type ~~or of the type of exhaust or silencing system(s)~~"

Paragraph 7.1., amend to read:

"7.1. Every modification of the motor cycle type or of the ~~exhaust or silencing~~ **noise reduction** system shall be notified to the type approval authority which approved the motor cycle type. The type approval authority may then either:"

Paragraph 8.2., amend to read:

"8.2. In order ... limits laid down in ~~Annex 6~~ **paragraph 6.2.4.** of this Regulation."

Paragraph 8.3., amend to read:

"8.3. For conformity ... according to ~~Annex 7~~ **Annex 6**, the measured sound levels shall not exceed by more than 1.0 dB(A) the limits given in paragraph 2.6 of ~~Annex 7~~ **Annex 6.**"

Annex 1

Paragraph 6.2.,

"6.2. Number of gears **and gear ratios:**"

Insert a new paragraph 6.3., to read:

"6.3.1. **Final drive ratio(s)**"

Paragraph 7.1., amend to read:

"7.1. Exhaust ~~silencer~~ **system**"

Insert a new item 7.1.1., to read:

"7.1.1. **Exhaust silencer(s)**"

Items 7.1.1. to 7.1.3. (former), renumber as 7.1.1.1. to 7.1.1.3 respectively.

Insert new items 7.1.2. to 7.1.2.3., to read:

"7.1.2. **Catalyst(s)**....."

7.1.2.1. **Manufacturer or authorized representative (if any):**

7.1.2.2. **Model:**

7.1.2.3. **Type:****in accordance with drawing No...**"

Item 7.2., amend to read:

"7.2. Intake ~~silencer~~ **system**"

Items 7.2.1. to 7.2.3., shall be deleted

Insert new items 7.2.1. to 7.2.2.3., to read:

"7.2.1. **Air filter**"

- 7.2.1.1. **Manufacturer or authorized representative (if any):**
 7.2.1.2. **Model:**
 7.2.1.3. **Type:**in accordance with drawing No...
 7.2.2. **Intake silencer(s)**.....
 7.2.2.1. **Manufacturer or authorized representative (if any):**
 7.2.2.2. **Model:** "
 7.2.2.3. **Type:**in accordance with drawing No...."

Items 8. to 15.1. (former), shall be deleted.

Insert new items 8. to 8.4., to read:

- "8. **Tyres**
 8.1 **Tyre manufacturer(s):**.....
 8.2. **Commercial description(s) of the type of tyre (by axle), (e.g. trade name, speed index, load index):**
 8.3. **Tyre size(s) (by axle):**.....
 8.4 **ECE type approval number(s) of tyre(s):**"

Insert new items 9. to 9.2., to read:

- "9. **Masses**
 9.1. **Maximum permissible gross mass...kg**
 9.2 **Power to mass ratio index (PMR):**"

Items 16. to 18. (former), renumber as items 10 to 12. respectively.

Insert a new item 12.1., to read:

- "12.1. **Sound pressure level $L_{wot(i)}$:**dB(A)"

Items 19. to 20. (former), shall be deleted.

Items 21. to 29. (former), renumber as items 13 to 20. respectively.

Annex 3

Paragraph 2.4.1., amend to read

- "2.4.1. ... If a vehicle has two or more exhaust outlets spaced ~~less~~ **not more** than 0.3 m ..."

Appendix 2, the figure, amend to read:

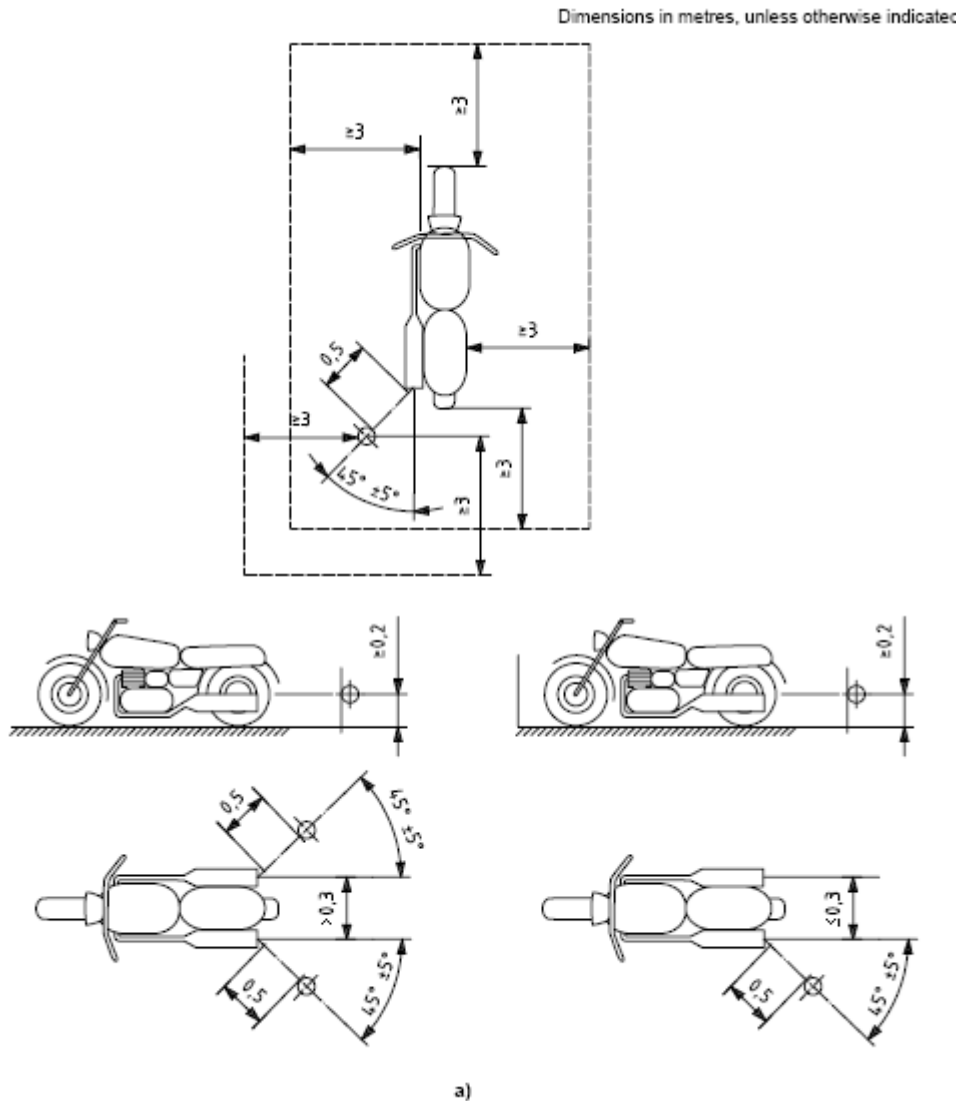

Annex 5

The title, amend to read:

"Exhaust or ~~silencing~~ intake systems containing fibrous material"

Paragraph 1., amend to read:

- "1. Fibrous absorbent material shall be asbestos-free and may be used in the construction of the exhaust or ~~silencing~~ intake systems only if suitable devices ensure that the fibrous material is kept in place for the whole time that the exhaust or ~~silencing~~ intake system is being used and the exhaust-~~or silencing~~ system meets the requirements of any one of paragraphs 1.1., 1.2. and 1.3., and the intake system meets the requirements of any one of paragraphs 1.1., 1.3.1., 1.3.3."

Annex 6, shall be deleted.

Annex 7 and 8, renumber as Annexes 6 and 7.

II. Justification

1. *Paragraph 1.:* L₃ category refers only to motor cycles.
2. *Paragraph 2.2.:* The Regulation refers to motor cycle as regards its noise emissions, therefore the exhaust system may not be specified here.
3. *Paragraph 2.2.3., 2.3., 2.3.1., 2.4., 2.5., 3.2.2., 3.2.3., 3.2.4.:* "Noise reduction system" is fuller and more correct term, as it includes intake and exhaust systems, as well as engine shields or capsules, etc. The terms "exhaust system" and silencing system bring mess in definitions.
4. *Paragraph 2.6. and below.:* Since the Regulation concerns only motor cycles, it is proposed to apply this term instead of "vehicle".
5. *Paragraph 3.1.:* The term "noise emissions" is more correct than the term "sound emissions", which does not reflect the negative characteristic of this phenomenon. Besides the term "noise emissions" is already in use in UN Regulation No. 51. The uniformity should be kept.
6. *Paragraph 3.2.5.:* Drawings of the intake system are also necessary.
7. *Paragraph 3.3.:* The intake system is also needed.
8. *Paragraph 3.5. (a), (b) and (l):* The superfluous data are removed (site orientation, windscreen, direction of movement). Such data do not bear any information about tests.
9. *Paragraph 3.5. (d).:* The rearrangement of listings is necessary to set these requirements in order.
10. *Paragraph 4.:* The more correct list of requirements on identification of system of noise reduction of a motor cycle is proposed. It includes the both intake system of and catalyts.
11. *Paragraph 6.2.:* In this context "noise emission" is more correct than "sound level".
12. *Paragraphs 6.2.1., 6.3., 6.3.2., 6.3.3.:* In this context "noise emission" is more correct than "sound emission".
13. *Paragraph 6.2.2.:* Since the test results are presented in dB (A), it is specified that the measurements are taken in dB (A).
14. *Paragraph 6.2.3.:* "Silencing systems" is substituted by "noise reduction systems", which seems more correct.
15. *Paragraph 6.2.4. and renumbering of Annexes.:* For the uniformity of drafting on the UN Regulations concerning vehicle noise and also because of the limiting values of a sound level is the basic criterion of the motor cycle noise emission, it is proposed to take the sound levels limits out of the Annex and put them in the main text of the Regulation. Therefore Annex 6 that recently contained those limits is proposed for deletion, Annexes 7 and 8 are renumbered to 6 and 7 respectively.
16. *Paragraphs 6.4. and 6.4.1.:* "Silencing systems" have been removed, "intake systems" have been added.
17. *Paragraph 6.4.1.:* The second sentence does not bear any information as it is already described above that the intake system is a part of the noise reduction system of a motorcycle.
18. *Paragraphs 6.5., 6.5.1., 6.5.2., 7.1.:* "Exhaust or silencing systems" is substituted by "noise reduction systems", which seems more correct.
19. *Paragraph 6.5.2.:* For the same reason "noise level" is substituted by "sound level".
20. *Paragraph 7.:* The exhaust system is deleted as communication on type approval relates to complete motor cycles.
21. *Paragraphs 8.2 and 8.3.:* The references are corrected as the Annex 6 is deleted and the paragraph 6.2.4 is added.

22. *Annex 1, paragraph 6.2.:* The gear ratios are considered as an important feature of a motorcycle type.
23. *Annex 1, paragraphs 7.1., 7.2.:* The information is extended to include features of important parts of a noise reduction system.
24. *Paragraphs 8. to 29.:* These paragraphs have been revised to set the information more properly and avoid duplication of data, which are available in the test report.
25. *Annex3, Appendix 2:* The mathematical sign " \geq " is related to a distance between silencers. Therefore it should be changed to " \leq ".
26. *Annex 5. Heading and paragraph 1.:* "Exhaust or silencing systems" is substituted by "exhaust or intake systems", which seems more correct.
27. *Annex 5, paragraph 1.:* The paragraphs, which are referred to for exhaust and intake systems have been separated, because heating of the fibrous material contained in the intake system to the temperature of 650 °C is senseless.
