



# Federal Register

---

**Monday,  
May 17, 2004**

---

**Part IV**

## **Department of Transportation**

---

**National Highway Traffic Safety  
Administration**

---

**49 CFR Parts 571 and 598  
Federal Motor Vehicle Safety Standards;  
Side Impact Protection; Side Impact  
Phase-In Reporting Requirements;  
Proposed Rule**

**DEPARTMENT OF TRANSPORTATION****National Highway Traffic Safety Administration****49 CFR Parts 571 and 598**

[Docket No. NHTSA-2004-17694]

RIN 2127-AJ10

**Federal Motor Vehicle Safety Standards; Side Impact Protection; Side Impact Phase-In Reporting Requirements**

**AGENCY:** National Highway Traffic Safety Administration (NHTSA), Department of Transportation.

**ACTION:** Notice of proposed rulemaking (NPRM).

**SUMMARY:** This NPRM would substantially upgrade the agency's side impact protection standard, especially by requiring protection in crashes with narrow objects and protection against head injuries in side impact crashes with both narrow objects and other vehicles.

First, it would upgrade the standard by requiring that all passenger vehicles with a gross vehicle weight rating of 4,536 kilograms (10,000 pounds) or less protect front seat occupants against head, thoracic, abdominal and pelvic injuries in a vehicle-to-pole test simulating a vehicle's crashing sideways into narrow fixed objects like telephone poles and trees. To meet the head injury criteria in the pole test, vehicle manufacturers would likely need to install dynamically deploying side head protection systems, such as head air bags or inflatable air curtains that drop down from the roof line above the door frame. Air curtains can reduce head injuries in side crashes of passenger vehicles with poles and trees as well as side impacts from vehicles with high front ends. They also can help reduce partial and full ejections through side windows. Compliance with the pole test would be determined in two test configurations, one using a new, second-generation test dummy representing mid-size adult males and the other using a new test dummy representing small adult females.

Second, this NPRM would upgrade the standard's existing vehicle-to-vehicle test that requires protection of front and rear seat occupants against thoracic and pelvic injuries in a test that uses a moving deformable barrier to simulate a moving vehicle's being struck in the side by another moving vehicle. This NPRM would upgrade that test by requiring protection against head injuries. It would replace the mid-size

male dummy currently used in that test with the new mid-size male dummy mentioned above and require compliance with the head, thoracic and pelvic injury criteria developed for the new dummy. It would also enhance protection for small adult occupants by adding the new small female test dummy mentioned above and requiring compliance with the injury criteria developed for that dummy. Thus, the number of test configurations would increase from one to two.

**DATES:** You should submit your comments early enough to ensure that Docket Management receives them not later than October 14, 2004.

**ADDRESSES:** You may submit comments (identified by the DOT DMS Docket Number) by any of the following methods:

- Web site: <http://dms.dot.gov>.

Follow the instructions for submitting comments on the DOT electronic docket site.

- Fax: 1-202-493-2251.

• Mail: Docket Management Facility; U.S. Department of Transportation, 400 Seventh Street, SW., Nassif Building, Room PL-401, Washington, DC 20590-001.

• Hand Delivery: Room PL-401 on the plaza level of the Nassif Building, 400 Seventh Street, SW., Washington, DC, between 9 a.m. and 5 p.m., Monday through Friday, except Federal holidays.

• Federal eRulemaking Portal: Go to <http://www.regulations.gov>. Follow the online instructions for submitting comments.

**Instructions:** All submissions must include the agency name and docket number or Regulatory Identification Number (RIN) for this rulemaking. For detailed instructions on submitting comments and additional information on the rulemaking process, see the Public Participation heading of the **SUPPLEMENTARY INFORMATION** section of this document. Note that all comments received will be posted without change to <http://dms.dot.gov>, including any personal information provided. Please see the Privacy Act discussion under the Public Participation heading.

**Docket:** For access to the docket to read background documents or comments received, go to <http://dms.dot.gov> at any time or to Room PL-401 on the plaza level of the Nassif Building, 400 Seventh Street, SW., Washington, DC, between 9 a.m. and 5 p.m., Monday through Friday, except Federal holidays.

**FOR FURTHER INFORMATION CONTACT:** For non-legal issues, you may call Dr. William Fan of the NHTSA Office of

Crashworthiness Standards, at 202-366-4922.

For legal issues, you may call Deirdre R. Fujita of the NHTSA Office of Chief Counsel, at 202-366-2992.

You may send mail to these officials at the National Highway Traffic Safety Administration, 400 Seventh St., SW., Washington, DC 20590.

**SUPPLEMENTARY INFORMATION:**

- I. Introduction
- II. Executive Summary
- III. Safety Problem
- IV. Regulatory, Research and Technological Developments—1990 to Present
  - a. 1990 Simulated Vehicle-to-Vehicle Test—Chest and Pelvic Injury Criteria
  - b. 1995 Establishment of Upper Interior Impact Protection Requirements
  - c. 1996 First Inflatable Side Impact Protection Systems
  - d. 1997 Report to Congress re Possibility of Harmonizing U.S. and European Vehicle-to-Vehicle Tests
  - e. 1997 Head Injury Protection Criteria and First Generation Side Impact Test Dummy Capable of Measuring Head Impact Forces
  - f. 1998 Pole Test To Evaluate Inflatable Side Impact Head Protection Systems
  - g. Grant of 1998 Petition To Upgrade Side Impact Protection Standard
  - h. 1997-1999 NHTSA Research re Vehicle-to-Vehicle Test Harmonization
  - i. 1999-2000 Report to Congress and Response to Petition re Vehicle-to-Vehicle Test Harmonization
  - j. 2000-2003 NHTSA Research re Side Impact Dummies, Injury Criteria, and Crash Tests
  - k. Current Status of Second and Next Generation Side Impact Dummies
  - l. Industry Efforts To Improve Compatibility in Vehicle-to-Vehicle Crashes
- V. Existing Standard
- VI. Proposed Vehicle-to-Pole Test Procedures, Dummies and Injury Criteria
  - a. Test Procedure
    1. Speed
    2. Angle of Impact
    3. Positioning the Seat and Impact Reference Line
  - b. Dummies and Injury Criteria
    1. 50th Percentile Male Dummy (ES-2re)
      - A. Background
      - B. Injury Criteria
      - C. Oblique Pole Tests With ES-2 and ES-2re
      - D. Comparing the ES-2re to the SID-H3
    2. 5th Percentile Female Dummy (SID-IIsFRG)
      - A. Background
      - B. Injury Criteria
      - C. Oblique Pole Tests With 5th Percentile Female Dummy
  - c. FMVSS No. 201 Pole Test Conditions
- VII. Proposed Improvements of Moving Deformable Barrier Test
  - a. Replacement of Existing 50th Percentile Male Dummy With ES-2re and Addition of Injury Criteria
  - b. Addition of 5th Percentile Female Dummy (SID-IIsFRG) and Injury Criteria
- VIII. Other Issues

- a. Struck Door Must Not Separate From Vehicle
- b. Rear Seat
- c. Interaction With Other Side Impact Programs
  - 1. Out-of-Position Criteria
  - 2. FMVSS No. 201 Pole Test
  - d. Harmonization
- IX. Estimated Benefits and Costs of Proposed Pole Test
- X. Proposed Leadtime and Phase-In
- XI. Rulemaking Analyses and Notices
- XII. Public Participation

## I. Introduction

This rulemaking is a first step toward achieving two goals: improving side impact protection and reducing the risk of ejection. Both goals have been highlighted in recent agency planning documents. On July 25, 2002, the agency published a notice requesting public comment on a comprehensive multi-year vehicle safety rulemaking and research plan (67 FR 48599; Docket No. NHTSA-2002-212391). Two months later, NHTSA Administrator Jeffrey W. Runge, M.D., formed Integrated Project Teams (IPTs) to conduct an in-depth review of four top priority safety areas. Among them are vehicle compatibility and rollover. Those two areas were selected because they represent the key safety issues presented by the changing composition of the passenger vehicle fleet. The sales and registrations of light trucks, buses and multipurpose passenger vehicles (LTVs) as a percentage of the light vehicle fleet have steadily increased since 1984. In fact, sales of LTVs reached 50 percent of all new light vehicles sold in 2001. The IPTs were chartered to develop comprehensive, science and evidence-based analyses to identify innovative solutions and recommend effective strategies.

Significant progress has been made in addressing these priorities. On June 18, 2003, NHTSA announced the availability of two reports, "Initiatives to Address Vehicle Compatibility,"<sup>1</sup> and "Initiatives to Address the Mitigation of Rollovers,"<sup>2</sup> based on the work of the vehicle compatibility and rollover IPTs (68 FR 36534). Initiatives to upgrade side impact protection and reduce ejection figure prominently in both reports. One month later, the agency announced the availability of its final priority plan, "NHTSA Vehicle Safety Rulemaking and Supporting Research: 2003-2006"<sup>3</sup> (68 FR 43972; July 18, 2003). The plan, which reflects the

results of a comprehensive examination of areas of possible improvements, "outlines the agency's vehicle safety rulemaking actions for the period 2003 to 2006 that offer the greatest potential for saving lives and preventing injury." Upgrading side impact protection is one of the most promising of those actions.

Today's proposal to upgrade the agency's side impact protection standard begins the implementation of the initiatives in the agency's report on improving crash compatibility between passenger cars and LTVs ("Initiatives to Address Vehicle Compatibility," supra.) This proposal would require vehicle manufacturers to assure side impact protection for a wider range of occupant sizes and over a broader range of seating positions. It would likely lead to the installation of new technologies, such as side curtain air bags and torso side air bags capable of improving head and thorax protection to occupants of vehicles that are laterally struck by a higher-riding LTV. (These different side air bag systems are described in a glossary set forth in Appendix A to this preamble.)

## II. Executive Summary

In 1990, the agency amended its side impact protection standard, Federal Motor Vehicle Safety Standard (FMVSS) No. 214, "Side Impact Protection," to include a dynamic test, the first anywhere in the world, that assesses occupant protection when a vehicle is struck in the side by another vehicle. A moving deformable barrier is crashed into the side of a vehicle in a manner that simulates a 90-degree side impact between two moving vehicles at an intersection. The standard addresses thoracic and pelvic injuries to struck-side occupants in those vehicle-to-vehicle crashes.

However, the standard does not address side crashes into fixed narrow objects, which account for approximately 20 percent of deaths and serious injuries that occur in side impacts. It also does not address head injuries, which account for 43 percent of the total deaths and serious injuries in the target population addressed by this NPRM. For smaller-statured occupants, head injury represents a higher proportion of the serious injuries than it does for larger occupants as a result of relatively more head contacts with the striking vehicle.<sup>4</sup>

The current state of knowledge and practicability of measures that could be

taken to improve side impact protection are considerably greater than they were just a decade ago. Extensive work by NHTSA, the industry, and others in the safety community have led to substantial progress in dummies, injury criteria and countermeasures. Inflatable side protection systems have become common in current production vehicles. They vary widely in designs, sizes, mounting locations and methods of inflation, and areas of coverage. For example, variations of side impact protection systems include door-mounted thorax bags, seat-mounted thorax bags, seat-mounted head/thorax bags, and head protection systems that deploy from the roof rails (e.g., inflatable tubes and curtains).

Based on this progress and the growing significance of vehicle compatibility issues, NHTSA is proposing to upgrade FMVSS No. 214 substantially by requiring all passenger vehicles with a gross vehicle weight rating (GVWR) of 4,536 kilograms (kg) or less (10,000 lb or less) to protect front seat occupants against head, thoracic and pelvic injuries in a vehicle-to-pole test simulating a vehicle's crashing sideways into narrow fixed objects like telephone poles and trees.<sup>5</sup> This would be the first time that head injury criteria would need to be met under the standard. The vehicle-to-pole test is similar to the one currently used optionally in FMVSS No. 201, except that NHTSA proposes to change the angle of impact from 90 to 75 degrees and increase the test speed from 29 to 32 kilometers per hour (km/h) (18 to 20 miles per hour (mph))<sup>6</sup>.

Vehicles would need to meet the injury criteria using new dummies representing mid-size males and small females. Crash data indicate that 35 percent of all serious and fatal injuries to near-side occupants in side impacts occurred to occupants 5 feet 4 inches (or 163 centimeters)(cm) or less, which are better represented by the small female dummy. Thus, the agency believes that use of both dummies, instead of just the

<sup>5</sup> The pole test would apply to the driver and front outboard passenger seats, and not to the rear seats. In contrast, the moving deformable barrier test applies to both the front and rear outboard seating positions on the side of the vehicle struck by the barrier.

In the pole and MDB tests, both sides of the vehicle are subject to testing by NHTSA. Manufacturers must certify that the vehicle complies with the standard when either side of the vehicle is tested by NHTSA. The standard does not require NHTSA to test both sides of the vehicle.

<sup>6</sup> While 20 mph converts to 32.2 km/h, we propose rounding 32.2 km/h to 32 km/h.

<sup>1</sup> <http://www-nrd.nhtsa.dot.gov/departments/nrd-11/aggressivity/IPTVehicleCompatibilityReport/>.

<sup>2</sup> <http://www-nrd.nhtsa.dot.gov/vrtc/ca/capubs/IPTRolloverMitigationReport/>.

<sup>3</sup> <http://www.nhtsa.dot.gov/cars/rules/rulings/PriorityPlan/FinalVeh/Index.html>.

<sup>4</sup> Samaha R. S., Elliott D. S., "NHTSA Side Impact Research: Motivation for Upgraded Test Procedures," 18th International Technical Conference on the Enhanced Safety Of Vehicles Conference (ESV), Paper No. 492, 2003.

mid-size male dummy, will better represent the at-risk population.<sup>7</sup>

For the mid-size or 50th percentile male, NHTSA proposes to adopt a modified version of the European side impact dummy, the ES-2 dummy, for use in the test, since the overall dummy is technically superior to the SID-H3 50th percentile male test dummy currently used in FMVSS No. 201 and to the SID 50th percentile male test dummy currently used in FMVSS No. 214. The modified ES-2 dummy (known as the ES-2re) is superior in that it has improved biofidelity and enhanced injury assessment capability compared to the other dummies. A predecessor dummy, known as EuroSID-1, is currently specified by European governments for use in perpendicular side impact testing and work has been undertaken to replace that dummy with the ES-2re. The non-governmental European New Car Assessment Program (EuroNCAP) on side impact has used the ES-2 dummy since February 2003 in perpendicular MDB side impact tests.

The small or 5th percentile female dummy has been used by Transport Canada in crash tests in the late 1990s and early 2000, and is used by the Insurance Institute for Highway Safety (IIHS), a nonprofit group funded by insurers, in IIHS's side impact consumer information program which ranks vehicles based on performance when impacted perpendicularly by a moving barrier at about 30 mph. The countermeasures that are installed to meet the proposed pole test would need to enable the vehicle to meet the requirements when tested with both dummies, which would ensure protection for shorter drivers who sit closer to the steering wheel than the mid-size occupant.

We anticipate that vehicle manufacturers will install dynamically deploying side air bags to meet the proposed vehicle-to-pole test. The agency estimates that the proposals in this NPRM would prevent 686 fatalities and 880 MAIS 3 to 5 injuries a year when fully implemented throughout the light vehicle fleet.<sup>8</sup> Those benefits are based on an assumption that manufacturers would use a 2-sensor (per vehicle) combination air bag system. (This system would be the least costly countermeasure that manufacturers

could use to achieve compliance. Manufacturers might also install side air curtains or other measures that not only reduce head injuries, but also can help reduce ejections through side windows.) The cost for the 2-sensor combination air bag system is estimated to be \$121 per vehicle. We are proposing to provide significant lead time to ensure that the regulatory burden is practicable and feasible.

In addition, this NPRM proposes to upgrade the moving deformable barrier test in several ways. It would enhance the MDB test's existing chest and pelvis protection requirements and require compliance with head injury criteria. It proposes replacing the current 50th percentile male dummy with the new one mentioned above and requiring compliance with the criteria developed for that new dummy. The proposal would also enhance protection for smaller adult occupants by adding the new 5th percentile female dummy mentioned above and require compliance with the injury criteria for that dummy.

Mindful of the magnitude of this rulemaking and the principles for regulatory decisionmaking set forth in Executive Order 12866, Regulatory Planning and Review, NHTSA examined the benefits and costs of a variety of potential proposals and, based on that analysis, took reasonable steps to limit the scope of this NPRM. First, because rear seat occupants make up a small percentage of the seriously injured occupants in side crashes, NHTSA has focused the proposal for the pole test on the front seat. (We note that some side air curtains cover both front and rear side window openings and thus would also afford some head protection to rear seat occupants in the absence of a test applying to the rear seat.)

Second, the agency is not proposing a limit on chest deflection in tests using the 5th percentile female dummy. The modified SID-II's dummy appears to require further refinement in measuring chest deflection for oblique loading conditions, such as those present in the oblique pole and MDB tests, and so the agency wishes to further analyze test data before proceeding with a proposal limiting the chest deflection of the dummy in the tests proposed today. However, the agency will continue to monitor the chest deflection performance of vehicles in tests using the modified SID-II's dummy.

Third, NHTSA is also not proposing changes to the standard's MDB at this time. Initiatives to improve vehicle compatibility between passenger cars and LTVs in side crashes are likely to change the characteristics of striking

vehicles in the future, as countermeasures are pursued to reduce the aggressivity of LTVs in side impacts. Once the likely future changes to the fleet have been identified, we can determine how the FMVSS No. 214 barrier should be modified to better represent future striking vehicles in side impacts. We also believe that the countermeasures resulting from today's proposed pole test would encompass and go beyond those that would be likely to be installed as a result of a higher/heavier barrier.

### III. Safety Problem

In the 2001 Fatality Analysis Reporting System (FARS), there were 9,088 side impact fatalities. For our target population, we excluded from these side impact fatalities those cases which included rollovers as first event (203), rear seat occupants (732), middle front seat or unknown seat occupants (327), far-side occupants (2,601), children under 12 in the front seat nearside (71), and delta-Vs not in our assumed effectiveness range of 19 to 40 km/h (12 to 25 mph) (2,084). We also made an adjustment based on the estimated benefits that would result from the FMVSS No. 201 upper interior requirements for the A-pillar, B-pillar, and roof side rail (160).<sup>9</sup> This left us with a target population of 2,910 fatalities and 7,248 non-fatal serious to critical AIS 3-5 injuries.

The 2,910 fatalities were divided into three groups for the analysis: (a) Vehicle to pole impacts (599); (b) vehicle to vehicle or other roadside objects impacts, which include partial ejections in these cases (1,715); and (c) complete occupant ejections in non-rollovers (636). In this target population, 40 percent of the total fatalities are caused by head/face injuries, 38 percent by chest injuries and 8 percent by abdominal injuries. In contrast, for the 7,248 non-fatal AIS 3-5 target population, chest injuries are the predominant maximum injury source accounting for 59 percent, head/face injuries account for 13 percent, and abdominal injuries account for 6 percent. Combining all serious to fatal injuries, chest injuries account for 53 percent, head/face injuries account for 20 percent, and abdominal injuries account for 7 percent.

In April 2001, NHTSA analyzed fatalities in the 1991, 1995, and 1999 FARS files using non-rollover, near-side impact data. The fatalities occurred in the first and second rows of seats in

<sup>7</sup> You may inspect the dummies by contacting our Vehicle Research and Test Center in East Liberty, OH.

<sup>8</sup> The AIS, or Abbreviated Injury Scale, is used to rank injuries by level of severity. An AIS 1 injury is a minor one, while an AIS 6 injury is one that is currently untreatable and fatal. The Maximum Abbreviated Injury Scale, or MAIS, is the maximum injury per occupant.

<sup>9</sup> NHTSA also adjusted the target population by assuming increased seat belt use based on 2003 use rates.

light vehicles in side impacts with various objects. The percentage of vehicle-to-rigid narrow object impacts has remained stable at approximately 21

percent of the total number of fatal side impact crashes. The percentage of collisions with LTVs has increased, while the percentage of collisions with

passenger cars has decreased over time. The results of the analysis are presented below:

TABLE 1.—OCCUPANT FATALITY DISTRIBUTION  
[Non-rollover near-side impacts]

	Collisions with passenger cars (percent)	Collisions with LTVs (percent)	Collisions with rigid narrow objects (percent)	Collisions with other vehicles/objects (percent)
FARS 1991 MY 1987 and Later Light Vehicles .....	28.9	26.3	20.1	24.8
FARS 1995 MY 1991 and Later Light Vehicles .....	24.7	31.8	21.2	21.9
FARS 1999 MY 1995 and Later Light Vehicles .....	20.5	35.5	21.1	22.9

#### IV. Regulatory, Research and Technological Developments—1990 to Present

##### a. 1990 Simulated Vehicle-to-Vehicle Test—Chest and Pelvic Injury Criteria

FMVSS No. 214 was amended in 1990 to include dynamic requirements to improve the crashworthiness of vehicles in vehicle-to-vehicle side impact collisions (55 FR 45722; October 30, 1990). The amendments added a dynamic side impact test regulating the level of crash forces that can be experienced by an occupant when seated in a vehicle struck in a side impact. The dynamic requirements focused on thoracic protection because contact between the thorax and the side interior had been a primary source of serious injuries and fatalities and because further work was needed on head protection countermeasures, head injury criterion and test dummies capable of measuring the potential for head injuries in a side impact crash. The requirements were phased-in for passenger cars, beginning in 1993. They were extended in 1995 (60 FR 38749; July 28, 1995) to LTVs with a GVWR of 2,722 kilograms (6,000 lb) or less manufactured on or after September 1, 1998.

##### b. 1995 Upper Interior Impact Protection Requirements

In 1995, NHTSA issued a final rule amending FMVSS No. 201, "Occupant protection in interior impact," to require passenger cars, and trucks, buses and multipurpose passenger vehicles with a gross vehicle weight rating of 4,536 kg (10,000 lb) or less, to provide protection when an occupant's head strikes certain upper interior components, including pillars, side rails, headers, and the roof, during a crash. The amendments added procedures and performance requirements for a new in-vehicle test, which were phased in beginning in model year 1999.

##### c. 1996 First Inflatable Side Impact Protection Systems

Side impact air bags (SIABs) were first installed in Mercedes E-class cars and all Volvo passenger cars in model year (MY) 1996. In MY 1997, BMW, VW/Audi, Cadillac, Nissan, and Toyota chose to install SIABs in certain production car models. Since then, SIABs have become more commonly available in the nation's passenger vehicles.<sup>10</sup>

In 1996, NHTSA published an advance notice of proposed rulemaking (ANPRM) to obtain information in evaluating dynamic head protection systems, such as ways of testing these systems to assure that they yield sufficient safety benefits to justify amending the new requirements of FMVSS No. 201 to permit their installation. (61 FR 9136; March 7, 1996.)

##### d. 1997 Report to Congress re Possibility of Harmonizing U.S. and European Vehicle-to-Vehicle Tests

On September 16, 1996, in Congressional Conference Report 104-785 for the Department of Transportation and Related Agencies' Appropriations Act for fiscal year 1997, the conferees directed NHTSA to study the differences between the U.S. and then-proposed European side impact regulations and to develop a plan for achieving harmonization of these regulations. In response to that directive, NHTSA submitted a side impact harmonization plan to Congress in April 1997 ("Report to Congress NHTSA Plan for Achieving Harmonization of the U.S. and European Side Impact Standards," April 1997, see docket NHTSA 1998-3935-1 of the

<sup>10</sup>In 1996, under 2% of the passenger cars sold in the U.S. had chest side air bags installed as compared to around 38% in 2002. Also, in 1998, only 0.04% of passenger cars sold in the U.S. had head side air bag systems as compared to 22% in 2002.

Department's Docket Management System). NHTSA said that it would determine the potential for international harmonization by:

1. Analyzing past research and performing new tests to determine the relative safety benefits offered by each regulation.

2. Coordinating with industry and other interested groups to establish consensus on the activities, eliminate duplication of work, and reduce cost.

3. Determining if functional equivalence exists or can be established between the two requirements.

4. Coordinating with the European Union (EU) to assess harmonization options and approaches.

With respect to the third step, we described how we would follow our functional equivalence process in determining whether FMVSS No. 214 and the modified European regulation are functionally equivalent (49 CFR part 553, Appendix B). This process is used to determine whether the vehicles or equipment manufactured under a foreign standard produce more or at least as many safety benefits as those produced by the vehicles or equipment manufactured under a similar U.S. standard.

##### e. 1997 Head Injury Protection Criteria and First Generation Side Impact Test Dummy Capable of Measuring Head Impact Forces

The Head Injury Criterion (HIC) for lateral impacts was developed in 1997, when the agency published an NPRM proposing to add an optional vehicle-to-pole side impact test to FMVSS No. 201. 62 FR 45202; August 26, 1997. An anthropomorphic test dummy that was capable of measuring crash forces to the head in a side impact was also developed in 1997. The SID-H3 dummy, specified in 49 CFR part 572, subpart M, is a SID dummy with a Hybrid III head/neck system. The Hybrid III head is instrumented with a tri-axial accelerometer package,

positioned to measure the acceleration of the center of gravity. This permits the measurement of HIC. The SID-H3 dummy is currently used in the FMVSS No. 201 optional vehicle-to-pole test (see below) and in NHTSA's New Car Assessment Program (NCAP) for side impact testing.

*f. 1998 Pole Test To Evaluate Inflatable Side Impact Head Protection Systems*

On August 4, 1998, NHTSA published a final rule amending the upper interior impact requirements of FMVSS No. 201, to permit, but not require, the installation of dynamically deploying upper interior head protection systems that were then being developed by some vehicle manufacturers to provide added head protection in lateral crashes (63 FR 41451). Compliance with the original upper interior impact requirements is tested at specified points called "target points." Since compliance is often not practicable at target points located near the places where these dynamic systems are stored before they are deployed, vehicles equipped with the dynamic systems are allowed to meet alternative requirements at those points. These vehicles are also required to meet new requirements to ensure that these dynamic systems enhance safety. That final rule added procedures and performance requirements for testing the deployment of these systems and their protective capability through a combination of in-vehicle tests and a full-scale vehicle-to-pole crash test. In the crash test, the vehicle is propelled at a speed between 24 km/h (15 mph) and 29 km/h (18 mph) into a rigid pole at an angle of 90 degrees. (This NPRM refers to this FMVSS No. 201 pole test as the "29 km/h (18 mph)" pole test.) The pole is aimed at the head of a SID-H3 dummy seated in the front outboard seating position. The pole test injury criterion is HIC of 1000. (63 FR 41451; August 4, 1998.)

*g. Grant of 1998 Petition To Upgrade Side Impact Protection Standard*

In July 1998, Advocates for Highway and Auto Safety (Advocates) submitted a petition for rulemaking requesting NHTSA to upgrade FMVSS No. 214 in several ways. First, Advocates contended that the injury criteria are not stringent enough, arguing that neither the occupants of passenger cars nor small LTVs are being provided adequate protection when their vehicles are struck by higher, heavier, and more aggressive LTVs. Second, they believed the MDB is not high/heavy enough because the barrier weight/height were originally designed to represent a vehicle fleet that was projected to be

lighter and smaller than the current fleet. They stated that since 1988, the passenger car fleet has not changed significantly while the LTV fleet has grown in average weight and number. Third, they thought that EuroSID-1 has advantages to SID because of additional measurement capability. They recommended the following: Amending FMVSS No. 214 to a higher safety performance level such that superior side impact air bags would be developed and installed in vehicles as standard equipment; replace the quasi-static door crush test with a side-to-pole impact test like that used under the recent FMVSS No. 201 upgrade; lastly, replace SID with EuroSID-1. The agency granted the petition because it believed that the side impact research activities it had planned would fully address the issues raised by the petition.

*h. 1997-1999 NHTSA Research re Vehicle-to-Vehicle Test Harmonization*

As a first step in assessing the functional equivalence of the U.S. and European side impact regulations, we tested vehicles that were certified to FMVSS No. 214 using the procedures and criteria of EU 96/27/EC (as modified, with a test dummy placed in the rear outboard seating position in addition to the front outboard position). The vehicles provided a range of marginal to good performers in FMVSS No. 214 tests and represented a wide range of manufacturers. The results indicated the ranking of the vehicles, according to compliance margin, when tested under EU 96/27/EC was not the same as when they were tested under FMVSS No. 214.

Additionally, a measurement anomaly in the European test dummy (EuroSID-1) related to the rib displacement was present in most, if not all, tests. This anomaly, along with the limited amount of comparative test data, did not allow a positive determination of functional equivalence of the two side impact regulations.

*i. 1999-2000 Report to Congress and Response to Petition re Vehicle-to-Vehicle Test Harmonization*

Based on our testing of eight vehicles that were certified to FMVSS No. 214 using the procedures and criteria of EU 96/27/EC, we informed Congress that we could not conclude from this set of testing whether vehicles designed to meet FMVSS No. 214 would meet the EU regulation. The agency also determined that the lighter and less stiff EU MDB was less representative of the current and future U.S. fleet than the current FMVSS No. 214 MBD, and that side impact countermeasures that would

be based on the EU test might therefore not lead to enhanced real world safety. (See NHTSA's report to Congress on the agency's progress in assessing the functional equivalence of the two regulations: "Status of NHTSA Plan for Side Impact Regulation Harmonization and Upgrade, Report to Congress, March 1999," Docket NHTSA-98-3935-10.)

Also based on that testing, we denied most aspects of a 1997 petition for rulemaking from the Association of International Automobile Manufacturers (AIAM), the Insurance Institute for Highway Safety, and the American Automobile Manufacturers Association. These petitioners asked us first to determine that the dynamic side impact provisions of a European regulation (consisting of performance requirements, crash test barrier, test barrier face, and test procedures) are at least "functionally equivalent" to those in FMVSS No. 214. (65 FR 33508; May 24, 2000.) Based on the assumption that that determination would be made, the petitioners then asked that we add the dynamic provisions of the European regulation to FMVSS No. 214 as a compliance alternative in the short run. Based on their belief that the European dynamic provisions are superior to those in FMVSS No. 214 in some respects, they also wanted us to replace the current dynamic provisions of FMVSS No. 214 with those of the European regulation (slightly modified) in the long run. In addition to our inability to determine that the European standard was at least functionally equivalent to FMVSS No. 214, we noted that the European barrier was less representative than the FMVSS No. 214 barrier of the side impact crash environment in this country.

However, we granted the portion of the petition requesting that we open a rulemaking proceeding to consider replacing the 50th percentile male side impact test dummy (SID) currently specified in FMVSS No. 214 with an improved version of the dummy (EuroSID-1) specified in the European regulation. We said that if the mechanical anomalies with EuroSID-1 could be solved, the greater measurement capabilities of the dummy would make its adoption attractive as a way of upgrading FMVSS No. 214. Thus, we said that our first steps would be to work with the Europeans to fix the dummy's mechanical problems. Once that is accomplished, we would consider issuing a proposal to replace SID with the improved side impact dummy. We noted that adopting a more advanced test dummy means that we would also be considering the appropriate injury criteria to adopt with

the dummy into our side impact protection standard. We said that if we eventually proposed to replace SID with an improved EuroSID-1, we might propose adopting the injury criteria now in EU 96/27/EC as well.

*j. 2000–2003 NHTSA Research re Side Impact Dummies, Injury Criteria, and Crash Tests*

In the 1999 Report to Congress, we outlined our side impact research plan for both harmonization and upgrade of FMVSS No. 214. Among other matters, the agency planned to improve the EuroSID-1 dummy to a new version, Eurosid-2 (ES-2), pursue incorporating a pole test using the ES-2 or SID-H3 dummy currently used in FMVSS No. 201's optional pole test, and study the benefits and costs of side air bags and the possible risks to out-of-position occupants. *Id.*, Appendix A.

NHTSA conducted or participated in extensive research following the research plan. We analyzed 1990–2001 crash data to determine characteristics of the occupants injured in near-side side impacts and how they were being injured, and to better understand the crash environment of vehicle-to-vehicle and narrow object side crashes, and found that head injuries and injuries to small statured occupants should be addressed. We fixed back-plate grabbing problems with the ES-2 dummy,<sup>11</sup> evaluated a 5th percentile female side impact dummy (SID-IIIs, see later section) and made determinations as to the dummies' suitability for crash testing. Injury criteria for occupant head, chest, abdomen and pelvis were also developed and/or evaluated. We conducted out-of-position testing of side air bags to assess risks of the SIABs to children. The agency also closely monitored the Insurance Institute for Highway Safety's (IIHS's) progress on developing that organization's side impact moving barrier consumer information test program, and assessed the degree to which our and IIHS's programs can best complement each other.

The results of these undertakings led us to decide to concentrate our efforts on improving head protection in side impacts by way of incorporating a pole test into FMVSS No. 214, with new test dummies capable of measuring head impact forces. An oblique (75 degree), 32 km/h (20 mph) crash test was developed. Full-scale oblique pole tests were conducted with the ES-2, SID-H3

and SID-IIIs dummies, with injury assessment references values developed for the injury mechanisms measured by the dummies. "NHTSA Side Impact Research: Motivation For Upgraded Test Procedures," Samaha, *et al.* (2003).

Full-scale side impact tests using a moving barrier were also conducted. These research projects were publicly presented in various forums, such as in a July 2002 NHTSA Research and Development Public Meeting<sup>12</sup> and in meetings of the International Harmonized Research Agenda (IHRA) Side Impact Working Group, and others.

*k. Current Status of Second and Next Generation Side Impact Dummies*

Today, there are new side impact dummies capable of measuring HIC in addition to the SID-H3 50th percentile male dummy. The ES-2 50th percentile male dummy has a well-developed biofidelic head with injury measurement capabilities. (The ES-2 has been modified with regard to rib extensions to address structural deficiencies identified by NHTSA in injury measurement of the chest in the dummy. The modified dummy, hereinafter referred to as "ES-2re," is described in detail later in this preamble.) There also is a test dummy representing a 5th percentile female, the SID-IIIs, that is capable of measuring forces to the head, neck, shoulder, thorax, abdomen and pelvis body regions. In addition, a next-generation 50th percentile male side impact dummy, known as WorldSID, is under development by industry representatives from the U.S., Europe and Japan and the European and Japanese governments (see Docket No. 2000–17252). This future dummy is intended to better predict a wider range of injury potential in side impact testing than current dummies. However, the dummy is not yet available.

*l. Industry Efforts To Improve Compatibility in Vehicle-to-Vehicle Crashes*

In response to the NHTSA Administrator's call for action to reduce the problem of vehicle incompatibility, some vehicle manufacturers have agreed to introduce changes to their LTVs to improve their compatibility in crashes with passenger cars. The Alliance of Automobile Manufacturers and IIHS announced a new voluntary industry commitment on December 4, 2003, to enhance occupant protection in front-to-

side and front-to-front crashes.<sup>13</sup> The industry initiative consists of improvements and research made in several phases focusing on changes to improve the geometric mismatch between the frontal structures of LTVs and passenger cars, and on accelerating the installation of side impact air bags.

Under Phase 1 of the initiative concerning front-to-side crashes, manufacturers<sup>14</sup> have agreed that, not later than September 1, 2007, at least 50 percent of each manufacturer's new passenger car and light truck (GVWR up to 8,500 lb) production intended for sale in the U.S. will be designed in accordance with either of the following head protection alternatives: (a) HIC<sub>36</sub> performance of 1000 or less for a SID-H3 crash dummy in the driver's seating position in an FMVSS No. 201 pole impact test, or (b) HIC<sub>15</sub> performance of 779 or less (with no direct head contact with the barrier) for a SID-IIIs crash dummy in the driver's seating position in the IIHS MDB side impact crash test.

In Phase 2, not later than September 1, 2009, 100 percent of each manufacturer's new passenger car and light truck (GVWR up to 8,500 lb) production will be designed in accordance with the IIHS MDB recommended practice of HIC<sub>15</sub> performance of 779 or less for a SID-IIIs crash dummy in the driver's seating position.<sup>15</sup>

The agency welcomes these efforts. They are important and necessary first steps to reduce the problems associated with vehicle incompatibility. Voluntary efforts to equip vehicles with these new designs and life-saving devices will begin saving increased numbers of lives sooner than through the traditional regulatory approach and will reduce the cost of complying with government regulations.

The oblique pole test proposed by this NPRM would be phased-in over three years beginning approximately four years from the publication date of a final rule. This leadtime is proposed to give adequate time for manufacturers to plan

<sup>13</sup> See Docket NHTSA-2003-14623.

<sup>14</sup> BMW Group, DaimlerChrysler Corporation, Ford Motor Company, General Motors, Honda, Hyundai, Isuzu, Kia, Mazda, Mitsubishi, Nissan, Subaru, Suzuki, Toyota and Volkswagen.

<sup>15</sup> Phase 3 consists of research using the IIHS barrier to assess the benefits of adding performance criteria for other body regions, specifically, the thoracic and abdominal regions. In addition, the research will also assess the potential benefits of performance criteria for a rear-seat test dummy and a 50th percentile male dummy (WorldSID). In Phase 4, the manufacturers and IIHS will investigate the opportunities to enhance structural interaction between vehicles in front-to-side crashes. The work will include an assessment of the IIHS side impact barrier with regard to the front-to-front compatibility performance criteria.

<sup>11</sup> NHTSA and the research arm of the EU (the European Enhanced Vehicle Safety Committee) recognized the potential for harmonizing on the use of a side impact test dummy and focused efforts on the evolution of the Eurosid into the ES-2re.

<sup>12</sup> "Side Impact Upgrade Research Update," <http://www-nrd.nhtsa.dot.gov/departments/nrd-01/Presentations/0702NRDmtg.html>.

for and design to specifications enabling their vehicles to meet an oblique test. Yet, if manufacturers began installing side impact air bags voluntarily on a widespread basis by 2007 with full implementation by 2009, we could see the fleet change years before implementation of the final rule. Many hundreds of lives could be saved in the near term.

The near term voluntary installation of side impact air bags would be a significant improvement to side crash protection. In the long term, installation of side air bag systems meeting our oblique pole test would take this improvement even further. The enhanced side impact air bags envisioned by this NPRM would save even more lives—hundreds more each year—than those saved by present technologies. Together, the industry's near term voluntary initiatives and the agency's long term regulatory solutions would address the side impact safety problem in a comprehensive and complementary way.

#### V. Existing Standard

FMVSS No. 214 specifies two types of performance requirements intended to protect the thoracic and pelvic regions of an occupant: "quasi-static" requirements and "dynamic" requirements. They apply to passenger cars and to multipurpose passenger vehicles, trucks, and buses with a GVWR of 4,536 kg (10,000 lb) or less and 6,000 lb or less, respectively.

The quasi-static requirements limit the extent to which the side door structure of a vehicle is pushed into the passenger compartment during a side impact. The standard requires each side door to resist crush forces that are applied by a piston pressing a 300 mm (12 inch) steel cylinder against the door's outer surface in a laboratory test. Since the requirement became effective in 1973, vehicle manufacturers have generally chosen to meet the requirement by reinforcing the side doors with metal beams.

The dynamic side impact test currently regulates the level of crash forces that can be experienced by an occupant's chest and pelvis when seated in a vehicle struck in a side impact. The dynamic requirements focus on thoracic pelvic protection because contact between the thorax and the side interior has been the primary source of serious injuries and fatalities.

The dynamic side impact test simulates a 90-degree intersection impact of a striking vehicle traveling 48 km/h (30 mph) into a target (*i.e.*, test vehicle traveling 24 km/h (15 mph)). This is achieved by running a moving

deformable barrier (MDB), which has all wheels rotated 27 degrees (crab angle) from the longitudinal axis, into the side of a stationary (test) vehicle at a 90-degree contact angle with a 54 km/h (33.5 mph) closing speed. At the initial contact, the longitudinal axes of the MDB and the test vehicle are perpendicular to each other. Two side impact dummies (SIDs) are used in the target vehicle. They are positioned on the struck side of the vehicle, one in the front seat with the other directly behind in the rear seat.

The MDB, which simulates the striking (*i.e.*, bullet) vehicle, has a mass of 1,361 kilograms (kg) (3,000 lb). The weight of the MDB and the geometry and material properties of the MDB's aluminum honeycomb contact face were derived from an adjustment of the average properties of the vehicle fleet (passenger cars and LTVs) in existence at the time of the development of the dynamic side impact regulation.

The test procedures focus on the dummy's chest and pelvis acceleration responses, which have been correlated with crash and test data regarding the conditions that produce serious occupant injuries. The instrumented dummies must not exhibit chest accelerations and pelvic accelerations above specified thresholds in order to pass the test. The maximum rib and spine accelerations measured on the chest are averaged into a single metric called the Thoracic Trauma Index (TTI(d)), which has an 85g limit for 4-door vehicles and a 90g limit for 2-door vehicles. The pelvic acceleration has a 130g limit.<sup>16</sup>

#### VI. Proposed Vehicle-to-Pole Test Procedures, Dummies and Injury Criteria

This NPRM proposes subjecting all vehicles<sup>17</sup> with a GVWR of 4,536 kg

<sup>16</sup> At this time, the agency is conducting an evaluation of FMVSS No. 214 to determine the effectiveness of side padding in reducing injury risks in side impacts. The first part of the evaluation, focusing on older model year vehicles, was completed in 1999 (DOT HS 809 004, NHTSA Technical Report, October 1999). The principal finding of this Phase-1 evaluation was a statistically significant association of TTI(d) with side impact fatality risks in model year (MY) 1981–1993 passenger cars. The observed relationship was stronger in 2-door cars than in 4-door cars.

<sup>17</sup> We propose excluding certain vehicles from the pole test: motor homes, tow trucks, dump trucks, ambulances and other emergency rescue/medical vehicles (including vehicles with fire-fighting equipment), vehicles equipped with wheelchair lifts, vehicles with raised or altered roof designs (see definitions in FMVSS No. 216, "Roof crush resistance"), and vehicles which have no doors, or exclusively have doors that are designed to be easily attached or removed so that the vehicle can be operated without doors. Many vehicles within these categories tend to have unusual side

(10,000 lb) or less to a dynamic vehicle-to-pole test that is similar to the one used to test some vehicles under FMVSS No. 201, except that we are proposing to change the angle of impact from 90 to 75 degrees (which would result in bags having to cover a larger area of the window exposed to occupant contact), and the test speed from 29 to 32 km/h (from 18 to 20 mph) (which would increase the severity of the test).<sup>18</sup> The purpose of requiring vehicles to satisfy this test is to ensure protection for occupants in a wider range of real world impacts than would be the case if we used the FMVSS No. 201 pole test.

A test dummy capable of measuring head injury potential would be used to represent a 50th percentile male. NHTSA proposes to adopt the ES–2re dummy for use in the pole test and in the barrier test, since, as discussed in a later section, we have tentatively determined that the dummy is technically superior to the SID–H3 test dummy used in FMVSS No. 201 and to the SID used in FMVSS No. 214. Alternatively, we request comments on using the SID–H3 dummy, since it can measure the risk of head injury. In addition, the NPRM proposes to use the modified SID–IIs dummy representing a 5th percentile female in both the pole and MDB tests. These dummies together better represent the at-risk population than those in the current standard.

#### a. Test Procedure

The agency is proposing to adopt a vehicle-to-pole test similar to that specified in FMVSS No. 201, with modifications relating to the angle and speed at which the test vehicle is propelled into the pole and to the test dummies used in the test and the positioning of those dummies. Based on the agency's experience in the FMVSS No. 201 compliance test program and in research done in support of today's NPRM, NHTSA tentatively concludes that the vehicle-to-pole test proposed today would better address the harm

structures that are not suitable for pole testing or have features, such as a lowered floor or raised roof, which could pose practicability problems in meeting the test. Comments are requested as to whether these vehicles should be excluded from only the HIC requirement or from both head and thoracic protection in the pole test. Comments are also requested on the need to exclude other types of vehicles from the pole test, such as convertibles that lack a roof structure enabling the installation of an air curtain. Suggestions that NHTSA exclude certain vehicle types should include information supporting the exclusion and a discussion of the extent of the exclusion (*e.g.*, from only the limit on HIC and not the limits on the other injury criteria of this proposal).

<sup>18</sup> The lateral component of the velocity would increase only 1.3 mph and not 2 mph.



caused by narrow object impacts in the real world, and lead manufacturers to equip their vehicles with upper interior, dynamically deploying head protection systems.<sup>19</sup>

The pole would have the same specifications as the pole used in the vehicle-to-pole test specified in FMVSS No. 201. It would be a vertical metal structure beginning not more than 102 mm (4 inches) above the lowest point of the tires on the striking side of the test vehicle when the vehicle is loaded as specified in the standard and extending above the highest point of the roof of the test vehicle. The pole would be 254 mm (10 inches)  $\pm$ 6 mm in diameter and set off from any mounting surface such as a barrier or other structure, so that a test vehicle would not contact such a mount or support at any time within 100 milliseconds of initiation of vehicle-to-pole impact.

As we noted in the rulemaking adding the vehicle-to-pole test to FMVSS No. 201 (63 FR 41451, 41457; August 4, 1998), the 254 mm (10 inch) pole diameter differs from the pole diameter specified by ISO in its final recommendation. ISO specifies a pole diameter of 350 mm (14 inches). The diameter of the rigid pole specified in FMVSS No. 201 was set at 254 mm in 1998 based on data from the Federal Highway Administration (FHWA) that the pole diameter at the window sill level for most poles involved in single vehicle side crashes was approximately 254 mm (10 inches). FHWA has informed NHTSA that there are 80 million timber utility poles in the roadside environment and that the most common size pole would have a diameter of 254 mm (10 inches) at the mid-height of passenger car doors. (See July 11, 2003 memorandum, a copy of which is in the docket.) Therefore, the 254 mm (10 inch) diameter rigid pole is representative of poles struck in side crashes in the U.S.

In a vehicle-to-pole test, the center line of the rigid pole is aligned with an impact reference line drawn on the struck side of the vehicle. In the procedures for the proposed oblique pole test, the impact reference line is in a vertical plane that passes through the center of gravity (CG) of the dummy's head in a direction that is 75 degrees from the vehicle's longitudinal center line. When conducting a test with the

50th percentile male dummy, the dummy and the vehicle seat would be positioned as in FMVSS No. 214 (mid-track fore-and-aft). When conducting a test with the 5th percentile female dummy, the vehicle seat would be positioned full-forward. In today's proposed pole test, the initial pole-to-vehicle contact must occur within an area bounded by two vertical planes located 38 mm (1.5 inches) forward and aft of the impact reference line.<sup>20</sup>

The agency's tests conducted in support of this NPRM demonstrate the repeatability of the proposed oblique pole test. NHTSA conducted three repeatability tests using the 1999 Nissan Maxima. The test results show that the location of first contact between the pole and vehicle exterior were in the range of 2 mm (0.08 in) and 15 mm (0.59 in) rearward of the impact reference line. In all three tests, the head of the ES-2 dummy contacted the pole. Later, NHTSA conducted two additional oblique pole tests using 1999 Volvo S-80 cars. Test results show that the contact lines were 5 mm (0.2 in) and 32 mm (1.26 in) rearward of the impact reference line. One test was conducted with a SID-H3 dummy and another with an ES-2 dummy. (While the head of both dummies contacted the pole, the SID-H3 head rotated off the air curtain directly into the pole, resulting in a very high HIC score.) In conclusion, in all five tests, the contact lines were within

<sup>20</sup> This NPRM proposes to refine how the vehicle test attitude is determined. Currently, the vehicle attitude is defined by measurements made from the ground (a level surface) to a reference point placed on the vehicle body above each of the wheels. These measurements are made with the vehicle in the "as delivered," "fully loaded," and "pre test (or as -tested)" conditions. This NPRM proposes that the method used to determine the test attitude be revised to align with that used in S13.3 of FMVSS No. 208. In that provision (specifying test procedures for a sled test), a test attitude is determined based on door-sill angle measurements to control the vehicle's pitch attitude. This NPRM also proposes to define the vehicle's roll attitude by a left to right angle measured along a fixed reference point at the front and rear of the vehicle at the vehicle longitudinal center plane. We have placed in the docket for comment a document setting forth the test procedures the agency is developing for the test.

NHTSA is proposing these changes because we believe that measuring the angles more directly, better facilitates and more accurately determines the vehicle attitudes than by use of the method in current S6.2 of FMVSS No. 214 (specifying test procedures for the MDB test). NHTSA also proposes to use the new method to define the vehicle test attitude for the MDB test. In the MDB test, the dummy and vehicle instrumentation, high-speed cameras, associated brackets and instrumentation umbilical lines that are added to the vehicle make it difficult sometimes to achieve the corridor between the as delivered and fully loaded attitudes, particularly at the right front position of the vehicle. (The agency also requests comments on keeping the present method used to determine vehicle test attitude, but adding a  $\pm$  10 mm tolerance.)

the 38 mm (1.5 inch) tolerance limit specified in the FMVSS No. 201 procedure and in this proposal, and the dummy's head contacted the pole directly in tests without an inflatable head protection system (HPS) or indirectly (including head rotating into the pole) in tests with an HPS.

The aforementioned tests were conducted with the vehicle seat positioned as specified in FMVSS No. 201.<sup>21</sup> Two oblique pole tests with the seat positioned mid-track, as specified in FMVSS No. 214, were completed with each of the 1999 Volvo S-80 and 2000 Saab vehicles. The impact lines for the four tests were all less than 19 mm (0.75 inches), well within the tolerance of 38 mm (1.5 inches) of the impact reference line.

#### 1. Speed

The proposed test speed is 32 km/h (20 mph). Crashes with delta-V 32 km/h (20 mph) or higher result in approximately half of the seriously injured occupants in narrow object near-side crashes. The derivation of the median delta-V (32 km/h or 20 mph) was based on all belted occupants with serious injuries in 1990-2001 NASS near-side crashes with narrow objects regardless of impact angles. Based on the lateral delta-V, a test speed of 29 km/h (18 mph) for the 90-degree pole test would be slightly over 30 km/h (19 mph) in a 75-degree pole test. Based on these data, NHTSA tentatively concludes that a 32 km/h (20 mph) test would be more appropriate than a 29 km/h (18 mph) test speed, because it better corresponds to the speed of real world crashes that result in serious injury.

Comments are requested on the alternative of a 29 km/h (18 mph) test speed. The 29 km/h (18 mph) test speed is used in the perpendicular pole test of FMVSS No. 201.

#### 2. Angle of Impact

This NPRM proposes that the angle at which a vehicle is propelled into the rigid pole would be 75-degrees rather than the 90-degree angle used in FMVSS No. 201. (This test using the 75-degree impact angle is sometimes referred to in

<sup>21</sup> Under the FMVSS No. 201 seating procedure, the dummy's head is positioned such that the point at the intersection of the rear surface of its head and a horizontal line parallel to the longitudinal centerline of the vehicle passing through the head's center of gravity is at least 50 mm (2 inches) forward of the front edge of the B-pillar. If needed, the seat back angle is adjusted, a maximum of 5 degrees, until the 50 mm (2 inches) B-pillar clearance is achieved. If this is not sufficient to produce the desired clearance, the seat is moved forward to achieve that result.

<sup>19</sup> The pole test is very similar to the proposed International Organization for Standardization (ISO) test procedure found in the ISO/TC22/SC10/WG3 draft ISO Technical Report, "Road Vehicles, Dynamic Side Impact Crash Test Procedure for Evaluating Occupant Interactions with Side Airbags for a Pole Impact Simulation" (ISO/CD 15829, February 9, 1995), with differences noted below.

this document as the “oblique pole test.”)

In the oblique pole test, when testing the driver side of the vehicle, an impact reference line would be drawn on the vehicle’s exterior where it intersects with a vertical plane passing through the head CG of the seated driver dummy at an angle of 75 degrees from the vehicle’s longitudinal centerline measured counterclockwise from the vehicle’s positive X axis as defined in S10.14 of the proposed standard. When testing the front passenger side, the impact reference line would be drawn where it intersects with a vertical plane passing through the head CG of the passenger dummy seated in the front outboard designated seating position at an angle of 285 degrees from the vehicle’s longitudinal centerline measured counterclockwise from the vehicle’s positive X axis as defined in S10.14 of the proposed standard. The vehicle is aligned so that, when the pole contacts the vehicle, the vertical center line of the pole surface as projected on the pole’s surface, in the direction of the vehicle motion, is within a surface area on the vehicle exterior bounded by two vertical planes in the direction of the vehicle motion and 38 mm (1.5 inches) forward and aft of the impact reference line. The test vehicle would be propelled sideways into the pole. Its line of forward motion would form an angle of 75 degrees (or 285 degrees) ( $\pm 3$  degrees) in the left (or right) side impact measured from the vehicle’s positive X-axis in the counterclockwise direction.

The agency tentatively concludes that the proposed oblique pole test would enhance safety because it is more representative of real-world side impact pole crashes than a 90-degree test. Frontal oblique crashes, *i.e.*, at a principal direction of force (PDOF) of 74 to 84 degrees clockwise or counter clockwise from 12 o’clock, account for the highest percentage of seriously injured (MAIS 3+) near-side occupants in narrow object crashes. However, the crash data also show that the PDOF distribution encompasses a wide range of approach angles, where the mean cumulative distribution is a 60-degree impact angle. (As discussed later in this section, a steeper angle than 75-degrees is not considered appropriate because of the need for repeatability of the test procedure.)

The oblique pole test also meets the need for safety because, unlike a 90-degree pole test, it exposes the dummy’s head and thorax to both lateral and longitudinal crash forces that are typically experienced in rear world side impacts. Weighted 1990–2001 NASS/CDS side impact data show that in

narrow object crashes, serious head and chest injuries are dominant for both small and large stature occupants. Therefore, in developing the oblique pole test procedure, the agency sought to establish a performance test that would both emulate the real world crash conditions while providing head and chest injury reduction benefits in the identified target population.

NHTSA believes that an oblique impact angle would also serve the safety need because the test is likely to result in wider inflatable head protection systems and thus protect occupants over a wider range of impacts with narrow objects. A head air bag just wide enough to meet a perpendicular pole test might not provide benefits during an oblique crash, as the head of an occupant could move laterally and forward at an angle rather than moving strictly laterally into the head air bag. For example, in a 75-degree test of a Nissan Maxima with the ES–2 dummy, the combination head/thorax side impact air bag was too small to prevent the occupant head from rotating into the pole. The HIC score was 5,254. In a 90-degree test, the same MY Maxima produced successful results, with a HIC score of 130. This contrast in results between the 75- and 90-degree tests shows up repeatedly in tests of other vehicles as well. A 1999 Volvo S–80 with an air curtain and chest air bag tested obliquely with the SID–H3 resulted in a HIC of 2,223, while a HIC of 237 was achieved in a 90-degree test.<sup>22</sup> These data are presented in more detail later in this document and in the Preliminary Economic Assessment accompanying this NPRM.

An air bag might also fail to inflate in an oblique crash if the side air bag system were closely tuned to sensing and responding in a 90-degree test using a 50th percentile male dummy. As discussed later in this preamble, data from crash tests conducted in support of this rulemaking show that side air bags in a Ford Explorer and a Toyota Camry that were certified as meeting the requirements of the 90-degree pole test of FMVSS No. 201 did not inflate at all in an oblique (75 degree) test using a 5th percentile female dummy. The HIC results for the 5th percentile female (SID–IIsFRG) dummy placed in the driver’s seats of these vehicles were in the thousands (13,125 and 8,706, respectively).

Comments are requested on NHTSA’s conclusions that combination and head

<sup>22</sup> However, that huge difference was not present in tests of the 1999 Volvo with the ES–2 dummy. Tested obliquely, the Volvo achieved a HIC of 465; in a 90-degree test, the HIC was 244.

protection air bags would generally need to be wider if the agency adopted a 75-degree vehicle-to-pole test instead of a 90-degree one, particularly if the ES–2re and SID–IIsFRG dummies were both used in testing side air bags. NHTSA believes that present seat-mounted head/thorax air bags would need to be redesigned to extend the air pocket substantially further forward toward the A-pillar to provide coverage in a 75-degree oblique test. The air bags would likely need a more robust inflation system and a larger size to reach the part of the vehicle that would be struck by the dummy’s head in a 75-degree pole test.<sup>23</sup>

In contrast, side curtains might not need to be substantially widened to meet an oblique pole test. The agency believes that most current side air curtains are tethered to the A- and C-pillars of vehicles and generally would need less redesign than seat-mounted bags to meet an oblique pole test. Air curtains might thus be the countermeasure chosen by many manufacturers to meet the vehicle-to-pole test requirements proposed today.

In addition, after evaluating research conducted on a number of HPS, the agency has determined that air curtain systems could be effective in preventing or reducing complete and partial occupant ejection through side windows. “Rollover Ejection Mitigation Using Inflatable Tubular Structures,” Simula, *et al.*, 1998; “Status of NHTSA’s Ejection Mitigation Research Program,” Willke, *et al.*, ESV 2003. This is important because the fatality rate for an ejected vehicle occupant is three times as great as that for an occupant who remains inside of the vehicle.

The best way to reduce complete ejection is for occupants to wear their safety belts. However, of the 5,400 ejected fatalities through front side windows, 2,200 are from partial ejections. Fatal injuries from partial ejection can occur even to belted occupants,<sup>24</sup> when their head protrudes outside the window and strikes the ground in a rollover or even the striking object (*e.g.*, pole or a taller vehicle hood) in a side impact.

While the cumulative distribution of the angle of approach of near-side

<sup>23</sup> Simply using a 5th percentile female dummy in addition to a 50th percentile male dummy in a 90-degree pole test might not result in seat-mounted head/thorax bags being wider. The two dummies would be positioned fore-and-aft and horizontally at different places in the vehicle. However, if the HPS were seat-mounted, the seat-mounted HPS would travel along the seat track with the dummies. That HPS could be tuned to a 90-degree pole test and not provide benefits in an oblique impact.

<sup>24</sup> About 60 percent of the partial ejections occurred to belted occupants.

narrow object crashes has a mean of 60 degrees, based on its research, the agency has concluded that the 75-degree impact is repeatable to simulate in a laboratory test while a 60-degree impact is not. The more oblique the angle is, as measured from the lateral direction (*e.g.*, 30 degrees for the 60-degree impact versus 15 degrees for the 75-degree impact from the longitudinal direction), the more difficult it is to control dummy head and/or body kinematics (specifically, direction of the dummy head motion). For more oblique angles (as measured from the lateral direction), at the initial pole-to-vehicle contact, the lateral distance from the centerline of the pole to the head center of gravity is larger, and more of the vehicle structure, specifically the seat, is involved in that crush space. Different seat designs and structural attachments to the vehicle body could produce inconsistent dummy readings because of the varying dummy head/body kinematics and the head not consistently contacting the approaching 254 mm (10-inch) pole.

Comments are requested on the appropriateness and practicability of using the 75-degree angle of approach as well as the 90-degree impact angle now used in the optional pole test of FMVSS No. 201.

### 3. Positioning the Seat and Impact Reference Line

*50th percentile male dummy.* In the oblique pole test, an impact reference line would be placed on the exterior of the vehicle at the intersection of the vehicle exterior and a 75-degree (or 285-degree, for front passenger side) vertical plane passing through the center of gravity of the head of the driver (or passenger) dummy seated in the front outboard designated seating position. The 50th percentile male test dummy and the front vehicle seat would be positioned along the seat track as the dummy and front seat are positioned in the MDB test of FMVSS No. 214. (As noted below, the agency is also considering positioning the dummy and vehicle seat along the seat track using the FMVSS No. 201 seating procedure.) Under the FMVSS No. 214 procedure, the vehicle seat is positioned mid-track fore-and-aft. (This provision would only apply to the front seat, as the pole test would not apply to the rear seat.)

NHTSA test data indicate that the FMVSS No. 201 and FMVSS No. 214 seating procedures can result in different HIC measurements when using the SID-H3 dummy (see Table 4, *infra*). When a 1999 Volvo S-80 was tested in an oblique pole test with a SID-H3 50th percentile dummy, the HIC was 2,213 when the FMVSS No. 201 seating

position was used, as opposed to 395 when the FMVSS No. 214 seating position was used. The side air bag system in the Volvo was an air curtain and thorax bag. Similarly, when a 2000 Saab was tested obliquely with the SID-H3 50th percentile male dummy, the HIC was 5,155 using the FMVSS No. 201 seating procedure, as opposed to 182 using the FMVSS No. 214 seating position. The Saab's side air bag system was a combination bag. Compared to the FMVSS No. 201 seating position, the FMVSS No. 214 seating position can place the dummy rearward and closer to the B-pillar. Since the production side air bag system was wide enough to cover the dummy head trajectory in this seating position, the HIC values were significantly lower in these oblique tests.

However, when the ES-2re dummy was used, differences in HIC were not so pronounced. The HIC score for the 1999 Volvo S-80 was 465 when using the FMVSS No. 201 procedure, as opposed to 329 when the dummy was seated according to FMVSS No. 214 seating specifications. The HIC for the Saab was 243 using FMVSS No. 201 seating procedure, and 171 using the FMVSS No. 214 procedure. The difference between the results of the two dummies is due to small differences in the dummy head/neck/shoulder kinematics and the tuning of current head protection air bag systems to provide limited coverage in lateral impacts. In both the Volvo S-80 and the Saab oblique pole tests with the ES-2, the deploying air bag lifted the articulated arm upward and inboard and the head bent laterally and contacted the bag along a main air chamber. In the case of the two oblique pole tests with the SID-H3, the dummy had rotated slightly forward and contacted the bag systems at a more forward section, resulting in contact with the intruding pole in the case of the Saab. It is also noted that air curtains are currently designed for the FMVSS No. 201 pole test, in which the SID-H3 dummy is used. In some cases, the air curtain might not be large enough to provide coverage to the SID-H3 dummy in an oblique crash.

Rib deflection measurements differed slightly when the different seating positions prescribed in FMVSS No. 201 and No. 214 were used in the Volvo. Rib deflections were 40.70 mm (1.6 in) and 48.6 mm (1.91 in) when the FMVSS Nos. 201 and 214 procedures, respectively, were used. (The 48.6 mm rib deflection value obtained when the FMVSS No. 214 procedure was used would not meet this NPRM's proposed criterion of 44 mm.) Chest deflections

did not differ significantly in the Saab in dummies positioned according to the FMVSS No. 201 and FMVSS No. 214 procedures (49.9 mm (1.96 in) versus 49.4 mm (1.94 in)).

We have tentatively decided to use the FMVSS No. 214 seating procedure for the vehicle-to-pole test proposed today. The FMVSS No. 201 procedure is appropriate for that standard's pole test in order to place the SID-H3's head in the window opening, thus ensuring contact with a deploying head air bag and eliminating head interaction with the B-pillar.<sup>25</sup> In the context of FMVSS No. 201, isolating the head air bag in this manner evaluates the effectiveness of the head air bag, which accords with the goal of that standard. An air bag in FMVSS No. 201, though optional, would provide more protection than any interior component protected by padding or other energy-absorbing material. However, an air bag designed to meet the current proposal would offer more protection over a larger area and therefore, is expected to be more effective and yield more safety benefits than the air bags offered under the optional pole test requirement in FMVSS No. 201.

Using the FMVSS No. 214 seating procedure has certain advantages when used in the oblique pole test. First, many mid-size occupants might use the mid-track position more typically than the one closer to the steering wheel specified under FMVSS No. 201. Second, using the FMVSS No. 214 procedure positions the 50th percentile male dummy further back towards the B-pillar than the FMVSS No. 201 seating procedure. By having the 50th percentile male dummy sitting at that position and the 5th percentile female dummy sitting full forward, the agency can ensure a test of as wide an area as possible. The agency believes that rearward positioning of the 50th percentile male dummy and the much further forward seat position for the 5th percentile female dummy (and the lower position of the 5th percentile female dummy's head) would result in head air bag designs that provide head protection through much or all of the window opening area. For these reasons, the agency is proposing to use the FMVSS No. 214 seating procedure for the 50th percentile male dummy in the oblique pole test. The agency seeks comments on which seating position (FMVSS No. 201 versus No. 214) is appropriate.

<sup>25</sup> While the shoulder of the SID-H3 could interfere with the chest reading in the perpendicular test, FMVSS No. 201 does not specify chest injury criteria.

5th percentile female dummy. The procedures for determining the impact reference line for the test using the 5th percentile female dummy would be similar to that discussed above for determining the line when using the male dummy.

Dummy positioning would differ, in that the female dummy would be positioned in the vehicle seating position in the manner described in S16.3.2 to S16.3.5 of FMVSS No. 208. That is, the dummy would be seated with the seat track in the full forward position. The agency tentatively concludes that a properly designed inflatable system should and can provide protection in that location.

#### b. Dummies and Injury Criteria

##### 1. 50th Percentile Male Dummy (ES-2re)

Crash data indicate that the 50th percentile male dummy is generally representative of the height and weight of occupants injured in collisions with passenger vehicles and with narrow objects.<sup>26</sup> The median height and weight of the injured occupants in crashes with passenger cars (on the struck side of a vehicle) are 1,701 mm (67 inches) and 72.1 kg (159 lb), and 1,701 mm (67 inches) and 71.2 kg (159.5 lb) in collisions with LTVs. The median height and weight of the injured occupants in crashes with narrow objects are 1,715 mm (67.5 inches) and 72.3 kg (159.5 lb). Nearly 59 percent of all MAIS 3+ injuries occurred to occupants in the medium height stature category.

As noted earlier, there are now improved test dummies that represent the 50th percentile male better than the SID. In 2000, NHTSA granted in part a petition for rulemaking from the AIAM, the Insurance Institute for Highway Safety, and the organization then called the American Automobile Manufacturers Association. The petitioners asked NHTSA to examine replacing the SID with an enhanced side impact dummy (see section IV(i), above). The petitioners suggested that

<sup>26</sup> NHTSA analyzed 1991–2000 NASS cases involving (1) AIS 3 and greater injured occupants in near side impacts, (2) non-rollover tow-away side crashes without complete ejections, and (3) occupants with a height of 1,422 mm (56 inches) or greater. There were a total of 1,965 cases: 1,073 male occupants, 891 female occupants, and one with unknown gender. The injury distribution was 775 fatalities and 1,190 seriously injured. These cases were annualized to national estimates. The analysis was performed with respect to three parameters—(1) gender (male and female), (2) body heights (short, medium, and tall categories), and (3) MAIS 3 and greater injured body regions (head, chest, abdomen, and others). (“Medium height” was the middle of all occupant height/weight as studied.)

NHTSA replace the SID with a test dummy (EuroSID–1) used in a European side impact standard (EU/96/27/EC). Although the agency concluded that EuroSID–1 had problems in measuring chest deflections accurately because of “flat topping” of responses, which rendered it unsuitable for use in FMVSS No. 214, we granted this part of the petition because we anticipated that the problems could be cured and that a dummy technically superior to the SID could be incorporated into FMVSS No. 214. (“Flat topping” refers to sustained peaks (plateaus of flat-tops) in plots of the dummy’s rib displacements over time. NHTSA observed sustained peaks as long as 15 milliseconds in rib displacement curves in tests using the EuroSID–1. “Comparative Performance Testing of Passenger Cars Relative to FMVSS 214 and the EU 96/EC/27 Side Impact Regulations: Phase 1”, Samaha et al, Paper No. 98–S8–O–08, 16th International Technical Conference on the Enhanced Safety of Vehicles, Windsor, Canada 1998. Rib deflection flat tops were deemed to be of concern, especially at low levels of deflection, as they can be an indication that the rib deflection mechanism is binding and thus the thorax is not responding correctly to the load from the intruding side structure. Accordingly, the resulting peak deflections would be of questionable usefulness as injury indicators.) Users of the dummy in Europe subsequently determined that the EuroSID–1 design allowed a spurious load path through the back plate in the dummy and thus transferred chest loads through the back plate, giving erroneous chest deflection readings.

The problems of the EuroSID–1 appear to have been eliminated with the evolution of the dummy into the ES–2 side impact dummy and the subsequent changes made with respect to the ES–2’s rib design. The ES–2re dummy is more biofidelic than SID and offers more injury measurement capabilities than the present side impact dummy. Thus, using this improved dummy would enhance the protection afforded by vehicles to the affected population, especially those represented by a 50th percentile male dummy.<sup>27</sup>

<sup>27</sup> The Alliance of Automobile Manufacturers, the Association des Constructeurs Europeens d’Automobiles and the Japan Automobile Manufacturers Association wrote an October 16, 2002 letter to NHTSA urging the agency to “actively participate in the final development of WorldSID with the intention of specifying this device in a future upgrade to FMVSS 214.” NHTSA supports the continuous improvement of test dummies. However, the agency will not delay this rulemaking to wait for the WorldSID. In the agency’s best estimate, it will take a considerable amount of time

#### A. Background

The ES–2 dummy evolved from the EuroSID and EuroSID–1 dummies. EuroSID existed when NHTSA adopted the dynamic moving deformable barrier test into FMVSS No. 214 in 1990. However, when the agency examined the dummy, NHTSA determined that EuroSID suffered from a number of technical problems involving “flat topping,”<sup>28</sup> biofidelity, reproducibility of results, and durability. Because of these limitations, in 1988 NHTSA decided against adopting EuroSID and instead adopted SID as the test device used in the dynamic FMVSS No. 214 test.

The EuroSID was developed in the 1980s, and a revised version known as EuroSID–1 is currently specified as the test dummy to be used in ECE Regulation No. 95 and European Union (EU) Directive 96/27/EC (hereinafter EU 96/27/EC) for side impact testing. As noted above, in 1996, Congress asked NHTSA to consider whether the dynamic side impact provisions of the European side impact regulation, including those specifying use of the EuroSID–1 dummy, were at least functionally equivalent to those in FMVSS No. 214. NHTSA developed and provided Congress with its side impact harmonization plan<sup>29</sup> that set forth

to complete the evaluation of the WorldSID for its usefulness in vehicle tests, to determine its ability to project the risk of occupant injury, and to implement its use into FMVSS No. 214 compliance testing. In contrast, based on worldwide use experience of the EuroSID–1 and considerable experience with the ES–2, the rulemaking to incorporate the ES–2re dummy into Part 572 can be initiated in 2004. Since the dummy is available now for use in side impact testing, we estimate that the ES–2re could serve the need for an upgraded anthropomorphic test device (ATD) until the final development and implementation of the WorldSID. This assumes, of course, that WorldSID would ultimately be found to be suitable for use in FMVSS No. 214 and that the agency would decide through notice-and-comment rulemaking that its use in compliance testing is appropriate.

<sup>28</sup> The preamble to NHTSA’s final rule adopting its current side impact dummy (SID) noted that the agency found that the EuroSID dummy had problems with flat topping. The agency stated, “[o]ne of the problems discovered in NHTSA’s EuroSID sled tests was that the ribs were bottoming out, which may have invalidated the V\*C measurements being made. This condition was characterized by a flat spot on the displacement-time history curve, while the acceleration-time history curve showed an increase with time until the peak g was reached. Although considerable attempts were made to correlate V\*C and TTI(d), the deflection data collected continue to be questionable.” 55 FR 45757, 45765 (October 30, 1990).

<sup>29</sup> “Report to Congress: NHTSA Plan for Achieving Harmonization of the U.S. and European Side Impact Standards,” April 1997; “Report to Congress: Status of NHTSA Plan For Side Impact Regulation Harmonization and Upgrade,” March 1999. NHTSA Docket No. 1998–3935–1 and – 10 of the DOT Docket Management System at [www.dms.dot.gov/](http://www.dms.dot.gov/).

NHTSA's planned research to evaluate the functional equivalence of the two standards and later, by update, the results of that research. NHTSA performed a series of crash tests of FMVSS No. 214 compliant vehicles using the EU test procedures and the EuroSID-1 dummy.

A main finding was that in all tests conducted, data for dummy rib deflections indicated flat topping. With flat topping, the resulting rib deflections and the V\*C computations,<sup>30</sup> which are based on the rib deflection, are suspect. Due to this anomaly and others in the measurements obtained with the European dummy, the agency determined that it was not possible to generate the data necessary to determine whether the European standard and its requirements are at least functionally equivalent to the provisions in FMVSS No. 214. The data did show, however, that the EuroSID-1 dummy was not suitable for use in FMVSS No. 214.

Since that time, the EuroSID line of dummies has made steady progress toward resolving these issues, with the ES-2re being the latest version. The ES-2 was designed to overcome the concerns raised by NHTSA and users of the dummy worldwide.<sup>31</sup> Beyond flat topping, concerns had been raised about the projecting back plate of the dummy grabbing into the seat back, upper femur contact with the pubic load cell hardware, binding in the shoulder assembly resulting in limited shoulder rotation, and spikes in the pubic symphysis load measurements associated with knee-to-knee contact. To address these concerns, the dummy manufacturer installed hardware upgrades in the ES-2, including an improved rib guide system in the thorax, a curved and narrower back plate, a new attachment in the pelvis to increase the range of upper leg abduction and inclusion of rubber buffers, a high mass flesh system in the legs, and beveled edges in the shoulder assembly.

The ES-2's back plate continued to grab the seat back in some of NHTSA's tests, despite the dummy manufacturer's initial efforts to address the problem by reducing the size and shape of the back plate. The dummy manufacturer was able to solve the flat topping problem by redesigning the rib module. The back plate problem was solved by adding rib

extensions, *i.e.*, replacement ribs that extend from the lateral portion of the non-struck thorax, around the sternum and struck-side, and end at the posterior aspect of the spine. The extended ribs provide a continuous loading surface that nearly encircles the thorax and enclose the posterior gap of the ES-2 ribcage. According to NHTSA's test data, these "rib extensions" reduce to a great extent the back plate grabbing force that had the effect of lowering rib deflection responses in tests. The rib extensions also do not appear to affect the dummy's rib deflection responses in tests in which high back plate loads did not occur.

The ES-2 dummy has not yet supplanted the EuroSID-1 dummy in Europe or elsewhere for use in regulations as of this time. However, based on a proposal from the Netherlands, the UN/ECE's Working Party on Passive Safety (GRSP) has recommended to the WP.29 that ECE Regulation No. 95 be amended to use the ES-2 dummy in place of the EuroSID-1.<sup>32</sup> The GRSP's proposal takes into account the modifications that NHTSA has done to ES-2 to fix the back plate problem, as well as other minor outstanding technical problems raised by other participants. If this is adopted, the European Union is expected to also amend its Directive 96/27/EC to use the ES-2 dummy.

Using the ES-2re in FMVSS No. 214 would also accord with the practices of the non-governmental European New Car Assessment Program (EuroNCAP) on side impact. EuroNCAP began using the ES-2 dummy with the injury criteria specified in EU 96/27/EC in February 2003.

In light of the above modifications and the anticipated benefits of this dummy, NHTSA believes that the ES-2re merits consideration for

incorporation into Part 572 and for use in FMVSS No. 214 testing. Based upon the ES-2re's superior biofidelity and added measurement capabilities for injury assessment of many body regions and associated instrumentation, we have tentatively decided that the ES-2re is the preferred option for the 50th percentile male dummy. As part of a separate rulemaking action, NHTSA is currently in the process of "Federalizing" the ES-2re dummy. A technical report and other materials describing the ES-2re in detail have been placed in the Docket for today's NPRM. A proposal to incorporate the specifications for the ES-2re in Part 572 will be published shortly in the **Federal Register**.

*Biofidelity, Repeatability and Reproducibility.* Biofidelity is a measure of how well a test device duplicates the responses of a human being in an impact. The Occupant Safety Research Partnership and Transport Canada conducted biomechanical testing on the ES-2 dummy. Byrnes, *et al.*, "ES-2 Dummy Biomechanical Responses," 2002, Stapp Car Crash Journal, Vol. 46, p. 353. Biomechanical response data were obtained by completing a series of drop, pendulum, and sled tests from the International Organization of Standardization (ISO) Technical Report 9790. Full scale tests were also conducted. For the ISO rating system, a dummy with a higher biofidelity rating responds much more like a human subject. The overall dummy biofidelity rating was determined to be "fair," at 4.6, an improvement over the SID and Eurosid-1 (which received ratings classifications of 2.3 and 4.4, respectively).

The agency also used the biofidelity ranking system developed by Rhule, *et al.*, "Development of a New Biofidelity Ranking System for Anthropomorphic Test Devices," 2002, Stapp Car Crash Journal, Vol. 46, p. 477. The assessment included the dummy's External Biofidelity (how much like a human the dummy loads the vehicle components) and Internal Biofidelity (how much like a human the dummy measures injury criteria measurement responses and is calculated for those body regions that have an associated injury criterion). The Overall External and Internal Biofidelity ranks are an average of each of the external and internal body region ranks, respectively. A lower biofidelity rank indicates a more biofidelic dummy. A dummy with an External Biofidelity rank of less than 2.0 responds much like a human subject. The ES-2re dummy had an Overall External Biofidelity rank of 2.6, compared to 2.7 for the ES-2 and

<sup>30</sup> V\*C, viscous criterion, is another way of measuring thoracic injury. It is based upon the product of chest compression and the rate of compression.

<sup>31</sup> On March 11, 2002, Nissan made a presentation to NHTSA on sled test results that Nissan believed showed back plate loading in the ES-2. Docket NHTSA-99-7381.

<sup>32</sup> The UN/ECE World Forum for Harmonization of Vehicle Regulations (WP.29) administers several agreements relating to the global adoption of uniform technical regulations. An agreement, known as the 1958 Agreement, concerns the adoption of uniform technical prescriptions for wheeled vehicles, equipment and parts and the development of motor vehicle safety regulations for application primarily in Europe. UN-member countries and regional economic integration organizations set up by UN country members may participate in a full substantive capacity in the activities of WP.29 by becoming a Contracting Party to the Agreement. Various expert groups (*e.g.*, the GRSP) within WP.29 make recommendations to WP.29 as to whether regulations should be adopted by the Contracting Parties to the 1958 Agreement. Under the 1958 Agreement, new Regulations and amendments to existing Regulations are established by a vote of two-thirds majority of Contracting Parties. The new Regulation or amendment becomes effective for all Contracting Parties that have not notified the Secretary-General of their objection within six months after notification.

3.8 for the SID-H3. Its overall internal biofidelity rank was 1.6.

The ES-2re dummy's repeatability and reproducibility were determined on the basis of component tests and sled tests of the two dummies. The component tests were conducted on head, neck, shoulder, upper rib, middle rib, lower rib, abdomen, lumbar spine and pelvis body regions. The repeatability assessment was made in terms of percent CV (Coefficient of Variance). A CV value of less than 5 percent is considered excellent, 5-8 percent good, 8-10 percent acceptable, and above 10 percent unacceptable. Nine tests were performed with one of the dummies, and 7 tests were performed with the other. The reproducibility was established by comparing the average responses of both dummies. The reproducibility assessment was made in terms of response differences between the two dummies with respect to the mean. A difference of less than 5% is considered excellent, 5-8% good, 8-10% acceptable, and above 10% unacceptable. The results of the tests indicate "excellent" repeatability and reproducibility ratings for all components except for the pelvis, which has a "good" rating. For a complete discussion of these tests, interested persons should consult the technical paper entitled "Technical Report—Design, Development and Evaluation of the ES-2re Side Crash Test Dummy," which has been placed in the agency's docket.

## B. Injury Criteria

In assessing the suitability of a dummy for side impact testing, it is necessary to consider its injury assessment capabilities relative to human body regions at risk in the real world crash environment. Crash data indicate that FMVSS No. 214 should encourage vehicle designs that protect not only an occupant's head, but also other body regions in the vehicle-to-pole test. Accordingly, injury criteria are being proposed for the head, thorax, abdomen, and pelvis. A technical report titled, "Injury Criteria for Side Impact Dummies," and the agency's Preliminary Economic Assessment for this NPRM, have a full discussion of these injury criteria and supporting data. (Both documents are available in the docket.)

The types of injury criteria proposed by NHTSA are generally consistent with those developed by ECE/WP.29, by the European Union in its directive EU 96/27/EC, and by EuroNCAP for rating vehicles, although some may differ, based upon the results of NHTSA

testing. Four of NHTSA's proposed injury criteria are specified in EU 96/27/EC for use with the EuroSID-1 dummy. NHTSA has tentatively decided not to use the chest viscous injury criteria,  $V^*C \leq 1.0$ . NHTSA has not found the  $V^*C$  criterion to be repeatable and reproducible in the agency's research.

While the ES-2 is an upgraded EuroSID-1 dummy, rather than an entirely new dummy, we have concluded that the thorax of the ES-2 is so different from that of the predecessor dummy that previously-generated EuroSID-1 data should not be considered in analyzing the ES-2 and its associated thoracic injury criteria. The flat topping and other problems of the EuroSID-1 make those earlier data of little value to researchers in analyzing the ES-2. Consequently, in developing the criteria discussed below, NHTSA limited its analysis to existing ES-2 data and our own research conducted with the ES-2re. The agency believes that these two data sets are interchangeable, except for ES-2 data affected by the back plate problem. Based upon our assessment of these dummies, we believe that the ES-2 with rib extension modifications is superior to the unmodified version. Accordingly, the agency is proposing use of the ES-2re with the following injury criteria.

**Head:** NHTSA is proposing to require passenger cars and LTVs to limit HIC to 1000 (measured in a 36 millisecond time interval) when the ES-2re dummy is used in the proposed 32 km/h (20 mph) oblique vehicle-to-pole test (and the MDB test). This measure has been chosen because the HIC<sub>36</sub> 1000 criterion is consistent with the optional pole test designed to afford head protection under FMVSS No. 201. The HIC<sub>36</sub> 1000 criterion provides a measure with which the agency and the industry already have experience. HIC<sub>36</sub> 1000 relates to a 52 percent risk of AIS 3+ injury.

**Thorax (Chest):** NHTSA has proposed two criteria to measure thoracic injury when using the ES-2re. First, chest deflection shall not be greater than 42 mm (1.65 in) for any rib (reflecting an approximate 50 percent risk of an AIS3+ injury). We note that our proposed requirement is harmonized with the EU regulation for the EuroSID-1.<sup>33</sup>

<sup>33</sup>Based on an analysis of the limited thoracic force-deflection cadaver data available in the 1980's, the U.S. Advisory Group of Working Group 6 of ISO indicated that a rib-to-spine deflection of 42 mm would correspond to a 50 percent risk of nine rib fractures. According to Dr. Terriere from Renault, internal organ injuries and flail chest (AIS 4) would be more likely to occur if the number of rib fracture became higher than nine. Dr. Terriere indicated that we could exclude severe internal organ injuries by excluding the AIS 4 flail chest injury. Based on that reason, European groups

However, the agency is also considering, and seeking comment on, an alternative chest deflection criterion within the range of 35-44 mm (1.38-1.73 in). This range corresponds to an approximate 40-50 percent risk of AIS3+ injury. Second, resultant lower spine acceleration shall not be greater than 82 g's (reflecting a 50 percent risk of an AIS3+ injury).

The agency believes that a combination of the two criteria is appropriate to provide thoracic injury protection to vehicle occupants. NHTSA tentatively selected these two criteria based upon a series of 42 side impact sled tests using fully instrumented human cadaveric subjects and 16 sled tests using the ES-2re conducted at the Medical College of Wisconsin. NHTSA conducted the analysis using logistic regression with injury outcome in cadaveric sled tests as the response, and ES-2 dummy measured physical parameters (maximum rib deflections, TTI, maximum spinal accelerations) in similar sled tests as the covariates. The subjects' anthropometric data such as age, gender, and mass were also included as covariates since the agency believed that they might influence injury outcome.<sup>34</sup> This method of analysis provided injury criteria that can directly be applied to the ES-2re dummy.

Chest deflection has been shown to be the best predictor of thoracic injuries in low-speed crashes. We believe it to be a better injury risk measure than TTI(d) for the ES-2re dummy.<sup>35</sup> We added spinal acceleration criteria because we believe that there might be injurious loading conditions that are not picked up by the rib deflections measured on the ES-2re dummy, and spinal accelerations are a good measure of the overall load on the thorax. The

concluded that the EuroSID-1 should be based on the risk of rib fractures and thus a rib deflection  $\leq 42$  mm. It should be pointed out that the said rib deflection criterion is a cadaver-based injury criterion for lower AIS level injuries, and that no transformation was made between the EuroSID-1 and the cadaver test data.

<sup>34</sup>Kuppa, S., Eppinger, R., McKoy, F., Nguyen, T., Pintar, F., Yoganandan, Y., "Development of Side Impact Thoracic Injury Criteria and Their Application to the Modified ES-2 Dummy with Rib Extensions (ES-2re), Stapp Car Crash Journal, Vol. 47, October, 2003.

<sup>35</sup>TTI(d), a chest acceleration-based criteria, when combined with anthropometric data, was developed by NHTSA (Eppinger, R. H., Marcus, J. H., Morgan, R. M., (1984), "Development of Dummy and Injury Index for NHTSA's Thoracic Side Impact Protection Research Program," SAE Paper No. 840885, Government/Industry Meeting and Exposition, Washington, DC; Morgan, R. M., Marcus, J. H., Eppinger, R. H., (1986), "Side Impact—The Biofidelity of NHTSA's Proposed ATD and Efficacy of TTI," SAE Paper No. 861877, 30th Stapp Car Crash Conference) and is included in the FMVSS No. 214 side impact protection standard.

acceleration at the lower spine ("lower spine acceleration") is also a measure that is less sensitive to direction of impact. Consequently, in concert, the two thoracic criteria will enhance injury assessment in a vehicle side crash test, and we expect them (and their associated reference values) to result in reduced chest injuries as compared to the criteria in the current standard.

While we have tentatively selected 42 mm as the deflection criterion, we are also considering a chest deflection limit within the range of 35–44 mm (1.38–1.73 in). NHTSA reanalyzed the Eppinger data set that was used when NHTSA undertook the rulemaking adopting the MDB test into FMVSS No. 214 in 1990 (see preceding footnote concerning TTI(d)). The agency analyzed the injury risk curve versus TTI(d) and estimated that a rib deflection of 44 mm (1.73 in) for the ES-2re would be approximately equivalent to a TTI(d) of 85 g's for the SID.<sup>36</sup> (A TTI(d) limit of 85 g's is specified in the MDB test of FMVSS No. 214 for 4-door vehicles.) The 44 mm (1.73 in) value corresponds to a 50 percent risk of injury for a 45-year-old occupant.<sup>37</sup> Data from NASS indicates that chest is still the predominant seriously injured body region and that serious chest injuries are prevalent in the modern vehicle fleet. A deflection limit of 35 mm, reflecting a 40 percent risk of an AIS 3+ injury, could markedly improve the chest protection afforded by FMVSS No. 214.

The proposed limit for resultant lower spine acceleration would be 82 g. The upper and lower spine of the ES-2re are instrumented with tri-axial accelerometers (x, y, and z direction corresponding to anterior-posterior, lateral medial, and inferior-superior). In purely lateral loading, one would expect only lateral (y) accelerations. Moreover, due to constraints built into their designs, the dummies exhibit predominantly y (lateral) acceleration due to lateral loading. In the side impact sled tests at the Medical College of Wisconsin (MCW), described above, the

dummy's lower spine accelerations were almost the same as the resultant acceleration ( $\sqrt{x^2+y^2+z^2}$ ) since x and z accelerations are small. However, due to the complex response of humans, vehicle occupants experience x, y, z accelerations even in pure lateral loading. In vehicle crashes, loading can be in various directions. Therefore, NHTSA believes that to account for overall loading, resultant accelerations should be considered rather than lateral acceleration alone.

**Abdomen:** The ES-2re dummy offers abdominal injury assessment capability, a feature that is not present in the SID dummy. The agency is proposing an abdominal injury criterion of 2,500 Newtons (N) (562 pounds). We note that our proposed requirement is harmonized with the abdominal load injury criterion used in the European side impact regulation, EU 96/27/EC, as well as the EuroNCAP Program for the EuroSID-1. However, the agency is also considering, and seeking comment on, an alternative abdominal injury criterion within the range of 2,400–2,800 N (540–629 pounds). This range corresponds to an approximate 30–50 percent risk of AIS 3+ injury. The proposed abdominal injury criterion was developed using cadaver drop test data from Walfisch, *et al.* (1980).<sup>38</sup> Analysis of this data indicated that applied force was the best predictor of abdominal injury, and an applied force of 2,500 N (562 pounds) corresponds to a 33 percent risk of AIS 3+ injury. The MCW sled test data indicated that the applied abdominal force on the cadavers was approximately equal to the total abdominal force in the ES-2re dummy under similar test conditions.

This abdominal capability of the ES-2re is a potentially significant advantage over the SID dummy, and requiring vehicles to satisfy this injury criterion to meet FMVSS No. 214 might reduce the number of abdominal injuries to the driving population. In a NASS study of side impact crashes, it was estimated that between 8.5 percent and 21.8 percent of all AIS 3+ injuries are to the abdomen of restrained near side front seat occupants.<sup>39</sup> The SID dummy

currently used in FMVSS No. 214 does not have these detection capabilities, thus leaving a gap in the control of injury outcomes in side crashes.

**Pelvis:** NHTSA is proposing a pelvic force limit of not greater than 6,000 N (1,349 pounds) (25 percent risk of AIS3+ injury). The ES-2re has two pelvic measurement capabilities. First, the ES-2re has instrumentation to measure pelvic acceleration, as does the SID dummy. However, unlike the SID, the ES-2re is also capable of measuring the force (load) at the pubic symphysis, which is the region of the pelvis where the majority of injuries occur. A field analysis of 219 occupants in side impact crashes by Guillemot, *et al.* (1998) showed that the most common injury to the pelvis was fracture of the pubic rami (pelvic ring disruption).<sup>40</sup> Pubic rami fractures are the first to occur because it is the weak link in the pelvis.

This NPRM would only limit pubic symphysis force. The agency is not proposing an acceleration-based criterion because the agency believes that an injury threshold limit on pelvic acceleration is dependent on the impact location and the type of loading (distributed versus concentrated). Therefore, pelvic acceleration is not as good a predictor of pelvic fracture as force. The scientific literature has documented that force alone is a good predictor of pelvic injury.<sup>41</sup> Further, the pubic symphysis load injury criterion has been applied in the European side impact regulation EU 96/27/EC as well as the EuroNCAP Program, so there is experience with this measure and some demonstration of its usefulness. The criterion in those programs is 6,000 N (1,349 pounds), the same limit that we are proposing here.

The proposed injury criteria and limits are summarized below in Table 2:

Procedures," Proceedings of the 18th Enhanced Safety of Vehicles (ESV) Conference (2003).

<sup>40</sup> Guillemot H., Besnault B., Robin, S., *et al.*, "Pelvic Injuries In Side Impact Collisions: A Field Accident Analysis And Dynamic Tests On Isolated Pelvic Bones," Proceedings of the 16th ESV Conference, Windsor (1998).

<sup>41</sup> Bouquet, *et al.* (1998) performed cadaver pendulum impact tests and showed that the pubic symphysis load cell in the EuroSID-1 dummy was a good predictor of pelvic fracture. See Bouquet, R., Ramet, M., Bermond, F., Caire, Y., Talantikite, Y., Robin, S., Voiglio, E., "Pelvis Human Response to Lateral Impact," Proceedings of the 16th Enhanced Safety of Vehicles (ESV) Conference (1998).

<sup>36</sup> Kuppa, S., Eppinger, R., McKoy, F., Nguyen, T., Pintar, F., Yoganandan, Y., "Development of Side Impact Thoracic Injury Criteria and their Application to the Modified ES-2 Dummy with Rib Extensions (ES-2re), Stapp Car Crash Journal, Vol. 47, October, 2003.

<sup>37</sup> Logistic regression analysis using cadaver injury and anthropometry information along with the ES-2 measurements indicate that the age of the subject at the time of death had a significant influence on the injury outcome ( $p < 0.05$ ). *Id.*

<sup>38</sup> Walfisch, G., Fayon, C., Terriere, J., *et al.*, "Designing of a Dummy's Abdomen for Detecting Injuries in Side Impact Collisions, 5th International IRCOBI Conference, 1980.

<sup>39</sup> Samaha, R.S., Elliot, D., "NHTSA Side Impact Research: Motivation for Upgraded Test

TABLE 2.—PROPOSED INJURY CRITERIA FOR ES–2RE

Criterion	HIC <sub>36</sub>	Rib-Def. (mm)	Lower spine (g)	Abd.-force (N)	Public-force (N)
Proposed Limits	1,000	* 35–44	82	* 2,400–2,800	6,000

\* A particular value within this proposed range would be selected.

C. Oblique Pole Tests With ES–2 and ES–2re

NHTSA has conducted four 32 km/h (20 mph) oblique pole tests using the

FMVSS No. 214 seating procedure and the ES–2re dummy. The agency has conducted five additional tests using the FMVSS No. 201 seating procedure. The

first four tests were with the ES–2 dummy and the fifth test was with the ES–2re dummy. The test results are presented in Table 3.

TABLE 3.—75-DEGREE POLE TEST RESULTS ES–2 DUMMY OR ES–2RE DUMMY (USING FMVSS NO. 214 SEATING POSITION)

Test vehicle	Restraint *	HIC <sub>36</sub>	Rib-def (mm)	Lower spine (g)	Abd.- force (N)	Public-force (N)
<b>Using FMVSS No. 214 seating position</b>						
Proposed limits		1,000	35–44	82	2,400–2800	6,000
1999 Volvo S80 **	AC+Th	329	48.7	51.2	1,550	1,130
2000 Saab 9–5 **	Comb	171	49.4	49.0	1,370	1,730
2004 Honda Accord **	AC+Th	446	30.7	51.7	1,437	2,463
2004 Toyota Camry **	AC+Th	452	43.4	52.5	1,165	1,849
<b>Test Results Using FMVSS No. 201 Seating Position</b>						
1999 Nissan Maxima	Comb	5,254	35.7	45.1	1,196	2,368
1999 Volvo S80	AC+Th	465	40.7	51.4	1,553	1,700
2000 Saab 9–5	Comb	243	49.9	58.3	1,382	2,673
2001 Saturn L200	AC	670	52.3	78.2	1,224	2,377
2002 Ford Explorer **	AC	629	43.0	98.4	2,674	2,317

\* Comb.=combination head/chest SIAB; AC=air curtain; Thorax or Th=chest SIAB

\*\* Test was conducted with the ES–2re dummy.

Table 3 shows that vehicles with air curtain systems performed well in protecting the dummy’s head. The head/chest side air bag of the 2000 Saab 9–5 also passed the limit on HIC. However, the head/chest side air bag of the 1999 Nissan Maxima did not perform well (the HIC score was 5,254).

The agency’s tests of the Maxima illustrate how the impact angle of the pole test can influence the level of protection provided by a vehicle’s side air bags. NHTSA conducted three oblique pole tests using a Maxima without a side bag for the purpose of demonstrating test repeatability of the oblique pole test procedure. As previously mentioned, the HIC score for a Maxima vehicle with a head/chest side impact air bag was 5,254 (results presented in Table 3, above), while the HIC scores for Maxima cars without a side air bag head protection system ranged from 11,983 to 15,591. Although the combination side impact air bag system in the Maxima reduced the HIC by up to 66 percent to 5,254, the HIC level was nevertheless high enough to have caused fatal injuries. On the other hand, the results of the test of the Maxima vehicle in a 90-degree FMVSS

No. 201 pole test (Table 6, *infra*) showed successful results with a HIC score of 130.

The 75-degree impact produces a different dummy head trajectory. Judging from the film coverage of the Maxima test, in the oblique pole test, the combination SIAB in the Maxima did not prevent the occupant head from rotating into the pole.<sup>42</sup> In order to comply with the proposed oblique pole test requirements, NHTSA expects that manufacturers will install head protection systems extending sufficiently toward the A-pillar to protect the head in the 75-degree approach angle test. Further, the proposed 32 km/h (20 mph) oblique pole test has a lateral component of 31 km/h (19.3 mph). Thus, it has at least 15 percent<sup>43</sup> more kinetic energy than the

FMVSS No. 201 90-degree pole test at 18 mph.

In the four tests using the FMVSS No. 214 seating position, the ES–2re rib deflection exceeded the maximum deflection in the proposed range (*i.e.*, 44 mm or 1.73 in) in half of the vehicles tested. The ES–2re rib deflection was exceeded in both tests of the 1999 Volvo and 2000 Saab vehicles. All of the vehicles in this series were equipped with thorax air bags of some type. Of the two vehicles that met the rib deflection criteria, the 2004 Toyota Camry test was very close to the proposed upper 44 mm (1.73 in) limit with a rib deflection of 43.4 mm (1.71 in). However, the other vehicle, the 2004 Honda Accord, met the lowest proposed rib deflection criteria with more than 4 mm to spare. Thus, the Accord demonstrates the practicability of meeting the proposed requirements using the FMVSS No. 214 seating procedure.

In the five tests using the FMVSS No. 201 seating position, the ES–2 rib deflection exceeded the proposed upper limit of 44 mm (1.73 in) in one of the two vehicles equipped with air curtains

approximated by the difference between (20 mph)<sup>2</sup> and (18 mph)<sup>2</sup> divided by (18 mph)<sup>2</sup>.

<sup>42</sup> A copy of the film is available from the FHWA/NHTSA National Crash Analysis Center Film Library, 20101 Academic Way, Suite 203, Ashburn, VA 20147–2604. Telephone: 703–726–8236; Fax: 703–726–8358.

<sup>43</sup> The 15 percent increase in kinetic energy was computed by taking the difference in kinetic energy (1/2 mass\*velocity<sup>2</sup>) for both velocities of 18 mph and 19.3 mph for a given vehicle and dividing it by the baseline kinetic energy at 18 mph. Since the mass of the vehicle is constant in this example, the percent increase in kinetic energy was



and no separate chest air bag (Saturn L200). The ES-2 rib deflection was also exceeded in one vehicle equipped with a combination head/chest side air bag (Saab 9-5). The three remaining vehicle tests (Nissan Maxima, Ford Explorer, and Volvo S80) did not result in rib deflection readings above the proposed upper limit. The Ford Explorer did, however, exceed the limits on lower spine acceleration and abdominal force, which might have been partially due to the fact that the vehicle only had an air curtain system and no thorax air bag. (See Table 3.)

D. Comparing the ES-2re to the SID-H3

NHTSA believes that the ES-2re and the SID-H3 would yield similar benefits in head protection. Of the two, NHTSA prefers the ES-2re for its overall superior biofidelity and additional injury assessment capability.

In comparing the biofidelity of the two dummies, the ISO and other researchers (Rhule, *et al.*, 2002) found that the ES-2re dummy demonstrates more human-like response than the

SID-H3 in virtually every category examined.<sup>44</sup>

The agency believes that more effective and encompassing test tools should be used to assess the effectiveness of side impact countermeasures, particularly those involving head air curtains and either seat or door mounted air bags. The ES-2re, with the more human-like rib cage geometry, mass distribution, and telescopic rib compression mechanism, provides the capability of measurement of chest compression. It also has an abdomen that is a weighted deformable element with internal load cells to measure load transfer through to the spine. Given that abdominal injuries constitute up to 20 percent of all injuries in side impact, it is desirable that an ATD can assess this injury. Of lesser significance, but still of importance, is the ES-2re dummy's instrumentation of the pelvis. Besides acceleration, it permits the measurement of force through the iliac wing to the sacrum and pubic symphysis.<sup>45</sup>

However, as noted above, NHTSA is considering using the SID-H3, particularly if all of the injury measures available in ES-2re are not adopted in FMVSS No. 214. The SID-H3 has been used for years in the optional vehicle-to-pole test in FMVSS No. 201 and is acceptably biofidelic as a test device. While SID-H3 is not as advanced an ATD as the ES-2re, it can measure head acceleration and is still an improvement over the SID. HIC would be limited to 1,000 as it is now in FMVSS No. 201. TTI and pelvic acceleration would be limited as they are now specified for the SID in the MDB test. TTI(d) would have an 85g limit for 4-door vehicles and a 90g limit for 2-door vehicles. The pelvic acceleration would be limited to 130g.

NHTSA has conducted three oblique pole tests with the SID-H3 dummy using the FMVSS No. 201 seating procedure. Table 4 shows that all three vehicles tested with the SID-H3 dummy would not comply with one or more of the proposed injury criteria in that test.

TABLE 4.—75—DEGREE OBLIQUE POLE TEST RESULTS  
[SID-H3 Dummy]

Test vehicle	Restraint*	HIC <sub>36</sub>	TTI(d)	Pelvis-g
<b>Using FMVSS No. 214 seating position</b>				
Proposed Limits .....	.....	1,000	**85/90	130
1999 Volvo S80 .....	AC+Th .....	395	49.0	59.1
2000 Saab 9-5 .....	Comb .....	182	77.0	82.1
<b>Using FMVSS No. 201 seating position</b>				
1999 Volvo S80 .....	AC+Th .....	2,213	57.0	55.7
2000 Saab 9-5 .....	Comb .....	5,155	90.5	80.4
2002 Ford Explorer .....	AC .....	330	105.0	81.3

\*Comb.=head/chest SIAB; AC=air curtain; Th=chest SIAB  
\*\*4-door/2-door.

The results of the first oblique pole test using the FMVSS No. 201 seating position exceeded the HIC-1000 criterion, the last test exceeds the TTI(d)-85 criterion, and the second test exceeded both the head and the chest injury criteria. The 1999 Volvo S-80 exceeded the HIC-1000 requirement by 1,213. In this oblique pole test with the SID-H3, using the FMVSS No. 201 seating procedure, the SID-H3's head contacted a joint area of the air curtain and the tether hardware. The air curtain apparently was not large enough to

prevent a partial head-to-pole contact. In contrast, in the 90-degree pole test shown in Table 7, *infra*, of a Volvo S-80, the SID-H3's HIC score was 237. The HIC score of the SID-H3 in the oblique Saab test was 5,155. In the oblique pole test of the Saab, the SID-H3's head partially contacted the front upper edge of the combination head/chest air bag and then rotated into the pole. These HPS designs would likely need to be changed if an oblique pole test were adopted, and the SID-H3 dummy were used, to expand the

contact area covered to prevent the SID-H3 dummy head from rotating into the pole.

It should be noted that when the aforesaid two tests were repeated using the FMVSS No. 214 seating procedure, the HIC scores were dramatically lower. Compared to the FMVSS No. 201 seating position, the FMVSS No. 214 seating position can place the dummy rearward and closer to the B-pillar. Since the production HPS was wide enough to cover the dummy head

<sup>44</sup> "Development of a New Biofidelity Ranking System for Anthropomorphic Test Devices" (Stapp Car Crash Journal, Vol. 46, November 2002, pp. 477-512).

<sup>45</sup> Another advantage of the ES-2re dummy is that it is equipped with an articulating arm that can be placed at the side of the thorax, where it acts as an

interposer between the vehicle interior and the chest. The arm may also be positioned so that it is elevated, simulating the driving position for the driver, leaving the thorax exposed to direct contact by the vehicle door. The test procedures for the proposed oblique pole test specify elevating the arms of the dummy in the driver's seat, simulating

the driving position. In contrast, the SID-H3 dummy's arm is built into the torso jacket and can only simulate the condition where the arm is down. Thus, to the extent that the ES-2re dummy's arm can be positioned in more than one way, that dummy is better able to simulate the results of a variety of side impact crashes.

trajectory in this seating position, the HIC values were significantly lower.

## 2. 5th Percentile Female Dummy (SID-IIsFRG)

NHTSA's analysis of side impact crash data found that nearly 35 percent of all MAIS 3+ injuries in near-side, non-rollover, tow-away side crashes occurred to small stature occupants (between 56–64 inches or 142–163 cm in height). Most of these (93 percent) were female. *Id.* The 1990–2001 NASS/CDS data also indicate that there are differences in the body region distribution of serious injuries between small and medium stature occupants that are seriously injured in these side collisions. The data suggests that small stature occupants have a higher proportion of head, abdominal and pelvic injuries than medium stature occupants, and a lesser proportion of chest injuries.

The SID-IIs 5th percentile female dummy has a mass of 44.5 kg (98 pounds) and a seated height of 790 mm (31.1 inches). The dummy is capable of measuring forces to the head, neck, shoulder, thorax, abdomen and pelvis body regions and measures compression of the thoracic region.<sup>46</sup> NHTSA proposes to use a modified version of the dummy in the oblique pole test to improve the real world protection of small stature occupants in side impacts.

### A. Background

The development of a small, second generation side impact dummy was undertaken in 1993 by the Occupant Safety Research Partnership (OSRP) under the umbrella of the U.S. Council on Automotive Safety Research. There was a need for an ATD that would be better suited to help evaluate the biomechanical performance of advanced side impact countermeasures, notably air bags, for occupants that are smaller than the 50th percentile size male. Data from frontal testing for similar air bag exposures indicated that smaller dummies were generally subjected to higher loadings than the 50th percentile male dummies. The new dummy was named SID-IIs indicating "SID" as side impact dummy, "II" as second generation, and "s" as small. The OSRP completed the development of the SID-IIs as a beta prototype in late 1998.

The dummy was extensively tested in the late 1990s and early 2000 in vehicle crashes by Transport Canada, and to a

limited extent by U.S. automobile manufacturers and suppliers and the IIHS. NHTSA began an extensive laboratory evaluation of the dummy in 2000. Initial testing revealed chest transducer mechanical failures and some ribcage and shoulder structural problems. NHTSA's Vehicle Research and Test Center modified the dummy's thorax in 2001 to incorporate floating rib guides ("FRG") to better stabilize the dummy's ribs. It was visually observed in abdominal-loading sled tests of the SID-IIs that the ribs did not stay in place in some of the tests, which raised concerns regarding the accuracy of the acceleration and deflection measurements, as well as the durability of the ribs and the deflection potentiometers. NHTSA modified the shoulder and rib guide design to remove excessive vertical rib motion. A detailed discussion of these modifications is provided in a technical report entitled, "Development of the SID-IIs FRG," Rhule and Hagedorn, November 2003, that has been placed in the docket for this NPRM.

NHTSA expects to publish a proposal to incorporate the specifications and calibration procedures for the 5th percentile female dummy in Part 572 in 2004. The agency has placed a technical report and other materials describing the dummy, as modified by NHTSA with floating rib guides, in the Docket for today's NPRM. The SID-IIs is well-known to industry and researchers since it has been produced and used for about 5 years and is extensively used by Transport Canada, by IIHS in its consumer ratings program of vehicles' side impact performance with a moving barrier, and by industry to meet industry standards with respect to the safety performance of side air bags and with respect to the risks of side air bags to out-of-position children and small adults.

**Biofidelity.** The Small Sized Advanced Side Impact Dummy Task Group of the OSRP evaluated the SID-IIs Beta-prototype dummy against its previously established biomechanical response corridors for its critical body regions. (Scherer, *et al.*, "SID IIs Beta+-Prototype Dummy Biomechanical Responses," 1998, SAE 983151.) The response corridors were scaled from the 50th percentile adult male corridors defined in an ISO Technical Report 9790 to corridors for a 5th percentile adult female, using established ISO procedures. Tests were performed for the head, neck, shoulder, thorax, abdomen and pelvic regions of the dummy. Testing included drop tests, pendulum impacts and sled tests. The biofidelity of the dummy was calculated

using a weighted biomechanical test response procedure developed by the ISO. The overall biofidelity rating of the SID-IIs beta+-prototype was 7.0, which corresponds to an ISO classification of "good." *Id.*

The agency also used the biofidelity ranking system developed by Rhule, *et al.*, 2002, *supra*, to assess the biofidelity of the SID-IIs with FRG hardware. (See "Biofidelity Assessment of the SID IIsFRG dummy," a copy of which has been placed in the docket.) The assessment included the dummy's External Biofidelity and Internal Biofidelity. The SID-IIsFRG dummy displayed Overall External Biofidelity comparable to that of the ES-2re. The SID-IIsFRG provided improved biofidelity over the SID-H3 in all body regions except for the head/neck. The Overall Internal Biofidelity ranks of the SID-IIsFRG are all better than those of the other dummies, with the exception of the "without abdomen and with TTI" rank. All body region Internal Biofidelity ranks were better than, or comparable to, those of the ES-2re, ES-2 original, and SID-H3, except for the Thorax-TTI, which had a rank of 2.9. However, the SID-IIsFRG dummy is a deflection-based design and is not expected to rank well in this parameter. Even with an Internal Thorax-TTI rank of 2.9 included in the Overall rank (without abdomen), the SID-IIs Internal Biofidelity rank (1.6) is equivalent to that of the ES-2re (1.6) and better than that of the SID-H3 (1.9).

### B. Injury Criteria

Injury criteria are being proposed for the head, lower spine and pelvic regions. A complete discussion of these injury criteria and supporting data can be found in NHTSA's research paper, "Injury Criteria for Side Impact Dummies," and the Preliminary Economic Assessment, which have been placed in the Docket for this NPRM.

**Head:** The head injury criterion (HIC) shall not exceed 1000 in 36 ms, when calculated in accordance with the equation specified in S7 of FMVSS No. 201. This measure has been chosen for the reasons discussed with respect to the ES-2re, *supra*.

**Thorax (Chest):** The agency is not proposing a limit on chest deflection at this time. The agency would like to obtain more data on the dummy's rib deflection measurement capability under oblique loading conditions before proceeding with a proposal limiting such deflections in oblique side impact tests. Further assessment of the injury criteria applied to the SID-IIsFRG is also needed. NHTSA will continue to

<sup>46</sup> IIHS began using the SID-IIs in June 2003 in a side impact consumer information program rating the performance of vehicles in tests with a moving deformable barrier. Measures are recorded from the dummy's head, neck, chest, abdomen, pelvis and leg.

monitor rib deflections in tests using the SID-IIsFRG for further consideration.

NHTSA is proposing that the resultant lower spine acceleration must be no greater than 82 g. The resultant lower spine acceleration is a measure of loading severity to the thorax. In vehicle crashes, loading can be in various directions. Therefore, NHTSA believes that to account for overall loading, resultant accelerations should be considered rather than lateral acceleration alone. Though dummy-measured accelerations for the level of loading severities experienced in vehicle crashes might not have a causal relationship to injury outcome, they are good indicators of thoracic injury in cadaver testing and overall loading to the dummy thorax.

NHTSA selected the criterion based upon the series of 42 side impact sled tests using fully instrumented human cadaveric subjects, previously discussed, conducted at the MCW as well as sled tests conducted with the SID-IIs dummy under identical impact conditions as the cadaveric sled tests. The agency believes that the age of the subject involved in a side impact affects injury outcome. Subject age in the MCW sled test data was found to have significant influence on injury outcome and so was included in the injury models. The resulting thoracic injury risk curves were normalized to the average age of the injured population in a side impact crash that is represented by the SID-IIs dummy. The average age of AIS 3+ injured occupants less than 1,63 cm (5 feet 4 inches) involved in side impact crashes with no rollovers or ejections was 56 years based on NASS-

CDS files for the year 1993–2001. Therefore, thoracic injury risk curves were normalized to the average occupant age of 56 years.

However, the agency’s research has found that the resultant lower spine acceleration might over-predict injury risk at certain levels, or in other words, have a high “false positive” rate. Consequently, the agency selected a conservative resultant lower spine acceleration limit of 82 g to ensure a low false positive rate of approximately 5 percent. This corresponds to an approximate 60 percent risk of AIS 3+ injury. While this risk level is notably higher than that being proposed for the 50th percentile male dummy, the agency also balanced the SID-IIsFRG injury criteria with the practicability of vehicles being able to meet the proposed requirements. For example, if the agency were instead to consider a 50 percent AIS 3+ injury risk (as proposed for the 50th percentile male dummy) the corresponding lower spine acceleration limit would be approximately 62 g. Based on our limited testing to date (see Table 5), we believe this limit would be too low for vehicles to practicably meet. Therefore, we believe our proposal of 82 g strikes a good balance. The agency recognizes that there are construction differences in the spine box between the ES-2re and the SID-IIs. NHTSA plans to continue testing these dummies in vehicles and monitor the differences in lower spine responses, if any.

*Pelvis and Abdomen:* As presented in the report “Injury Criteria for Side Impact Dummies,” the pelvic injury criterion was developed from an analysis of the same cadaver impact

data that was used for the development of the ES-2re pelvic injury criterion. The measured loads in these impact tests were distributed over a broad area of the pelvis that included the iliac crest and the greater trochanter.<sup>47</sup> The measured applied pelvic force to the cadaveric subjects was mass-scaled to represent the applied forces on a 5th percentile female. Under similar impact conditions, the scaled applied pelvic forces on the cadaveric subjects was assumed to be equal to the sum of the iliac and acetabular forces measured on the SID-IIsFRG dummy.<sup>48</sup> Therefore, the pelvic injury risk curves developed for the SID-IIsFRG dummy are based on the maximum of the sum of the measured acetabular and iliac force. The proposed 5,100 N force level for the SID-IIsFRG corresponds to approximately 25 percent risk of AIS 3+ pelvic fracture.<sup>49</sup>

As with the SID-IIsFRG rib deflection instrumentation, the agency would like to obtain more data on the dummy’s abdominal measurement capability under oblique loading conditions before proceeding with a proposal limiting such deflections in oblique side impact tests. Data on abdominal deflection and other measures will continue to be monitored by NHTSA in all future tests using the SID-IIsFRG dummy.

C. Oblique Pole Tests With 5th Percentile Female Dummy

NHTSA has conducted three oblique pole tests with the SID-IIsFRG dummy seated in the full forward position. The test results are presented in the following Table 5:

TABLE 5.—75-DEGREE POLE TEST RESULTS [SID-IIsFRG dummy]

Test vehicle	Restraint*	HIC <sub>36</sub>	Lower spine (g)	Pelvis (N)
Proposed Limits .....	.....	1,000	82	5,100
2003 Toyota Camry (tested April 2003) .....	AC+Th (remotely fired at 11 ms) .....	512	70	4,580
2003 Toyota Camry (tested March 2003) .....	AC+Th (bags did not deploy) .....	8,706	78	5,725
2000 Saab 9–5 .....	Comb. ....	2,233	67	6,045
2002 Ford Explorer .....	AC (remotely fired at 13 ms) .....	4,595	101	7,141

\* Comb.=head/chest SIAB; AC=air curtain; Th=chest SIAB

These data indicate that the most serious problem in terms of protecting small occupants in oblique crashes is lack of head protection. NHTSA believes that this can be resolved by providing an inflatable head protection

system that has been re-designed to address small occupants. The practicability of this approach is illustrated by the results for the 2003 Camry (air curtain and thorax side air bag system) tested in April 2003 (HIC

512). In contrast, in a March 2003 test of the Camry in which the air curtain and thorax bags did not deploy, the SID-IIsFRG had a HIC of 8,706.

The agency’s Preliminary Economic Assessment for this NPRM estimates

<sup>47</sup> The bony protrusion at the top of the femoral shaft opposite the ball of the hip joint.

<sup>48</sup> IIHS used the same assumption when developing performance standards for its consumer ratings program. See Arbalaez, R. A., *et al.*,

“Comparison of the EuroSID-2 and SID-IIs in Vehicle Side Impact Tests with the IIHS Barrier,” 46th Stapp Car Crash Journal (2002).

<sup>49</sup> In the IIHS side impact consumer ratings program, 5,100 N is the injury parameter cutoff

value for the “Good-Acceptable” range for the combined acetabulum and ilium force values. [http://www.highwaysafety.org/vehicle\\_ratings/measures\\_side.pdf](http://www.highwaysafety.org/vehicle_ratings/measures_side.pdf).

that the use of the SID-IIIFRG in the oblique pole test would save an additional 164 lives beyond the fatalities saved by changes to vehicle designs to meet an oblique pole test using the 50th percentile male dummy alone.

*c. FMVSS No. 201 Pole Test Conditions*

The agency is considering the possibility of using a 29 km/h (18 mph) 90 degree impact test, such as that incorporated into FMVSS No. 201's pole test (or a 90 degree test conducted at a 32 km/h (20-mph) test speed). The 90 degree impact angle has proven itself

repeatable and an acceptable way to ensure some level of performance of head protection systems in perpendicular, vehicle-to-narrow-object impacts. An advantage to having the impact angle and test speed be the same as that used in FMVSS No. 201 would be that inflatable head protection systems that are already in place in many vehicles would meet these criteria when tested in a 90-degree impact. Using the same test as is currently optional would possibly allow the installation of inflatable head protection systems in all vehicles faster and at lower cost. A disadvantage is that fewer

lives would be saved. (NHTSA estimates that 446 lives would be saved by the FMVSS No. 201 test using the 50th percentile male dummy, while 792 lives would be saved by the oblique pole test using the 50th percentile male dummy. An estimated 859 lives would be saved by the oblique pole test using both the 5th percentile female dummy and the 50th percentile male dummy.)

NHTSA has conducted several 29 km/h (18 mph) 90-degree pole tests of vehicles equipped with either the combination head/chest SIAB or side window air curtain (AC) systems, using the ES-2 dummy. See Table 6.

TABLE 6.—FMVSS NO. 201 POLE TEST 90-DEGREE TEST RESULTS [ES-2 Dummy]

Test vehicle	Restraint *	HIC <sub>36</sub>	Rib-def. (mm)	Lower spine (gs)	Abd.-force (N)	Public-force (N)
Proposed Limits .....	.....	1,000	35–44	82	2,400–2,800	6,000
1999 Maxima .....	Comb. ....	130	33.0	45.7	1,450	2,080
1999 Cougar .....	Comb. ....	313	41.5	56.6	859	2,214
1999 Volvo S80 .....	AC+Th .....	244	41.5	36.7	1,217	1,166
1999 Ford Windstar .....	Comb. ....	164	31.4	53.5	2,352	1,382
2000 Saab 9–5 .....	Comb. ....	114	37.8	40.2	849	1,733
2001 Saturn L200** .....	AC .....	435	46.0	68	1,084	1,917
2002 Ford Explorer .....	AC .....	208	45.9	65.5	2,074	1,262

\* ITS=inflatable tubular structure; Comb=combination head/thorax air bag; AC=air curtain; Th=chest SIAB.  
 \*\* Lateral back plate lateral load 2,047 N.

Based on the test results using the ES-2 dummy, inflatable head protection systems appear to be working relatively well in protecting the occupant's head in a perpendicular test. All HIC measurements were well below the 1,000 limit. The lower spine g's and other force measurements were below the proposed limits. However, rib deflections exceeded the proposed 44 mm (1.73 in) upper limit in a test of a sport utility vehicle (SUV) (Ford Explorer) and a passenger car (Saturn L200) (both of which had no additional thorax protection, but just an air curtain for the head), and was close to the limit in tests of two other passenger cars. This suggests that if a 90-degree vehicle-to-pole test with an ES-2 dummy were added to FMVSS No. 214, it is likely that the installation of additional chest protection countermeasures would be needed in many production vehicles to comply with a rib deflection criterion in the range of 35–44 mm.<sup>50</sup>

All test results listed in Table 6 were from the ES-2 without the "rib extension" fix, in which back plate lateral loads were considered low (under 1000 N)(224.8 lb). As discussed earlier in this preamble, the agency has

developed a fix (which consists of "rib extensions," a set of two needle bearings for each rib plus a Teflon coated back plate) to minimize or eliminate the grabbing force. The extended ribs provide a continuous loading surface that nearly encircles the thorax and enclose the posterior gap of the ES-2 ribcage. As such, for tests using the ES-2 without the fix in which there were large back plate loads, the rib extensions can result in increased rib deflections in the modified dummy since an intruding structure can no longer grab the dummy back plate without loading the rest of the thorax. As discussed in the agency's technical report for the ES-2re dummy, the results of two 2002 Impala side NCAP tests show that the agency's fix has reduced the grabbing force from 4.7 kN (989 pounds) to practically zero. The tests also show that the rib deflection increased from 16–24 mm (0.63–0.94 inches) to 43–51 mm (1.69–2.01 inches).

NHTSA believes that tests using the ES-2 without the fix in which there were small back plate loads reflect the likely performance of vehicles in tests with the ES-2re. Two sets of side NCAP tests were conducted using a 2003 Toyota Corolla and a 2001 Ford Focus.

The results showed that the rib extension fix did not adversely affect the results when the back plate grabbing force was reported to be low in the original ES-2 design.

With regard to abdominal force in the FMVSS No. 201 pole tests, the abdominal force measurements were far below the 2,800 N (629 pound) proposed upper limit. However, the ES-2 dummy in the Ford Windstar and the Ford Explorer produced a significantly higher abdominal force than in the five passenger cars. These two vehicles, being relatively higher and heavier than passenger cars, can comply with those requirements relatively easily when tested with the MDB. However, as mentioned previously, a higher and heavier vehicle would not have much advantage, if any, over an average passenger car in the proposed pole test.

Since 1999, the agency has conducted eleven 29 km/h (18 mph) 90-degree pole tests using the SID-H3. Ten of these were in the agency's compliance test program of FMVSS No. 201, and one was conducted for research purposes. The results are tabulated below in Table 7:

<sup>50</sup> The test data also show that the vehicles exceeded or came close to exceeding the 42 mm

(1.65 inch) limit specified by the European Union, EU 96/27/EC.

TABLE 7.—FMVSS No. 201 POLE TEST 90-DEGREE TEST RESULTS  
[SID-H3 Dummy]

Test vehicle	Restraint*	HIC <sub>36</sub>	TTI(d)	Pelvis-g
Proposed Limits .....		1,000	85/90(4-door/2-door) .....	130
1999 Volvo S80 .....	AC+Th	237	36.0 .....	44.0
1999 BMW 328i .....	ITS+Th	340	47.0 .....	49.0
2001 Saturn L200 .....	AC	579	63.0 .....	47.7
2001 Lexus GS-300 .....	AC+Th	336	51.3 .....	55.7
2001 VW Jetta .....	AC+Th	444	38.0 .....	40.5
2001 Mercedes C240 .....	AC+Th	457	78.9 .....	60.2
2002 Ford Explorer .....	AC	183	83.0 .....	48.0
2002 Mercedes C230 .....	AC+Th	306	47.0 .....	49.8
2002 Jaguar X-type .....	AC+Th	271	46.6 .....	44.3
2002 Saturn Vue .....	AC	533	53.1 .....	51.5
2003 Cadillac CTS .....	AC+Th	281	45.8 .....	46.6

\*ITS=inflatable tubular structure; AC=air curtain; Th=chest SIAB.

These test results indicate that inflatable head protection systems perform adequately in protecting an occupant's head in a 90-degree impact. The HIC measurements are well below the 1,000 limit. In contrast, the 1999 BMW 328i and the 2001 Saturn L200, when tested without the HPSs (not shown), received HIC scores of 2,495 and 11,071, respectively. The pelvis accelerations in the above tests are also well below the 130 g's allowable limit. Based on the above pole test data, NHTSA believes that the current production vehicles, when equipped with an inflatable head protection system, would comply with the proposed 90-degree pole test requirements if the tests were performed with a SID-H3 dummy (even assuming the FMVSS No. 201 seating position were used).

In general, the TTI(d) measurements are also low. Judging from the above limited test results, NHTSA believes that the safety countermeasures that have been installed in passenger cars to comply with existing FMVSS No. 214 requirements (*i.e.*, the MDB side impact requirements (for the chest and the pelvis)) also provide significant protection in 90 degree, 29 km/h (18 mph) impacts against a rigid narrow object.

However, these tests indicate also that in vehicles with a greater riding height relative to the MDB, the dummy's chest is loaded more severely in a pole test than in the standard's MDB test. Thus, many LTVs would likely have a harder time in a pole test than in an MDB test in meeting the thoracic protection criteria of FMVSS No. 214. For example, the Ford Explorer did not comply with the TTI(d)-85g limit in the oblique pole test (Table 4). The Explorer barely met the TTI(d)-85g limit in a 90-degree test (Table 7). The Ford Explorer had a TTI(d) of 83 g's, approaching the

TTI(d)-85g limit. As noted above, it is easier for an SUV to comply with the MDB test requirements because of the greater ride height and greater mass of the SUV relative to the MDB. (To illustrate, NHTSA tested the 2002 Ford Explorer in the side NCAP configuration with the MDB and the results showed that both the driver and the rear seat passenger received a low TTI(d) score of 35 g's.)

#### VII. Proposed Improvements of Moving Deformable Barrier Test

##### *a. Replacement of Existing 50th Percentile Male Dummy With ES-2re and Addition of Injury Criteria*

This NPRM proposes to require use of an improved 50th percentile male dummy (the ES-2re) in the MDB test in place of the SID and would take advantage of the enhanced injury assessment capabilities of the dummy by specifying injury criteria consistent with those developed for the dummy. These criteria are the same ones proposed above for the vehicle-to-pole test. Comments are requested on using the SID-H3 dummy in the test.

This NPRM would also maintain the current FMVSS No. 214 applicability of the MDB test to LTVs with a GVWR of 2,722 kg (6,000 lb) or less.<sup>51</sup> At this time, we do not believe that applying the MDB test to LTVs with a GVWR over 2,722 kg (6,000 lb) would provide safety benefits to occupants of these heavier vehicles, yet it would add test burdens. However, while LTVs with a GVWR over 6,000 lb would continue to be excluded from the MDB requirements, today's proposed pole test would apply to LTVs with a GVWR of up to 4,536 kg (10,000 lb). The pole test is a more stringent test of the thorax of occupants

<sup>51</sup> LTVs with a GVWR over 6,000 lb were excluded from the MDB requirements because they could meet the MDB requirements prior to the extension of the requirements to LTVs.

of heavier struck LTVs than the MDB test and would result in reduced chest injuries.

With regard to thoracic injury criteria, some vehicles that now meet the MDB test in FMVSS No. 214 when tested with the SID might exceed the proposed rib deflection limit when tested with the ES-2re dummy and so might need to be redesigned. NHTSA's 1999 Report to Congress (Status of NHTSA Plan for Side Impact Regulation Harmonization and Upgrade, March 1999) showed that 3 of 8 FMVSS No. 214 compliant vehicles exceeded the European 42 mm (1.65 inch) rib deflection limit in tests performed according to the EU 96/27/EC side impact test procedures. (The EU 96/27/EC specifies the use of the EuroSID-1 dummy, a different barrier, a different angle of impact and different injury criteria.) Since the proposed ES-2 dummy is more sensitive than the EuroSID-1 dummy to thoracic impact forces, more vehicles would have likely exceeded the rib deflection limit in the aforesaid European side impact tests if the ES-2 dummy had been used. Additionally, the lateral velocity component of the FMVSS No. 214 MDB is roughly equivalent to the 50 km/h (30 mph) impact velocity specified in the EU 96/27/EC, but the U.S. MDB is much heavier and stiffer than the European barrier. Judging from these facts, NHTSA believes that some U.S. vehicles might not comply with the proposed upper limits of 44 mm (1.73 inch) upper limit for rib deflection and/or the 2,800 N (629 pound) upper limit for abdominal force criterion without redesign, if the ES-2re dummy were used in FMVSS No. 214 MDB side impact tests. Based on test results of certain vehicles, the agency has tentatively concluded that it is feasible to meet the proposed requirements.

The agency has conducted FMVSS No. 214 crash tests using the ES-2re and

MDBs of various configurations and weights moving at various impact speeds. These tests are discussed in detail in the ES-2 Technical Report that has been placed in the docket. Two

FMVSS No. 214 MDB tests were conducted using the test procedures specified in the standard and the ES-2re in the driver and rear passenger seating positions. Test results are tabulated

below in Tables 8 and 9 for tests of the dummy in the driver and rear passenger positions, respectively.

TABLE 8.—FMVSS NO. 214 MDB TEST RESULTS  
[ES-2re driver]

Test vehicle	Restraint HPS and/or SIAB	HIC <sub>36</sub>	Rib-def. (mm)	Lower spine (g)	Abd.-force (N)	Pubic-symph. (N)
Proposed Limits .....	.....	1,000	35-44	82	2,400-2,800	6,000
2001 Ford Focus .....	None .....	137	36	60	1,648	2,833
2002 Chevrolet Impala .....	None .....	69	46	49	1,225	1,789

TABLE 9.—FMVSS NO. 214 MDB TEST RESULTS  
[ES-2re rear passenger]

Test vehicle	Restraint HPS and/or SIAB	HIC <sub>36</sub>	Rib-def. (mm)	Lower spine (g)	Abd.-force (N)	Pubic-symph. (N)
Proposed Limits .....	.....	1,000	35-44	82	2,400-2,800	6,000
2001 Ford Focus .....	None .....	174	20	59	1,121	2,759
2002 Chevrolet Impala .....	None .....	187	12	58	4,409	2,784

Tables 8 and 9 show that the 2001 Ford Focus would meet the proposed FMVSS No. 214 MDB test requirements when it is tested with the ES-2re dummy (using the injury criteria associated with that dummy). The Ford Focus is a small car. The task is generally easier for large vehicles with a high ride height. The test results of the Ford Focus indicate that an upgraded MDB test using the ES-2re dummy with its associated injury criteria would be practicable.

The test results also show that the 2002 Chevrolet Impala would not comply with all of the proposed FMVSS No. 214 MDB test requirements. It did not meet the 44 mm (1.73 in) rib deflection criterion for the driver dummy (45.6 mm). Also, the abdominal force of the rear seat dummy exceeds the 2,500 N (562 pounds) limit by a large margin. An examination of the passenger compartment interior reveals that the rear armrest design and its location might be the problem. The armrest is made of foam material and its main portion is approximately 75 mm (3 inch) in width, 75 mm (3 inch) in height, and 250 mm (12 inch) in length. The lower edge of the armrest is approximately 100 mm (4 inches) above the seat surface. During a MDB side impact test, the protruded armrest would contact the abdominal area of a 50th percentile male dummy that is placed in the rear outboard seating position on the struck side. A severe abdominal impact is likely to create an excessively large force resulting in injuries. Since the SID dummy does not measure the abdominal force, this

potential injury risk would not be detected in the existing FMVSS No. 214 MDB test. The use of ES-2re dummy in the MDB test would identify this.

It seems evident that the armrest of the Chevrolet Impala can be modified to mitigate this situation. A common modification is to extend the lower edge of the armrest to completely cover the lower torso of the test dummy. This design has already been used in many vehicles, including the 2001 Ford Focus. It is noted that this particular modification might reduce the rear seat width by a small amount.

*b. Addition of 5th Percentile Female Dummy (SID-IIsFRG) and Injury Criteria*

This NPRM also proposes to upgrade the MDB requirements of FMVSS No. 214 by requiring vehicles to comply when tested with the 5th percentile female dummy (SID-IIsFRG). As noted above in this preamble, NASS data show that nearly 35 percent of MAIS 3 and greater side impact injuries occurred to occupants represented by the SID-IIsFRG dummy (5 foot 4 inches and under). The small stature occupant suffered relatively more head and abdominal injuries and relatively fewer chest injuries. These data indicate a safety need for an injury assessment tool representing small stature occupants to supplement the 50th percentile male dummy specified in the MDB test.<sup>52</sup> The

agency proposes that the criteria proposed for the SID-IIsFRG in the vehicle-to-pole test must also be met in the MDB test with the SID-IIsFRG.

Another proposed change to the MDB test in FMVSS No. 214 concerns the provision in S3(b) that excludes passenger car rear seats that are too small to accommodate the SID. The provision would be amended to specify that the seats would be excluded only if they cannot accommodate the SID-IIsFRG. If the seat cannot accommodate the mid-size male dummy but is able to fit the SID-IIsFRG, the seat would not be excluded from the MDB test. Further, the determination as to whether an ES-2re (or a SID-IIsFRG) can be accommodated in the rear seat would be made when using either the ES-2re or the SID-IIsFRG in the driver's seating position. When the SID-IIsFRG is used in the driver's seating position, the driver's seat would be positioned full forward. Adjustable rear seats would be placed in their most rearward, full down position when seating the male or female dummy.

The technical report for the SID-IIsFRG dummy that accompanies this NPRM discusses the crash tests that the agency has conducted using this dummy. Several aspects of those tests are discussed below.

NHTSA tested the Ford Focus and Chevrolet Impala to FMVSS No. 214's MDB test procedure using the SID-IIsFRG in the driver and rear passenger

a 1,500 kilogram (3,300 pound) MDB with a 90 degree impact.

<sup>52</sup> As noted in an earlier footnote, IIHS is using the SID-IIs in its MDB test. Two SID-IIs test dummies are positioned on the struck side of the test vehicle, one in the driver seat and one in the seat behind the driver. The tests are conducted with

seating positions. Test results are tabulated below in Tables 10 and 11.

TABLE 10.—FMVSS No. 214 MDB TEST RESULTS  
[SID—IIIFRG driver]

Test vehicle	Restraint HPS and/or SIAB	HIC <sub>36</sub>	Lower spine (sg)	Pelvis (N)
Proposed Limits .....	.....	1,000	82	5,100
2001 Ford Focus .....	None .....	181	72	5,621
2002 Chevrolet Impala .....	None .....	76	52	2,753
2001 Buick Le Sabre .....	Thorax .....	130	67	4,672

TABLE 11.—FMVSS No. 214 MDB TEST RESULTS  
[SID—IIIFRG rear passenger]

Test vehicle	Restraint HPS and/or SIAB	HIC <sub>36</sub>	Lower Spine (sg)	Pelvis (N)
Proposed Limits .....	.....	1,000	82	5,100
2001 Ford Focus .....	None .....	526	65	3,997
2002 Chev Impala .....	None .....	153	89	5,711
2001 Buick Le Sabre .....	None .....	221	77	14,041

<sup>1</sup> Preliminary.

Tables 10 and 11 show that the 2001 Ford Focus would almost fully comply with the proposed FMVSS No. 214 MDB test requirements when tested with the SID—IIIFRG dummy and its associated injury criteria. Only the pelvis force for the driver dummy was exceeded in this test, which, judging from the film coverage, could be attributed to the intruding armrest.<sup>53</sup> Alternatively, the 2002 Chevrolet Impala was able to meet all of the driver injury criteria with at least a 37 percent margin. The 2001 Buick Le Sabre also met all the proposed criteria for the driver dummy.

The 2002 Chevrolet Impala was the only vehicle that would not comply with the proposed rear seat FMVSS No. 214 MDB test requirements, since both the lower spine acceleration and the pelvis force of the rear seat dummy exceeded the proposed injury limits. As discussed previously, the rear armrest design might be the problem, and a simple remedy appears to be technically feasible.

## VIII. Other Issues

### a. Struck Door Must Not Separate From Vehicle

FMVSS No. 214 currently prohibits any side door that is struck by the moving deformable barrier from separating totally from the vehicle (currently in S5.3.1 of the standard). The standard also requires any door (including a rear hatchback or tailgate)

that is not struck by the moving deformable barrier to meet the following requirements: (a) The door shall not disengage from the latched position; (b) the latch shall not separate from the striker, and the hinge components shall not separate from each other or from their attachment to the vehicle; and (c) neither the latch nor the hinge systems of the door shall pull out of their anchorages. This NPRM proposes to have the same door opening prohibitions apply to vehicles tested in the vehicle-to-pole tests.

### b. Rear Seat

According to 1999 and 2000 Fatality Analysis Reporting System (FARS) data, the front outboard seating positions account for 89.2 percent of total fatalities and 88.8 percent of total injured occupants in passenger cars, and 86.6 percent and 87.6 percent of total fatalities and total injured occupants in LTVs. While these are for all crash conditions, the percentages for side impacts to narrow objects are similar. In nearside crashes, rear occupants make up 7.3 percent, 10.2 percent and 4.4 percent of seriously injured persons in crashes with passenger cars, LTVs and narrow objects, respectively. According to 1997–2001 NASS CDS annualized fatality distribution for rear outboard occupants, there were 22 fatalities caused by a vehicle-to-pole side crash, 7 of which were due to head injury.

The test procedure for the vehicle-to-pole test would call for a test dummy in the front outboard seating position nearest to the side impacting the pole, as in FMVSS No. 201. FMVSS No. 201

does not use a test dummy in the rear seat. Comments are requested on applying the pole test to the rear seat.

We have tentatively decided not to apply the test to the rear seat. This NPRM focuses on the front seat because years of conducting the optional pole test in FMVSS No. 201 have yielded substantial information about meeting pole test requirements in that seat. Less information is known about the rear seat. We have also sought to contain the costs of this rulemaking. Applying the test to rear seats would require at least twice as many tests per vehicle.

Furthermore, NHTSA believes that the countermeasure likely to be widely used to meet the requirements of the proposed vehicle-to-pole test will be air curtains, some of which currently cover both front and rear side window openings and thus provide protection to rear seat occupants. NHTSA tentatively concludes that those air curtains will be large enough to cover both front and rear side window openings. Comments are requested on manufacturers' plans to tether air curtains to the A- and C-pillars of vehicles.

### c. Interaction With Other Side Impact Programs

#### 1. Out-of-Position Criteria

*Background.* The agency has been concerned about the potential risks of side impact air bags (SIAB) to out-of-position (OOP) occupants, particularly children, from the first appearance of side air bag systems in vehicles. NHTSA initiated research in the fall of 1998 into the interactions between OOP children and side air bags. In April 1999, NHTSA

<sup>53</sup> A copy of the film is available from the FHWA/NHTSA National Crash Analysis Center Film Library, 20101 Academic Way, Suite 203, Ashburn, VA 20147–2604. Telephone: 703–726–8236; Fax: 703–726–8358.

held a public meeting to discuss the potential benefits and risks of side impact air bags and the development of possible test procedures to assess those risks.<sup>54</sup>

**Safety Need.** The agency has investigated more than 92 side impact air bag deployment crashes through NHTSA's Special Crash Investigations unit in order to determine whether a problem exists related to OOP occupants. There have been no fatalities and only one confirmed AIS 3+ injury due to a side air bag, this to a 76-year-old male driver. Side air bags<sup>55</sup> do not appear to pose a safety risk to OOP children, even taking into account exposure risks.

**Technical Working Group Recommended Procedures.** In July 1999, the Alliance, AIAM, the Automotive Occupant Restraints Council, and IIHS formed a technical working group (TWG) to develop recommended test procedures and performance requirements to evaluate the risk of side air bags to children who are out-of-position. In August 2000, the TWG issued a draft report, "Recommended Procedures For Evaluating Occupant Injury Risk From Deploying Side Air Bags," The Side Air Bag Out-Of-Position Injury Technical Working Group, Adrian K. Lund (IIHS) Chairman, August 8, 2000. This report was revised in July 2003. The proposed procedures were based on the work of Working Group 3 of the International Organization of Standard (ISO) Technical Committee 10, which had developed draft procedures for evaluating side impact air bags. "Road Vehicles-Test Procedures for Evaluating Occupant Interactions with Deploying Side Impact Airbags." The ISO procedures were finalized in October 2001 (ISO-TR 14933, October 2001).

Under the TWG procedures, a 5th percentile female side impact dummy (SID-II), a 3-year-old and a 6-year-old Hybrid III frontal child dummy are placed in several positions close to the air bag systems. The TWG procedures address side air bags that deploy from the seat backs (seat-mounted), those that deploy from the door or rear quarter panel, typically just below the window sill (side-mounted), those that deploy from the roof rail above the door (roof-mounted), and roof-rail and seat back/

door systems. After the dummy is positioned as specified in the procedures, the air bag is deployed statically, and the dummy injury measures due to the deployment of the air bag are determined. The measured forces are compared to TWG's "Injury Reference Values" and "Injury Research Values."<sup>56</sup> The TWG's limits on the Injury Reference Values are mostly the same as those in FMVSS No. 208 for OOP testing of frontal air bags.

NHTSA initiated a research program to evaluate the TWG procedures and propose, if necessary, any alternatives and modifications to assess the injury risk to OOP children. The agency's test program included 11 vehicles equipped with front seat side air bags and one vehicle equipped with rear seat side air bags. The TWG OOP test procedures were used as the baseline for selecting test positions. However, tests were performed with the basic TWG procedures with and without NHTSA variations. Many different types of production systems, including door-mounted thorax bags, seat-mounted head-thorax combination bags, and roof mounted head protection systems, were tested using 3-year-old and 6-year-old Hybrid-III child dummies. The results were reported in a technical paper, "Evaluation of Injury Risk from Side Impact Air Bags." (Proceedings of the 17th ESV Conference, June 2001, Paper # 331.) The main purpose of the test program was to assess the potential safety risks that any system could pose to OOP small adults and children due to deploying side air bags.

The main observations from the agency's research is summarized in the following:

- The TWG procedures address dummy sizes, seating positions, and expand the traditional injury assessment measures.
- The TWG procedures are quite comprehensive and are very successful at discriminating aggressive SIABs.
- The TWG procedures are adequate baseline procedures for SIAB OOP testing to minimize unreasonable risks to children and small adults.
- For the 3- and 6-year old occupants, the TWG test procedures do not always find the worst case conditions for some current SIAB systems.

**Future Action.** Door- and seat-mounted side impact head and/or chest protection systems in future vehicles might need to be more aggressive

compared to current systems. Comments are requested on how meeting the requirements proposed by this NPRM would affect manufacturers' ability to meet the TWG procedures. The agency is conducting additional tests of the newer side air bag systems that are able to comply with the pole test requirements to assess their risks, if any. The agency will continue to monitor compliance with the TWG test procedures and requirements by automotive manufacturers. In addition, the agency will conduct further testing of new air bag designs. The knowledge gained from the test program will allow us to take any appropriate action in this area if there are indications it is warranted.

## 2. FMVSS No. 201 Pole Test

Currently, FMVSS No. 201 specifies an optional 90-degree, 29 km/h (18 mph) pole test using a SID-H3 driver dummy (1000 HIC test criterion). As noted above, this test was part of a set of amendments adopted to accommodate the installation of head protection systems (HPS) in the pillar and side rail areas. If a vehicle complies with the pole test requirements, the 24.0 km/h (15 mph) head form test is reduced to 19.3 km/h (12 mph) for targets near the stowed HPS.

This NPRM proposes to amend FMVSS No. 201 such that, if the proposed oblique 32 km/h (20 mph) pole test were added to FMVSS No. 214, vehicles certified to that test would be excluded from the 90-degree, 29 km/h (18 mph) pole test in FMVSS No. 201. The agency tentatively concludes that a vehicle that meets the oblique 32 km/h (20 mph) pole test would also meet FMVSS No. 201's 90-degree 29 km/h (18 mph) test. Seat-mounted SIABs that deploy into an area far enough forward to cushion an occupant's head in an oblique impact are also likely to protect the head in a perpendicular one. Similarly, an air curtain tethered to the A- and C-pillars would also provide coverage in both an oblique and perpendicular crash. Since the FMVSS No. 214 pole test would encompass and go beyond the pole crash replicated by the FMVSS No. 201 pole test, there does not seem to be a need for the latter test. Thus, the agency proposes to eliminate the FMVSS No. 201 optional pole test for vehicles certified to the FMVSS No. 214 oblique pole test, to delete an unnecessary test burden on manufacturers. Note, however, that targets near the stowed HPS would still be subject to the head form test of FMVSS No. 201, conducted at the 19.3 km/h (12 mph) test speed specified in that standard.

<sup>54</sup> The agency has placed materials in Docket NHTSA-1999-5098 relating to the risks to out-of-position occupants from SIAB.

<sup>55</sup> For the purposes of this discussion, "side air bags" means side thorax air bags and combination thorax/head air bags, and not side head air bags. Our testing found no reason for concern with side head air bags (window curtains or inflatable tubular structures) and out-of-position children or adults.

<sup>56</sup> Injury Reference Values are those that the majority of the TWG believed have a strong scientific basis. Injury Research Values are those that TWG believes currently have less scientific support or insufficient test experience to allow full confidence in their accuracy.



#### d. Harmonization

Today's proposal is consistent with NHTSA's international harmonization policy goal of harmonizing with non-U.S. safety requirements except to the extent needed to address safety problems here in the U.S.

*Dynamic Test For Head Protection.* Worldwide, there are numerous countries that have side impact protection requirements or governmental or non-governmental side impact consumer information programs. Similar to NHTSA's NCAP program, the European NCAP (Euro NCAP) program seeks to provide consumers with reliable and accurate comparative information for use in making purchasing decisions. Euro NCAP incorporates a side impact program, which involves a 50 kph (30 mph) barrier impact into the driver's side of a car, and an optional 29 km/h (18 mph) 90 degree pole test. (EuroNCAP Side impact testing Protocol, Version 4, January 2003.) While these side impact programs are similar to those of the U.S., the safety need addressed by those programs is different from the side impact safety need in the U.S. There are more LTVs in the U.S. fleet than elsewhere. Vehicle compatibility is a relatively unique U.S. problem.

The European Community's side impact safety regulation, EU Directive 96/27/EC, is similar to existing FMVSS No. 214 in specifying a side impact of a moving deformable barrier into the stationary target vehicle. Similar to the MDB test of FMVSS No. 214, a 50th percentile male dummy is placed in the front seat of the target vehicle. (FMVSS No. 214 also specifies placement of another 50th percentile dummy in the vehicle's rear seat.<sup>57</sup>)

The agency has tentatively concluded that adopting our proposed vehicle-to-pole test into FMVSS No. 214 would result in significantly greater benefits than those that would accrue from adopting EU 96/27/EC or the Euro NCAP side impact test into the

<sup>57</sup> The test differs from FMVSS No. 214 in other ways. The MDB has a mass of 950 kg (2,095 lb) compared to 1,367 kg (3,015 lb) for the U.S. barrier. The European barrier's face is smaller and much softer than the U.S. barrier on the blocks closest to the sides. The bottom edge is the most forward part of the European MDB and is 300 mm (11.8 in) from the ground. The U.S. barrier face's bottom edge is 280 mm (11.0 in) from the ground and has a 330 mm (13 in) bumper height. In EU 96/27/EC, the barrier impacts the target vehicle at 50 km/h (30 mph) and 90 degrees with no crab angle. (In FMVSS No. 214, the struck vehicle's wheels are crabbed to simulate movement of the target vehicle.) The injury criteria associated with the EuroSID-1 differ from that of SID. EU 96/27/EC limits HIC, rib deflection (42 mm), Viscous Criterion (1.0), abdominal force (2.5 kN) and the pubic symphysis force (6 kN).

standard.<sup>58</sup> The side impact tests of EU 96/27/EC and Euro NCAP moving barrier test address mainly the chest injury problem. The barrier used in those tests is not representative of the vehicles in the U.S. fleet, which has more SUVs and other LTVs as compared to the European fleet. Further, these tests do not simulate an impact with an exterior narrow rigid structure—which constitutes a serious safety problem today—nor do they address head protection in the manner addressed by our proposed pole test.

Although the Euro NCAP optional pole test is closer to today's NPRM in addressing head protection, the Euro NCAP test is basically the same as the optional FMVSS No. 201 test. NHTSA believes that the oblique pole test proposed today would provide significantly more benefits than those from either of these 90-degree 29 km/h (18 mph) tests.

Work is continuing internationally on a side impact pole test. The International Harmonized Research Activities (IHRA)<sup>59</sup> Side Impact Working Group (SIWG) is actively researching the side impact problem and has proposed that several test procedures for protecting the struck side occupant in side impact crashes be subjected to validation testing. The IHRA SIWG has agreed to adopt NHTSA's oblique impact pole test, pending the results of those validation tests. It has also agreed that head form impact tests similar to that of FMVSS No. 201 is necessary for protecting the occupants on the struck side as the tests pertain to the targets that are likely to be contacted by an occupant's head in a side impact crash.<sup>60</sup>

*Test Dummies and Injury Criteria.* Incorporation of the ES-2 dummy into FMVSS No. 214 in both the vehicle-to-

<sup>58</sup> The side impact protection requirements promulgated by Japan (Article 18, Attachment 23, "Technical Standard for the Protection of the Occupants in the Event of a Lateral Collision") and Australia (Australian Design Rule 72/00, "Dynamic Side Impact Occupant Protection") are those in ECE Regulation 95 EU/96/27/EC. A U.S. final rule adopting the vehicle-to-pole test proposed today would provide greater benefits than those requirements.

<sup>59</sup> IHRA is an inter-governmental initiative that aims to facilitate greater harmony of vehicle safety policies through multi-national collaboration in research.

<sup>60</sup> In addition, they are validating two different moving deformable barrier tests to accommodate the issues of fleet differences between countries. One is the IIHS test, the other is a test performed at the same mass and speed, but uses an advanced barrier face that better reflects the shape and stiffness of a passenger vehicle. The IHRA SIWG also has work underway to validate the test procedures developed by the Side Impact Airbag Out-of-Position Technical Working Group (TWG) for static side impact airbag tests.

pole and MDB tests would be a step toward harmonizing the standard with non-U.S. regulations. The ES-2 dummy is used in the non-governmental Euro NCAP side impact program. While the ES-2 dummy has not yet replaced the EuroSID-1 dummy in the side impact directive of the European Union (EU 96/27/EC), there is work underway in WP.29 to replace EuroSID-1 in ECE Regulation 95 with the ES-2, and in the European Union to subsequently amend the EU Directive accordingly. As noted earlier in this preamble, the GRSP Working Party to WP.29 transmitted a recommended amendment to ECE Regulation 95 to WP.29 for consideration by AC.1 at its November 2003 meeting. The GRSP specifically urged consideration of NHTSA's actions to fix the back plate of the ES-2 by way of the rib extensions.

The injury criteria proposed in this notice for the ES-2re dummy are consistent with the injury criteria now in EU 96/27/EC. The proposed 42 mm (1.65 in) requirement for maximum chest deflection for the ES-2re, the 2,500 N (562 lb) abdominal load injury criterion and the 6,000 N (1,349 lb) pubic symphysis load injury criterion are the same as those applied in the European side impact regulation EU 96/27/EC.

At this time, the SID-II is not used by other countries for regulatory purposes, but Canada uses the dummy for side impact research. Canada does not use the FRG version of the dummy.

#### IX. Estimated Benefits and Costs of Proposed Pole Test

We are placing in the docket a Preliminary Economic Assessment (PEA) to accompany this NPRM.<sup>61</sup> The PEA analyzes the potential impacts of the proposed vehicle-to-pole side impact test and the modifications to the MDB test. A summary of the PEA follows. Comments are requested on the analyses.

*Benefits.* The agency first identified the baseline target population and then estimated the fatality or injury reduction rate. The target population was defined as occupants who sustained fatal and/or AIS 3+ injuries to the head, chest, abdomen or pelvis in side crashes. The target population was initially estimated to be 2,910 fatalities and 7,248 AIS 3-5 injuries in crashes with a delta-V of 19 to 40 km/h (12-25 mph). When adjusted

<sup>61</sup> The PEA may be obtained by contacting Docket Management at the address or telephone number provided at the beginning of this document. You may also read the document via the Internet, by following the instructions in the section below entitled, "Viewing Docket Submissions." The PEA will be listed in the docket summary.

using the 2003 seat belt use rate, the target population estimate was 2,874 fatalities and 7,243 MAIS 3–5 injuries. Target fatalities and MAIS 3–5 injuries were derived from 1997–2001 CDS. In identifying the target population, occupants with heights of 165 cm (65 inches) or taller were assumed to be represented by the 50th percentile male dummy (the SID–H3 or the ES–2re), and the remaining occupants were assumed to be represented by the 5th percentile female dummy (the SID–IIIFRG).

The agency estimated the lives and serious injuries prevented by wider thorax and head window curtain air bags in pole/tree impacts, vehicle-to-vehicle/other road side object crashes (including partial ejections), and non-rollover complete ejections. The analysis assumed that benefits would only accrue in crashes with delta-V in the 19 to 40 km/h (12 to 25 mph) range. Taking into account the presence of head and thorax side air bags already in the MY 2003 new vehicle fleet, the incremental benefits would be 686 fatalities saved and 880 AIS 3–5 injuries prevented if a combination air bag, 2-sensor (per vehicle) system were used. (The combination air bag, 2-sensor system would be the least expensive side air bag system that would enable a vehicle to meet the standard.) If a window curtain and thorax air bag 2-sensor system were used, the benefits would be 1,027 fatalities saved and 999 MAIS 3–5 injuries prevented. If a window curtain and thorax air bag 4-sensor system were used, the benefits are estimated to be 1,032 fatalities saved and 1,037 MAIS 3–5 injuries prevented.

The agency's estimates are based on the distribution of the different types of side air bag systems in the MY 2003 new vehicle fleet, *i.e.*, the percentage of side air bags providing head protection only, those providing thorax protection only, and those providing both head and thorax protection. The distribution of these systems within the new vehicle fleet has changed over the years, *e.g.*, head-only and head/thorax bags increased from MY 2002 to MY 2003, while thorax-only side air bags decreased during that period (see Table V–103 of the PEA for a distribution of side air bag systems in MY 1999–2003 vehicles). Yet, overall, the MY 2003 new vehicle fleet had a lower percent of side air bags than the MY 2002 fleet. Comments are requested on the agency's use of MY 2003 side air bag installation rates as a baseline, the trend in side air bag installation rates, and the ability of the different air bag systems to meet our oblique pole test.

**Costs.** In the PEA, the agency discusses the costs of the different

technologies that could be used to comply with the tests and also estimates compliance tests costs. The agency tentatively concludes that the majority of vehicle manufacturers currently installing side head air bag systems might need to make their present air bags wider. They might not need to add side impact sensors to their vehicles or develop more advanced sensors to meet an oblique pole test. As noted above, NHTSA estimates that the combination air bag, 2-sensor system would be the least expensive side air bag system that would enable a vehicle to meet the standard. The cost for two wider combination head/thorax side air bags with two sensors is estimated to be \$121 per vehicle. Accounting for the degree to which the MY 2003 fleet already has combination side air bags, the average vehicle incremental cost to meet the proposed requirements is estimated to be \$91 per vehicle. If a window curtain, thorax side air bag system were installed with 4 sensors, the average incremental cost per vehicle would be \$264. Given the number of vehicles in the MY 2003 fleet that now have wide window curtains and wide thorax side air bags with four sensors, the average vehicle incremental cost to meet this proposal is estimated to be \$208 per vehicle (2002 dollars). This amounts to a range of \$1.6 to \$3.6 billion for the total incremental annual cost of this proposed rule.

**Net Cost Per Fatality Prevented.** NHTSA estimated the net costs per equivalent life saved, using a 3 and a 7 percent discount rate. Assuming manufacturers were to install a combination head/thorax 2-sensor side air bag system, at a 3 percent discount rate, the cost per equivalent life saved would be \$1.8 million. Assuming manufacturers were to install separate window curtains and thorax air bags with four sensors, the high end of the range is estimated to be \$3.7 million per equivalent life saved, using a 7 percent discount rate.

**Net Benefits.** Net benefit analysis differs from cost effectiveness analysis in that a net benefits analysis involves assigning a monetary value to the estimated benefits. A comparison is then made of the monetary value of benefits to the monetary value of costs, to derive a net benefit. NHTSA estimates that the high end of the net benefits is \$1,447 million for the combination head/thorax air bags using a 3 percent discount rate. The low end is negative \$202 million for the curtain plus thorax bags with four sensors, using a 7 percent discount rate. Both of these are based on a \$3.5 million cost per life.

## X. Proposed Leadtime and Phase-In

**Oblique Pole Test.** Motor vehicle manufacturers will need lead time to develop and install side impact air bags that enable their vehicles to meet the performance requirements proposed today for the oblique pole test. (Substantially less time would be required if the agency chose to utilize a 90-degree pole test and/or the SID–H3 in lieu of the ES–2re dummy.) NHTSA believes that vehicle manufacturers are at different stages with respect to designing side impact air bags, and also face different constraints and challenges, *e.g.*, differences in the technological advances incorporated in their current air bag systems, in engineering resources, in the number of vehicles for which air bags need to be redesigned, etc. NHTSA believes that these differing situations can best be accommodated by phasing-in the upgraded side impact protection requirements proposed today for head protection.

Taking into account all available information, including but not limited to the performance of current vehicles when tested obliquely at the proposed 32 km/h (20 mph) pole test speed and with the advanced dummies proposed today, the technologies that can possibly be used to meet the proposed testing requirements (*e.g.*, head curtains, widened head/thorax bags), and the relatively low percentage of the fleet that has the side air bags capable of meeting the proposed requirements, the agency is proposing to phase in the new vehicle-to-pole test requirements four years from the date of publication of a final rule. The phase-in would be implemented in accordance with the following schedule:

- 20 percent of each manufacturer's light vehicles manufactured during the production year beginning (four years after publication of a final rule; for illustration purposes, September 1, 2009);
- 50 percent of each manufacturer's light vehicles manufactured during the production year beginning September 1, 2010;
- All vehicles manufactured on or after September 1, 2011.

NHTSA believes that the proposed phase-in allows manufacturers to focus their resources in an efficient manner. The agency believes that it would not be possible for manufacturers that produce large numbers of models of passenger cars and LTVs to simultaneously design and install side air bags in all of their vehicles at once. Manufacturers have limited engineering resources, and the same resources are often used for

different models. Manufacturers have also been using their resources to take voluntary actions to improve the compatibility of LTVs and passenger cars in vehicle-to-vehicle crashes. NHTSA wants to give the vehicle manufacturers sufficient opportunity to adopt the best designs possible. At the same time, however, the agency wishes to see head protection air bags implemented expeditiously. The agency believes that a 3-year phase-in is sufficient. NHTSA estimates that about 22 percent of the 2002 model year vehicles sold in the U.S. already have some type of head side air bag system (by way of comparison, only 0.04 percent of the vehicles sold in 1998 had such systems). The agency believes the proposed phase-in balances the above competing concerns.

We are also proposing to include provisions under which manufacturers can earn credits towards meeting the applicable phase-in percentages if they meet the new requirements ahead of schedule.

As we have done with other standards, we are proposing a separate alternative to address the special problems faced by limited line and multistage manufacturers and alterers in complying with phase-ins. A phase-in generally permits vehicle manufacturers flexibility with respect to which vehicles they choose to initially redesign to comply with new requirements. However, if a manufacturer produces a very limited number of lines, a phase-in would not provide such flexibility. NHTSA is accordingly proposing to permit "limited line" manufacturers that produce three or fewer carlines the option of achieving full compliance when the phase-in is completed (in the illustration, September 1, 2011). (The definition of a limited line manufacturer was expanded to manufacturers of three or fewer carlines in a final rule published May 5, 2003 (68 FR 23614), as corrected September 25, 2003 (68 FR 55319).) The same flexibility would be allowed for vehicles manufactured in two or more stages and altered vehicles from the phase-in requirements. All these manufacturers (limited line, multistage and alterers) would, of course, be subject to FMVSS No. 214's existing requirements before and throughout the phase-in.

Also as with previous phase-ins, NHTSA is proposing reporting requirements to accompany the phase-in. The agency is proposing to include the reporting requirements in a new Part 598 in Title 49 of the CFR. (NHTSA has proposed to consolidate into Part 585 the phase-in reporting requirements for

all the FMVSSs with phase-in schedules (68 FR 46546; 46551; August 6, 2003). If that consolidation is made final, a final rule adopting the FMVSS No. 214 reporting requirements would set forth the reporting requirements in Part 585.)

*Upgraded MDB Test.* The upgraded MDB test would be effective 4 years after publication of a final rule. The requirements would not be phased in because NHTSA believes that manufacturers can meet them without the need for a phase in. Countermeasures that include padding and simple redesign of the armrest area are available to some vehicles. Comments are requested on whether it would be appropriate to establish a phase-in for this requirement. Comments are also requested on whether a leadtime shorter than 4 years would be appropriate.

## XI. Rulemaking Analyses and Notices

### *a. Executive Order 12866 (Regulatory Planning and Review) and DOT Regulatory Policies and Procedures*

The agency has considered the impact of this rulemaking action under Executive Order 12866 and the Department of Transportation's regulatory policies and procedures. This rulemaking is economically significant and was reviewed by the Office of Management and Budget under E.O. 12866, "Regulatory Planning and Review." The rulemaking action has also been determined to be significant under the Department's regulatory policies and procedures. NHTSA has placed in the docket a Preliminary Economic Assessment (PEA) describing the costs and benefits of this rulemaking action. The costs and benefits are summarized in section IX of this preamble.

### *b. Regulatory Flexibility Act*

The Regulatory Flexibility Act of 1980, as amended, requires agencies to evaluate the potential effects of their proposed and final rules on small businesses, small organizations and small governmental jurisdictions. I hereby certify that this NPRM would not have a significant economic impact on a substantial number of small entities. Small organizations and small governmental units would not be significantly affected since the potential cost impacts associated with this proposed action should only slightly affect the price of new motor vehicles.

The proposed rule would directly affect motor vehicle manufacturers and indirectly affect air bag manufacturers, dummy manufacturers and seating manufacturers.

This action would not have a significant economic impact on a substantial number of small vehicle manufacturers because the vast majority of companies that manufacture motor vehicles in a single stage are not small businesses.

The agency does not believe that there are any small air bag manufacturers.

There are several manufacturers of dummies and/or dummy parts. All of them are considered small businesses. The proposed rule is expected to have a positive impact on these types of small businesses by increasing demand for dummies.

NHTSA knows of approximately 21 suppliers of seating systems, about half of which are small businesses. If seat-mounted head/thorax air bags are used to meet the new pole test and upgraded MDB test, the proposed requirements would have a positive impact on these suppliers since the cost of the seats would increase. NHTSA believes that air bag manufacturers would provide the seat suppliers with the engineering expertise necessary to meet the new requirements.

NHTSA notes that final-stage vehicle manufacturers and alterers buy incomplete vehicles, add seating systems to vehicles without seats, and/or make other modifications to the vehicle, such as replacing existing seats with new ones or raising the roofs of vehicles. A second-stage manufacturer or alterer modifying a vehicle with a seat-mounted thorax air bag might need to use the existing seat or rely on a seat manufacturer to provide the necessary technology. In either case, the impacts of this NPRM on such entities would not be significant. Final-stage manufacturers or alterers engaged in raising the roofs of vehicles would not be affected by this NPRM. This is because this document proposes to exclude vehicles with raised or altered roofs from the pole test.

Additional information concerning the potential impacts of the proposed requirements on small entities is presented in the PEA.

### *c. Executive Order 13132 (Federalism)*

Executive Order 13132 requires NHTSA to develop an accountable process to ensure "meaningful and timely input by State and local officials in the development of regulatory policies that have federalism implications." "Policies that have federalism implications" is defined in the Executive Order to include regulations that have "substantial direct effects on the States, on the relationship between the national government and the States, or on the distribution of

power and responsibilities among the various levels of government.” Under Executive Order 13132, the agency may not issue a regulation with Federalism implications, that imposes substantial direct compliance costs, and that is not required by statute, unless the Federal government provides the funds necessary to pay the direct compliance costs incurred by State and local governments, the agency consults with State and local governments, or the agency consults with State and local officials early in the process of developing the proposed regulation. NHTSA also may not issue a regulation with Federalism implications and that preempts State law unless the agency consults with State and local officials early in the process of developing the proposed regulation.

We have analyzed this proposed rule in accordance with the principles and criteria set forth in Executive Order 13132 and have determined that this proposal does not have sufficient Federal implications to warrant consultation with State and local officials or the preparation of a Federalism summary impact statement. The proposal would not have any substantial impact on the States, or on the current Federal-State relationship, or on the current distribution of power and responsibilities among the various local officials.

#### *d. Unfunded Mandates Reform Act*

The Unfunded Mandates Reform Act of 1995 (UMRA) requires Federal agencies to prepare a written assessment of the costs, benefits and other effects of proposed or final rules that include a Federal mandate likely to result in the expenditure by State, local or tribal governments, in the aggregate, or by the private sector, of more than \$100 million in any one year (\$100 million adjusted annually for inflation, with base year of 1995). These effects are discussed earlier in this preamble and in the PEA. UMRA also requires an agency issuing a final rule subject to the Act to select the “least costly, most cost-effective or least burdensome alternative that achieves the objectives of the rule.” The preamble and the PEA identify and consider a number of alternatives to the proposal. However, none of these alternatives would fully achieve the objectives of the alternative preferred by NHTSA (20 mph oblique pole test with the ES-2re and the SID-IIs). The agency believes that it has selected the least costly, most cost-effective and least burdensome alternative that achieves the objectives of the rulemaking. The agency requests comments that will aid

the agency in ensuring that this is the case.

#### *e. National Environmental Policy Act*

NHTSA has analyzed this proposal for the purposes of the National Environmental Policy Act. The agency has determined that implementation of this action would not have any significant impact on the quality of the human environment.

#### *f. Executive Order 12778 (Civil Justice Reform)*

This proposal would not have any retroactive effect. Under 49 U.S.C. 21403, whenever a Federal motor vehicle safety standard is in effect, a State may not adopt or maintain a safety standard applicable to the same aspect of performance which is not identical to the Federal standard, except to the extent that the state requirement imposes a higher level of performance and applies only to vehicles procured for the State’s use. 49 U.S.C. 21461 sets forth a procedure for judicial review of final rules establishing, amending or revoking Federal motor vehicle safety standards. That section does not require submission of a petition for reconsideration or other administrative proceedings before parties may file suit in court.

#### *g. Plain Language*

Executive Order 12866 requires each agency to write all rules in plain language. Application of the principles of plain language includes consideration of the following questions:

- Have we organized the material to suit the public’s needs?
- Are the requirements in the rule clearly stated?
- Does the rule contain technical language or jargon that isn’t clear?
- Would a different format (grouping and order of sections, use of headings, paragraphing) make the rule easier to understand?
- Would more (but shorter) sections be better?
- Could we improve clarity by adding tables, lists, or diagrams?
- What else could we do to make the rule easier to understand?

If you have any responses to these questions, please include them in your comments on this proposal.

#### *h. Paperwork Reduction Act (PRA)*

Under the PRA of 1995, a person is not required to respond to a collection of information by a Federal agency unless the collection displays a valid OMB control number. The proposal contains a collection of information because of the proposed phase-in

reporting requirements. There is no burden to the general public.

The collection of information would require manufacturers of passenger cars and of trucks, buses and MPVs with a GVWR of 4,536 kg (10,000 lb) or less, to annually submit a report, and maintain records related to the report, concerning the number of such vehicles that meet the vehicle-to-pole test requirements of FMVSS No. 214 during the phase-in of those requirements. The phase-in of the vehicle-to-pole test requirements will be completed three years after publication of a final rule. The purpose of the reporting requirements is to aid the agency in determining whether a manufacturer of vehicles subject to the standard has complied with the vehicle-to-pole test requirements during the phase-in of those requirements.

We are submitting a request for OMB clearance of the collection of information required under today’s proposal. These requirements and our estimates of the burden to vehicle manufacturers are as follows:

- NHTSA estimates that there are 21 manufacturers of passenger cars, multipurpose passenger vehicles, trucks, and buses with a GVWR of 4,536 kg (10,000 lb) or less;
- NHTSA estimates that the total annual reporting and recordkeeping burden resulting from the collection of information is 1,260 hours;
- NHTSA estimates that the total annual cost burden, in U.S. dollars, will be \$0. No additional resources will be expended by vehicle manufacturers to gather annual production information because they already compile this data for their own use.

Under the PRA, the agency must publish a document in the **Federal Register** providing a 60-day comment period and otherwise consult with members of the public and affected agencies concerning each collection of information. The Office of Management and Budget (OMB) has promulgated regulations describing what must be included in such a document. Under OMB’s regulations (5 CFR 320.8(d)), agencies must ask for public comment on the following:

- (1) Whether the collection of information is necessary for the proper performance of the functions of the agency, including whether the information will have practical utility;
- (2) The accuracy of the agency’s estimate of the burden of the proposed collection of information, including the validity of the methodology and assumptions used;
- (3) How to enhance the quality, utility, and clarity of the information to be collected; and,

(4) How to minimize the burden of the collection of information on those who are to respond, including the use of appropriate automated, electronic, mechanical, or other technological collection techniques or other forms of information technology, *e.g.*, permitting electronic submission of responses.

Organizations and individuals that wish to submit comments on the information collection requirements should direct them to NHTSA's docket for this NPRM.

#### *i. National Technology Transfer and Advancement Act*

Under the National Technology Transfer and Advancement Act of 1995 (NTTAA) (Pub. L. 104-113),

all Federal agencies and departments shall use technical standards that are developed or adopted by voluntary consensus standards bodies, using such technical standards as a means to carry out policy objectives or activities determined by the agencies and departments.

Voluntary consensus standards are technical standards (*e.g.*, materials specifications, test methods, sampling procedures, and business practices) that are developed or adopted by voluntary consensus standards bodies, such as the International Organization for Standardization (ISO) and the Society of Automotive Engineers. The NTTAA directs us to provide Congress, through OMB, explanations when we decide not to use available and applicable voluntary consensus standards.

When NHTSA developed the vehicle-to-pole test that was adopted into FMVSS No. 201, the agency based the test on a proposed ISO test procedure found in ISO/SC10/WG1 (October 2001). In developing today's NPRM, we considered the draft ISO standard and ISO draft technical reports related to side air bags performance to guide our decision-making to the extent consistent with the Safety Act. The notable differences between the draft ISO standard and this proposal relate to: The diameter of the pole (ISO draft technical reports recommend the use of 350 mm pole, while NHTSA uses a 254 mm pole in FMVSS No. 201 and would use such a pole in FMVSS No. 214), and the angle of approach of the test vehicle to the pole (ISO specifies 90 degrees, while our NPRM proposes to use a 75 degree angle). The agency's reasons for proposing a 254 mm pole and an oblique, 32 km/h (20 mph), angle of approach were discussed earlier in this document.

## **XII. Public Participation**

### *How Can I Influence NHTSA's Thinking on This Proposed Rule?*

In developing this proposal, we tried to address the concerns of all our stakeholders. Your comments will help us improve this proposed rule. We invite you to provide different views on options we propose, new approaches we haven't considered, new data, how this proposed rule may affect you, or other relevant information. We welcome your views on all aspects of this proposed rule, but request comments on specific issues throughout this document. Your comments will be most effective if you follow the suggestions below:

- Explain your views and reasoning as clearly as possible.
- Provide solid technical and cost data to support your views.
- If you estimate potential costs, explain how you arrived at the estimate.
- Tell us which parts of the proposal you support, as well as those with which you disagree.
- Provide specific examples to illustrate your concerns.
- Offer specific alternatives.
- Refer your comments to specific sections of the proposal, such as the units or page numbers of the preamble, or the regulatory sections.
- Be sure to include the name, date, and docket number with your comments.

### *How Do I Prepare and Submit Comments?*

Your comments must be written and in English. To ensure that your comments are correctly filed in the Docket, please include the docket number of this document in your comments.

Your comments must not be more than 15 pages long (49 CFR 553.21). We established this limit to encourage you to write your primary comments in a concise fashion. However, you may attach necessary additional documents to your comments. There is no limit on the length of the attachments.

Please submit two copies of your comments, including the attachments, to Docket Management at the address given above under **ADDRESSES**.

Comments may also be submitted to the docket electronically by logging onto the Dockets Management System Web site at Click on "Help & Information" or "Help/Info" to obtain instructions for filing the document electronically.

### *How Can I Be Sure That My Comments Were Received?*

If you wish Docket Management to notify you upon its receipt of your

comments, enclose a self-addressed, stamped postcard in the envelope containing your comments. Upon receiving your comments, Docket Management will return the postcard by mail.

### *How Do I Submit Confidential Business Information?*

If you wish to submit any information under a claim of confidentiality, you should submit three copies of your complete submission, including the information you claim to be confidential business information, to the Chief Counsel, NHTSA, at the address given above under **FOR FURTHER INFORMATION CONTACT**. In addition, you should submit two copies, from which you have deleted the claimed confidential business information, to Docket Management at the address given above under **ADDRESSES**. When you send a comment containing information claimed to be confidential business information, you should include a cover letter setting forth the information specified in our confidential business information regulation. (49 CFR part 512.)

### *Will the Agency Consider Late Comments?*

We will consider all comments that Docket Management receives before the close of business on the comment closing date indicated above under **DATES**. To the extent possible, we will also consider comments that Docket Management receives after that date. If Docket Management receives a comment too late for us to consider it in developing a final rule (assuming that one is issued), we will consider that comment as an informal suggestion for future rulemaking action.

### *How Can I Read the Comments Submitted by Other People?*

You may read the comments received by Docket Management at the address given above under **ADDRESSES**. The hours of the Docket are indicated above in the same location.

You may also see the comments on the Internet. To read the comments on the Internet, take the following steps:

(1) Go to the Docket Management System (DMS) Web page of the Department of Transportation (<http://dms.dot.gov/>).

(2) On that page, click on "search."

(3) On the next page (<http://dms.dot.gov/search/>), type in the four-digit docket number shown at the beginning of this document. Example: If the docket number were "NHTSA-2002-1234," you would type "1234."

After typing the docket number, click on "search."

(4) On the next page, which contains docket summary information for the docket you selected, click on the desired comments. You may download the comments. However, since the comments are imaged documents, instead of word processing documents, the downloaded comments are not word searchable.

Please note that even after the comment closing date, we will continue to file relevant information in the Docket as it becomes available. Further, some people may submit late comments. Accordingly, we recommend that you periodically check the Docket for new material. Upon receiving the comments, the docket supervisor will return the postcard by mail.

Anyone is able to search the electronic form of all comments received into any of our dockets by the name of the individual submitting the comment (or signing the comment, if submitted on behalf of an association, business, labor union, *etc.*). You may review DOT's complete Privacy Act Statement in the **Federal Register** published on April 11, 2000 (Volume 65, Number 70; Pages 19477-78) or you may visit <http://dms.dot.gov>.

## Appendix A—Glossary

### Categories of Side Air Bags

*Combined (also called "integrated" or "combo") side air bag system.* Incorporates both a head air bag system and a torso side air bag into one unit that is typically installed in the seat back.

*Curtain.* A "curtain" type side air bag system (referred to as "curtain bags," window curtains, or air curtains, AC). A curtain is an inflatable device that is fixed at two points, one at the front end of the vehicle's A-pillar and the other along the roof rail near the C-pillar. It is installed under the roof rail headliner. This system would provide head and neck protection for front and possibly rear seat occupants in outboard seating positions in side crashes. The curtain air bags can be designed to provide extended inflation time (compared to frontal air bags), which could provide occupant protection during vehicle rollovers (when deployed).

*Head air bag system (or head protection system (HPS)).* The term comprises different types of head protection systems, such as curtain bags or ITS, installed either as a stand alone system or combined with a thorax side air bag.

*Inflatable Tubular Structure (ITS).* The ITS is an inflatable device that is fixed at two points, one at the front end of the vehicle's A-pillar and the other at the back end to the roof rail behind the B-pillar. It is installed under the roof rail headliner. When deployed, the ITS inflates to become a self supporting tube that spans the vehicle's side window diagonally and provides head and neck protection. The ITS remains inflated for

a few seconds and can provide some additional protection during rollover events and secondary impacts.

*Side impact air bag (SIAB).* The term refers to side air bags generally.

*Torso (or thorax) side air bag.* A "torso" (or "thorax") side air bag that can be installed in either the seat back or the vehicle door. As the name indicates, the system would provide protection for the torso but not for the head.

### List of Subjects

#### 49 CFR Part 571

Imports, Incorporation by reference, Motor vehicle safety, Reporting and recordkeeping requirements, Tires.

#### 49 CFR Part 598

Motor vehicle safety, Reporting and recordkeeping requirements.

In consideration of the foregoing, NHTSA proposes to amend 49 CFR chapter V as set forth below.

## PART 571—FEDERAL MOTOR VEHICLE SAFETY STANDARDS

1. The authority citation for Part 571 would continue to read as follows:

**Authority:** 49 U.S.C. 322, 30111, 30115, 30117 and 30166; delegation of authority at 49 CFR 1.50.

2. Section 571.201 would be amended by revising S6.1(b)(3) and S6.2(b)(3), and adding S6.1(b)(4) and S6.2(b)(4) to read as follows:

### § 571.201 Standard No. 201; Occupant protection in interior impact.

\* \* \* \* \*

S6.1 *Vehicles manufactured on or after September 1, 1998.* \* \* \*

(b) \* \* \*

(3) Except as provided in S6.1(b)(4), each vehicle shall, when equipped with a dummy test device specified in 49 CFR part 572, subpart M, and tested as specified in S8.16 through S8.28, comply with the requirements specified in S7 when crashed into a fixed, rigid pole of 254 mm in diameter, at any velocity between 24 kilometers per hour (15 mph) and 29 kilometers per hour (18 mph).

(4) Vehicles certified as complying with the vehicle-to-pole requirements of S9.2.1, S9.2.2 and S9.2.3 of 49 CFR 571.214, *Side Impact Protection*, need not comply with the requirements specified in S7 of this section.

\* \* \* \* \*

S6.2 *Vehicles manufactured on or after September 1, 2002 and vehicles built in two or more stages manufactured after September 1, 2006.*

\* \* \*

(b) \* \* \*

(3) Except as provided in S6.2(b)(4), each vehicle shall, when equipped with

a dummy test device specified in 49 CFR part 572, subpart M, and tested as specified in S8.16 through S8.28, comply with the requirements specified in S7 when crashed into a fixed, rigid pole of 254 mm in diameter, at any velocity between 24 kilometers per hour (15 mph) and 29 kilometers per hour (18 mph).

(4) Vehicles certified as complying with the vehicle-to-pole requirements of S9.2.1, S9.2.2 and S9.2.3 of 49 CFR 571.214, *Side Impact Protection*, need not comply with the requirements specified in S7 of this section.

\* \* \* \* \*

3. Section 571.214 would be revised to read as follows:

### § 571.214 Standard No. 214; Side impact protection.

S1 *Scope and purpose.*

(a) *Scope.* This standard specifies performance requirements for protection of occupants in side impacts.

(b) *Purpose.* The purpose of this standard is to reduce the risk of serious and fatal injury to occupants of passenger cars, multipurpose passenger vehicles, trucks and buses in side impacts by specifying strength requirements for side doors, limiting the forces, deflections and accelerations measured on anthropomorphic dummies in test crashes, and by other means.

S2 *Applicability.* This standard applies to passenger cars, and to multipurpose passenger vehicles, trucks and buses with a gross vehicle weight rating (GVWR) of 4,536 kilograms (kg) (10,000 pounds (lb)) or less, except for walk-in vans, or otherwise specified.

S3 *Definitions.*

*Altered roof* is used as defined in paragraph S4 of 49 CFR 571.216.

*Contoured* means, with respect to a door, that the lower portion of its front or rear edge is curved upward, typically to conform to a wheel well.

*Double side doors* means a pair of hinged doors with the lock and latch mechanisms located where the door lips overlap.

*Limited line manufacturer* means a manufacturer that sells three or fewer carlines, as that term is defined in 49 CFR 585.4, in the United States during a production year.

*Raised roof* is used as defined in paragraph S4 of 49 CFR 571.216.

*Walk-in van* means a special cargo/mail delivery vehicle that has only one designated seating position. That designated seating position must be forward facing and for use only by the driver. The vehicle usually has a thin and light sliding (or folding) side door for easy operation and a high roof

clearance that a person of medium stature can enter the passenger compartment area in an up-right position.

**S4 Requirements.** Subject to the exceptions of S5—

(a) *Passenger cars.* Passenger cars must meet the requirements set forth in S6 (door crush resistance), S7 (moving deformable barrier test), and S9 (vehicle-to-pole test), subject to the phased-in application of S9.

(b) *Multipurpose passenger vehicles, trucks and buses with a GVWR of 2,722 kg or less (6,000 lb or less).*

Multipurpose passenger vehicles, trucks and buses with a GVWR of 2,722 kg or less, (6,000 lb or less) must meet the requirements set forth in S6 (door crush resistance), S7 (moving deformable barrier test), and S9 (vehicle-to-pole test), subject to the phased-in application of S9.

(c) *Multipurpose passenger vehicles, trucks and buses with a GVWR greater than 2,722 kg (6,000 lb).* Multipurpose passenger vehicles, trucks and buses with a GVWR greater than 2,722 kg (6,000 lb) must meet the requirements set forth in S6 (door crush resistance) and S9 (vehicle-to-pole test), subject to the phased-in application of S9.

**S5 General exclusions.**

(a) *Exclusions from S6 (door crush resistance).* A vehicle need not meet the requirements of S6 (door crush resistance) for—

(1) Any side door located so that no point on a ten-inch horizontal longitudinal line passing through and bisected by the H-point of a manikin placed in any seat, with the seat adjusted to any position and the seat back adjusted as specified in S8.4, falls within the transverse, horizontal projection of the door's opening,

(2) Any side door located so that no point on a ten-inch horizontal longitudinal line passing through and bisected by the H-point of a manikin placed in any seat recommended by the manufacturer for installation in a location for which seat anchorage hardware is provided, with the seat adjusted to any position and the seat back adjusted as specified in S8.3, falls within the transverse, horizontal projection of the door's opening,

(3) Any side door located so that a portion of a seat, with the seat adjusted to any position and the seat back adjusted as specified in S8.3, falls within the transverse, horizontal protection of the door's opening, but a longitudinal vertical plane tangent to the outboard side of the seat cushion is more than 254 mm (10 inches) from the innermost point on the inside surface of the door at a height between the H-point

and shoulder reference point (as shown in Figure 1 of Federal Motor Vehicle Safety Standard No. 210 (49 CFR 571.210)) and longitudinally between the front edge of the cushion with the seat adjusted to its forwardmost position and the rear edge of the cushion with the seat adjusted to its rearmost position.

(4) Any side door that is designed to be easily attached to or removed (e.g., using simple hand tools such as pliers and/or a screwdriver) from a motor vehicle manufactured for operation without doors.

(b) *Exclusions from S7 (moving deformable barrier test).* The following vehicles are excluded from S7 (moving deformable barrier test):

(1) Motor homes, tow trucks, dump trucks, ambulances and other emergency rescue/medical vehicles (including vehicles with fire-fighting equipment), vehicles equipped with wheelchair lifts, and vehicles which have no doors or exclusively have doors that are designed to be easily attached or removed so the vehicle can be operated without doors.

(2) Passenger cars with a wheelbase greater than 130 inches need not meet the requirements of S7 as applied to the rear seat.

(3) Passenger cars, multipurpose passenger vehicles, trucks and buses need not meet the requirements of S7 (moving deformable barrier test) as applied to the rear seat for side-facing rear seats and for rear seating areas that are so small that a part 572 subpart [subpart number to be determined] dummy representing a 5th percentile female cannot be accommodated according to the positioning procedure specified in S12.3.4 of this standard.

(4) Multipurpose passenger vehicles, trucks and buses with a GVWR of more than 2,722 kg (more than 6,000 lb) need not meet the requirements of S7 (moving deformable barrier test).

(c) *Exclusions from S9 (vehicle-to-pole test).* The following vehicles are excluded from S9 (vehicle-to-pole test):

(1) Motor homes;

(2) Tow trucks;

(3) Dump trucks;

(4) Ambulances and other emergency rescue/medical vehicles (including vehicles with fire-fighting equipment);

(5) Vehicles equipped with wheelchair lifts,

(6) Vehicles with a raised roof or altered roof; and

(7) Vehicles which have no doors, or exclusively have doors that are designed to be easily attached or removed so that the vehicle can be operated without doors.

**S6 Door crush resistance requirements.** Except as provided in section S5, each vehicle shall be able to meet the requirements of either, at the manufacturer's option, S6.1 or S6.2, when any of its side doors that can be used for occupant egress is tested according to procedures described in S6.3 of this standard (49 CFR 571.214).

S6.1 With any seats that may affect load upon or deflection of the side of the vehicle removed from the vehicle, each vehicle must be able to meet the requirements of S6.1.1 through S6.1.3.

S6.1.1 *Initial crush resistance.* The initial crush resistance shall not be less than 10,000 N (2,250 lb).

S6.1.2 *Intermediate crush resistance.* The intermediate crush resistance shall not be less than 1,557 N (3,500 lb).

S6.1.3 *Peak crush resistance.* The peak crush resistance shall not be less than two times the curb weight of the vehicle or 3,114 N (7,000 lb), whichever is less.

S6.2 With seats installed in the vehicle, and located in any horizontal or vertical position to which they can be adjusted and at any seat back angle to which they can be adjusted, each vehicle must be able to meet the requirements of S6.2.1 through S6.2.3.

S6.2.1 *Initial crush resistance.* The initial crush resistance shall not be less than 10,000 N (2,250 lb).

S6.2.2 *Intermediate crush resistance.* The intermediate crush resistance shall not be less than 1,946 N (4,375 lb).

S6.2.3 *Peak crush resistance.* The peak crush resistance shall not be less than three and one half times the curb weight of the vehicle or 5,338 N (12,000 lb), whichever is less.

S6.3 *Test procedures for door crush resistance.* The following procedures apply to determining compliance with S6.1 and S6.2 of S6, *Door crush resistance requirements.*

(a) Place side windows in their uppermost position and all doors in locked position. Place the sill of the side of the vehicle opposite to the side being tested against a rigid unyielding vertical surface. Fix the vehicle rigidly in position by means of tiedown attachments located at or forward of the front wheel centerline and at or rearward of the rear wheel centerline.

(b) Prepare a loading device consisting of a rigid steel cylinder or semi-cylinder 305 mm (12 inches) in diameter with an edge radius of 13 mm (½inch). The length of the loading device shall be such that—

(1) For doors with windows, the top surface of the loading device is at least 13 mm (½inch) above the bottom edge

of the door window opening but not of a length that will cause contact with any structure above the bottom edge of the door window opening during the test.

(2) For doors without windows, the top surface of the loading device is at the same height above the ground as when the loading device is positioned in accordance with paragraph (b)(1) of this section for purposes of testing a front door with windows on the same vehicle.

(c) Locate the loading device as shown in Figure 1 (side view) of this section so that—

(1) Its longitudinal axis is vertical.

(2) Except as provided in paragraphs (c)(2)(i) and (ii) of this section, its longitudinal axis is laterally opposite the midpoint of a horizontal line drawn across the outer surface of the door 127 mm (5 inches) above the lowest point of the door, exclusive of any decorative or protective molding that is not permanently affixed to the door panel.

(i) For contoured doors on trucks, buses, and multipurpose passenger vehicles with a GVWR of 4,536 kg (10,000 lb) or less, if the length of the horizontal line specified in this paragraph (c)(2) is not equal to or greater than 559 mm (22 inches), the line is moved vertically up the side of the door to the point at which the line is 559 mm (22 inches) long. The longitudinal axis of the loading device is then located laterally opposite the midpoint of that line.

(ii) For double side doors on trucks, buses, and multipurpose passenger vehicles with a GVWR of 4,536 kg (10,000 lb) or less, its longitudinal axis

is laterally opposite the midpoint of a horizontal line drawn across the outer surface of the double door span, 127 mm (5 inches) above the lowest point on the doors, exclusive of any decorative or protective molding that is not permanently affixed to the door panel.

(3) Except as provided in paragraphs (c)(3)(i) and (ii) of this section, its bottom surface is in the same horizontal plane as the horizontal line drawn across the outer surface of the door 127 mm (5 inches) above the lowest point of the door, exclusive of any decorative or protective molding that is not permanently affixed to the door panel.

(i) For contoured doors on trucks, buses, and multipurpose passenger vehicles with a GVWR of 4,536 kg (10,000 lb) or less, its bottom surface is in the lowest horizontal plane such that every point on the lateral projection of the bottom surface of the device on the door is at least 127 mm (5 inches), horizontally and vertically, from any edge of the door panel, exclusive of any decorative or protective molding that is not permanently affixed to the door panel.

(ii) For double side doors, its bottom surface is in the same horizontal plane as a horizontal line drawn across the outer surface of the double door span, 127 mm (5 inches) above the lowest point of the doors, exclusive of any decorative or protective molding that is not permanently affixed to the door panel.

(d) Using the loading device, apply a load to the outer surface of the door in an inboard direction normal to a vertical plane along the vehicle's longitudinal

centerline. Apply the load continuously such that the loading device travel rate does not exceed 12.7 mm (0.5 inch) per second until the loading device travels 457 mm (18 inches). Guide the loading device to prevent it from being rotated or displaced from its direction of travel. The test must be completed within 120 seconds.

(e) Record applied load versus displacement of the loading device, either continuously or in increments of not more than 25.4 mm (1 inch) or 91 kg (200 pounds) for the entire crush distance of 457 mm (18 inches).

(f) Determine the initial crush resistance, intermediate crush resistance, and peak crush resistance as follows:

(1) From the results recorded in paragraph (e) of this section, plot a curve of load versus displacement and obtain the integral of the applied load with respect to the crush distances specified in paragraphs (f) (2) and (3) of this section. These quantities, expressed in mm-kN (inch-pounds) and divided by the specified crush distances, represent the average forces in pounds required to deflect the door those distances.

(2) The initial crush resistance is the average force required to deform the door over the initial 152 mm (6 inches) of crush.

(3) The intermediate crush resistance is the average force required to deform the door over the initial 305 mm (12 inches) of crush.

(4) The peak crush resistance is the largest force recorded over the entire 457 mm (18-inch) crush distance.

**BILLING CODE 4910-59-P**



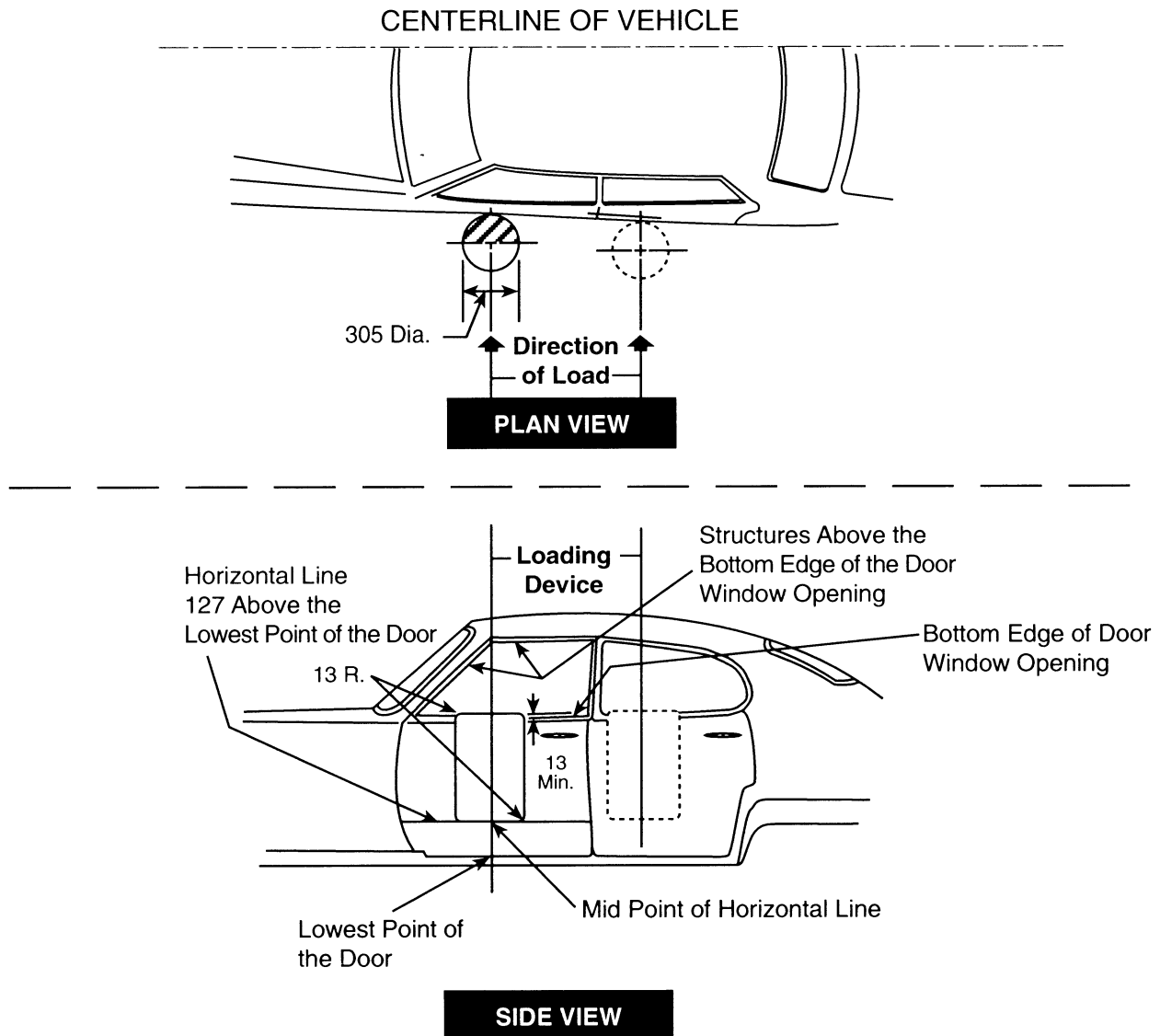

**Figure 1—LOADING DEVICE LOCATION AND APPLICATION TO THE DOOR**  
All dimensions in millimeters (mm)

**BILLING CODE 4910-59-C**

*S7 Moving Deformable Barrier Requirements.* Except as provided in section S5, when tested under the conditions of S8 each vehicle shall meet the following requirements in a  $53 \pm 1.0$  km/h (33.5 mph) impact in which the vehicle is struck on either side by a moving deformable barrier.

*S7.1 Vehicles manufactured before [four years from the publication date of the final rule. For illustration purposes, assume that the 4-year date is September 1, 2009].* For vehicles manufactured before September 1, 2009, the test dummy specified in 49 CFR part 572, subpart F (SID) is placed in the

front and rear outboard seating positions on the struck side of the vehicle, as specified in S11 and S12 of this standard (49 CFR 571.214). (Vehicles manufactured before September 1, 2009 may meet S7.2, at the manufacturer's option.) When using the part 572, subpart F dummy, the following performance requirements must be met.

(a) *Thorax.* The Thoracic Trauma Index (TTI(d)) shall not exceed:

- (1) 85 g for a passenger car with four side doors, and for any multipurpose passenger vehicle, truck, or bus; and,
- (2) 90 g for a passenger car with two side doors, when calculated in accordance with the following formula:

$$TTI(d) = \frac{1}{2}(G_R + G_{LS})$$

Where the term “ $G_R$ ” is the greater of the peak accelerations of either the upper or lower rib, expressed in g’s and the term “ $G_{LS}$ ” is the lower spine (T12) peak acceleration, expressed in g’s. The peak acceleration values are obtained in accordance with the procedure specified in S11.5.

(b) *Pelvis.* The peak lateral acceleration of the pelvis, as measured in accordance with S11.5, shall not exceed 130 g’s.

*S7.2 Vehicles manufactured on or after September 1, 2009.* Vehicles manufactured on or after September 1,

2009 must meet the requirements in S7.2.1 and S7.2.2 when tested with the test dummy specified in those sections. The agency has the option of using either dummy in its compliance test. The test dummy specified in S7.2.1 or S7.2.2 is placed and positioned in the front and rear outboard seating positions on the struck side of the vehicle, as specified in S11 and S12 of this standard (49 CFR 571.214).

**S7.2.1 Dynamic performance requirements using the part 572 subpart [to be determined] dummy (ES-2re 50th percentile male) dummy.** Use the part 572 subpart [to be determined] ES-2re dummy specified in S11 with measurements in accordance with S11.5.

(a) The HIC shall not exceed 1000 when calculated in accordance with the following formula:

$$\text{HIC} = \left[ \frac{1}{(t_2 - t_1)} \int_{t_1}^{t_2} a dt \right]^{2.5} (t_2 - t_1)$$

Where the term  $a$  is the resultant head acceleration at the center of gravity of the dummy head expressed as a multiple of  $g$  (the acceleration of gravity), and  $t_1$  and  $t_2$  are any two points in time during the impact which are separated by not more than a 36 millisecond time interval and where  $t_1$  is less than  $t_2$ .

(b) Thorax. The deflection of any of the upper, middle, and lower ribs, shall not exceed 42 mm (1.65 inches).

(c) The resultant lower spine acceleration must not exceed 82  $g$ .

(d) Force measurements.

(1) The sum of the front, middle and rear abdominal forces, shall not exceed 2,500 N (562 lb).

(2) The pubic symphysis force shall not exceed 6,000 N (1,350 pounds).

**S7.2.2 Dynamic performance requirements using the Part 572 Subpart [to be determined] (SID-IIsFRG 5th percentile female) dummy.** Use the Part 572 Subpart [to be determined] SID-IIsFRG 5th percentile female dummy specified in S11 with measurements in accordance with S11.5.

(a) The HIC shall not exceed 1000 when calculated in accordance with the following formula:

$$\text{HIC} = \left[ \frac{1}{(t_2 - t_1)} \int_{t_1}^{t_2} a dt \right]^{2.5} (t_2 - t_1)$$

Where the term  $a$  is the resultant head acceleration expressed as a multiple of  $g$  (the acceleration of gravity), and  $t_1$  and  $t_2$  are any two points in time during the impact which are separated by not more than a 36 millisecond time interval.

(b) The resultant lower spine acceleration shall not exceed 82  $g$ .

(c) The sum of the acetabular and iliac pelvic forces shall not exceed 5,100 N (1,147 lb).

**S7.3 Door opening.**

(a) Any side door that is struck by the moving deformable barrier shall not separate totally from the vehicle.

(b) Any door (including a rear hatchback or tailgate) that is not struck by the moving deformable barrier shall meet the following requirements:

(1) The door shall not disengage from the latched position;

(2) The latch shall not separate from the striker, and the hinge components shall not separate from each other or from their attachment to the vehicle.

(3) Neither the latch nor the hinge systems of the door shall pull out of their anchorages.

**S8. Test conditions for determining compliance with moving deformable barrier requirements.** General test conditions for determining compliance with the moving deformable barrier test are specified below. Additional specifications may also be found in S12 of this standard (49 CFR 571.214).

**S8.1 Test weight.** Each vehicle is loaded to its unloaded vehicle weight, plus 136 kg (300 pounds) or its rated cargo and luggage capacity (whichever is less), secured in the luggage or load-carrying area, plus the weight of the necessary anthropomorphic test dummies. Any added test equipment is located away from impact areas in secure places in the vehicle. The vehicle's fuel system is filled in accordance with the following procedure. With the test vehicle on a level surface, pump the fuel from the vehicle's fuel tank and then operate the engine until it stops. Then, add Stoddard solvent to the test vehicle's fuel tank in an amount that is equal to not less than 92 percent and not more than 94 percent of the fuel tank's usable capacity stated by the vehicle's manufacturer. In addition, add the amount of Stoddard solvent needed to fill the entire fuel system from the fuel tank through the engine's induction system.

**S8.2 Vehicle test attitude.** When the vehicle is in its "as delivered," "fully loaded" and "as tested" condition, locate the vehicle on a flat, horizontal surface to determine the vehicle attitude. Use the same level surface or reference plane and the same standard points on the test vehicle when determining the "as delivered," "fully loaded" and "as tested" conditions. Measure the angles relative to a horizontal plane, front-to-rear and from left-to-right for the "as delivered,"

"fully loaded," and "as tested" conditions. The front-to-rear angle (pitch) shall be measured along a fixed reference on the driver's and front passenger's door sill. Mark where the angles are taken on the door sill. The left to right angle (roll) is measured along a fixed reference point at the front and rear of the vehicle at the vehicle longitudinal center plane. Mark where the angles are measured. The "as delivered" condition is the vehicle as received at the test site, with 100 percent of all fluid capacities and all tires inflated to the manufacturer's specifications listed on the vehicle's tire placard. When the vehicle is in its "fully loaded" condition, measure the angle between the driver's door sill and the horizontal, at the same place the "as delivered" angle was measured. The "fully loaded condition" is the test vehicle loaded in accordance with S8.1 of this standard (49 CFR 571.214). The load placed in the cargo area is centered over the longitudinal centerline of the vehicle. The vehicle "as tested" pitch and roll angles are between the "as delivered" and "fully loaded" condition, inclusive.

**S8.3 Adjustable seats.**

**S8.3.1 50th Percentile Male Dummy In Front Seats.**

**S8.3.1.1 Lumbar support adjustment.** Position adjustable lumbar supports so that the lumbar support is in its lowest, retracted or deflated adjustment position.

**S8.3.1.2 Other seat adjustments.** Position any adjustable parts of the seat that provide additional support so that they are in the lowest or non-deployed adjustment position. Position any adjustable head restraint in the lowest and most forward position.

**S8.3.1.3 Seat position adjustment.** If the passenger seat does not adjust independently of the driver seat, the driver seat shall control the final position of the passenger seat.

**S8.3.1.3.1 Using only the controls that primarily move the seat and seat cushion independent of the seat back in the fore and aft directions, move the seat cushion reference point (SCRCP) to the rearmost position. Using any part of any control, other than those just used, determine the full range of angles of the seat cushion reference line and set the seat cushion reference line to the middle of the range. Using any part of any control other than those that primarily move the seat or seat cushion fore and aft, while maintaining the seat cushion reference line angle, place the SCRCP to its lowest position.**

**S8.3.1.3.2 Using only the control that primarily moves the seat fore and aft, move the seat cushion reference**

point to the mid travel position. If an adjustment position does not exist midway between the forwardmost and rearmost positions, the closest adjustment position to the rear of the midpoint is used.

S8.3.1.3.3 If the seat or seat cushion height is adjustable, other than by the controls that primarily move the seat or seat cushion fore and aft, set the height of the seat cushion reference point to the minimum height, with the seat cushion reference line angle set as closely as possible to the angle determined in S8.3.1.3.1. Mark location of the seat for future reference.

S8.3.2. *5th Percentile Female Dummy In Front Seats.*

S8.3.2.1 *Lumbar support adjustment.* Position adjustable lumbar supports so that the lumbar support is in its lowest, retracted or deflated adjustment position.

S8.3.2.2 *Other seat adjustments.* Position any adjustable parts of the seat that provide additional support so that they are in the lowest or non-deployed adjustment position. Position any adjustable head restraint in the lowest and most forward position.

S8.3.2.3 *Seat position adjustment.* If the passenger seat does not adjust independently of the driver seat, the driver seat shall control the final position of the passenger seat.

S8.3.2.3.1 Using only the controls that primarily move the seat and seat cushion independent of the seat back in the fore and aft directions, move the seat cushion reference point (SCRCP) to the rearmost position. Using any part of any control, other than those just used, determine the full range of angles of the seat cushion reference line and set the seat cushion reference line to the middle of the range. Using any part of any control other than those that primarily move the seat or seat cushion fore and aft, while maintaining the seat cushion reference line angle, place the SCRCP to its lowest position.

S8.3.2.3.2 Using only the control that primarily moves the seat fore and aft, move the seat reference point to the most forward position.

S8.3.2.3.3 If the seat or seat cushion height is adjustable, other than by the controls that primarily move the seat or seat cushion fore and aft, set the seat

reference point to the midpoint height, with the seat cushion reference line angle set as close as possible to the angle determined in S8.3.2.3.1. Mark location of the seat for future reference.

S8.3.3 *50th Percentile Male and 5th Percentile Female Dummies in Second Row Seat.*

S8.3.3.1 *Lumbar support adjustment.* Position adjustable lumbar supports so that the lumbar support is in its lowest, retracted or deflated adjustment position.

S8.3.3.2 *Other seat adjustments.* Position any adjustable parts of the seat that provide additional support so that they are in the lowest or non-deployed adjustment position. Position any adjustable head restraint in the lowest and most forward position.

S8.3.3.3 *Seat position adjustment.* Using only the controls that primarily move the seat and seat cushion independent of the seat back in the fore and aft directions, move the seat cushion reference point (SCRCP) to the rearmost position. Using any part of any control, other than those just used, determine the full range of angles of the seat cushion reference line and set the seat cushion reference line to the middle of the range. Using any part of any control other than those that primarily move the seat or seat cushion fore and aft, while maintaining the seat cushion reference line angle, place the SCRCP to its lowest position. Mark location of the seat for future reference.

S8.3.4 *Adjustable seat back placement.* When using the 50th percentile male dummy, adjustable seat backs are placed in the manufacturer's nominal design riding position in the manner specified by the manufacturer. If the position is not specified, set the seat back at the first detent rearward of 25 degrees from the vertical. Each adjustable head restraint is placed in its highest adjustment position. Adjustable seat back placement for the 5th percentile female dummy is specified in S12.3.

S8.4 *Adjustable steering wheel.* Adjustable steering controls are adjusted so that the steering wheel hub is at the geometric center of the locus it describes when it is moved through its full range of driving positions. If there is no setting detent in the mid-position,

lower the steering wheel to the detent just below the mid-position. If the steering column is telescoping, place the steering column in the mid-position. If there is no mid-position, move the steering wheel rearward one position from the mid-position.

S8.5 *Windows and sunroofs.* Movable vehicle windows and vents are placed in the fully closed position on the struck side of the vehicle. Any sunroof shall be placed in the fully closed position.

S8.6 *Convertible tops.* Convertibles and open-body type vehicles have the top, if any, in place in the closed passenger compartment configuration.

S8.7 *Doors.* Doors, including any rear hatchback or tailgate, are fully closed and latched but not locked.

S8.8 *Transmission and brake engagement.* For a vehicle equipped with a manual transmission, the transmission is placed in second gear. For a vehicle equipped with an automatic transmission, the transmission is placed in neutral. For all vehicles, the parking brake is engaged.

S8.9 *Moving deformable barrier.* The moving deformable barrier conforms to the dimensions shown in Figure 2 and specified in 49 CFR part 587.

S8.10 *Impact configuration.* The test vehicle (vehicle A in Figure 3) is stationary. The line of forward motion of the moving deformable barrier (vehicle B in Figure 3) forms an angle of 63 degrees with the centerline of the test vehicle. The longitudinal centerline of the moving deformable barrier is perpendicular to the longitudinal centerline of the test vehicle when the barrier strikes the test vehicle. In a test in which the test vehicle is to be struck on its left (right) side: All wheels of the moving deformable barrier are positioned at an angle of  $27 \pm 1$  degrees to the right (left) of the centerline of the moving deformable barrier; and the left (right) forward edge of the moving deformable barrier is aligned so that a longitudinal plane tangent to that side passes through the impact reference line within a tolerance of  $\pm 51$  mm (2 inches) when the barrier strikes the test vehicle.

BILLING CODE 4910-59-P

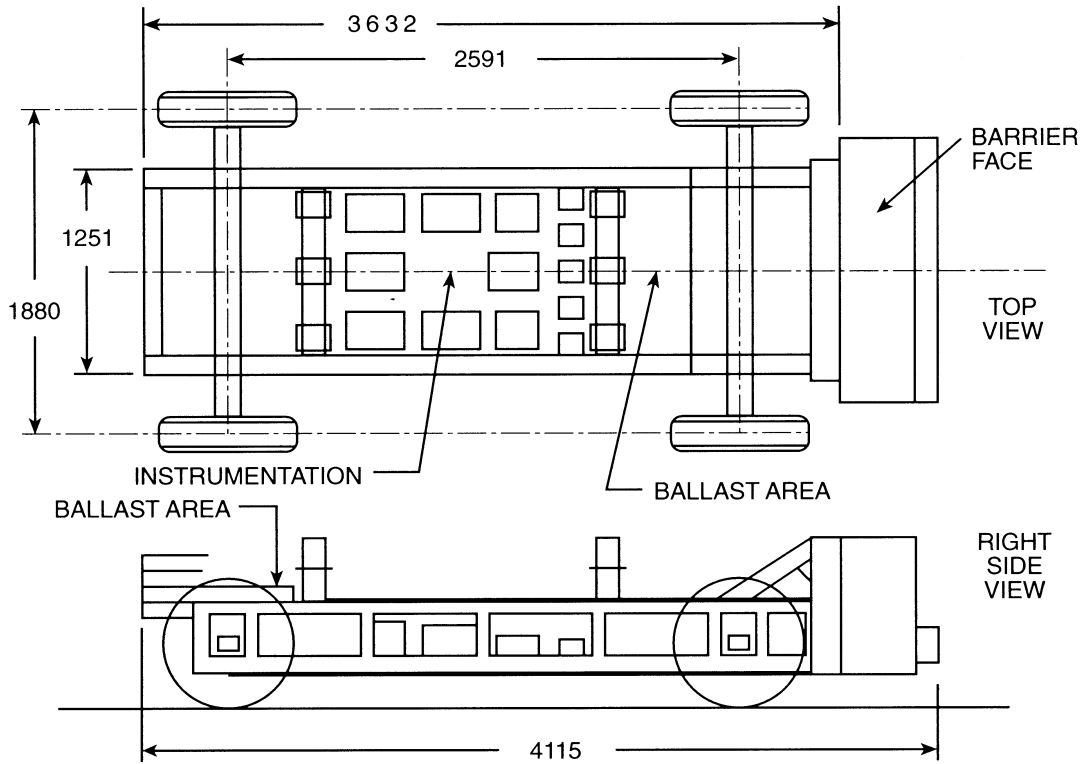

**NHTSA VEHICLE SIMULATOR**  
**All dimensions in millimeters (mm)**

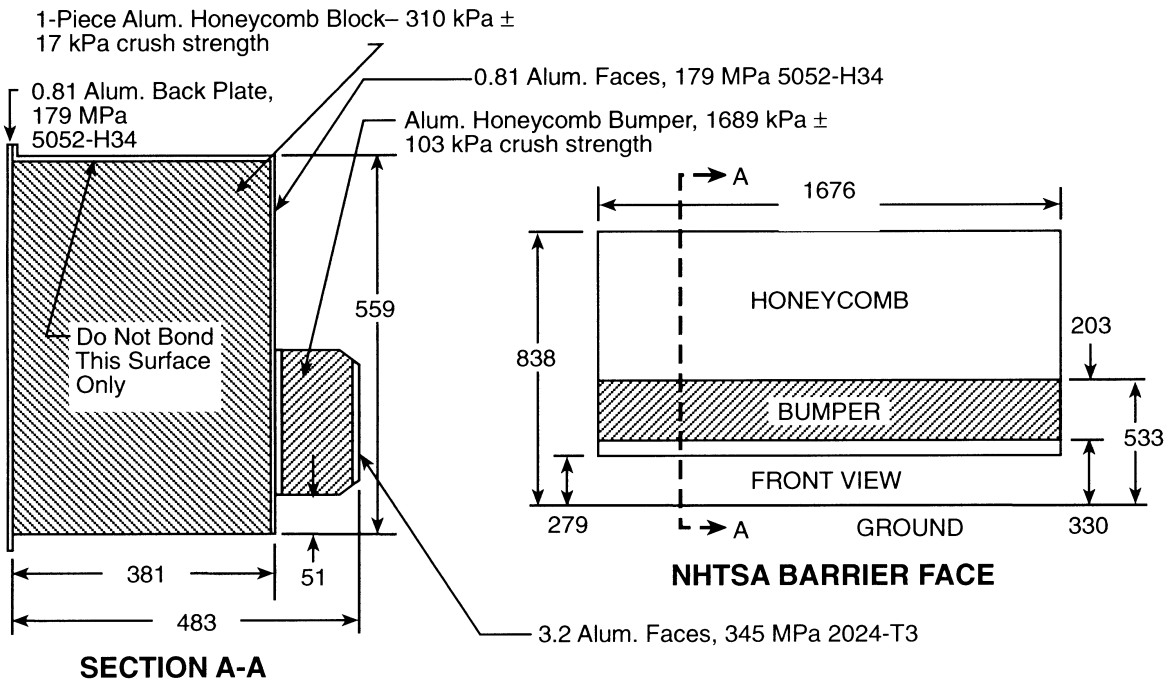

**Figure 2—NHTSA SIDE IMPACTOR – MOVING DEFORMABLE BARRIER**  
**All dimensions in millimeters (mm)**

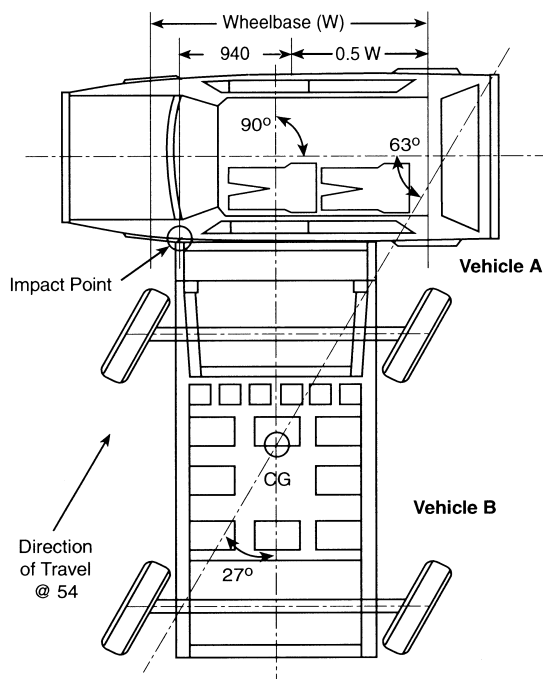

**Figure 3—TEST CONFIGURATION**  
All dimensions in millimeters (mm)  
velocity in km/h

**BILLING CODE 4910-59-C**

S8.11 *Impact reference line.* Place a vertical reference line at the location described below on the side of the vehicle that will be struck by the moving deformable barrier:

S8.11.1 *Passenger cars.*

(a) For vehicles with a wheelbase of 2,896 mm (114 inches) or less, 940 mm (37 inches) forward of the center of the vehicle's wheelbase.

(b) For vehicles with a wheelbase greater than 2,896 mm (114 inches), 508 mm (20 inches) rearward of the centerline of the vehicle's front axle.

S8.11.2 *Multipurpose passenger vehicles, trucks and buses.*

(a) For vehicles with a wheelbase of 2,489 mm (98 inches) or less, 305 mm (12 inches) rearward of the centerline of the vehicle's front axle, except as otherwise specified in paragraph (d) of this section.

(b) For vehicles with a wheelbase of greater than 2,489 mm (98 inches) but not greater than 2,896 mm (114 inches), 940 mm (37 inches) forward of the center of the vehicle's wheelbase, except as otherwise specified in paragraph (d) of this section.

(c) For vehicles with a wheelbase greater than 2,896 mm (114 inches), 508 mm (20 inches) rearward of the centerline of the vehicle's front axle, except as otherwise specified in paragraph (d) of this section.

(d) At the manufacturer's option, for different wheelbase versions of the same model vehicle, the impact reference line may be located by the following:

(1) Select the shortest wheelbase vehicle of the different wheelbase versions of the same model and locate on it the impact reference line at the location described in (a), (b) or (c) of this section, as appropriate;

(2) Measure the distance between the seating reference point (SgRP) and the impact reference line;

(3) Maintain the same distance between the SgRP and the impact reference line for the version being tested as that between the SgRP and the impact reference line for the shortest wheelbase version of the model.

(e) For the compliance test, the impact reference line will be located using the procedure used by the manufacturer as the basis for its certification of compliance with the requirements of this standard. If the manufacturer did not use any of the procedures in this section, or does not specify a procedure when asked by the agency, the agency may locate the impact reference line using either procedure.

S8.12 *Anthropomorphic test dummies.* The anthropomorphic test dummies used to evaluate a vehicle's performance in the moving deformable barrier test conform to the requirements of S11 and are positioned as described

in S12 of this standard (49 CFR 571.214).

S9. *Vehicle-to-Pole Requirements.*

S9.1 Except as provided in S5, when tested under the conditions of S10:

S9.1.1 Each vehicle manufactured on or after [date six years after the publication date of the final rule; for illustration purposes, assume that the 6-year date is September 1, 2011] must meet the requirements of S9.2.1, S9.2.2 and S9.2.3, when tested under the conditions specified in S10 into a fixed, rigid pole of 254 mm (10 inches) in diameter, at any speed up to and including 32 km/h (20 mph).

S9.1.2 Except as provided in S9.1.3 of this section, for vehicles manufactured on or after [date four years after the publication date of the final rule; for illustration purposes, assume that the 4-year date is September 1, 2009] to [date that is the August 31 that is six years after the publication date of the final rule; for illustration purposes, August 31, 2011], a percentage of each manufacturer's production, as specified in S13.1.1 and S13.1.2, shall meet the requirements of S9.2.1, S9.2.2 and S9.2.3 when tested under the conditions of S10 into a fixed, rigid pole of 254 mm (10 inches) in diameter, at any velocity up to and including 32 km/h (20 mph). Vehicles manufactured before September 1, 2011

may be certified as meeting the requirements specified in this section.

S9.1.3 The following vehicles are not subject to S9.1.2 of this section (but are subject to S9.1.1):

(a) Vehicles that are manufactured by an original vehicle manufacturer that produces or assembles fewer than 5,000 vehicles annually for sale in the United States;

(b) Vehicles that are altered (within the meaning of 49 CFR 567.7) after having been previously certified in accordance with part 567 of this chapter;

(c) Vehicles that are manufactured in two or more stages; and

(d) Vehicles that are manufactured by a limited line manufacturer.

## S9.2 Requirements.

S9.2.1 *Dynamic performance requirements using the Part 572 Subpart [to be determined] (ES-2re 50th percentile male) dummy.* Use the ES-2re part 572 subpart [to be determined] dummy, as specified in S11 of this standard (49 CFR 571.214). When using the dummy, the following performance requirements must be met using measurements in accordance with S11.5.

(a) The HIC shall not exceed 1000 when calculated in accordance with the following formula:

$$\text{HIC} = \left[ \frac{1}{(t_2 - t_1)} \int_{t_1}^{t_2} a dt \right]^{2.5} (t_2 - t_1)$$

Where the term  $a$  is the resultant head acceleration at the center of gravity of the dummy head expressed as a multiple of  $g$  (the acceleration of gravity), and  $t_1$  and  $t_2$  are any two points in time during the impact which are separated by not more than a 36 millisecond time interval and where  $t_1$  is less than  $t_2$ .

(b) Thorax. The deflection of any of the upper, middle, and lower ribs, shall not exceed 42 mm (1.65 inches).

(c) Resultant lower spine acceleration shall not exceed 82 g.

(d) Force measurements.

(1) The sum of the front, middle and rear abdominal forces, shall not exceed 2.5 kN (562 pounds).

(2) The pubic symphysis force shall not exceed 6.0 kN (1,350 pounds).

S9.2.2 *Dynamic performance requirements using the part 572 subpart [to be determined] (SID-IIsFRG 5th percentile female) dummy.* Use the SID-IIsFRG part 572 subpart [to be determined] dummy, as specified in S11 of this standard (49 CFR 571.214). When using the dummy, the following performance requirements must be met.

(a) The HIC shall not exceed 1000 when calculated in accordance with the following formula:

$$\text{HIC} = \left[ \frac{1}{(t_2 - t_1)} \int_{t_1}^{t_2} a dt \right]^{2.5} (t_2 - t_1)$$

Where the term  $a$  is the resultant head acceleration at the center of gravity of the dummy head expressed as a multiple of  $g$  (the acceleration of gravity), and  $t_1$  and  $t_2$  are any two points in time during the impact which are separated by not more than a 36 millisecond time interval and where  $t_1$  is less than  $t_2$ .

(b) Resultant lower spine acceleration must not exceed 82 g.

(c) The sum of the acetabular and iliac pelvic forces must not exceed 5,100 N (1,147 lb).

## S9.2.3 Door opening.

(a) Any side door that is struck by the pole shall not separate totally from the vehicle.

(b) Any door (including a rear hatchback or tailgate) that is not struck by the pole shall meet the following requirements:

(1) The door shall not disengage from the latched position; and

(2) The latch shall not separate from the striker, and the hinge components shall not separate from each other or from their attachment to the vehicle.

(3) Neither the latch nor the hinge systems of the door shall pull out of their anchorages.

S10. *General test conditions for determining compliance with vehicle-to-pole requirements.* General test conditions for determining compliance with the vehicle-to-pole test are specified below and in S12 of this standard (49 CFR 571.214).

S10.1 *Test weight.* Each vehicle shall be loaded as specified in S8.1 of this standard (49 CFR 571.214).

S10.2 *Vehicle test attitude.* The vehicle test attitude is determined as specified in S8.2 of this standard (49 CFR 571.214).

## S10.3 Adjustable seats.

S10.3.1 *Driver and front passenger seat set-up for 50th percentile male dummy.* The driver and front passenger seats are set up as specified in S8.3.1 of this standard, 49 CFR 571.214.

S10.3.2 *Driver and front passenger seat set-up for 5th percentile female dummy.* The driver and front passenger seats are set up as specified in S8.3.2 of this standard, 49 CFR 571.214.

## S10.4 Positioning dummies for the vehicle-to-pole test.

(a) *50th percentile male test dummy (ES-2re dummy).* The 50th percentile male test dummy shall be positioned in

the front outboard seating position on the struck side of the vehicle in accordance with the provisions of S12.2 of this standard, 49 CFR 571.214.

(b) *5th percentile female test dummy (SID-IIsFRG).* The 5th percentile female test dummy shall be positioned in the front outboard seating positions on the struck side of the vehicle in accordance with the provisions of S12.3 of this standard, 49 CFR 571.214.

S10.5 *Adjustable steering wheel.* Adjustable steering controls are adjusted so that the steering wheel hub is at the geometric center of the locus it describes when it is moved through its full range of driving positions. If there is no setting detent in the mid-position, lower the steering wheel to the detent just below the mid-position.

S10.6 *Windows and sunroofs.* Movable vehicle windows and vents are placed in the fully closed position on the struck side of the vehicle. Any sunroof shall be placed in the fully closed position.

S10.7 *Convertible tops.* Convertibles and open-body type vehicles have the top, if any, in place in the closed passenger compartment configuration.

S10.8 *Doors.* Doors, including any rear hatchback or tailgate, are fully closed and latched but not locked.

S10.9 *Transmission and brake engagement.* For a vehicle equipped with a manual transmission, the transmission is placed in second gear. For a vehicle equipped with an automatic transmission, the transmission is placed in neutral. For all vehicles, the parking brake is engaged.

S10.10 *Rigid pole.* The rigid pole is a vertical metal structure beginning no more than 102 millimeters (4 inches) above the lowest point of the tires on the striking side of the test vehicle when the vehicle is loaded as specified in S8.1 and extending above the highest point of the roof of the test vehicle. The pole is 254 mm (10 inches)  $\pm$  6 mm (0.25 in) in diameter and set off from any mounting surface, such as a barrier or other structure, so that the test vehicle will not contact such a mount or support at any time within 100 milliseconds of the initiation of vehicle to pole contact.

S10.11 *Impact reference line.* The impact reference line is located on the striking side of the vehicle at the intersection of the vehicle exterior and a vertical plane passing through the center of gravity of the head of the dummy seated in accordance with S12 in the front outboard designated seating position. The vertical plane forms an angle of 285 (or 75) degrees with the vehicle's longitudinal centerline for the right (or left) side impact test. The angle

is measured counterclockwise from the vehicle's positive X-axis as defined in S10.13.

**S10.12 Impact configuration.**

S10.12.1 The rigid pole is stationary.

S10.12.2 The test vehicle is propelled sideways so that its line of forward motion forms an angle of 285 (or 75) degrees ( $\pm 3$  degrees) for the right (or left) side impact with the vehicle's longitudinal centerline. The angle is measured counterclockwise from the vehicle's positive X-axis as defined in S10.13. The impact reference line is aligned with the center line of the rigid pole surface, as viewed in the direction of vehicle motion, so that, when the vehicle-to-pole contact occurs, the center line contacts the vehicle area bounded by two vertical planes parallel to and 38 mm (1.5 inches) forward and aft of the impact reference line.

S10.13 *Vehicle reference coordinate system.* The vehicle reference coordinate system is an orthogonal coordinate system consisting of three axes, a longitudinal axis (X), a transverse axis (Y), and a vertical axis (Z). X and Y are in the same horizontal plane and Z passes through the intersection of X and Y. The origin of the system is at the center of gravity of the vehicle. The X-axis is parallel to the longitudinal centerline of the vehicle and is positive to the vehicle front end and negative to the rear end. The Y-axis is positive to the left side of the vehicle and negative to the right side. The Z-axis is positive above the X-Y plane and negative below it.

S11. *Anthropomorphic test dummies.* The anthropomorphic test dummies used to evaluate a vehicle's performance in the moving deformable barrier and vehicle-to-pole tests are specified in 49 CFR part 572. In a test in which the test vehicle is to be struck on its left side, each dummy is to be configured and instrumented to be struck on its left side, in accordance with part 572. In a test in which the test vehicle is to be struck on its right side, each dummy is to be configured and instrumented to be struck on its right side, in accordance with part 572.

**S11.1 Clothing.**

(a) *50th percentile male.* Each test dummy representing a 50th percentile male is clothed in formfitting cotton stretch garments with short sleeves and midcalf length pants. Each foot of the test dummy is equipped with a size 11EEE shoe, which meets the configuration size, sole, and heel thickness specifications of MIL-S-13192 (1976) and weighs  $0.68 \pm 0.09$  kilograms ( $1.25 \pm 0.2$  lb).

(b) *5th percentile female.* The test dummy representing a 5th percentile

female is clothed in form fitting cotton stretch garments with short sleeves and about the knee length pants. Each foot has on a size 7.5W shoe that meets the configuration and size specifications of MIL-S-2171E or its equivalent.

**S11.2 Limb joints.**

(a) For the 50th percentile male dummy, set the limb joints at between 1 and 2 g. Adjust the leg joints with the torso in the supine position. Adjust the knee and ankle joints so that they just support the lower leg and the foot when extended horizontally (1 to 2 g adjustment).

(b) For the 5th percentile female dummy, set the limb joints at slightly above 1 g, barely restraining the weight of the limb when extended horizontally. The force needed to move a limb segment does not exceed 2 g throughout the range of limb motion. Adjust the leg joints with the torso in the supine position.

S11.3 The stabilized temperature of the test dummy at the time of the test is at any temperature between 20.6 degrees C and 22.2 degrees C.

**S11.4 Acceleration data.**

Accelerometers are installed on the head, rib, spine and pelvis components of various dummies as required to meet the injury criteria of the standard. Accelerations measured from different dummy components may use different filters and processing methods.

**S11.5 Processing Data.**

**(a) Subpart F test dummy.**

(1) Process the acceleration data from the accelerometers mounted on the ribs, spine and pelvis of the subpart F dummy with the FIR100 software specified in 49 CFR 572.44(d). Process the data in the following manner:

(i) Filter the data with a 300 Hz, SAE Class 180 filter;

(ii) Subsample the data to a 1600 Hz sampling rate;

(iii) Remove the bias from the subsampled data, and

(iv) Filter the data with the FIR100 software specified in 49 CFR 572.44(d), which has the following characteristics—

(A) Passband frequency 100 Hz.

(B) Stopband frequency 189 Hz.

(C) Stopband gain - 50 db.

(D) Passband ripple 0.0225 db.

(2) [Reserved]

(b) *Subpart [to be determined] (ES-2re) test dummy.*

(1) The chest and rib deflection data are filtered at channel frequency class 180 Hz. Abdominal and pubic force data are filtered at channel frequency class of 600 Hz.

(2) The acceleration data from the accelerometers installed inside the skull cavity of the ES-2re test dummy are

filtered at channel frequency class of 1000 Hz.

(3) The acceleration data from the accelerometers installed on the lower spine of the ES-2re test dummy are filtered at channel frequency class of 1000 Hz.

(c) *Subpart [to be determined] (SID-2sFRG) test dummy.* (5th percentile female)

(1) The acceleration data from the accelerometers installed inside the skull cavity of the SID IIsFRG test dummy are filtered at channel frequency class of 1000 Hz.

(2) The acceleration data from the accelerometers installed on the lower spine of the SID IIsFRG test dummy are filtered at channel frequency class of 180 Hz.

(3) The iliac and acetabular forces from load cells installed in the pelvis of the SID IIsFRG are filtered at channel frequency class of 600 Hz.

S12. *Positioning procedures for the anthropomorphic test dummies.*

S12.1 *50th percentile male test dummy—49 CFR part 572, subpart F (SID).* Position a correctly configured test dummy, conforming to the applicable requirements of part 572, subpart F of this chapter, in the front outboard seating position on the side of the test vehicle to be struck by the moving deformable barrier and, if the vehicle has a second seat, position another conforming test dummy in the second seat outboard position on the same side of the vehicle, as specified in S12.1.3. Each test dummy is restrained using all available belt systems in all seating positions where such belt restraints are provided. Adjustable belt anchorages are placed at the mid-adjustment position. In addition, any folding armrest is retracted. Additional positioning procedures are specified below.

S12.1.1 *Positioning a part 572, subpart F dummy in the driver position.*

(a) *Torso.* Hold the dummy's head in place and push laterally on the non-impacted side of the upper torso in a single stroke with a force of 66.7–89.0 N (15–20 lb) towards the impacted side.

(1) For a bench seat. The upper torso of the test dummy rests against the seat back. The midsagittal plane of the test dummy is vertical and parallel to the vehicle's longitudinal centerline, and passes through the center of the steering wheel.

(2) For a bucket seat. The upper torso of the test dummy rests against the seat back. The midsagittal plane of the test dummy is vertical and parallel to the vehicle's longitudinal centerline, and coincides with the longitudinal centerline of the bucket seat.

(b) *Pelvis.*

(1) H-point. The H-points of each test dummy coincide within 12.7 mm ( $\frac{1}{2}$  inch) in the vertical dimension and 12.7 mm ( $\frac{1}{2}$  inch) in the horizontal dimension of a point that is located 6.4 mm ( $\frac{1}{4}$  inch) below the position of the H-point determined by using the equipment for the 50th percentile and procedures specified in SAE J826 (1980) (incorporated by reference; see 49 CFR 571.5), except that Table 1 of SAE J826 is not applicable. The length of the lower leg and thigh segments of the H-point machine are adjusted to 414 and 401 mm (16.3 and 15.8 inches), respectively.

(2) Pelvic angle. As determined using the pelvic angle gauge (GM drawing 78051-532 incorporated by reference in part 572, subpart E of this chapter) which is inserted into the H-point gauging hole of the dummy, the angle of the plane of the surface on the lumbar-pelvic adaptor on which the lumbar spine attaches is 23 to 25 degrees from the horizontal, sloping upward toward the front of the vehicle.

(3) *Legs.* The upper legs of each test dummy rest against the seat cushion to the extent permitted by placement of the feet. The left knee of the dummy is positioned such that the distance from the outer surface of the knee pivot bolt to the dummy's midsagittal plane is 152.4 mm (6.0 inches). To the extent practicable, the left leg of the test dummy is in a vertical longitudinal plane.

(4) *Feet.* The right foot of the test dummy rests on the undepressed accelerator with the heel resting as far forward as possible on the floorpan. The left foot is set perpendicular to the lower leg with the heel resting on the floorpan in the same lateral line as the right heel.

S12.1.2 *Positioning a part 572, subpart F dummy in the front outboard seating position.*

(a) *Torso.* Hold the dummy's head in place and push laterally on the non-impacted side of the upper torso in a single stroke with a force of 66.7-89.0 N (15-20 lb) towards the impacted side.

(1) For a bench seat. The upper torso of the test dummy rests against the seat back. The midsagittal plane of the test dummy is vertical and parallel to the vehicle's longitudinal centerline, and the same distance from the vehicle's longitudinal centerline as would be the midsagittal plane of a test dummy positioned in the driver position under S12.1.1(a)(1).

(2) For a bucket seat. The upper torso of the test dummy rests against the seat back. The midsagittal plane of the test dummy is vertical and parallel to the

vehicle's longitudinal centerline, and coincides with the longitudinal centerline of the bucket seat.

(b) *Pelvis.*

(1) H-point. The H-points of each test dummy coincide within 12.7 mm ( $\frac{1}{2}$  inch) in the vertical dimension and 12.7 mm ( $\frac{1}{2}$  inch) in the horizontal dimension of a point that is located 6.4 mm ( $\frac{1}{4}$  inch) below the position of the H-point determined by using the equipment for the 50th percentile and procedures specified in SAE J826 (1980) (incorporated by reference; see 49 CFR 571.5), except that Table 1 of SAE J826 is not applicable. The length of the lower leg and thigh segments of the H-point machine are adjusted to 414 and 409 mm (16.3 and 15.8 inches), respectively.

(2) Pelvic angle. As determined using the pelvic angle gauge (GM drawing 78051-532 incorporated by reference in part 572, subpart E of this chapter) which is inserted into the H-point gauging hole of the dummy, the angle of the plane of the surface on the lumbar-pelvic adaptor on which the lumbar spine attaches is 23 to 25 degrees from the horizontal, sloping upward toward the front of the vehicle.

(c) *Legs.* The upper legs of each test dummy rest against the seat cushion to the extent permitted by placement of the feet. The initial distance between the outboard knee clevis flange surfaces is 292 mm (11.5 inches). To the extent practicable, both legs of the test dummies in outboard passenger positions are in vertical longitudinal planes. Final adjustment to accommodate placement of feet in accordance with S12.1.2(d) for various passenger compartment configurations is permitted.

(d) *Feet.* The feet of the test dummy are placed on the vehicle's toeboard with the heels resting on the floorpan as close as possible to the intersection of the toeboard and floorpan. If the feet cannot be placed flat on the toeboard, they are set perpendicular to the lower legs and placed as far forward as possible so that the heels rest on the floorpan.

S12.1.3 *Positioning a part 572, subpart F dummy in the rear outboard seating positions.*

(a) *Torso.* Hold the dummy's head in place and push laterally on the non-impacted side of the upper torso in a single stroke with a force of 66.7-89.0 N (15-20 lb) towards the impacted side.

(1) For a bench seat. The upper torso of the test dummy rests against the seat back. The midsagittal plane of the test dummy is vertical and parallel to the vehicle's longitudinal centerline, and, if possible, the same distance from the

vehicle's longitudinal centerline as the midsagittal plane of a test dummy positioned in the driver position under S12.1.1(a)(1). If it is not possible to position the test dummy so that its midsagittal plane is parallel to the vehicle longitudinal centerline and is at this distance from the vehicle's longitudinal centerline, the test dummy is positioned so that some portion of the test dummy just touches, at or above the seat level, the side surface of the vehicle, such as the upper quarter panel, an armrest, or any interior trim (*i.e.*, either the broad trim panel surface or a smaller, localized trim feature).

(2) For a bucket or contoured seat. The upper torso of the test dummy rests against the seat back. The midsagittal plane of the test dummy is vertical and parallel to the vehicle's longitudinal centerline, and coincides with the longitudinal centerline of the bucket or contoured seat.

(b) *Pelvis.*

(1) H-point. The H-points of each test dummy coincide within 12.7 mm ( $\frac{1}{2}$  inch) in the vertical dimension and 12.7 mm ( $\frac{1}{2}$  inch) in the horizontal dimension of a point that is located 6.4 mm ( $\frac{1}{4}$  inch) below the position of the H-point determined by using the equipment for the 50th percentile and procedures specified in SAE J826 (1980) (incorporated by reference; see 49 CFR 571.5), except that Table 1 of SAE J826 is not applicable. The length of the lower leg and thigh segments of the H-point machine are adjusted to 414 and 401 mm (16.3 and 15.8 inches), respectively.

(2) Pelvic angle. As determined using the pelvic angle gauge (GM drawing 78051-532 incorporated by reference in part 572, subpart E of this chapter) which is inserted into the H-point gauging hole of the dummy, the angle of the plane of the surface on the lumbar-pelvic adaptor on which the lumbar spine attaches is 23 to 25 degrees from the horizontal, sloping upward toward the front of the vehicle.

(c) *Legs.* Rest the upper legs of each test dummy against the seat cushion to the extent permitted by placement of the feet. The initial distance between the outboard knee clevis flange surfaces is 292 mm (11.5 inches). To the extent practicable, both legs of the test dummies in outboard passenger positions are in vertical longitudinal planes. Final adjustment to accommodate placement of feet in accordance with S12.1.3(d) for various passenger compartment configurations is permitted.

(d) *Feet.* Place the feet of the test dummy flat on the floorpan and beneath the front seat as far as possible without



front seat interference. If necessary, the distance between the knees may be changed in order to place the feet beneath the seat.

**S12.2 50th percentile male test dummy—49 CFR part 572, subpart [to be determined] (ES 2re).**

**S12.2.1 Positioning an ES-2re dummy in all seating positions.** Position a correctly configured ES-2re test dummy, conforming to the applicable requirements of part 572 of this chapter, in the front outboard seating position on the side of the test vehicle to be struck by the moving deformable barrier or pole and, for the moving deformable barrier test, if the vehicle has a second seat, position another conforming test dummy in the second seat outboard position on the same side of the vehicle. Restrain each test dummy using all available belt systems in all seating positions where such belt restraints are provided. Place adjustable belt anchorages at the mid-adjustment position. Retract any folding armrest.

(a) *Upper torso.*

(1) The plane of symmetry of the dummy coincides with the vertical median plane of the specified seating position.

(2) Bend the upper torso forward and then lay it back against the seat back. Set the shoulders of the dummy fully rearward.

(b) *Pelvis.* Position the pelvis of the dummy according to the following:

(1) Position the pelvis of the dummy such that a lateral line passing through the dummy H-points is perpendicular to the longitudinal center plane of the seat. The line through the dummy H-points is horizontal with a maximum inclination of  $\pm 2$  degrees. The dummy may be equipped with tilt sensors in the thorax and the pelvis. These instruments can help to obtain the desired position.

(2) The correct position of the dummy pelvis may be checked relative to the H-point of the H-point Manikin by using the M3 holes in the H-point back plates at each side of the ES-2re pelvis. The M3 holes are indicated with "Hm". The "Hm" position should be in a circle with a radius of 10 mm (0.39 inches) round the H-point of the H-point Manikin.

(c) *Arms.* For the driver seating position, place the dummy's upper arms such that the angle between the projection of the arm centerline on the mid-sagittal plane of the dummy and the torso reference line is  $40^\circ \pm 5^\circ$ . The torso reference line is defined as the thoracic spine centerline. The shoulder-arm joint allows for discrete arm positions at 0, 40, and 90 degree settings forward of the spine. For other seating

positions, place the upper arms at the  $0^\circ \pm 5^\circ$  setting in the shoulder-arm joint.

(d) *Legs and Feet.* Position the legs and feet of the dummy according to the following:

(1) For the driver's seating position, without inducing pelvis or torso movement, place the right foot of the dummy on the un-pressed accelerator pedal with the heel resting as far forward as possible on the floor pan. Set the left foot perpendicular to the lower leg with the heel resting on the floor pan in the same lateral line as the right heel. Set the knees of the dummy such that their outside surfaces are  $150 \pm 10$  mm ( $5.9 \pm 0.4$  inches) from the plane of symmetry of the dummy. If possible within these constraints, place the thighs of the dummy in contact with the seat cushion.

(2) For other seating positions, without inducing pelvis or torso movement, place the heels of the dummy as far forward as possible on the floor pan without compressing the seat cushion more than the compression due to the weight of the leg. Set the knees of the dummy such that their outside surfaces are  $150 \pm 10$  mm ( $5.9 \pm 0.4$  inches) from the plane of symmetry of the dummy.

**S12.3 5th percentile female test dummy—49 CFR part 572, subpart [to be determined] (SID IIsFRG).** Position a correctly configured 5th percentile female part 572 subpart [to be determined] (SID IIsFRG) test dummy, conforming to the applicable requirements of part 572 of this chapter, in the front outboard seating position on the side of the test vehicle to be struck by the moving deformable barrier or pole and, for the moving deformable barrier, if the vehicle has a second seat, position another conforming test dummy in the second seat outboard position on the same side of the vehicle as specified in S12.3.4. Retract any folding armrest. Additional procedures are specified below.

**S12.3.1 General provisions and definitions.**

(a) Measure all angles with respect to the horizontal plane unless otherwise stated.

(b) Adjust the SID-IIsFRG dummy's neck bracket to align the zero degree index marks.

(c) Other seat adjustments. The longitudinal centerline of a bucket seat cushion passes through the SgRP and is parallel to the longitudinal centerline of the vehicle.

(d) *Driver and passenger manual belt adjustment.* Use all available belt systems. Place adjustable belt anchorages at the nominal position for

a 5th percentile adult female suggested by the vehicle manufacturer.

(e) *Definitions.*

(1) The term "midsagittal plane" refers to the vertical plane that separates the dummy into equal left and right halves.

(2) The term "vertical longitudinal plane" refers to a vertical plane parallel to the vehicle's longitudinal centerline.

(3) The term "vertical plane" refers to a vertical plane, not necessarily parallel to the vehicle's longitudinal centerline.

(4) The term "transverse instrumentation platform" refers to the transverse instrumentation surface inside the dummy's skull casting to which the neck load cell mounts. This surface is perpendicular to the skull cap's machined inferior-superior mounting surface.

(5) The term "thigh" refers to the femur between, but not including, the knee and the pelvis.

(6) The term "leg" refers to the lower part of the entire leg including the knee.

(7) The term "foot" refers to the foot, including the ankle.

(8) For leg and thigh angles, use the following references:

(i) Thigh—a straight line on the thigh skin between the center of the  $\frac{1}{2}$ -13 UNC-2B tapped hole in the upper leg femur clamp and the knee pivot shoulder bolt.

(ii) Leg—a straight line on the leg skin between the center of the ankle shell and the knee pivot shoulder bolt.

(9) The term "seat cushion reference point" (SCRCP) means a point placed on the outboard side of the seat cushion at a horizontal distance between 150 mm (5.9 in) and 250 mm (9.8 in) from the front edge of the seat used as a guide in positioning the seat.

(10) The term "seat cushion reference line" means a line on the side of the seat cushion, passing through the seat cushion reference point, whose projection in the vehicle vertical longitudinal plane is straight and has a known angle with respect to the horizontal.

**S12.3.2 5th percentile female driver dummy positioning.**

(a) *Driver torso/head/seat back angle positioning.*

(1) With the seat in the position determined in S8.3.2, use only the control that moves the seat fore and aft to place the seat in the rearmost position. If the seat cushion reference line angle automatically changes as the seat is moved from the full forward position, maintain, as closely as possible, the seat cushion reference line angle determined in S8.3.2.3.3, for the final forward position when measuring the pelvic angle as specified in

S12.3.3(a)(11). The seat cushion reference angle position may be achieved through the use of any seat or seat cushion adjustments other than that which primarily moves the seat or seat cushion fore-aft.

(2) Fully recline the seat back, if adjustable. Install the dummy into the driver's seat, such that when the legs are positioned 120 degrees to the thighs, the calves of the legs are not touching the seat cushion.

(3) Bucket seats. Center the dummy on the seat cushion so that its midsagittal plane is vertical and passes within  $\pm 10$  mm ( $\pm 0.4$  in) of the SgRP.

(4) Bench seats. Position the midsagittal plane of the dummy vertical and parallel to the vehicle's longitudinal centerline and aligned within  $\pm 10$  mm ( $\pm 0.4$  in) of the center of the steering wheel rim.

(5) Hold the dummy's thighs down and push rearward on the upper torso to maximize the dummy's pelvic angle.

(6) Place the legs at 120 degrees to the thighs. Set the initial transverse distance between the longitudinal centerlines at the front of the dummy's knees at 160 to 170 mm (6.3 to 6.7 in), with the thighs and legs of the dummy in vertical planes. Push rearward on the dummy's knees to force the pelvis into the seat so there is no gap between the pelvis and the seat back or until contact occurs between the back of the dummy's calves and the front of the seat cushion.

(7) Gently rock the upper torso relative to the lower torso laterally in a side to side motion three times through a  $\pm 5$  degree arc (approximately 51 mm (2 in) side to side).

(8) If needed, extend the legs slightly so that the feet are not in contact with the floor pan. Let the thighs rest on the seat cushion to the extent permitted by the foot movement. Keeping the leg and the thigh in a vertical plane, place the foot in the vertical longitudinal plane that passes through the centerline of the accelerator pedal. Rotate the left thigh outboard about the hip until the center of the knee is the same distance from the midsagittal plane of the dummy as the right knee  $\pm 5$  mm ( $\pm 0.2$  in). Using only the control that moves the seat fore and aft, attempt to return the seat to the full forward position. If either of the dummy's legs first contacts the steering wheel, then adjust the steering wheel, if adjustable, upward until contact with the steering wheel is avoided. If the steering wheel is not adjustable, separate the knees enough to avoid steering wheel contact. Proceed with moving the seat forward until either the leg contacts the vehicle interior or the seat reaches the full forward position. (The right foot may contact and depress

the accelerator and/or change the angle of the foot with respect to the leg during seat movement.) If necessary to avoid contact with the vehicle's brake or clutch pedal, rotate the test dummy's left foot about the leg. If there is still interference, rotate the left thigh outboard about the hip the minimum distance necessary to avoid pedal interference. If a dummy leg contacts the vehicle interior before the full forward position is attained, position the seat at the next detent where there is no contact. If the seat is a power seat, move the seat fore and aft to avoid contact while assuring that there is a maximum of 5 mm (0.2 in) distance between the vehicle interior and the point on the dummy that would first contact the vehicle interior. If the steering wheel was moved, return it to the position described in S10.5. If the steering wheel contacts the dummy's leg(s) prior to attaining this position, adjust it to the next higher detent, or if infinitely adjustable, until there is 5 mm (0.2 in) clearance between the wheel and the dummy's leg(s).

(9) For vehicles without adjustable seat backs, adjust the lower neck bracket to level the head as much as possible. For vehicles with adjustable seat backs, while holding the thighs in place, rotate the seat back forward until the transverse instrumentation platform of the head is level to within  $\pm 0.5$  degree, making sure that the pelvis does not interfere with the seat bight. Inspect the abdomen to ensure that it is properly installed. If the torso contacts the steering wheel, adjust the steering wheel in the following order until there is no contact: telescoping adjustment, lowering adjustment, raising adjustment. If the vehicle has no adjustments or contact with the steering wheel cannot be eliminated by adjustment, position the seat at the next detent where there is no contact with the steering wheel as adjusted in S10.5. If the seat is a power seat, position the seat to avoid contact while assuring that there is a maximum of 5 mm (0.2 in) distance between the steering wheel as adjusted in S10.5 and the point of contact on the dummy.

(10) If it is not possible to achieve the head level within  $\pm 0.5$  degrees, minimize the angle.

(11) Measure and set the dummy's pelvic angle using the pelvic angle gage. The angle shall be set to 20.0 degrees  $\pm 2.5$  degrees. If this is not possible, adjust the pelvic angle as close to 20.0 degrees as possible while keeping the transverse instrumentation platform of the head as level as possible by adjustments specified in S12.3.2(a)(9) and (10).

(12) If the dummy is contacting the vehicle interior after these adjustments, move the seat rearward until there is a maximum of 5 mm (0.2 in) between the contact point of the dummy and the interior of the vehicle or if it has a manual seat adjustment, to the next rearward detent position. If after these adjustments, the dummy contact point is more than 5 mm (0.2 in) from the vehicle interior and the seat is still not in its forwardmost position, move the seat forward until the contact point is 5 mm (0.2 in) or less from the vehicle interior, or if it has a manual seat adjustment, move the seat to the closest detent position without making contact, or until the seat reaches its forwardmost position, whichever occurs first.

*(b) Driver foot positioning.*

(1) If the vehicle has an adjustable accelerator pedal, adjust it to the full forward position. If the heel of the right foot can contact the floor pan, follow the positioning procedure in S12.3.2(b)(1)(i). If not, follow the positioning procedure in S12.3.2(b)(1)(ii).

(i) Rest the right foot of the test dummy on the un-depressed accelerator pedal with the rearmost point of the heel on the floor pan in the plane of the pedal. If the foot cannot be placed on the accelerator pedal, set it initially perpendicular to the leg and then place it as far forward as possible in the direction of the pedal centerline with the rearmost point of the heel resting on the floor pan. If the vehicle has an adjustable accelerator pedal and the right foot is not touching the accelerator pedal when positioned as above, move the pedal rearward until it touches the right foot. If the accelerator pedal in the full rearward position still does not touch the foot, leave the pedal in that position.

(ii) Extend the foot and lower leg by decreasing the knee flexion angle until any part of the foot contacts the un-depressed accelerator pedal or the highest part of the foot is at the same height as the highest part of the pedal. If the vehicle has an adjustable accelerator pedal and the right foot is not touching the accelerator pedal when positioned as above, move the pedal rearward until it touches the right foot.

(2) If the ball of the foot does not contact the pedal, increase the ankle plantar flexion angle such that the toe of the foot contacts or is as close as possible to contact with the un-depressed accelerator pedal.

(3) If, in its final position, the heel is off of the vehicle floor, a spacer block must be used under the heel to support the final foot position. The surface of the block in contact with the heel has

an inclination of 30 degrees, measured from the horizontal, with the highest surface towards the rear of the vehicle.

(4) Place the left foot on the toe-board with the rearmost point of the heel resting on the floor pan as close as possible to the point of intersection of the planes described by the toe-board and floor pan, and not on or in contact with the vehicle's brake pedal, clutch pedal, wheel-well projection or foot rest, except as provided in S12.3.2(b)(6).

(5) If the left foot cannot be positioned on the toe board, place the foot perpendicular to the lower leg centerline as far forward as possible with the heel resting on the floor pan.

(6) If the left foot does not contact the floor pan, place the foot parallel to the floor and place the leg perpendicular to the thigh as possible. If necessary to avoid contact with the vehicle's brake pedal, clutch pedal, wheel-well, or foot rest, use the three foot position adjustments listed in S12.3.2(b)(1)(i)-(iii). The adjustment options are listed in priority order, with each subsequent option incorporating the previous. In making each adjustment, move the foot the minimum distance necessary to avoid contact. If it is not possible to avoid all prohibited foot contact, priority is given to avoiding brake or clutch pedal contact:

(i) Rotate (abduction/adduction) the test dummy's left foot about the lower leg;

(ii) Planar flex the foot;

(iii) Rotate the left leg outboard about the hip.

(c) *Driver arm/hand positioning.*

(1) Place the dummy's upper arm such that the angle between the projection of the arm centerline on the midsagittal plane of the dummy and the torso reference line is  $40^\circ \pm 5^\circ$ . The torso reference line is defined as the thoracic spine centerline. The shoulder-arm joint allows for discrete arm positions at  $0^\circ$ ,  $\pm 40^\circ$ ,  $\pm 90^\circ$ ,  $\pm 140^\circ$ , and  $180^\circ$  degree settings where positive is forward of the spine.

(2) [Reserved]

S12.3.3 *5th percentile female front passenger dummy positioning.*

(a) *Passenger torso/head/seat back angle positioning.*

(1) With the seat at the mid-height in the full-forward position determined in S8.3.2, use only the control that primarily moves the seat fore and aft to place the seat in the rearmost position, without adjusting independent height controls. If the seat cushion reference angle automatically changes as the seat is moved from the full forward position, maintain, as closely as possible, the seat cushion reference line angle determined in S8.3.2.3.3, for the final forward position when measuring the pelvic

angle as specified in S12.3.3(a)(11). The seat cushion reference line angle position may be achieved through the use of any seat or seat cushion adjustments other than that which primarily moves the seat or seat cushion fore-aft.

(2) Fully recline the seat back, if adjustable. Place the dummy into the passenger's seat, such that when the legs are positioned 120 degrees to the thighs, the calves of the legs are not touching the seat cushion.

(3) Bucket seats. Place the dummy on the seat cushion so that its midsagittal plane is vertical and passes through the SgRP within + 10 mm ( $\pm 0.4$  in).

(4) Bench seats. Position the midsagittal plane of the dummy vertical and parallel to the vehicle's longitudinal centerline and the same distance from the vehicle's longitudinal centerline, within + 10 mm ( $\pm 0.4$  in), as the midsagittal plane of the driver dummy.

(5) Hold the dummy's thighs down and push rearward on the upper torso to maximize the dummy's pelvic angle.

(6) Place the legs at 120 degrees to the thighs. Set the initial transverse distance between the longitudinal centerlines at the front of the dummy's knees at 160 to 170 mm (6.3 to 6.7 in), with the thighs and legs of the dummy in vertical planes. Push rearward on the dummy's knees to force the pelvis into the seat so there is no gap between the pelvis and the seat back or until contact occurs between the back of the dummy's calves and the front of the seat cushion.

(7) Gently rock the upper torso relative to the lower torso laterally in a side to side motion three times through a  $\pm 5$  degree arc (approximately 51 mm (2 in) side to side).

(8) If needed, extend the legs slightly so that the feet are not in contact with the floor pan. Let the thighs rest on the seat cushion to the extent permitted by the foot movement. With the feet perpendicular to the legs, place the heels on the floor pan. If a heel will not contact the floor pan, place it as close to the floor pan as possible. Using only the control that primarily moves the seat fore and aft, attempt to return the seat to the full forward position. If a dummy leg contacts the vehicle interior before the full forward position is attained, position the seat at the next detent where there is no contact. If the seats are power seats, position the seat to avoid contact while assuring that there is a maximum of 5 mm (0.2 in) distance between the vehicle interior and the point on the dummy that would first contact the vehicle interior.

(9) For vehicles without adjustable seat backs, adjust the lower neck bracket to level the head as much as possible.

For vehicles with adjustable seat backs, while holding the thighs in place, rotate the seat back forward until the transverse instrumentation platform of the head is level to within  $\pm 0.5$  degree, making sure that the pelvis does not interfere with the seat bight. Inspect the abdomen to ensure that it is properly installed.

(10) If it is not possible to achieve the head level within  $\pm 0.5$  degrees, minimize the angle.

(11) Measure and set the dummy's pelvic angle using the pelvic angle gage. The angle shall be set to 20.0 degrees  $\pm$  2.5 degrees. If this is not possible, adjust the pelvic angle as close to 20.0 degrees as possible while keeping the transverse instrumentation platform of the head as level as possible by adjustments specified in S12.3.3(a)(9) and (10).

(12) If the dummy is contacting the vehicle interior after these adjustments, move the seat rearward until there is a maximum of 5 mm (0.2 in) between the contact point of the dummy and the interior of the vehicle or if it has a manual seat adjustment, to the next rearward detent position. If after these adjustments, the dummy contact point is more than 5 mm (0.2 in) from the vehicle interior and the seat is still not in its forwardmost position, move the seat forward until the contact point is 5 mm (0.2 in) or less from the vehicle interior, or if it has a manual seat adjustment, move the seat to the closest detent position without making contact, or until the seat reaches its forwardmost position, whichever occurs first.

(b) *Passenger foot positioning.*

(1) Place the front passenger's feet flat on the toe board.

(2) If the feet cannot be placed flat on the toe board, set them perpendicular to the leg center lines and place them as far forward as possible with the heels resting on the floor pan.

(3) Place the rear seat passenger's feet flat on the floor pan and beneath the front seat as far as possible without front seat interference.

(c) *Passenger arm/hand positioning.*

Place the dummy's upper arm such that the angle between the projection of the arm centerline on the mid-sagittal plane of the dummy and the torso reference line is  $0^\circ \pm 5^\circ$ . The torso reference line is defined as the thoracic spine centerline. The shoulder-arm joint allows for discrete arm positions at  $0^\circ$ ,  $\pm 40^\circ$ ,  $\pm 90^\circ$ ,  $\pm 140^\circ$ , and  $180^\circ$  degree settings where positive is forward of the spine.

S12.3.4 *5th percentile female in rear outboard seating positions.*

(a) Set the seat at the full rearward, full down position determined in S8.3.3.

(b) Fully recline the seat back, if adjustable. Install the dummy into the passenger seat, such that when the legs are 120 degrees to the thighs, the calves of the legs are not touching the seat cushion.

(c) Place the dummy on the seat cushion so that its midsagittal plane is vertical and coincides with the vertical longitudinal plane through the center of the seating position SgRP within  $\pm 10$  mm ( $\pm 0.4$  mm).

(d) Hold the dummy's thighs down and push rearward on the upper torso to maximize the dummy's pelvic angle.

(e) Place the legs at 120 degrees to the thighs. Set the initial transverse distance between the longitudinal centerlines at the front of the dummy's knees at 160 to 170 mm (6.3 to 6.7 in), with the thighs and legs of the dummy in vertical planes. Push rearward on the dummy's knees to force the pelvis into the seat so there is no gap between the pelvis and the seat back or until contact occurs between the back of the dummy's calves and the front of the seat cushion.

(f) Gently rock the upper torso laterally side to side three times through a  $\pm 5$  degree arc (approximately 51 mm (2 in) side to side).

(g) If needed, extend the legs slightly so that the feet are not in contact with the floor pan. Let the thighs rest on the seat cushion to the extent permitted by the foot movement. With the feet perpendicular to the legs, place the heels on the floor pan. If a heel will not contact the floor pan, place it as close to the floor pan as possible.

(h) For vehicles without adjustable seat backs, adjust the lower neck bracket to level the head as much as possible. For vehicles with adjustable seat backs, while holding the thighs in place, rotate the seat back forward until the transverse instrumentation platform of the head is level to within  $\pm 0.5$  degrees, making sure that the pelvis does not interfere with the seat bight. Inspect the abdomen to insure that it is properly installed.

(i) If it is not possible to orient the head level within  $\pm 0.5$  degrees, minimize the angle.

(j) Measure and set the dummy's pelvic angle using the pelvic angle gauge. The angle shall be set to 20.0 degrees  $\pm 2.5$  degrees. If this is not possible, adjust the pelvic angle as close to 20.0 degrees as possible while keeping the transverse instrumentation platform of the head as level as possible, as specified in S12.3.4(h) and (i).

(k) Passenger foot positioning.

(1) Place the passenger's feet flat on the floor pan.

(2) If the either foot does not contact the floor pan, place the foot parallel to

the floor and place the leg as perpendicular to the thigh as possible

(l) *Passenger arm/hand positioning.* Place the dummy's upper arm such that the angle between the projection of the arm centerline on the midsagittal plane of the dummy and the torso reference line is  $0^\circ \pm 5^\circ$ . The torso reference line is defined as the thoracic spine centerline. The shoulder-arm joint allows for discrete arm positions at 0,  $\pm 40$ ,  $\pm 90$ ,  $\pm 140$ , and 180 degree settings where positive is forward of the spine.

S13 *Phase-in of vehicle-to-pole test and performance requirements for vehicles manufactured on or after September 1, 2009 and before September 1, 2011.*

S13.1 *Vehicles manufactured on or after September 1, 2009 and before September 1, 2011.* At anytime during the production years ending August 31 of each year, each manufacturer shall, upon request from the Office of Vehicle Safety Compliance, provide information identifying the vehicles (by make, model and vehicle identification number) that have been certified as complying with the vehicle-to-pole test requirements (S9.2) of this standard. The manufacturer's designation of a vehicle as a certified vehicle is irrevocable.

S13.1.1 *Vehicles manufactured on or after September 1, 2009 and before September 1, 2010.* Subject to S13.4, for vehicles manufactured on or after September 1, 2009 and before September 1, 2010, the number of vehicles complying with S9.2 shall be not less than 20 percent of:

(a) The manufacturer's average annual production of vehicles manufactured in the three previous production years; or

(b) The manufacturer's production in the current production year.

S13.1.2 *Vehicles manufactured on or after September 1, 2010 and before September 1, 2011.* Subject to S13.4, for vehicles manufactured on or after September 1, 2010 and before September 1, 2011, the number of vehicles complying with S9.2 shall be not less than 50 percent of:

(a) The manufacturer's average annual production of vehicles manufactured in the three previous production years; or

(b) The manufacturer's production in the current production year.

S13.2 *Vehicles produced by more than one manufacturer.*

S13.2.1 For the purpose of calculating average annual production of vehicles for each manufacturer and the number of vehicles manufactured by each manufacturer under S13.1.1 and S13.1.2, a vehicle produced by more than one manufacturer shall be

attributed to a single manufacturer as follows, subject to S13.2.2.

(a) A vehicle that is imported shall be attributed to the importer.

(b) A vehicle manufactured in the United States by more than one manufacturer, one of which also markets the vehicle, shall be attributed to the manufacturer that markets the vehicle.

S13.2.2 A vehicle produced by more than one manufacturer shall be attributed to any one of the vehicle's manufacturers specified by an express written contract, reported to the National Highway Traffic Safety Administration under 49 CFR part 598, between the manufacturer so specified and the manufacturer to which the vehicle would otherwise be attributed under S13.2.1.

S13.3 For the purposes of calculating average annual production of vehicles for each manufacturer and the number of vehicles manufactured by each manufacturer under S13.1.1 and S13.1.2, each vehicle that is excluded by S5(c) from the vehicle-to-pole test requirements is not counted.

S13.4 Calculation of complying vehicles.

(a) For the purposes of complying with S13.1.1, a manufacturer may count a vehicle if it is manufactured on or after [date that is 30 days after publication of a final rule], but before September 1, 2010.

(b) For purposes of complying with S13.1.2, a manufacturer may count a vehicle if it—

(1) Is manufactured on or after [date that is 30 days after publication of a final rule], but before September 1, 2011 and,

(2) Is not counted toward compliance with S13.1.1.

3. Part 598 would be added to read as follows:

#### **PART 598—SIDE IMPACT PHASE-IN REPORTING REQUIREMENTS**

Sec.

598.1 Scope.

598.2 Purpose.

598.3 Applicability.

598.4 Definitions.

598.5 Response to inquiries.

598.6 Reporting requirements.

598.7 Records.

598.8 Petition to extend period to file report.

**Authority:** 49 U.S.C. 322, 30111, 30115, 30117 and 30166; delegation of authority at 49 CFR 1.50.

#### **§ 598.1 Scope.**

This part establishes requirements for manufacturers of passenger cars, and of trucks, buses and multipurpose

passenger vehicles with a gross vehicle weight rating (GVWR) of 4,536 kilograms (kg) (10,000 pounds) or less, to submit a report, and maintain records related to the report, concerning the number of such vehicles that meet the vehicle-to-pole test requirements of S9 of Standard No. 214, *Side impact protection* (49 CFR 571.214).

#### § 598.2 Purpose.

The purpose of these reporting requirements is to assist the National Highway Traffic Safety Administration in determining whether a manufacturer has complied with the requirements of Standard No. 214, *Side Impact Protection* (49 CFR 571.214).

#### § 598.3 Applicability.

This part applies to manufacturers of passenger cars, and of trucks, buses and multipurpose passenger vehicles with a GVWR of 4,536 kg (10,000 lb) or less. However, this part does not apply to vehicles excluded by S2 and S5 of Standard No. 214 (49 CFR 571.214) from the requirements of that standard.

#### § 598.4 Definitions.

(a) All terms defined in 49 U.S.C. 30102 are used in their statutory meaning.

(b) Bus, gross vehicle weight rating or GVWR, multipurpose passenger vehicle, passenger car, and truck are used as defined in § 571.3 of this chapter.

(c) Production year means the 12-month period between September 1 of one year and August 31 of the following year, inclusive.

(d) Limited line manufacturer means a manufacturer that sells three or fewer carlines, as that term is defined in 49 CFR 583.4, in the United States during a production year.

#### § 598.5 Response to inquiries.

At anytime during the production years ending August 31, 2010, August 31, 2011, and August 31, 2012, each manufacturer shall, upon request from the Office of Vehicle Safety Compliance, provide information identifying the vehicles (by make, model and vehicle identification number) that have been certified as complying with the vehicle-to-pole test of FMVSS No. 214 (49 CFR 571.214).

#### § 598.6 Reporting requirements.

(a) *Advanced credit phase-in reporting requirements.* (1) Within 60 days after the end of the production years ending August 31, 2006, August 31, 2007, August 31, 2008, and August 31, 2009, each manufacturer choosing to certify vehicles manufactured during any of those production years as complying with the vehicle-to-pole

requirements of S9 of Standard No. 214 (49 CFR 571.214) shall submit a report to the National Highway Traffic Safety Administration as specified in paragraph (a)(2) of this section.

(2) Each report shall—

(i) Identify the manufacturer;

(ii) State the full name, title, and address of the official responsible for preparing the report;

(iii) Identify the production year being reported on;

(iv) Provide the information specified in paragraph (c) of this section;

(v) Be written in the English language; and

(vi) Be submitted to: Administrator, National Highway Traffic Safety Administration, 400 Seventh Street, SW., Washington, DC 20590.

(b) *Phase-in reporting requirements.* Within 60 days after the end of each of the production years ending August 31, 2010 and August 31, 2011, each manufacturer shall submit a report to the National Highway Traffic Safety Administration concerning its compliance with the vehicle-to-pole requirements of S9 of Standard No. 214 for its vehicles produced in that year. Each report shall—

(1) Identify the manufacturer;

(2) State the full name, title, and address of the official responsible for preparing the report;

(3) Identify the production year being reported on;

(4) Contain a statement regarding whether or not the manufacturer complied with the vehicle-to-pole requirements of S9 of Standard No. 214 for the period covered by the report and the basis for that statement;

(5) Provide the information specified in paragraph (d) of this section, except that this information need not be submitted with the report due 60 days after August 31, 2010 if the manufacturer chooses the compliance option specified in S9.1.3 of 49 CFR 571.214;

(6) Specify the number of advance credit vehicles, if any, that are being applied to the production year being reported on;

(7) Be written in the English language; and

(8) Be submitted to: Administrator, National Highway Traffic Safety Administration, 400 Seventh Street, SW., Washington, DC 20590.

(c) *Advanced credit phase-in report content—*(1) *Production of complying vehicles.* With respect to the reports identified in § 598.6(a), each manufacturer shall report for the production year for which the report is filed the number of vehicles, by make and model year, that are certified as

meeting the vehicle-to-pole requirements of S9 of Standard No. 214.

(2) *Vehicles produced by more than one manufacturer.* Each manufacturer whose reporting of information is affected by one or more of the express written contracts permitted by S13.2.2 of Standard No. 214 shall:

(i) Report the existence of each contract, including the names of all parties to the contract and explain how the contract affects the report being submitted.

(ii) Report the number of vehicles covered by each contract in each production year.

(d) *Phase-in report content—*(1) *Basis for phase-in production goals.* Each manufacturer shall provide the number of passenger cars manufactured for sale in the United States for each of the three previous production years, or, at the manufacturer's option, for the current production year. A new manufacturer that is, for the first time, manufacturing passenger cars for sale in the United States must report the number of passenger cars manufactured during the current production year.

(2) *Production of complying vehicles.* Each manufacturer shall report for the production year being reported on, and each preceding production year, to the extent that vehicles produced during the preceding years are treated under Standard No. 214 as having been produced during the production year being reported on, information on the number of passenger vehicles that meet the vehicle-to-pole performance requirements of Standard No. 214.

(3) *Vehicles produced by more than one manufacturer.* Each manufacturer whose reporting of information is affected by one or more of the express written contracts permitted by S13.2.2 of Standard No. 214 shall:

(i) Report the existence of each contract, including the names of all parties to the contract, and explain how the contract affects the report being submitted.

(ii) Report the actual number of vehicles covered by each contract.

#### § 598.7 Records.

Each manufacturer shall maintain records of the Vehicle Identification Number for each vehicle for which information is reported under § 598.6(c)(1) and § 598.6(d)(2) until December 31, 2011.

#### § 598.8 Petition to extend period to file report.

A petition for extension of the time to submit a report must be received not later than 15 days before expiration of the time stated in § 598.6. The petition

must be submitted to: Administrator,  
National Highway Traffic Safety  
Administration, 400 Seventh Street,  
SW., Washington, DC 20590. The filing  
of a petition does not automatically

extend the time for filing a report. A  
petition will be granted only if the  
petitioner shows good cause for the  
extension and if the extension is  
consistent with the public interest.

Issued on May 10, 2004.

**Stephen R. Kratzke,**

*Associate Administrator for Rulemaking.*

[FR Doc. 04-10931 Filed 5-12-04; 1:30 pm]

**BILLING CODE 4910-59-P**