

Analysis of the collision direction based on Traffic accident data (2005 Japan)

SGS 6 - 21

Causalities (n = 2,712)

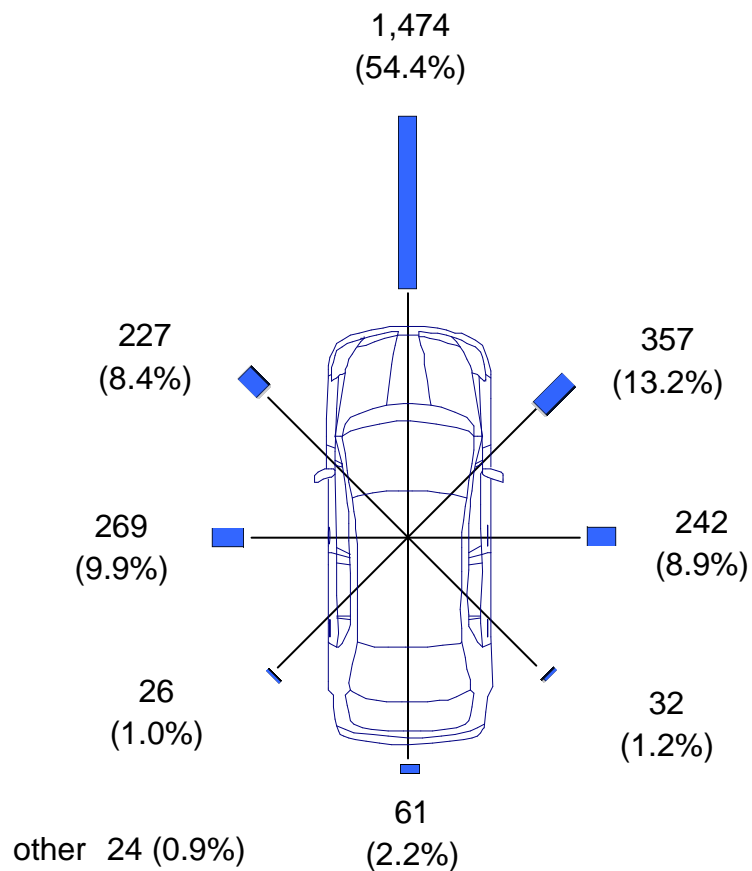

The wounded (n= 701,981)

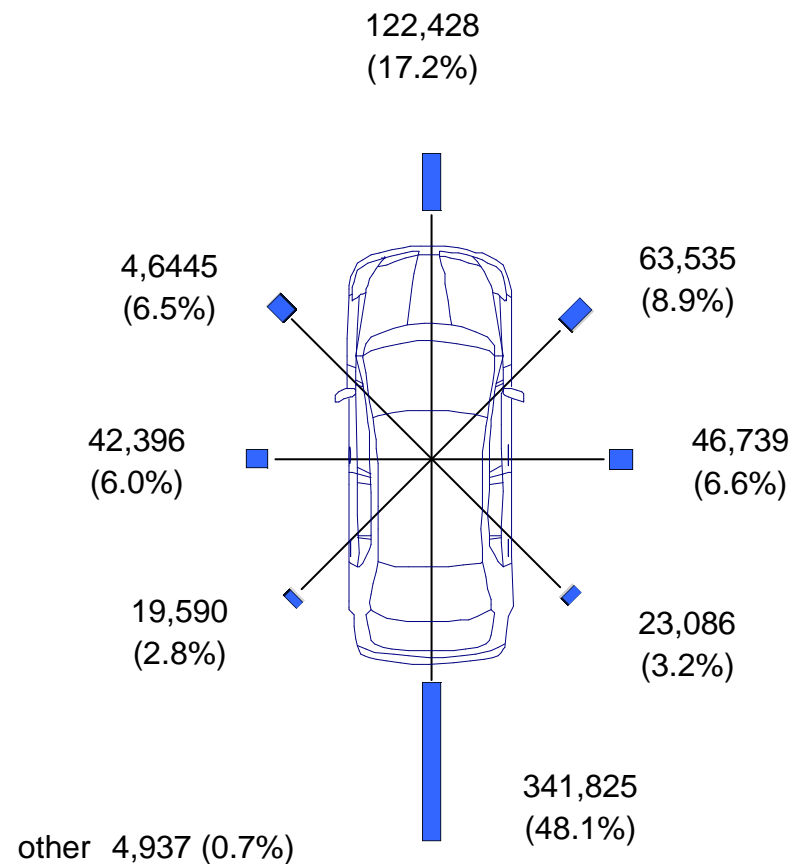

A collision direction in the crash test prescribed by Japanese law is as the following.

In case of occupant protection : 3 direction of front, offset and side (○)

In case of fuel leakage : 3 direction of front, back and side(□)

The aim of crash tests is mainly for occupant protection.

Therefore, there are subjects to be considered for fuel leakage evaluation, such as, inconsistency of the collision point of the side and the location of the fuel pipe, no crash test from the oblique back to the neighborhood of the fuel container, etc.

