



Working paper No. GRPE-PMP-19-5  
19th PMP working meeting  
*Geneva, 6 June 2007*

*Progress in the HD Inter-laboratory Comparison Exercise*

*Barouch Giechaskiel*  
*Massimo Carriero*  
*Giorgio Martini*



# Exploratory Work, Validation, Round Robin

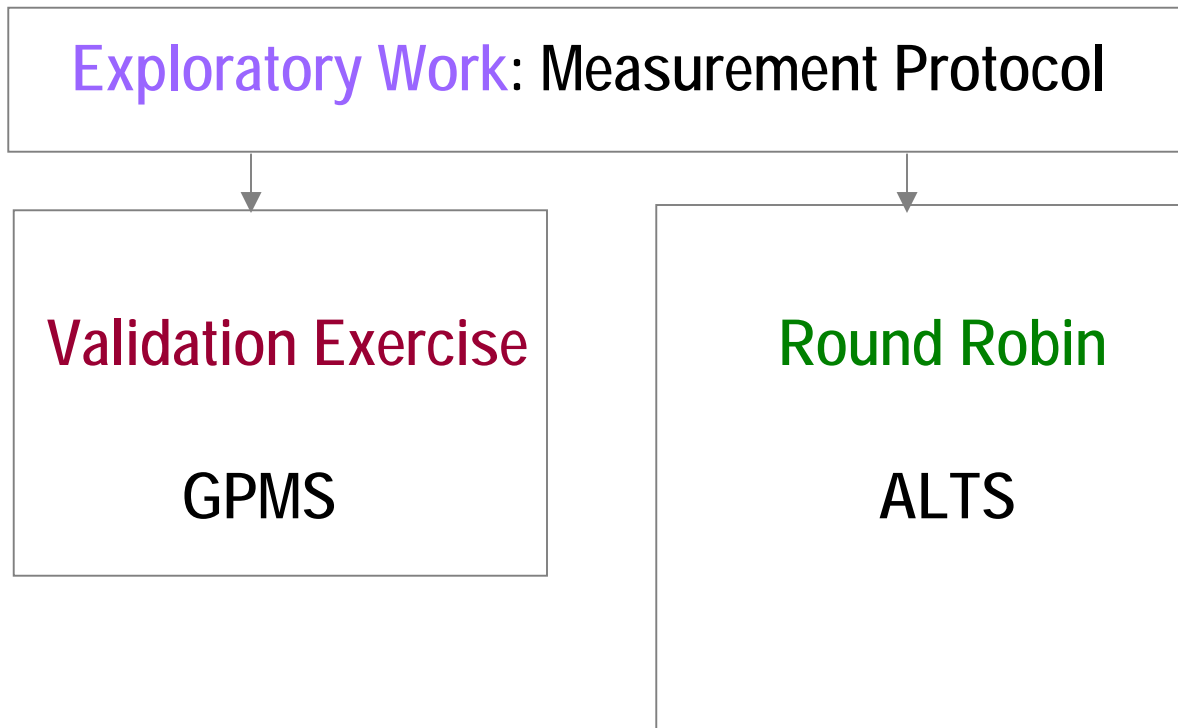



# Exploratory Work in JRC

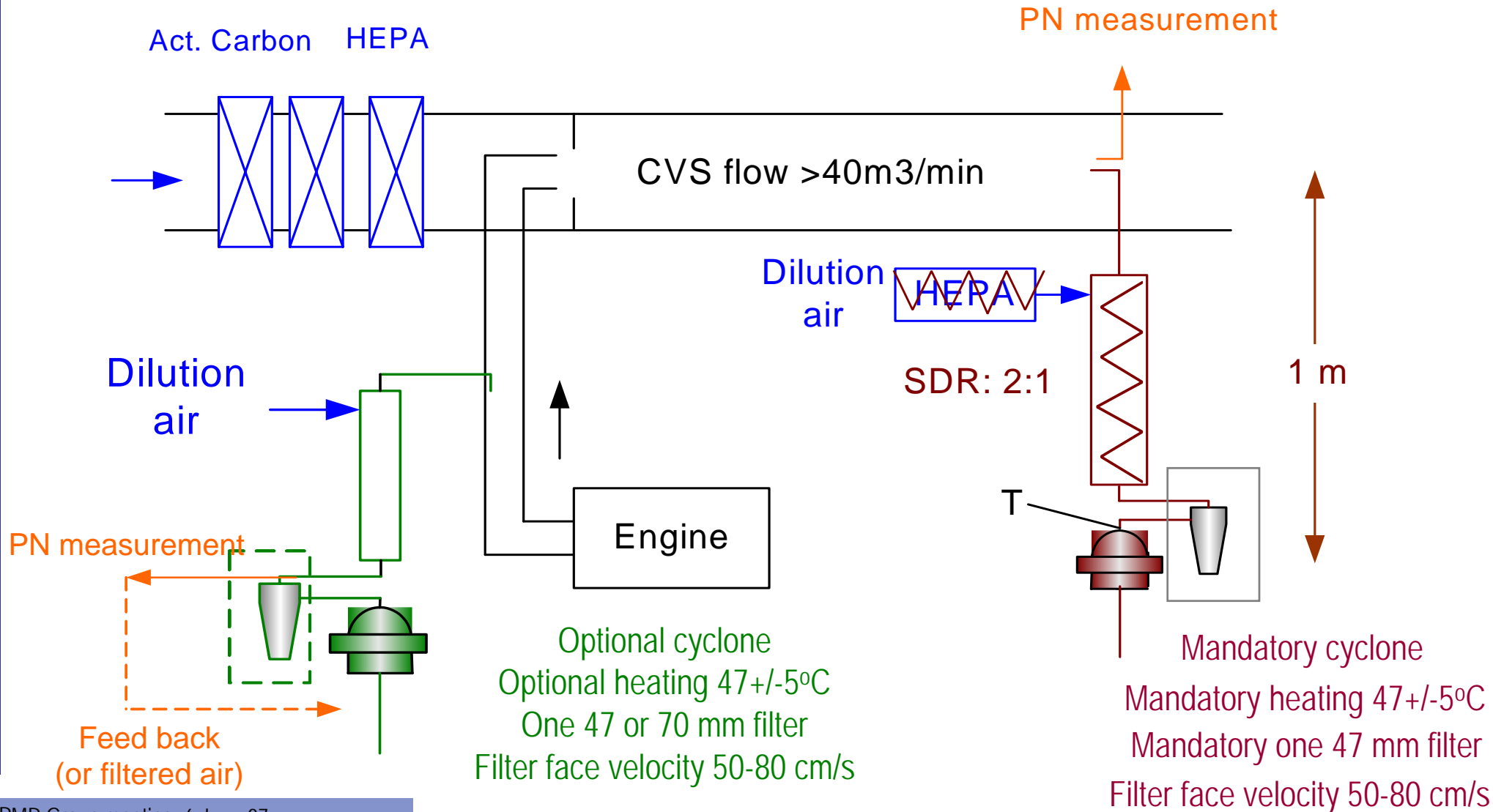



## Exploratory Work in JRC

- Protocol
- Full dilution tunnel
  - CVS flowrates (Primary-secondary tunnel)
  - Cyclone, heating, filter material
- Partial flow system
  - Sampling position for the partial flow system
  - Control Sistem, AVL smart sampler
- Particle Number Systems
  - SPCS, MD19, Ejector



# PMP Heavy Duty **Validation Exercise** and **Round Robin**

## PMP HD Validation Exercise

- Golden Engine-1
- Golden Systems
- Golden Engineer
- Same fuel and lubricant
- Both full flow system and partial flow system
- European Laboratories only

## PMP HD Round Robin exercise

- Golden Engine-2
- Instrument chosen by each lab
- No Golden Engineer
- Standard ref. fuel
- Only full flow system
- Non-European Laboratories as well



# PMP HD Validation Exercise

## Current status

- Programme behind the schedule
- Delays mainly due to technical and administrative reasons
  - Very long administrative procedure (hiring of golden instruments, procurement procedures,...)
  - Delay of the test cell upgrade due to technical problems



# PMP HD Validation Exercise

## Current status

- Upgrade of engine test cell
  - Software (WHTC): completed.
    - Checking of the correct functioning of the system
  - Hardware : almost completed
    - Full flow dilution system
    - Partial flow dilution system
- Golden engine ready to be installed



# PMP HD Validation Exercise

## Current status

- Golden system
  - Horiba system selected: two SPCS will be hired
  - Administrative procedure (very long lasting) on going
  - Offer received
  
- Fuel & lubricant
  - Procurement procedures taking much more time than expected
    - Total (fuel)
    - BP (lubricant) – registration procedure
  
- Expected start:
  - 2<sup>nd</sup> half of June



# PMP HD Validation Exercise

## Laboratories

- 4 Labs confirmed
- 1-2 more Labs are expected to join (waiting for the final confirmation)

	Laboratory	Possible Time slot
1	DG-JRC	July-August 2007
2	UTAC	September-October 2007
3	AVL-MTC	November-December 2007
4	EMPA	tbd
5		tbd
6	DG-JRC	tbd



# PMP HD Round Robin Exercise Laboratories

- 6 European Laboratories
- 4 Non-European Laboratories

	Laboratory	Possible Time slot
1	DG-JRC, EC	tbd
2	TÜV Nord Mobilität – Germany	August 2007
3	Volvo Powertrain, Sweden	Next to TÜV
4	NTSEL, Japan	Early 2008
5	JARI, Japan	Next to NTSEL
6	NIER, Korea	Next to JARI
7	VTT, Finland	tbd
8	UTAC, France	tbc
9	SCANIA, Sweden	tbd
10	Environment Canada	tbd



# Thank you for your attention!

For further details or questions, please contact

The PMP Interlab Manager:

Giorgio Martini

*JRC, TP 441,*

*Ispra, (VA) 21020, Italy*

*Tel: +39-0332-789293*

*Fax: +39-0332-785869*

*E-mail: [giorgio.martini@jrc.it](mailto:giorgio.martini@jrc.it)*