

PROPOSAL FOR DRAFT AMENDMENTS TO REGULATION No. 52
(Proposed by the Spanish delegation)

Paragraph 5.6.2.5.2., amend to read

"5.6.2.5.2. The driver's door shall be accepted as the emergency door for the occupants of the seats situated beside the driver's seat **provided that it is possible to move a test gauge from the occupants' seats to the exterior of the vehicle through the driver's door (see annex 3, figure 20).**

Verification of the access to the driver's door shall be subject to the requirements of paragraph 5.7.3.2., by using the test gauge having a dimension of 600x400 mm, as described in paragraph 5.7.3.3. The service door provided for the passengers shall be in the side of the vehicle opposite to that containing the driver's door and shall be accepted as the emergency door for the driver;"

Footnote 5 of paragraph 5.6.2.5.2., should be deleted.

Paragraph 5.7.2.4.2, amend to read

" defined in paragraph 5.6.2.5.2. and that the space reserved to the driver's seat shall communicate with the main passengers' compartment through an appropriate passage; such requirement shall be deemed to be fulfilled if the test gauge described in paragraph 5.7.5.1. can move unobstructed from the gangway, enabling that the front end of the gauge reaches the vertical plane tangential to the foremost point of the driver's seat back (situated this seat in its rearmost possible position) and, from this plane, the panel described in paragraph 5.6.2.5.2. could be moved to the emergency door in the direction established by such paragraph (see annex 3, figure 21)."

Annex 3, insert news figures:

Figure 20

Access to driver's door
(See paragraph 5.6.2.5.2.)

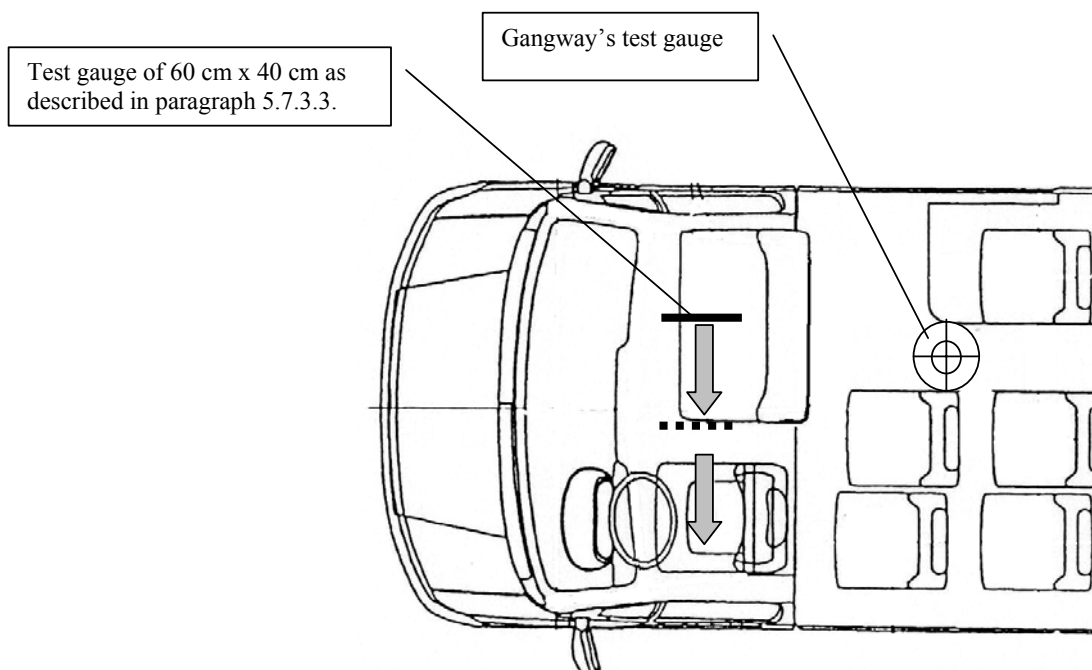
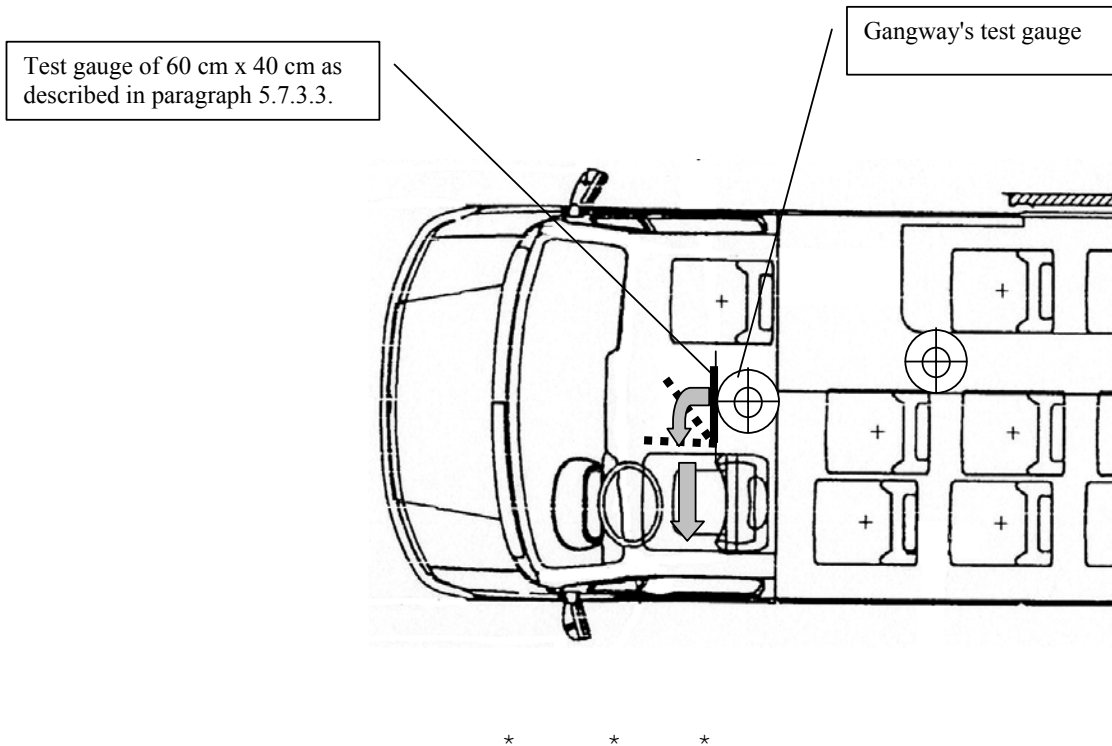

Figure 21
Access to driver's door
(See paragraph 5.7.2.4.2.)



JUSTIFICATION

This proposal for amendment pretends to establish an objective method of verifying the conditions specified in paragraph 5.6.2.5.2. and that the driver's post and the accesses to the driver's seat fulfil all the requirements to allow that the driver's door could be considered as the emergency door for the main passengers' compartment.

The main purpose of this proposal is to require the same safety conditions for the passengers when they pass through the driver's seat as those when they have to use an emergency window - passing through the passengers' seats.