



**Economic and Social  
Council**

Distr.  
GENERAL

TRANS/WP.29/GRB/2002/4/Rev.1  
18 July 2003

ENGLISH  
Original: ENGLISH  
ENGLISH AND FRENCH ONLY

---

**ECONOMIC COMMISSION FOR EUROPE**

INLAND TRANSPORT COMMITTEE

World Forum for Harmonization of Vehicle Regulations (WP.29)

Working Party on Noise (GRB)

(Thirty-eighth session, 9 and 10 October 2003,  
agenda item 1.1.)

PROPOSAL FOR DRAFT AMENDMENTS TO REGULATION No. 51  
(03 series of amendments)

(Sound emissions of M and N categories of vehicles)

Transmitted by the experts from Germany and the  
International Organization for Standardization (ISO)

(Revised by the GRB Informal Group)

Note: The text reproduced below was prepared by the experts from Germany and ISO, in order to improve the vehicle test methods for measuring the sound level. Minor (editorial) changes have been approved by the GRB Informal Group. Items to be considered by the GRB experts or changes of importance are marked in **bold** character.

---

Note: This document is distributed to the Experts on Noise only.

Regulation No. 51

UNIFORM PROVISIONS CONCERNING THE APPROVAL OF MOTOR VEHICLES  
HAVING AT LEAST FOUR WHEELS WITH REGARD TO THEIR SOUND EMISSIONS  
(Vehicles of categories M and N)

CONTENTS

		<u>Page:</u>
1.	Scope .....	3
2.	Definitions .....	3
3.	Application for approval .....	4
4.	Markings.....	5
5.	Approval.....	5
6.	Specifications .....	7
7.	Modification and extension of approval of a vehicle type .....	9
8.	Conformity of production.....	10
9.	Penalties for non-conformity of production .....	10
10.	Production definitely discontinued.....	10
11.	Transitional provisions .....	10
12.	Names and addresses of technical services responsible for conducting approval tests, and of administrative departments .....	11

ANNEXES

- Annex 1 - Communication concerning the approval or extension or refusal or withdrawal of approval or production definitely discontinued of a vehicle type with regard to its sound emission pursuant to Regulation No. 51
- Annex 2 - Arrangements of the approval mark
- Annex 3 - Methods and instruments for measuring the sound made by motor vehicles
- Annex 4 - Classification of vehicles
- Annex 5 - Exhaust systems containing fibrous materials
- Annex 6 - Compressed air sound
- Annex 7 - Checks on conformity of production
- Annex 8 - Specifications for the test site
- Annex 9 - Symbols used
- Annex 10 - Additional sound emission provisions
- Annex 11 - Example for measurement procedure for vehicles of category M<sub>1</sub>, N<sub>1</sub>
-

1. SCOPE

This Regulation contains provisions relating to the sound emitted by motor vehicles of categories M and N.

The specifications in this Regulation are intended to reproduce the sound levels which are generated by vehicles during normal driving in urban traffic.

2. DEFINITIONS

For the purpose of this Regulation,

- 2.1. "Approval of a vehicle" means the approval of a vehicle type with regard to sound;
- 2.2. "Vehicle type" means motor vehicles which do not differ essentially in such respects as:
- 2.2.1. the shape or materials of the bodywork (particularly the engine compartment and its soundproofing);
- 2.2.2. the length and width of the vehicle;
- 2.2.3. the type of engine (positive or compression ignition, two- or four-stroke, reciprocating or rotary piston), number and capacity of cylinders, number and type of carburettors or injection system, arrangement of valves, rated maximum power and corresponding engine speed(s), or the type of electric motor;
- 2.2.4. the transmission system, the number of gears and ratios;
- 2.2.5. the sound reduction system as defined in the following paragraphs 2.3. and 2.4.
- 2.2.6. Notwithstanding the provisions of paragraphs 2.2.2. and 2.2.4., vehicles other than those in categories M<sub>1</sub> and N<sub>1</sub> <sup>1/</sup> having the same type of engine and/or different overall gear ratios, may be regarded as vehicles of the same type.

However, if the above differences provide for a different test method, these differences are to be considered as a change of type.

- 2.3. "Sound reduction system" means a complete set of components necessary for limiting the sound made by a motor vehicle;
- 2.4. "Sound reduction systems of different types" means sound reduction systems which differ in such essential respects as:

---

<sup>1/</sup> In conformity with the definitions given in the Consolidated Resolution on the Construction of Vehicles (R.E.3) (TRANS/WP.29/78/Rev.1/Amend.2, annex 7) (also reproduced in annex 4 to this Regulation).

- 2.4.1. that their components as specified in paragraph 4.1. bear different trade names or marks;
- 2.4.2. that the characteristics of the materials constituting a component are different or that the components differ in shape or size. A change in the plating procedure (galvanization, aluminium coating, etc.) is not deemed to produce a difference of type;
- 2.4.3. that the operating principles of at least one component are different;
- 2.4.4. that their components are combined differently;
- 2.4.5. that the number of the intake and/or exhaust silencers is different.
- 2.5. "Sound reduction system component" means one of the individual parts which together form the sound reduction system.

Such components include, but are not limited to: the intake and exhaust pipes, the expansion chamber(s), the silencer itself, the components of acoustic insulating capsule (screen). Manifolds are not considered component of the sound reduction system.

- 2.6. "Maximum mass" means the technically permissible maximum mass in kg declared by the vehicle manufacturer (this mass may be greater than the maximum mass authorized by the national administration).
- 2.7. "Engine power" means the engine power expressed in kW (ECE) and measured by the ECE method pursuant to ECE Regulation No. 85.
- 2.8. "Rated Engine Speed, S" means the engine speed in 1/min (rpm) at which the engine develops its rated maximum net power as stated by the manufacturer.

If the rated maximum net power is reached at several engine speeds, the highest engine speed shall be used.

### 3. APPLICATION FOR APPROVAL

- 3.1. The application for approval of a vehicle type with regard to sound shall be submitted by its manufacturer or by his duly accredited representative.
- 3.2. It shall be accompanied by the under mentioned documents and the following particulars:
  - 3.2.1. a description of the vehicle type with regard to the items mentioned in paragraph 2.2. above. The numbers and/or symbols identifying the engine type and the vehicle type shall be specified;
  - 3.2.2. a list of the components, duly identified, constituting the sound reduction system;
  - 3.2.3. drawings of the assembled sound reduction system and an indication of its position on the vehicle;

- 3.2.4. drawings and part numbers of each component to enable it to be easily located and identified, and a specification of the materials used.
- 3.3. In the case of paragraph 2.2.6. the single vehicle, representative of the type in question, will be selected by the technical service conducting approval tests, in accordance with the vehicle manufacturer, as that with the lowest mass in running order with the shortest length and following the specification laid down in annex 3.
- 3.4. At the request of the technical service conducting approval tests, the vehicle manufacturer shall, in addition, submit a sample of the sound reduction system and an engine of at least the same cylinder capacity and rated maximum power as that fitted to the vehicle in respect of which type-approval is sought.

#### 4. MARKINGS

- 4.1. The components of the sound reduction system, excluding fixing hardware and piping, shall bear:
  - 4.1.1. the trade name or mark of the manufacturer of the sound reduction system and of its components; and
  - 4.1.2. the manufacturer's trade description.
- 4.2. These markings shall be clearly legible and be indelible even after fitting.

#### 5. APPROVAL

- 5.1. If the vehicle type submitted for approval pursuant to this Regulation meets the requirements of paragraph 6. and 7. below, approval of that vehicle type shall be granted.
- 5.2. An approval number shall be assigned to each type approved. Its first two digits (at present 03 corresponding to the 03 series of amendments which entered into force on [dd.mm.yyyy]) shall indicate the series of amendments incorporating the most recent major technical amendments made to the Regulation at the time of issue of the approval. The same Contracting Party may not assign the same number to the same vehicle type equipped with another type of sound reduction system or to another vehicle type.**
- 5.3. Notice of approval or of extension or of refusal or withdrawal of approval or of production definitely discontinued of a vehicle type pursuant to this Regulation shall be communicated to the Contracting Parties to the Agreement applying this Regulation, by means of a form conforming to the model in annex 1 to this Regulation.
- 5.4. There shall be affixed, conspicuously and in a readily accessible place specified on the approval form, to every vehicle conforming to a vehicle type approved under this Regulation an international approval mark consisting of:

- 5.4.1. a circle surrounding the letter "E" followed by the distinguishing number of the country which has granted approval 2/;
- 5.4.2. the number of this Regulation, followed by the letter "R", a dash and the approval number to the right of the circle prescribed in paragraph 5.4.1.
- 5.5. If the vehicle conforms to a vehicle type approved, under one or more other Regulations annexed to the Agreement, in the country which has granted approval under this Regulation, the symbol prescribed in paragraph 5.4.1. needs not be repeated; in such a case the regulation and approval numbers and the additional symbols of all the Regulations under which approval has been granted in the country which has granted approval under this Regulation shall be placed in vertical columns to the right of the symbol prescribed in paragraph 5.4.1.**
- 5.6. The approval mark shall be clearly legible and be indelible.
- 5.7. The approval mark shall be placed close to or on the vehicle data plate affixed by the manufacturer.
- 5.8. Annex 2 to this Regulation gives examples of arrangements of the approval mark.
- [5.9. The following information shall be provided on the vehicle in an easily accessible but not necessarily immediately visible location:**
- **the value in dB(A) recorded during the stationary test required by paragraph 6.2.1.**
  - **the engine speed, corresponding at 3/4S]**

## 6. SPECIFICATIONS

### 6.1. General specifications

2/ 1 for Germany, 2 for France, 3 for Italy, 4 for the Netherlands, 5 for Sweden, 6 for Belgium, 7 for Hungary, 8 for the Czech Republic, 9 for Spain, 10 for Yugoslavia, 11 for the United Kingdom, 12 for Austria, 13 for Luxembourg, 14 for Switzerland, 15 (vacant), 16 for Norway, 17 for Finland, 18 for Denmark, 19 for Romania, 20 for Poland, 21 for Portugal, 22 for the Russian Federation, 23 for Greece, 24 for Ireland, 25 for Croatia, 26 for Slovenia, 27 for Slovakia, 28 for Belarus, 29 for Estonia, 30 (vacant), 31 for Bosnia and Herzegovina, 32 for Latvia, 33 (vacant), 34 for Bulgaria, 35 (vacant), 36 Lithuania, 37 for Turkey, 38 (vacant), 39 Azerbaijan, 40 for The former Yugoslav Republic of Macedonia, 41 (vacant), 42 for the European Community (Approvals are granted by its Member States using their respective ECE symbol), 43 for Japan, 44 (vacant), 45 for Australia, 46 for Ukraine, 47 for South Africa and 48 for New Zealand. Subsequent numbers shall be assigned to other countries in the chronological order in which they ratify or accede to the Agreement Concerning the Adoption of Uniform Technical Prescriptions for Wheeled Vehicles, Equipment and Parts which can be Fitted and/or be Used on Wheeled Vehicles and the Conditions for Reciprocal Recognition of Approvals Granted on the Basis of these Prescriptions, and the numbers thus assigned shall be communicated by the Secretary-General of the United Nations to the Contracting Parties to the Agreement.

- 6.1.1. The vehicle, its engine and its sound reduction system shall be so designed, constructed and assembled as to enable the vehicle, in normal use, despite the vibration to which it may be subjected, to comply with the provisions of this Regulation.
- 6.1.2. The sound reduction system shall be so designed, constructed and assembled as to be able to reasonably resist the corrosive phenomena to which it is exposed having regard to the conditions of use of the vehicle.

6.2. Specifications regarding sound levels

6.2.1. Methods of measurement

- 6.2.1.1. The sound made by the vehicle type submitted for approval shall be measured by the methods described in annex 3 to this Regulation for the vehicle in motion and for the vehicle when stationary 3/; in the case of a vehicle powered by an electric motor, the emitted sound shall only be measured in motion.

Vehicles having a maximum permissible mass exceeding 2,800 kg must be subjected to an additional measurement of the compressed air sound with the vehicle stationary in accordance with the specifications of annex 6, if corresponding brake equipment is part of the vehicle.

- 6.2.1.2. The values measured in accordance with the provisions of paragraph 6.2.1.1. above shall be entered in the test report and on a form conforming to the model in annex 1 to this Regulation.

The values measured in decibel as specified in paragraph 6.2.1.1. above, mathematically rounded to the nearest integer value, must be recorded in a test report and a certificate corresponding to the model shown in annex 1.

**[6.2.2. Sound level limits \*\*/**

- 6.2.2.1. Subject to the provisions of paragraph 6.2.2.2. below, the sound level of vehicle types, as measured by the method described in paragraph 3.1. of annex 3 to this Regulation, shall not exceed the following limits:**

---

3/ A test is made on a stationary vehicle in order to provide a reference value for administrations which use this method to check vehicles in use.

\*\*/ **Discussion on sound level limits is necessary**

Vehicle categories		Limit values (dB(A))
6.2.2.1.1.	Vehicles used for the carriage of passengers and capable of having not more than nine seats, including the driver's seat	74
6.2.2.1.2.	Vehicles used for the carriage of passengers having more than nine seats, including the driver's seat, and a maximum authorized mass of more than 3.5 tonnes	
6.2.2.1.2.1.	with an engine power less than 150 kW (ECE)	78
6.2.2.1.2.2.	with an engine power of 150 kW (ECE) or above	80
6.2.2.1.3.	Vehicles used for the carriage of passengers having more than nine seats, including the driver's seat; vehicles used for the carriage of goods	
6.2.2.1.3.1.	with a maximum authorized mass not exceeding 2 tonnes	76
6.2.2.1.3.2.	with a maximum authorized mass greater than 2 tonnes but not exceeding 3.5 tonnes	77
6.2.2.1.4.	Vehicles used for the transport of goods with a maximum authorized mass exceeding 3.5 tonnes	
6.2.2.1.4.1.	with an engine power less than 75 kW (ECE)	77
6.2.2.1.4.2.	with an engine power of 75 kW (ECE) or above but less than 150 kW (ECE)	78
6.2.2.1.4.3.	with an engine power of 150 kW (ECE) or above	80

6.2.2.2. However,

6.2.2.2.1. For the vehicle types mentioned in paragraphs 6.2.2.1.1. and 6.2.2.1.3. equipped with a compression-ignition and direct-injection internal combustion engine, the limit values shall be increased by 1 dB(A);

6.2.2.2.2. For vehicle types designed for off-road <sup>4/</sup> use and with a maximum authorized mass above 2 tonnes, the limit values shall be increased:

---

<sup>4/</sup> In conformity with the definition given in the Consolidated Resolution on the Construction of Vehicles (R.E.3) (TRANS/WP.29/78/Rev.1/Amend.2, annex 7)



- 6.2.2.2.1. **by 1 dB(A) if they are equipped with an engine having a power of less than 150 kW (ECE);**
- 6.2.2.2.2. **by 2 dB(A) if they are equipped with an engine having a power of 150 kW (ECE) or above.**
- 6.2.2.2.3. **For vehicle types mentioned in paragraph 6.2.2.1.1. fitted with a gear box having more than four forward gears and equipped with an engine developing a maximum power greater than 140 kW (ECE) and having a maximum-power/maximum-mass ratio greater than 75 kW/t, the limit values shall be increased by 1 dB(A), if the speed at which the rear of the vehicle passes the line BB' in third gear is greater than 61 km/h.]**
- 6.2.3. Additional Sound Emission Provisions  
To cover off cycle emission provisions the requirements described in annex 10 are to be fulfilled.
- 6.3. SPECIFICATIONS REGARDING EXHAUST SYSTEMS CONTAINING FIBROUS MATERIALS
- 6.3.1. Requirements of annex 5 shall be applied.
- 7. MODIFICATION AND EXTENSION OF APPROVAL OF A VEHICLE TYPE
- 7.1. Every modification of the vehicle type shall be notified to the administrative department which approved the vehicle type. The department may then either:
  - 7.1.1. Consider that the modifications made are unlikely to have an appreciable adverse effect and that in any case the vehicle still complies with the requirements, or
  - 7.1.2. Require a further test report from the technical service responsible for conducting the tests.
- 7.2. Confirmation or refusal of approval, specifying the alterations shall be communicated by the procedure specified in paragraph 5.3. above to the Contracting Parties to the Agreement applying this Regulation.
- 7.3. The competent authority issuing the extension of approval shall assign a series number for such an extension and inform thereof the other Contracting Parties to the 1958 Agreement applying this Regulation by means of a communication form conforming to the model in annex 1 to this Regulation.

8. CONFORMITY OF PRODUCTION

The conformity of production procedures shall comply with those set out in the Agreement, Appendix 2 (E/ECE/324-E/ECE/TRANS/505/Rev.2) with the following requirements:

- 8.1. Vehicles approved to this Regulation shall be so manufactured as to conform to the type approved by meeting the requirements set forth in paragraph 6 above.
- 8.2. The minimum requirements for conformity of production control procedures set forth in annex 7 to this Regulation shall be complied with.
- 8.3. The authority which has granted type approval may at any time verify the conformity control methods applied in each production facility. The normal frequency of these verifications shall be one every two years.

9. PENALTIES FOR NON-CONFORMITY OF PRODUCTION

- 9.1. The approval granted in respect of a vehicle type pursuant to this Regulation may be withdrawn if the requirements set forth above are not met.
- 9.2. If a Contracting Party to the Agreement applying this Regulation withdraws an approval it has previously granted, it shall forthwith so notify the other Contracting Parties applying this Regulation, by means of a communication form conforming to the model in annex 1 to this Regulation.

10. PRODUCTION DEFINITELY DISCONTINUED

- 10.1. If the holder of the approval completely ceases to manufacture a vehicle type approved in accordance with this Regulation, he shall so inform the authority which granted the approval. Upon receiving the relevant communication that authority shall inform thereof the other Contracting Parties to the 1958 Agreement applying this Regulation by means of a communication form conforming to the model in annex 1 to this Regulation.

**[11. TRANSITIONAL PROVISIONS**

- 11.1. As from the official date of entry into force of the 03 series of amendments, no Contracting Party applying this Regulation shall refuse to grant ECE approval under this Regulation as amended by the 03 series of amendments.**
- 11.2. As from [dd.mm.yyyy], Contracting Parties applying this Regulation shall grant ECE approvals only if the vehicle type to be approved meets the requirements of this Regulation as amended by the 03 series of amendments.**
- 11.3. As from [dd.mm.yyyy], Contracting Parties applying this Regulation may refuse first national registration (first entry into service) of a vehicle which does not meet the requirements of the 03 series of amendments to this Regulation.**

**11.4. As from [dd.mm.yyyy], Contracting Parties applying this Regulation may not refuse first national registration (first entry into service) of a vehicle which does meet the requirements of the 03 series of amendments to this Regulation.]**

12. NAMES AND ADDRESSES OF TECHNICAL SERVICES RESPONSIBLE FOR CONDUCTING APPROVAL TESTS AND OF ADMINISTRATIVE DEPARTMENTS

The Contracting Parties to the 1958 Agreement applying this Regulation shall communicate to the United Nations Secretariat the names and addresses of the technical services responsible for conducting approval tests and of the administrative departments which grant approval and to which forms certifying approval or extension or refusal or withdrawal of approval, issued in other countries, are to be sent.

---

Annex 1

(Maximum format: A4 (210 x 297 mm))



COMMUNICATION

issued by: Name of administration:

.....  
.....  
.....

concerning: 2/ APPROVAL GRANTED  
APPROVAL EXTENDED  
APPROVAL REFUSED  
APPROVAL WITHDRAWN  
PRODUCTION DEFINITELY DISCONTINUED

**of a vehicle type with regard to its sound emission pursuant to ECE Regulation No. 51.**

Approval No.: .....

Extension No.: .....

- 1. Trade name or mark of the vehicle .....
- 2. Vehicle type .....
- 2.1. Maximum permissible mass including semi-trailer (where applicable) .....
- 2.2. Test mass. . . . . kg
- 2.3. Payload . . . . . kg
- 3. Manufacturer's name and address .....
- 4. If applicable, name and address of manufacturer's representative .....
- 5. Engine:
- 5.1. Manufacturer: .....
- 5.2. Type: .....
- 5.3. Model: .....
- 5.4. Rated maximum power (ECE): ..... kW at ..... min<sup>-1</sup>
- 5.5. Kind of engine: e.g. positive-ignition, compression ignition, etc. 3/  
.....
- 5.6. Cycles: two stroke or four-stroke (if applicable) .....
- 5.7. Cylinder capacity (if applicable) .....
- 6. Transmission: non-automatic gearbox/automatic gearbox 2/
- 6.1. Number of gears .....

- 7. Equipment:
  - 7.1. Exhaust silencer: .....
  - 7.1.1. Manufacturer or authorized representative (if any) .....
  - 7.1.2. Model: .....
  - 7.1.3. Type: ..... in accordance with drawing No.: .....
  - 7.2. Intake silencer: .....
  - 7.2.1. Manufacturer or authorized representative (if any) .....
  - 7.2.2. Model: .....
  - 7.2.3. Type: ..... in accordance with drawing No.: .....
  - 7.3. Elements of capsulation
    - 7.3.1. Elements of sound encapsulation as defined by the vehicle manufacturer.
    - 7.3.2. Manufacturer or authorized representative (if any)
  - 7.4. Tyres used for approval
    - 7.4.1. Tyre manufacturer, trade name, model (by axle): .....
    - 7.4.2. Tyre size (by axle): .....
    - 7.4.3. Type approval number (if available): .....
- 8. Measurements:
  - 8.1. Starting point of acceleration: . . . . . m before line AA'

8.2. [Sound level of moving vehicle:

MEASUREMENT RESULTS			
	Left-hand side dB(A) <u>4</u> /	Right-hand side dB(A) <u>4</u> /	Position of gear lever
First measurement			
Second measurement			
Third measurement			
Fourth measurement			
Test result:.....			dB(A)

- 8.3. Sound level of stationary vehicle:  
Position and orientation of microphone (according to diagrams in appendix of annex 3)

MEASUREMENT RESULTS		
	dB(A)	Engine speed
First measurement		
Second measurement		
Third measurement		
Test result: .....		dB(A)

8.4. Sound level of compressed air sound:

MEASUREMENT RESULTS, dB(A) <u>4/</u>			
	Left-hand side	Right-hand side	
First measurement			During the pressure regulator actuation
Second measurement			
First measurement			Service brake
Second measurement			
First measurement			Parking brake
Second measurement			
Test result: .....			dB(A)

8.4. Ambient conditions

8.4.1. Test site location: .....

8.4.2. Temperatures (°C): .....

8.4.2.1. Temperature of ambient air: .....

8.4.2.2. Temperature of test track surface: .....

8.4.3. Atmospheric pressure (hPa): .....

8.4.4. Humidity (%): .....

8.4.5. Wind speed (m/s): .....

8.4.6. Wind direction: .....

8.4.7. Background sound (dB(A)): .....

9. Vehicle submitted for approval on: .....

10. Technical service responsible for type-approval tests: .....

11. Date of test report issued by that service: .....

12. Number of test report issued by that service: .....

13. Type-approval in respect of sound levels is hereby granted / extended / refused / withdrawn 2/

14. Position of approval mark on the vehicle .....

15. Place .....

16. Date .....

17. Signature .....

18. The following documents, bearing the approval number shown above, are annexed to this communication:

drawings and/or photographs, diagrams and plans of the engine and of the sound reduction systems;

list of components, duly identified constituting the sound reduction systems.

19. Remarks: .....

.....  
 .....  
 .....

- 1/ Distinguishing number of the country which has granted/extended/refused/withdrawn approval (see approval provisions in the Regulations).
  - 2/ Strike out what does not apply.
  - 3/ If a non-conventional engine is used, this should be stated.
  - 4/ The measurement values are given with the 1 dB(A) deduction in accordance with the provisions of paragraph 6.2.2.2.
-

Annex 2

ARRANGEMENTS OF THE APPROVAL MARK

Model A

(See paragraph 5.4. of this Regulation)

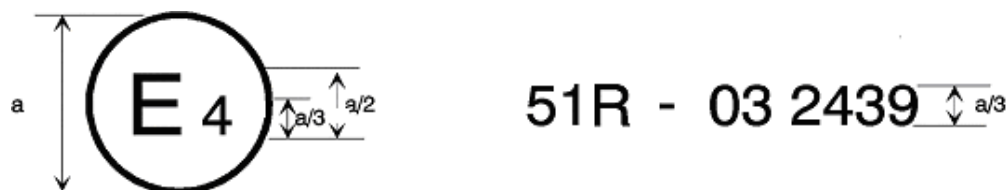

a = 8 mm min.

The above approval mark affixed to a vehicle shows that the vehicle type concerned has, with regard to its sound emission, been approved in the Netherlands (E 4) pursuant to Regulation No. 51 under approval No. 032439. The first two digits of the approval number indicate that Regulation No. 51 already included the 03 series of amendments when the approval was granted.

Model B

(See paragraph 5.5. of this Regulation)

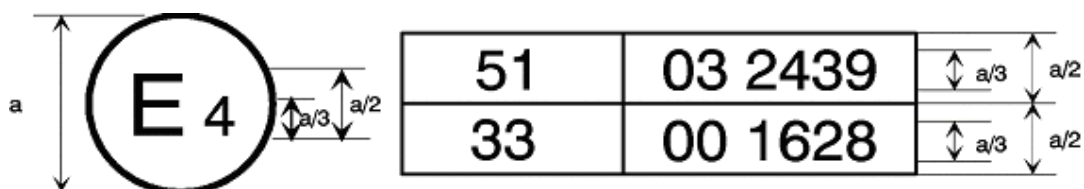

a = 8 mm min.

The above approval mark affixed to a vehicle shows that the vehicle type concerned has been approved in the Netherlands (E 4) pursuant to Regulations Nos. 51 and 33. <sup>1/</sup> The approval numbers indicate that, at the dates when the respective approvals were granted, Regulation No. 51 included the 03 series of amendments while Regulation No. 33 was in its original form.

<sup>1/</sup> The latter number is given as an example only.



### Annex 3

## METHODS AND INSTRUMENTS FOR MEASURING THE SOUND MADE BY MOTOR VEHICLES

### 1. MEASURING INSTRUMENTS

#### 1.1. Acoustic measurements

The apparatus used for measuring the sound level must be a precision sound-level meter of the type described in "Publication 61672-1(Date of version: 2002): Precision sound level meters", second edition, of the International Electrotechnical Commission (IEC). Measurements must be carried out using the "fast" response of the sound-level meter and the "A" weighting curve which are also described in that publication.

At the beginning and end of each set of measurements, the sound-level meter must be calibrated according to the manufacturer's instructions by means of an appropriate sound source (e.g. a piston phone). The test must be considered invalid if the sound-level meter errors registered during this calibration exceed 1 dB. The actual deviation shall be stated in the approval document (annex 1).

##### 1.1.1. General

The sound level meter or the equivalent measuring system, including the windscreen recommended by the manufacturer shall at least meet the requirements of Type 1 instruments in accordance with IEC 61672: **[Date of version: 2002]**.

The measurements shall be made using the frequency weighting A, and the time weighting F. When using a system that includes a periodic monitoring of the A-weighted sound pressure level, a reading should be made at a time interval not greater than 30 ms.

##### 1.1.2. Calibration

At the beginning and at the end of every measurement session, the entire measurement system shall be checked by means of a sound calibrator that fulfils the requirements for sound calibrators of at least precision Class 1 according to IEC 60942 (Date of version: 2003). Without any further adjustment the difference between the readings of two consecutive checks shall be less than or equal to 0.5 dB. If this value is exceeded, the results of the measurements obtained after the previous satisfactory check shall be discarded.

##### 1.1.3. Compliance with requirements

Compliance of the sound calibration device, with the requirements of IEC 60942, shall be verified once a year. Compliance of the instrumentation system, with the requirements of IEC 60651, shall be verified at least every 2 years. All compliance testing must be

conducted by a laboratory, which is authorized to perform calibrations traceable to the appropriate standards.

#### 1.1.4. Instrumentation for speed measurements

The rotational speed of the engine during the constant speed approach shall be measured with instruments meeting specification limits of  $\pm 2$  per cent or less.

The road speed of the vehicle shall be measured with a continuously measuring device meeting specification limits of  $\pm 1$  km/h or less.

#### 1.1.5. Meteorological instrumentation

The meteorological instrumentation used to monitor the environmental conditions during the test shall include the following devices, which meet at least the given accuracy:

- temperature measuring device,  $\pm 1$  °C
- wind speed measuring device,  $\pm 1.0$  m/s.
- barometric pressure measuring device,  $\pm 5$  hPa
- a relative humidity measuring device,  $\pm 5$  per cent

## 2. CONDITIONS OF MEASUREMENT

### 2.1. Site

2.1.1. The test site shall be substantially levelled. The surface of the test track shall be dry. The surface of the site must be in accordance with the provisions given in annex 8 to this Regulation. The test site shall be such that when a small omni-directional sound source is placed on its surface at the central point (intersection of the microphone line and the centre of the vehicle lane) see Figure 1 of annex 8, deviations from hemispherical divergence shall not exceed  $\pm 1$  dB.

This condition is deemed to be satisfied if the following requirements are met:

- Within a radius of 50 m around the centre of the track the space shall be free of large reflecting objects such as fences, rocks, bridges or buildings.
- The test track and the surface of the site shall be dry and free from absorbing materials such as powdery snow, or loose debris.
- In the vicinity of the microphone, there shall be no obstacle that could influence the acoustical field and no person shall remain between the microphone and the sound source. The meter observer shall be positioned so as not to influence the meter reading.

2.1.2. Measurements shall not be made under adverse weather conditions. It must be ensured that the results are not affected by gusts of wind.

The meteorological instrumentation should be positioned adjacent to the test area at a height of  $1.2 \text{ m} \pm 0.02 \text{ m}$ . The measurements shall be made when the ambient air temperature is within the range from  $5 \text{ }^\circ\text{C}$  to  $40 \text{ }^\circ\text{C}$ .

The tests shall not be carried out if the wind speed, including gusts, at microphone height exceeds  $5 \text{ m/s}$ , during the sound measurement interval.

A value representative of temperature, wind speed and direction, relative humidity, and barometric pressure shall be recorded during the sound measurement interval.

Any sound peak which appears to be unrelated to the characteristics of the general sound level of the vehicle shall be ignored in taking the readings.

- 2.1.3. It is recommended that the A-weighted background sound be  $15 \text{ dB}$  below the sound level produced by the vehicle under test, but it shall always be at least  $10 \text{ dB}$  below.

The background sound shall be measured for a duration of 10 seconds immediately before and after a series of vehicle tests. The maximum sound level shall be reported as the background sound level. The background noise level is defined as the maximum sound level during the measurement.

## 2.2. Vehicle

- 2.2.1. The vehicle shall be representative of vehicles to be put on the market as specified by the manufacturer. Measurements shall be made without any trailer, except in the case of non-separable vehicles. Measurements shall be made on vehicles at the test mass  $m_t$  specified according to the following table:

Vehicle Category	Vehicle Test Mass
M1	$m_t = m_{\text{ref}} = m_{\text{kerb}} + 75 \text{ kg}$ for the driver
<b>[N1 <math>\leq</math> 2,000 kg **/</b>	<b><math>m_t = m_{\text{ref}} = m_{\text{kerb}} + 75 \text{ kg}</math> for the driver or <math>m_t = m_{\text{kerb}} + 75 \text{ kg}</math> for the driver + payload (which is 50 per cent of maximal payload – 75 kg)</b>
<b>N1 &gt; 2,000 kg</b>	<b>on the decision of the manufacturer: <math>m_t = m_{\text{ref}} = m_{\text{kerb}} + 75 \text{ kg}</math> for the driver or <math>m_t = m_{\text{kerb}} + 75 \text{ kg}</math> for the driver + payload (which is 50 per cent of maximal payload – 75 kg)] */</b>

N2, N3	$m_t = 50 \text{ kg per kW rated power}$ The extra loading shall be placed above the rear axle. The extra loading is limited to 75 per cent of the max. weight allowed for the rear axle. The test mass shall be achieved with a tolerance of $\pm 5$ per cent The total weight for vehicles with more than two axles shall be the same as for a two-axle vehicle. The weight should be placed above the driven rear axle(s).
M2, M3	$m_t = m_{\text{kerb}} + 75 \text{ kg for the driver}$

\*/

**Decision will be taken after review of data**

\*\*/

**Maximum authorized mass of the vehicle**

- 2.2.2. The tyres to be used for the test shall be representative for the axle and shall be selected by the vehicle manufacturer (see annex 1). They shall correspond to one of the tyre sizes and types designated for the vehicle as original equipment. The tyre is or will be commercially available on the market at the same time as the vehicle 1/. The tyres shall be inflated to the pressure recommended by the tyre manufacturer for the test mass of the vehicle. The tyres shall have a tread depth of at least 80 per cent of the full tread depth.
- 2.2.3. Before the measurements are started, the engine shall be brought to its normal operating conditions.
- 2.2.4. If the vehicle is fitted with more than two-wheel drive, it shall be tested in the drive which is intended for normal road use.
- 2.2.5. If the vehicle is fitted with fan(s) having an automatic actuating mechanism, this system must not be interfered with to preclude normal operation during the measurements.
- 2.2.6. If the vehicle is equipped with an exhaust system containing fibrous materials, the exhaust system is to be conditioned before the test according to annex 5.

### 3. METHODS OF TESTING

#### 3.1. Measurement of sound emission of vehicles in motion

##### 3.1.1. General conditions of test (see annex 8, Figure 1)

##### 3.1.1.1. Reference point

---

1/ The tyre contribution for overall sound emission being important, this vehicle Regulation has taken into account the tyre/road sound emission regulations.

Depending on the design of the vehicle the following definitions for the reference point shall be used:

3.1.1.1.1. Category  $M_1, N_1$

- for front engine vehicles the reference point is the front end of the vehicle;
- for mid engine vehicles the reference point is the centre of the vehicle;
- for rear engine vehicles the reference point is the rear end of the vehicle.

3.1.1.1.2. Category  $M_2, M_3, N_2, N_3$

- The reference point is the border of the engine closest to the front of the vehicle.

3.1.1.2. At least four measurements shall be made on each side of the vehicle. Preliminary measurements may be made for adjustment purposes, but shall be disregarded.

3.1.1.3. The microphone must be located at a distance of  $7.5 \text{ m} \pm 0.05 \text{ m}$  from the reference line CC' (annex 8, Figure 1) of the track and  $1.2 \text{ m} \pm 0.02 \text{ m}$  above the ground.

The reference axis for free field conditions (see IEC 60651: [Date of version]) shall be horizontal and directed perpendicularly towards the path of the vehicle line CC'.

3.1.1.4. Two lines, AA' and BB', parallel to line PP' and situated respectively 10 m forward and 10 m rearward of that line shall be marked out on the test runway.

3.1.1.5. Constant speed test

During the constant speed test the throttle control shall be positioned to maintain a constant speed of 50 km/h with a tolerance of  $\pm 1 \text{ km/h}$  between AA' and BB'.

3.1.1.6. Acceleration

All accelerations in this paper are calculated using different speeds of the vehicle on the test track (see annex 8 Figure 1). The formulas given are used for the calculation of  $a_{\text{wot } i}$ ,  $a_{\text{wot } i+1}$  and  $a_{\text{wot test}}$ . The speed either at AA' or PP' is defined by the vehicle speed when the reference point passes AA' or PP'. The speed at BB' is defined when the rear of the vehicle passes BB'. The method used for determination of the acceleration shall be indicated in the test report.

Due to the definition of the reference point for the vehicle the length of the vehicle is considered different in the formula below. If the reference point is in the front of the vehicle, the  $l = l_{\text{veh}}$  is the length of vehicle, mid:  $l = \frac{1}{2} l_{\text{veh}}$  is  $1/2$ \*length of vehicle and rear:  $l = 0$

**[3.1.1.6.1. calculation procedure for vehicles with manual transmission, automatic transmission with lockable gears and CVT with lockable gears**

$$a_{\text{wot}} = ((v_{\text{BB}}/3.6)^2 - (v_{\text{AA}}/3.6)^2) / (2*(20+1)) \quad \text{equation 3.6-1}$$

Pre-acceleration shall be used if acceleration is delayed beyond AA'. The location of the starting point of the acceleration shall be reported in the communication form (annex 1).

**3.1.1.6.2. calculation procedure for vehicles with automatic transmission with non lockable gears**

$$a_{\text{wot}} = ((v_{\text{BB}}/3.6)^2 - (v_{\text{PP}}/3.6)^2) / (2*(10+1)) \quad \text{equation 3.6-2}$$

**3.1.1.6.3. calculation procedure for vehicles with CVT with non lockable gears)**

$$a_{\text{wot}} = (a_{\text{PP-BB}} - a_{\text{AA-BB}}) * (20+L)/10 + a_{\text{AA-BB}} \quad \text{equation 3.6-3}$$

where:

$$a_{\text{AA-BB}} = ((v_{\text{BB}}/3.6)^2 - (v_{\text{AA}}/3.6)^2) / (2*(20+1))$$

$$a_{\text{PP-BB}} = ((v_{\text{BB}}/3.6)^2 - (v_{\text{PP}}/3.6)^2) / (2*(10+1)) \quad ]$$

**3.1.1.6.4. Target acceleration**

The target acceleration  $a_{\text{urban}}$  defines the typical acceleration in urban traffic and is derived from statistical investigations. It is a function depending on the power-to-mass ratio (PMR) of a vehicle. That function is different for specific vehicle categories. PMR is defined as:

$$\text{PMR} = (P_n / m_{\text{ref}}) * 1000$$

**3.1.1.6.5. Reference acceleration**

The reference acceleration  $a_{\text{wot ref}}$  defines the required acceleration during the accelerated test on the test track. It is a function depending on the power-to-mass ratio of a vehicle. That function is different for specific vehicle categories.

**3.1.1.7. Partial power factor  $k_p$**

The partial power factor  $k_p$  is used for the weighted combination of the test results of the acceleration test and the constant speed test for vehicles of category  $M_1$  and  $N_1$ .

3.1.1.8. In the case of articulated vehicles consisting of two non-separable units regarded as a single vehicle, the semi-trailer shall be disregarded in determining when line BB' is crossed.

3.1.1.9. The maximum sound level expressed in A-weighted decibels (dB(A)) shall be measured as the vehicle is driven between lines AA' and BB'. Such value shall constitute the result of the measurement.

3.1.2. Specific test conditions for vehicles

3.1.2.1. Vehicles of category M<sub>1</sub>, N<sub>1</sub>

3.1.2.1.1. General conditions

The vehicle shall approach the line AA' with the path of its centreline following as closely as possible the line CC' (see Figure 1 of annex 8). If the vehicle is fitted with more than two-wheel drive, it shall be tested in the drive selection which is intended for normal road use.

If the vehicle is fitted with an auxiliary manual transmission or a multi-gear axle, the position used for normal urban driving shall be used. In all cases, the gear ratios for slow movements, parking or braking shall be excluded.

The test mass of the vehicle shall be according to the table of paragraph 2.2.1.

3.1.2.1.2. Test speed

The test speed  $v_{\text{test}}$  is 50 km/h  $\pm$  1 km/h. The test speed must be reached, when the reference point according to paragraph 3.1.1.1. is at line PP'.

3.1.2.1.3. Reference acceleration

The reference acceleration  $a_{\text{wot ref}}$  is defined by:

$$\begin{aligned} a_{\text{wot ref}} &= 0.0092 * (\text{PMR}) + 0.6318 && \text{for PMR} < 50 \\ a_{\text{wot ref}} &= 1.60 * \log(\text{PMR}) - 1.630 && \text{for PMR} \geq 50 \end{aligned}$$

3.1.2.1.4. Target acceleration

The target acceleration  $a_{\text{urban}}$  is defined by

$$\begin{aligned} a_{\text{urban}} &= 0.005 * (\text{PMR}) + 0.6651 && \text{for PMR} < 50 \\ a_{\text{urban}} &= 0.750 * \log(\text{PMR}) - 0.365 && \text{for PMR} \geq 50 \end{aligned}$$

3.1.2.1.5. Gear ratio selection

### 3.1.2.1.5.1. Manual transmission

The selection of gear ratios for the test depends on their specific acceleration potential  $a_{\text{wot}}$  under full throttle condition, according to the reference acceleration  $a_{\text{wot ref}}$  required for the full throttle acceleration test.

The following conditions for selection of gear ratios are possible:

- If one specific gear ratio gives an acceleration in a tolerance band of  $\pm 5$  per cent of the reference acceleration  $a_{\text{wot ref}}$ , test with that gear ratio.
- If none of the gear ratios give the required acceleration, then choose a gear ratio  $i$ , with an acceleration higher and a gear ratio  $i+1$ , with an acceleration lower than the reference acceleration. If the acceleration value in gear ratio  $i$  does not exceed  $2.0 \text{ m/s}^2$ , use both gear ratios for the test. The weighting ratio in relation to the reference acceleration  $a_{\text{wot ref}}$  is calculated by:

$$k = (a_{\text{wot ref}} - a_{\text{wot (i+1)}}) / (a_{\text{wot (i)}} - a_{\text{wot (i+1)}})$$

- if the acceleration value of gear ratio  $i$  or  $i+1$  exceeds  $2.0 \text{ m/s}^2$ , the first gear ratio shall be used that gives an acceleration below  $2.0 \text{ m/s}^2$ . No other gear shall be used. The achieved acceleration  $a_{\text{wot test}}$  during the test shall be used for the calculation of the part power factor  $k_p$  instead of  $a_{\text{wot ref}}$ .
- If the vehicle has a transmission in which there is only one selection for the gear ratio the full throttle test is carried out in this vehicle gear selection. The achieved acceleration is then used for the calculation of the part power factor  $k_p$  instead of  $a_{\text{wot ref}}$ .

### 3.1.2.1.5.2. Automatic transmission, adaptive transmissions and transmissions with variable gear ratio

The gear selector position for normal urban driving shall be used. The test may then include a gear change to a lower range and a higher acceleration. A gear change to a higher range and a lower acceleration is not allowed. A gear shifting to a gear ratio which is not used in urban traffic shall be avoided. It is permitted to establish and use electronic or mechanic devices to lock a gear ratio according to normal urban use. But all other conditions shall be met.

### 3.1.2.1.6. Acceleration test

**[When the front of the vehicle reaches AA' the acceleration control unit shall be fully engaged as quickly as practically possible (without operating the automatic downshift to a lower range than normally used in urban driving) and kept in that position until the rear of the vehicle reaches BB'. The acceleration control**



**unit must then be released as quickly as possible. Pre-acceleration shall be used, if acceleration is delayed beyond line AA'. The location of the starting point of the acceleration shall be reported in the communication form (annex 1). The accelerator control shall be fully engaged at an appropriate position on the approach such that acceleration begins at AA'. This position of engagement shall be reported in the communication form [to be extended by United Kingdom].]**

3.1.2.1.7. Constant speed test

The constant speed test has to be carried out with the same gears specified for acceleration test. During the constant speed test the acceleration control shall be positioned to maintain a constant speed between AA' and BB' as specified.

3.1.2.3. Vehicles of categories M<sub>2</sub>, M<sub>3</sub>, N<sub>2</sub>, N<sub>3</sub>

3.1.2.3.1. General conditions

The vehicle shall approach the line AA' with the path of its centreline following as closely as possible the line CC' (see annex 8, Figure 1). The test has to be conducted without a trailer or semi-trailer. If a trailer is not readily separable from the towing vehicle this one has to be ignored when considering the crossing of line BB'. If the vehicle incorporates equipment such as a concrete mixer, a compressor, etc, this equipment shall not be in operation during the test. The test mass of the vehicle shall be according to the table of paragraph 2.2.1.

3.1.2.3.2. Target conditions

3.1.2.3.2.1. Category M<sub>2</sub>, N<sub>2</sub>

When the reference point passes line BB', the engine revolution  $n_{BB'}$  shall be between 70 per cent and 74 per cent of speed S, at which the engine develops its rated maximum power, and the vehicle speed shall be 35 km/h  $\pm$  5 km/h. Between line AA' and line BB' a stable acceleration condition must be ensured.

3.1.2.3.2.2. Category M<sub>3</sub>, N<sub>3</sub>

When the reference point passes line BB', the engine revolution  $n_{BB'}$  shall be between 85 per cent and 89 per cent of speed S, at which the engine develops its rated maximum power, and the vehicle speed shall be 35 km/h  $\pm$  5 km/h. Between line AA' and line BB' a stable acceleration condition must be ensured.

3.1.2.3.3. Gear selection

3.1.2.3.3.1. Manual transmissions

**[Stable acceleration condition must be ensured. The gear choice is determined by the target conditions. If the difference in speed exceeds the given tolerance, then two gears should be tested, one above and one below the target speed.]**

**If more than one gear fulfils the target conditions take that gear which is closest to 35 km/h. If no gear fulfils the target condition for  $v_{\text{test}}$  two gears shall be tested, one above and one below  $v_{\text{test}}$ . The target engine speed shall be reached in any condition.**

**A stable acceleration condition must be ensured. If a stable acceleration cannot be ensured in a gear, this gear has to be disregarded.]**

3.1.2.3.3.2. Automatic transmissions, Adaptive transmissions and transmissions with variable gear ratio

The gear selector position for normal urban driving shall be used. The test may then include a gear change to a lower range and a higher acceleration. A gear change to a higher range and a lower acceleration is not allowed. A gear shifting to a gear ratio which is not used in urban traffic shall be avoided. It is permitted to establish and use electronic or mechanic devices to lock a gear ratio according to normal urban use. But all other conditions shall be met.

3.1.2.3.3.3. Adaptive transmissions and transmissions with variable gear ratio

To ensure the reproducibility it is permitted to establish and use electronic or mechanic devices to lock a gear ratio according to normal urban use.

3.1.2.3.4. Wide open throttle test

When the reference point of the vehicle reaches the line AA' the accelerator control shall be fully engaged (without operating the automatic downshift to a lower range than normally used in urban driving) and held fully engaged until the reference point is 5 m behind line BB'. The accelerator control shall then be released.

3.1.3. INTERPRETATION OF RESULTS

The maximum A-weighted sound pressure level indicated during each passage of the vehicle between the two lines AA' and BB' (see annex 8, Figure 1) shall be noted and mathematically rounded to the first decimal place. If a sound peak obviously out of character with the general sound pressure level is observed, the measurement shall be discarded. **At least four measurements both for the acceleration test and the constant speed test shall be made on each side of the vehicle (left and right side**

**simultaneously or not) and for each gear ratio. The results shall be considered valid when four measurements within a group of consecutive measurements on each side of the vehicle are within 2 dB(A), for the given side of the vehicle.** The results of each side shall be averaged separately. The intermediate result is the higher value of the two averages mathematically rounded to the first decimal place. **[To allow for lack of precision in the measuring instruments the figures read from it during measurement shall each be reduced by 1 dB(A).]**

### 3.1.3.1. Vehicles of categories M<sub>1</sub>, N<sub>1</sub>

The calculated values for the wide open throttle test and the constant speed test are given by:

$$L_{\text{wot rep}} = L_{\text{wot (i+1)}} + k * (L_{\text{wot(i)}} - L_{\text{wot (i+1)}})$$

$$L_{\text{crs rep}} = L_{\text{crs(i+1)}} + k * (L_{\text{crs (i)}} - L_{\text{crs (i+1)}})$$

Where:  $k = (a_{\text{wot ref}} - a_{\text{wot (i+1)}}) / (a_{\text{wot (i)}} - a_{\text{wot (i+1)}})$

In the case of a single gear ratio test the values are the test result of each test.

The final result is calculated by combining  $L_{\text{wot rep}}$  and  $L_{\text{crs rep}}$ . The equation is:

$$L_{\text{urban}} = L_{\text{wot rep}} - k_p * (L_{\text{wot rep}} - L_{\text{crs rep}})$$

The weighting factor  $k_p$  gives the part power factor for urban driving. In cases other than a single gear test  $k_p$  is calculated by

$$k_p = 1 - (a_{\text{urban}} / a_{\text{wot ref}})$$

If only one gear is specified for the test,  $k_p$  is given by

$$k_p = 1 - (a_{\text{urban}} / a_{\text{wot test}})$$

In cases where  $a_{\text{wot test}}$  is less than  $a_{\text{urban}}$ :

$$k_p = 0$$

### 3.1.3.2. Vehicles of categories M<sub>2</sub>, M<sub>3</sub>, N<sub>2</sub>, N<sub>3</sub>

When one gear is tested the final result is the intermediate result. When two gears are tested the arithmetic mean of the intermediate results shall be calculated.

3.2. Measurement of sound emitted by stationary vehicles

3.2.1. Sound level in the vicinity of vehicles

In order to facilitate subsequent checks on vehicles in use, the sound level must be measured close to the exhaust system outlet in accordance with the following requirements and the measurement results entered in the test report drawn up for the purpose of issuing the certificate referred to in annex 1.

3.2.2. Acoustic measurements

A precision sound level meter as defined in paragraph 1.1. of this annex must be used for the measurements.

3.2.3. Test site - local conditions (Figure 1)

3.2.3.1. Measurements should be made on a stationary vehicle in an area which corresponds to that for measurements of vehicles in motion and therefore corresponds to the provisions given in annex 8 to this Regulation.

3.2.3.2. During the test nobody shall be in the measurement area, except the observer and the driver whose presence must have no influence on the metre reading.

3.2.4. Disturbance sound and wind interference

Readings on the measuring instruments produced by ambient sound and wind must be at least 10 dB(A) below the sound level to be measured. A suitable windscreen may be fitted to the microphone provided that account is taken of its effect on the sensitivity of the microphone.

3.2.5. Measuring method

3.2.5.1. Nature and number of measurements

The maximum sound level expressed in A-weighted decibels (dB(A)) must be measured during the operating period referred to in paragraph 3.2.5.3.2.1.

At least three measurements must be taken at each measuring point.

3.2.5.2. Positioning and preparation of the vehicle

The vehicle shall be located in the centre part of the test area with the gear level in neutral position and the clutch engaged. If the design of the vehicle does not allow this, the vehicle shall be tested in conformity with the manufacturer's prescriptions for stationary engine testing. Before each series of measurements, the engine must be brought to its normal operating condition, as specified by the manufacturer.

If the vehicle is fitted with fan(s) having an automatic actuating mechanism, this system shall not be interfered with during the sound level measurements.

3.2.5.3. Measuring of sound in proximity to the exhaust  
(see appendix, Figure 1)

3.2.5.3.1. Positions of the microphone

3.2.5.3.1.1. The height of the microphone above the ground should be equal to that of the outlet pipe of the exhaust gases, but in any event shall be limited to a minimum value of 0.2 m.

3.2.5.3.1.2. The microphone must be pointed towards the orifice of the gas flow and located at a distance of 0.5 m from the latter.

3.2.5.3.1.3. Its axis of maximum sensitivity must be parallel to the ground and must make an angle of  $45^{\circ} \pm 10^{\circ}$  with the vertical plane containing the direction of the gas flow. The instructions of the manufacturer of the sound level meter with regard to this axis must be respected. In relation to this plane, the microphone shall be placed in such a way as to obtain the maximum distance from the longitudinal median plane of the vehicle; in case of doubt, the position which gives the maximum distance from the contour of the vehicle shall be selected.

3.2.5.3.1.4. In the case of an exhaust provided with two or more outlets spaced less than 0.3 m apart and which are connected to the same silencer, only one measurement is made; the microphone position is related to the outlet nearest to one extreme edge of the vehicle or, when such outlet does not exist, to the outlet which is the highest above the ground.

3.2.5.3.1.5. For vehicles with a vertical exhaust (e.g. commercial vehicles) the microphone should be placed at the height of the exhaust outlet. Its axis should be vertical and oriented upwards. It should be placed at a distance of 0.5 m from the side of the vehicle nearest to the exhaust.

3.2.5.3.1.6. For vehicles having an exhaust provided with outlets spaced more than 0.3 m apart, one measurement is made for each outlet as if it were the only one, and the highest level is noted.

3.2.5.3.2. Operating conditions of the engine

3.2.5.3.2.1. **[The engine is operated at a constant speed having the following value:  $3/4 S$  for both controlled ignition engines and for diesel engines.]**

3.2.5.3.2.2. **[When constant engine speed is reached, the throttle shall be returned swiftly to the idle position. The sound level shall be measured during a period of**

**operation consisting of a brief maintenance of constant engine speed and throughout the entire deceleration period, the maximum sound level meter reading being taken as the test value.]**

3.2.6. Results

3.2.6.1. Readings, mathematically rounded to the first decimal place, shall be taken from the measuring instrument.

Only those values obtained from three consecutive measurements which do not differ by more than 2 dB(A) respectively will be taken into consideration.

3.2.6.2. The three values shall be averaged and mathematically rounded to the first decimal place. They shall constitute the test result.

---

Annex 3 – Appendix

Measuring positions for stationary vehicles

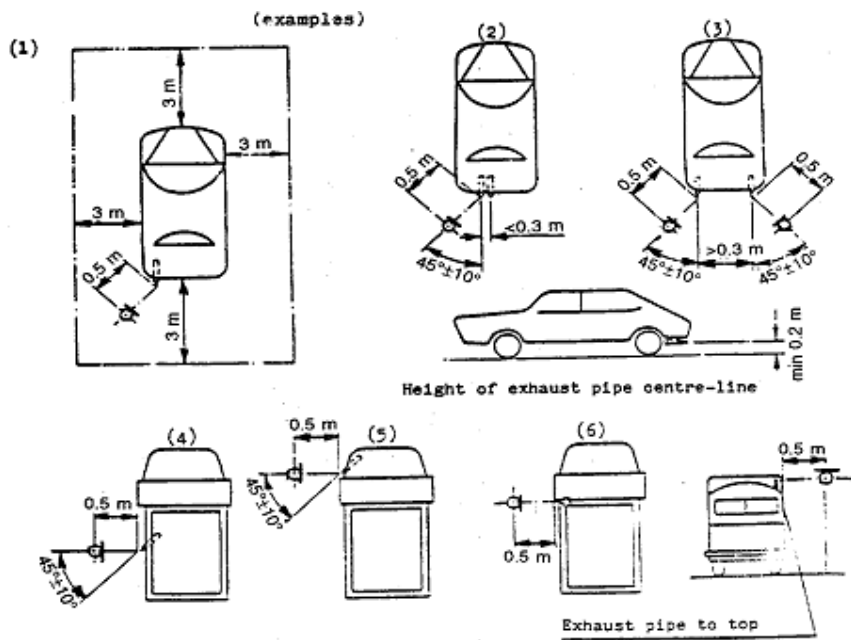

Figure 1

Annex 4

CLASSIFICATION OF VEHICLES 1/

1. CATEGORY L (Not applicable for this Regulation)
2. CATEGORY M - POWER-DRIVEN VEHICLES HAVING AT LEAST FOUR WHEELS AND USED FOR THE CARRIAGE OF PASSENGERS
  - 2.1. Category M<sub>1</sub>:

Vehicles used for the carriage of passengers and comprising not more than eight seats in addition to the driver's seat.
  - 2.2. Category M<sub>2</sub>:

Vehicles used for the carriage of passengers, comprising more than eight seats in addition to the driver's seat, and having a maximum mass not exceeding 5 tonnes.
  - 2.3. Category M<sub>3</sub>:

Vehicles used for the carriage of passengers, comprising more than eight seats in addition to the driver's seat, and having a maximum mass exceeding 5 tonnes.
  - 2.4. Vehicles of category M<sub>2</sub> and M<sub>3</sub> belong to:
    - (i) one or more of the three classes (Class I, Class II, Class III) in accordance with Regulations Nos. 36 and 107.
    - (ii) one of the two classes (Class A, Class B) in accordance with Regulation No. 52.
  - 2.4.1. Class I:

Vehicles constructed with areas for standing passengers, to allow frequent passenger movement.
  - 2.4.2. Class II:

Vehicles constructed principally for the carriage of seated passengers, and designed to allow the carriage of standing passengers in the gangway and/or in an area which does not exceed the space provided for two double seats.
  - 2.4.3. Class III:

---

1/ In conformity with the Consolidated Resolution on the Construction of Vehicles (R.E.3) (TRANS/WP.29/78/Rev.1/Amend.2, annex 7)



Vehicles constructed exclusively for the carriage of seated passengers.

2.4.4. Class A:

Vehicles designed to carry standing passengers; a vehicle of this class has seats and may have provisions for standing passengers.

2.4.5. Class B:

Vehicles not designed to carry standing passengers; a vehicle of this class has no provision for standing passengers.

2.5. Remarks:

2.5.1. 'Articulated bus or coach' is a vehicle which consists of two or more rigid sections which articulate relative to one another; the passengers compartments of each section intercommunicate so that passengers can move freely between them; the rigid sections are permanently connected so that they can only be separated by an operation involving facilities which are normally only found in a workshop.

2.5.2. Articulated buses or coaches comprising two or more non-separable but articulated units shall be considered as single vehicles.

2.5.3. In the case of a towing vehicle designed to be coupled to a semi trailer (tractor for semi trailer), the mass to be considered for classifying the vehicle is the mass of the tractor vehicle in running trim, increased by the mass corresponding to the maximum static vertical load transferred to the tractor vehicle by the semi trailer and, where applicable, by the maximum mass of the tractor vehicle's own load.

2.5.4. 'Mass of a vehicle in running order' means the mass of an unladen vehicle with bodywork, and with coupling device in the case of a towing vehicle, or the mass of the chassis with cab if the manufacturer does not fit the bodywork and/or coupling device, including coolant, oils, 90 per cent of fuel, 100 per cent of other liquids except used waters, tools, spare wheel, driver (75 kg) and, for buses and coaches, the mass of the crew member (75 kg) if there is a crew seat in the vehicle.

3. CATEGORY N - POWER-DRIVEN VEHICLES HAVING AT LEAST FOUR WHEELS AND USED FOR THE CARRIAGE OF GOODS

3.1. Category N<sub>1</sub>:

Vehicles used for the carriage of goods and having a maximum mass not exceeding 3.5 tonnes.

3.2. Category N<sub>2</sub>:

Vehicles used for the carriage of goods and having a maximum mass exceeding 3.5 tonnes but not exceeding 12 tonnes.

3.3. Category N<sub>3</sub>:

Vehicles used for the carriage of goods and having a maximum mass exceeding 12 tonnes.

3.4. Remarks:

3.4.1. In the case of a towing vehicle designed to be coupled to a semi-trailer (tractor for semi-trailer), the mass to be considered for classifying the vehicle is the mass of the tractor vehicle in running trim, increased by the mass corresponding to the maximum static vertical load transferred to the tractor vehicle by the semi-trailer and, where applicable, by the maximum mass of the tractor vehicle's own load.

3.4.2. The equipment and installations carried on certain special-purpose vehicles (crane vehicles, workshop vehicles, publicity vehicles, etc.) are regarded as being equivalent to goods.

---

Annex 5

## EXHAUST SYSTEMS CONTAINING FIBROUS MATERIALS

1. Fibrous materials shall not be used in the construction of silencers unless suitable measures are undertaken at the design or production stages to ensure that the efficiency required to comply with the limits imposed in paragraph 6.2.2. of this Regulation is achieved on the road. Such a silencer shall be considered to be efficient on the road if the exhaust gases are not in contact with the fibrous materials or if the silencer of the prototype vehicle tested in accordance with the requirements of paragraphs 3.1. and 3.2. of this Regulation has been put into a normal state for road use before the sound-level measurements are taken. This can be achieved by using one of the three tests described in paragraphs 1.1., 1.2. and 1.3. below or by removing the fibrous materials from the silencer.
  - 1.1. Continuous road operation for 10,000 km
    - 1.1.1. About half this operation consists of town driving and the other half of long-distance runs at high speed; continuous road operation can be replaced by a corresponding test-track programme.
    - 1.1.2. The two speed regimes should be alternated on several occasions.
    - 1.1.3. The complete test programme must include a minimum of 10 breaks of at least three hours duration in order to reproduce the effects of cooling and any condensation which may occur.
  - 1.2. Conditioning on a test bench
    - 1.2.1. Using standard parts and observing the vehicle manufacturer's instructions, the exhaust system or components thereof must be fitted to the vehicle referred to in paragraph 3.3. of this Regulation or the engine referred to in paragraph 3.4. of this Regulation. In the former case the vehicle must be mounted on a roller dynamometer. In the second case, the engine must be coupled to a dynamometer.
    - 1.2.2. The test must be conducted in six six-hour periods with a break of at least 12 hours between each period in order to reproduce the effects of cooling any condensation which may occur.
    - 1.2.3. During each six-hour period, the engine shall be run, under the following conditions in turn:
      - (1) Five minutes at idling speed;
      - (2) One-hour sequence under 1/4 load at 3/4 of rated maximum speed (S);
      - (3) One-hour sequence under 1/2 load at 3/4 of rated maximum speed (S);
      - (4) 10-minute sequence under full load at 3/4 of rated maximum speed (S);
      - (5) 15-minute sequence under 1/2 load at rated maximum speed (S);

- (6) 30-minute sequence under 1/4 load at rated maximum speed (S).

Total duration of the six sequences: three hours.

Each period must comprise two sets of the six above-mentioned sequences.

- 1.2.4. During the test, the silencer must not be cooled by a forced draught simulating normal airflow around the vehicle. Nevertheless, at the request of the manufacturer, the silencer may be cooled in order not to exceed the temperature recorded at its inlet when the vehicle is running at maximum speed.

1.3. Conditioning by pulsation

- 1.3.1. The exhaust system or components thereof must be fitted to the vehicle referred to in paragraph 3.3. of this Regulation or the engine referred to in paragraph 3.4. of this Regulation. In the former case the vehicle must be mounted on a roller dynamometer.

In the second case, the engine must be mounted on a dynamometer. The test apparatus, a detailed diagram of which is shown in Figure 1 of the appendix to this annex must be fitted at the outlet of the exhaust system. Any other apparatus providing equivalent results is acceptable.

- 1.3.2. The test apparatus must be adjusted in a such a way that the exhaust-gas flow is alternatively interrupted and re-established by the quick-action valve for 2,500 cycles.
- 1.3.3. The valve must open when the exhaust-gas back pressure, measured at least 100 mm downstream of the intake flange, reaches a value of between 0.35 and 0.40 bar. It must close when this pressure does not differ by more than 10 per cent from its stabilized value with the valve open.
- 1.3.4. The time-delay switch shall be set for the duration of gas exhaust resulting from the provisions laid down in paragraph 1.3.3. above.
- 1.3.5. Engine speed must be 75 per cent of the speed (S) at which the engine develops maximum power.
- 1.3.6. The power indicated by the dynamometer must be 50 per cent of the full-throttle power measured at 75 per cent of engine speed (S).
- 1.3.7. Any drain holes must be closed off during the test.
- 1.3.8. The entire test must be completed within 48 hours.

If necessary, one cooling period will be observed after each hour.

---

Annex 5 - Appendix

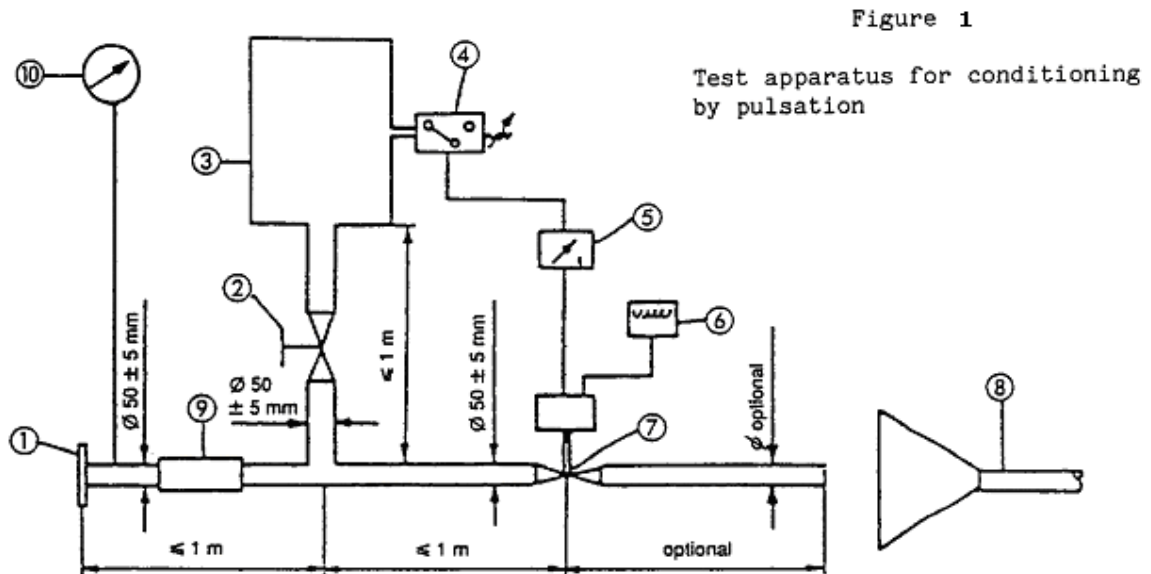

1. inlet flange or sleeve for connection to the rear of the test exhaust system.
2. Hand-operated regulating valve.
3. Compensating reservoir with a maximum capacity of 40 l and a filling time of not less than one second.
4. Pressure switch with an operating range of 0.05 to 2.5 bar.
5. Time delay switch.
6. Pulse counter.
7. Quick-acting valve, such as exhaust brake valve 60 mm in diameter, operated by a pneumatic cylinder with an output of 120 N at 4 bar. The response time, both when opening and closing, must not exceed 0.5 second.
8. Exhaust gas evacuation.
9. Flexible pipe.
10. Pressure gauge.

## Annex 6

### COMPRESSED AIR SOUND

#### 1. Method of measurement

The measurement is performed at microphone positions 2 and 6 according to Figure 1, with the vehicle stationary. The highest A-weighted sound level is registered during venting the pressure regulator and during ventilating after the use of both the service and parking brakes.

The sound during venting the pressure regulator is measured with the engine at idling speed. The ventilating sound is registered while operating the service and parking brakes; before each measurement, the air-compressor unit has to be brought up to the highest permissible operating pressure, and then the engine switched off.

#### 2. Evaluation of the results

For all microphone positions two measurements are taken. In order to compensate for inaccuracies of the measuring equipment, the metre reading is reduced by 1 dB(A), and the reduced value is taken as the result of measurement. The results are taken as valid if the difference between the measurements at one microphone position does not exceed 2 dB(A). The highest value measured is taken as the result. If this value exceeds the sound limit by 1 dB(A), two additional measurements are to be taken at the corresponding microphone position. In this case, three out of the four results of measurement obtained at this position have to comply with the sound limit.

#### 3. Limiting value

The sound level shall not exceed the limit of 72 dB(A).

---

Annex 6 - Appendix

Figure 1: Microphone positions for measurement of compressed air sound

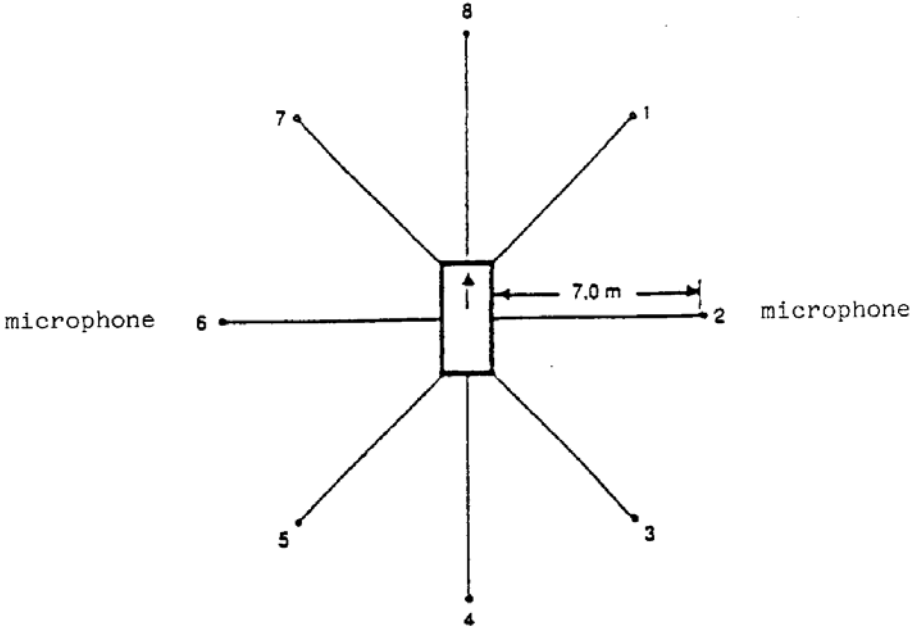

The measurement is performed at the stationary vehicle according to Figure 1, using two microphone positions at a distance of 7 m from the contour of the vehicles, and at 1.2 m above ground.

---

Annex 7

CHECKS ON CONFORMITY OF PRODUCTION

1. General

These requirements are consistent with the test to be held to check conformity of production according to paragraph 8. of this Regulation.

2. Testing procedure

The test site and measuring instruments shall be those as described in annex 3.

2.1. The vehicle(s) under test shall be subjected to the test for measurement of sound of vehicle in motion as described in paragraph 3.1. of annex 3.

2.2. Compressed air noise sound

Vehicles having maximum mass exceeding 2,800 kg and equipped with compressed air systems must be subjected to an additional test for measurement of the compressed air sound as described in paragraph 1. of annex 6.

3. Sampling

One vehicle has to be chosen. If after the test of paragraph 4.1. the vehicle is not considered to conform to the requirements of this Regulation, two more vehicles have to be tested.

4. Evaluation of the results

4.1. If the sound level of the vehicle tested pursuant to paragraphs 1. and 2. does not exceed by more than 1 dB(A) the limit value prescribed in paragraph 6.2.2. of this Regulation, for measurement according to paragraph 2.1. above, and in paragraph 3. of annex 6 to this Regulation, for measurement according to paragraph 2.2. above, the vehicle type shall be considered to conform to the requirements of this Regulation.

4.2. If the vehicle tested according to paragraph 4.1. does not satisfy the requirements laid down in that paragraph, two more vehicles of the same type have to be tested pursuant to paragraphs 1. and 2.

4.3. If the sound level of the second and/or third vehicle of paragraph 4.2. exceeds by more than 1 dB(A) the limit values prescribed in paragraph 6.2.2. of this Regulation, the vehicle type shall be considered not to conform to the requirements of this Regulation and the manufacturer shall take the necessary measures to re-establish the conformity.

---



Annex 8

## SPECIFICATIONS FOR THE TEST SITE

1. Introduction

This annex describes the specifications relating to the physical characteristics and the laying of the test track. These specifications based on a special standard 1/ describe the required physical characteristics as well as the test methods for these characteristics.

2. Required characteristics of the surface

A surface is considered to conform to this standard provided that the texture and voids content or sound absorption coefficient have been measured and found to fulfil all the requirements of paragraphs 2.1. to 2.4. below and provided that the design requirements (paragraph 3.2.) have been met.

2.1. Residual voids content

The residual voids content,  $V_C$ , of the test track paving mixture shall not exceed 8 per cent. For the measurement procedure, see paragraph 4.1.

2.2. Sound absorption coefficient

If the surface fails to comply with the residual voids content requirement, the surface is acceptable only if its sound absorption coefficient,  $\alpha \leq 0.10$ . For the measurement procedure, see paragraph 4.2. The requirement of paragraphs 2.1. and 2.2. is met also if only sound absorption has been measured and found to be  $\alpha \leq 0.10$ .

Note: The most relevant characteristic is the sound absorption, although the residual voids content is more familiar among road constructors. However, sound absorption needs to be measured only if the surface fails to comply with the voids requirement. This is motivated because the latter is connected with relatively large uncertainties in terms of both measurements and relevance and some surfaces therefore erroneously may be rejected when based only on the voids measurement.

2.3. Texture depth

The texture depth (TD) measured according to the volumetric method (see paragraph 4.3. below) shall be:

$$TD \geq 0.4 \text{ mm}$$

---

1/ [ISO 10844:1994. currently under revision of ISO; to be updated]

2.4. Homogeneity of the surface

Every practical effort shall be taken to ensure that the surface is made to be as homogeneous as possible within the test area. This includes the texture and voids content, but it should also be observed that if the rolling process results in more effective rolling at some places than others, the texture may be different and unevenness causing bumps may also occur.

2.5. Period of testing

In order to check whether the surface continues to conform to the texture and voids content or sound absorption requirements stipulated in this standard, periodic testing of the surface shall be done at the following intervals:

- (a) For residual voids content or sound absorption:

when the surface is new;

if the surface meets the requirements when new, no further periodical testing is required. If it does not meet the requirement when it is new, it may do later because surfaces tend to become clogged and compacted with time.

- (b) For texture depth (TD):

when the surface is new;

when the sound testing starts (NB: not before four weeks after laying);

then every twelve months.

3. Test surface design

3.1. Area

When designing the test track layout it is important to ensure that, as a minimum requirement, the area traversed by the vehicles running through the test strip is covered with the specified test material with suitable margins for safe and practical driving. This will require that the width of the track is at least 3 m and the length of the track extends beyond lines AA' and BB' by at least 10 m at either end. Figure 1 shows a plan of a suitable test site and indicates the minimum area which shall be machine laid and machine compacted with the specified test surface material. According to annex 3, paragraph 3.1.1.1., measurements have to be made on each side of the vehicle. This can be made either by measuring with two microphone locations (one on each side of the track) and driving in one direction, or measuring with a microphone only on one side of the track but driving the vehicle in two directions. If the latter method is used, then there are no surface requirements on that side of the track where there is no microphone.

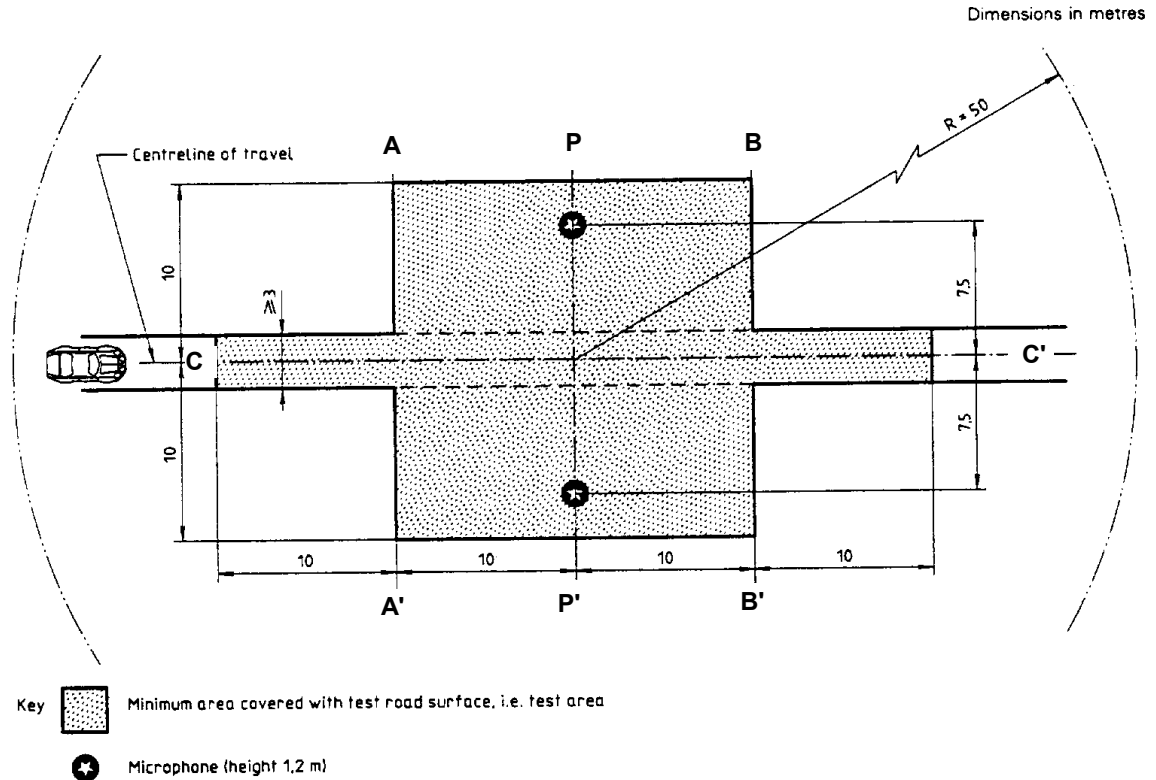

NOTE — There shall be no large acoustically reflective objects within this radius.

**Figure 1:** Minimum requirement for test surface area. The shaded part is called "Test Area".

### 3.2. Design and preparation of the surface

#### 3.2.1. Basic design requirements

The test surface shall meet four design requirements:

- 3.2.1.1. It shall be a dense asphalt concrete.
- 3.2.1.2. The maximum chipping size shall be 8 mm (tolerances allow from 6.3 to 10 mm).
- 3.2.1.3. The thickness of the wearing course shall be  $\geq 30$  mm.
- 3.2.1.4. The binder shall be a straight penetration grade bitumen without modification.

3.2.2. Design guidelines

As a guide to the surface constructor, an aggregate grading curve which will give desired characteristics is shown in Figure 2. In addition, Table 1 gives some guidelines in order to obtain the desired texture and durability. The grading curve fits the following formula:

$$P (\% \text{ passing}) = 100 \cdot (d/d_{\max})^{1/2}$$

where:

- d = square mesh sieve size, in mm
- d<sub>max</sub> = 8 mm for the mean curve
- d<sub>max</sub> = 10 mm for the lower tolerance curve
- d<sub>max</sub> = 6.3 mm for the upper tolerance curve

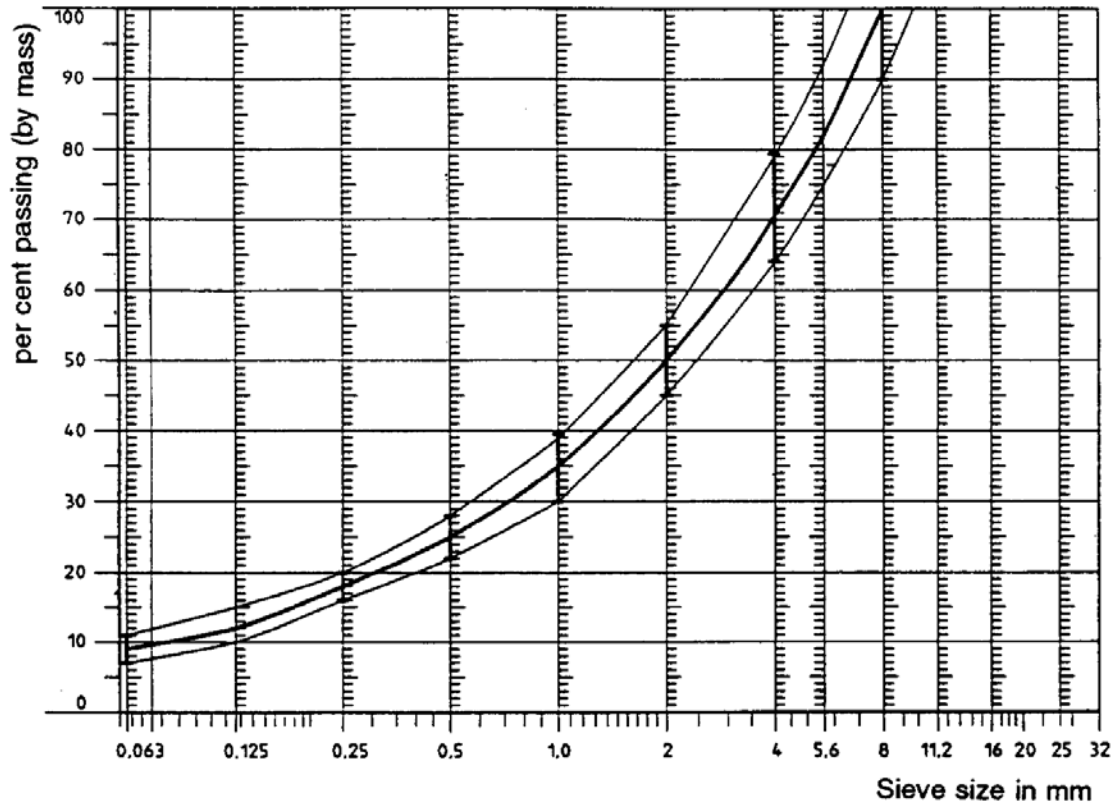

Figure 2: Grading curve of the aggregate in the **stone mix**, with tolerances.

In addition to the above, the following recommendations are given:

- (a) The sand fraction (0.063 mm < square mesh sieve size < 2 mm) shall include no more than 55 per cent natural sand and at least 45 per cent crushed sand;
- (b) The base and sub-base shall ensure a good stability and evenness, according to best road construction practice;
- (c) The chippings shall be crushed (100 per cent crushed faces) and of a material with a high resistance to crushing;
- (d) The chippings used in the mix shall be washed;
- (e) No extra chippings shall be added onto the surface;
- (f) The binder hardness expressed as PEN value shall be 40-60, 60-80 or even 80-100 depending on the climatic conditions of the country. The rule is that as hard a binder as possible shall be used, provided this is consistent with common practice;
- (g) The temperature of the mix before rolling shall be chosen so as to achieve by subsequent rolling the required voids content. In order to increase the probability of satisfying the specifications of paragraphs 2.1. to 2.4. above, the compactness shall be studied not only by an appropriate choice of mixing temperature, but also by an appropriate number of passings and by the choice of compacting vehicle.

Table 1: Design guidelines

	Target values		Tolerances
	By total mass of mix	By mass of the aggregate	
Mass of stones, square mesh sieve (SM) > 2 mm	47.6 %	50.5 %	± 5
Mass of sand 0.063 < SM < 2 mm	38.0 %	40.2 %	± 5
Mass of filler SM < 0.063 mm	8.8 %	9.3 %	± 2
Mass of binder (bitumen)	5.8 %	N.A.	± 0.5
Max. chipping size		8 mm	6.3 - 10
Binder hardness	(see para. 3.2.2. (f))		
Polished stone value (PSV)		> 50	
Compactness, relative to Marshall compactness		98 %	

4. Test method

4.1. Measurement of the residual voids content

For the purpose of this measurement, cores have to be taken from the track in at least four different positions which are equally distributed in the test area between lines AA' and BB' (see Figure 1). In order to avoid inhomogeneity and unevenness in the wheel tracks, cores should not be taken in wheel tracks themselves, but close to them. Two cores (minimum) should be taken close to the wheel tracks and one core (minimum) should be taken approximately midway between the wheel tracks and each microphone location.

If there is a suspicion that the condition of homogeneity is not met (see paragraph 2.4.), cores shall be taken from more locations within the test area.

The residual voids content has to be determined for each core, then the average value from all cores shall be calculated and compared with the requirement of paragraph 2.1. In addition, no single core shall have a voids value which is higher than 10 per cent. The test surface constructor is reminded of the problem which may arise when the test area is heated by pipes or electrical wires and cores must be taken from this area. Such installations must be carefully planned with respect to future core drilling locations. It is recommended to leave a few locations of size approximately 200 x 300 mm where there are no wires/pipes or where the latter are located deep enough in order not to be damaged by cores taken from the surface layer.

4.2. Sound absorption coefficient

The sound absorption coefficient (normal incidence) shall be measured by the impedance tube method using the procedure specified in ISO 10534-1: "Acoustics - Determination of sound absorption coefficient and impedance by a tube method." 2/

Regarding test specimens, the same requirements shall be followed as regarding the residual voids content (see paragraph 4.1.). The sound absorption shall be measured in the range between 400 Hz and 800 Hz and in the range between 800 Hz and 1,600 Hz (at least at the centre frequencies of third octave bands) and the maximum values shall be identified for both of these frequency ranges. Then these values, for all test cores, shall be averaged to constitute the final result.

---

2/ To be published.

#### 4.3. Volumetric macro texture measurement

For the purpose of this standard, texture depth measurements shall be made on at least 10 positions evenly spaced along the wheel tracks of the test strip and the average value taken to compare with the specified minimum texture depth. See the draft ISO 10844:1994 for description of the procedure.

#### 5. Stability in time and maintenance

##### 5.1. Age influence

In common with any other surfaces, it is expected that the tyre/road sound level measured on the test surface may increase slightly during the first 6-12 months after construction.

The surface will achieve its required characteristics not earlier than four weeks after construction. The influence of age on the sound from trucks is generally less than that from cars.

The stability over time is determined mainly by the polishing and compaction by vehicles driving on the surface. It shall be periodically checked as stated in paragraph 2.5.

##### 5.2. Maintenance of the surface

Loose debris or dust which could significantly reduce the effective texture depth must be removed from the surface. In countries with winter climates, salt is sometimes used for de-icing. Salt may alter the surface temporarily or even permanently in such a way as to increase sound and is therefore not recommended.

##### 5.3. Repaving the test area

If it is necessary to repave the test track, it is usually unnecessary to repave more than the test strip (of 3 m width in Figure 1) where vehicles are driving, provided the test area outside the strip met the requirement of residual voids content or sound absorption when it was measured.

#### 6. Documentation of the test surface and of tests performed on it

##### 6.1. Documentation of the test surface

The following data shall be given in a document describing the test surface:

###### 6.1.1. The location of the test track.

###### 6.1.2. Type of binder, binder hardness, type of aggregate, maximum theoretical density of the concrete ( $D_R$ ), thickness of the wearing course and grading curve determined from cores from the test track.

- 6.1.3. Method of compaction (e.g. type of roller, roller mass, number of passes).
- 6.1.4. Temperature of the mix, temperature of the ambient air and wind speed during laying of the surface.
- 6.1.5. Date when the surface was laid and contractor.
- 6.1.6. All or at least the latest test result, including:
  - 6.1.6.1. The residual voids content of each core.
  - 6.1.6.2. The locations in the test area from where the cores for voids measurements have been taken.
  - 6.1.6.3. The sound absorption coefficient of each core (if measured). Specify the results both for each core and each frequency range as well as the overall average.
  - 6.1.6.4. The locations in the test area from where the cores for absorption measurement have been taken.
  - 6.1.6.5. Texture depth, including the number of tests and standard deviation.
  - 6.1.6.6. The institution responsible for tests according to paragraphs 6.1.6.1. and 6.1.6.2. and the type of equipment used.
  - 6.1.6.7. Date of the test(s) and date when the cores were taken from the test track.
- 6.2. Documentation of vehicle sound tests conducted on the surface

In the document describing the vehicle sound test(s) it shall be stated whether all the requirements of this standard were fulfilled or not. Reference shall be given to a document according to paragraph 6.1. describing the results which verify this.

---



Annex 9

## SYMBOLS USED

Symbol	Unit	Explanation
$v_{AA'}$	km/h	vehicle speed at the approach of line AA'
$v_{BB'}$	km/h	vehicle speed at the end of the test track
$v_{test}$	km/h	speed at microphone position
$n_{AA'}$	1/min	engine rotation speed of the vehicle, when the reference point passes line AA'
$n_{BB'}$	1/min	engine rotation speed of the vehicle, when the reference point passes line BB'
S	1/min	rated engine speed in rpm, synonymous with the engine speed at maximum power
$P_n$	kW	rated engine power (ISO 1585:1992)
$m_t$	kg	test mass of the vehicle
$m_{kerb}$	kg	kerb mass of the vehicle
$m_{ref}$	kg	kerb mass + 75 kg for the driver
$l_{veh}$	m	length of vehicle
$L_{wot\ rep}$	dB	reported vehicle sound at wide open throttle
$L_{wot}$	dB	vehicle sound at wide open throttle
$L_{crs\ rep}$	dB	reported vehicle sound at constant speed test
$L_{crs}$	dB	vehicle sound at constant speed test
$a_{wot\ ref}$	$m/s^2$	reference acceleration rate for the wide open throttle test
$a_{wot\ i}$	$m/s^2$	acceleration at wide open throttle in gear i
$a_{wot\ i+1}$	$m/s^2$	acceleration at wide open throttle in gear i+1
$a_{wot\ test}$	$m/s^2$	acceleration at wide open throttle in single gear test cases
$a_{urban}$	$m/s^2$	target acceleration respective urban traffic acceleration
gear i		the first of two gear ratio for use in the vehicle test
gear i+1		the second of two gear ratio with an engine speed lower than gear ratio i
$k_p$		partial power factor
k		gear weighting factor
$c_v$		correction value for background sound
$\Delta L$		difference between the sound level measured for the vehicle and the background sound level
PMR		power to mass ratio to be used for calculation

Annex 10

**[ADDITIONAL SOUND EMISSION PROVISIONS**

**During development of the provisions for off cycle emissions the technical provisions of ECE Regulation No. 51, 02 series of amendments shall be fulfilled.]**

---

Annex 11

EXAMPLE FOR MEASUREMENT PROCEDURE FOR VEHICLES OF CATEGORY M<sub>1</sub>, N<sub>1</sub>

