

Distr.  
GENERAL

TRANS/WP.29/GRSP/2001/16/Rev.1  
28 February 2002

Original: ENGLISH

ECONOMIC COMMISSION FOR EUROPE

INLAND TRANSPORT COMMITTEE

World Forum for Harmonisation of Vehicle Regulations (WP.29)

Working Party on Passive Safety (GRSP)  
(Thirty-first session, 13-17 May 2002,  
agenda item 2.)

PROPOSAL FOR DRAFT 04 SERIES OF AMENDMENTS TO REGULATION No. 44  
(Child restraints)

Revision 1

Transmitted by the Expert from France

Note: The text reproduced below was prepared by the expert from France in order to introduce into Regulation No. 44 the new anchorage system standard for child restraint systems (CRS) **groups 0, 0+, 1 and 1+** prepared by the International Organisation for Standardisation (ISO). It is based on a document distributed without a symbol (informal document No. 15) during the thirtieth session (TRANS/WP29/GRSP/50, para. 45).

The text is presented as follows:

- (1) "ISOFIX" is used as a qualified adjective in order to simplify the modification redaction and to allow child restraint system users to be able to identify ISOFIX restraints without any doubt,
- (2) words added from the original text of Regulation No. 44 are written in bold types,
- (3) words added (or removed) to document TRANS/WP.29/GRSP/2001/16 are underlined (or crossed out).

---

Note: This document is distributed to the Experts on Passive Safety only.

GE.02-

Insert a new paragraph 2.1.1.4., to read:

"2.1.1.4. Group I+ for children of mass from 15 kg to 22 kg."

Paragraphs 2.1.1.4. and 2.1.1.5.1. (former), renumber as paragraphs 2.1.1.5. and 2.1.1.6.

Insert a new paragraph 2.1.1.7., to read:

"2.1.1.7 ISOFIX Child restraint systems fall into 5 fixtures described in Regulation No. 16 annex 17, appendix 2 :

- ISO 1: Full Height Forward Facing toddler CRS
- ISO 2: Reduced Height Forward Facing toddler CRS
- ISO 3: Full Size Rearward Facing toddler CRS
- ISO 4: Reduced Size Rearward Facing toddler CRS
- ISO 5: Rearward Facing infant CRS

Mass group	Fixture
0 - up to 10 kg	ISO 5
0+ - up to 13 kg	ISO 3
	ISO 4
	ISO 5
1 - 9 to 18 kg	ISO 1
	ISO 2
	ISO 3
	ISO 4
1+ - 15 to 22 kg	ISO 1
	ISO 2

"

Paragraph 2.1.2.1., amend to read:

"2.1.2.1. A "universal" category for use as specified in paragraphs 6.1.1. and 6.1.3.1. on most vehicle seat positions, and in particular those which have been assessed according to ~~annex 13~~ appendix 2 of the Consolidated Resolution on the Construction of Vehicles (R.E.3) \*/ Regulation No. 16 - as being compatible with such a category of child restraint."

Insert new paragraphs 2.14.2. to 2.14.4., to read:

"2.14.2. ISOFIX low anchorage means one 6 mm diameter rigid round horizontal bar, extending from vehicle or seat structure to accept and restrain an ISOFIX child restraint system with ISOFIX attachments.

2.14.3. ISOFIX anchorage system means a system including two ISOFIX anchorages which is designed for attaching an ISOFIX child restraint system."

2.14.4. "ISOFIX top tether anchorage" means a feature, such as a bar, located in a defined zone, designed to accept an ISOFIX tether strap connector and transfer its restraint forces to the vehicle structure."

Insert new paragraphs 2.28. to 2.35., to read:

- "2.28. ISOFIX attachment means one of the two connections, fulfilling the requirement of paragraph 6.3.2. of this Regulation, extending from the ISOFIX child restraint system structure, and compatible with an ISOFIX low anchorage.
- 2.29. ISOFIX child restraint system means a child restraint system which has to be attached to an ISOFIX anchorage system.
- 2.30. Seat bight means the area close to the intersection of the surfaces of the vehicle seat cushion and the seat back.
- 2.31. Vehicle seat fixture (VSF) means a fixture, complying to dimensions shown in figures 1 and 2 of annex 7 appendix 2 of Regulation No. 16, used by a child restraint manufacturer to determine the appropriate dimensions of an ISOFIX child restraint system and the location of its ISOFIX attachments .
- 2.32. "ISOFIX top tether connector" means a device intended to be attached to an ISOFIX top tether anchorage.
- 2.33. "ISOFIX top tether hook" means a ISOFIX top tether connector typically used to attach a ISOFIX top tether strap to a ISOFIX top tether anchorage as defined in figure 3 of Regulation No. 14.
- 2.34. "ISOFIX top tether strap" means a webbing strap which extends from the top of an ISOFIX child restraint system to the ISOFIX top tether anchorage, and which is equipped with an adjustment device, a tension-relieving device, and a top tether connector.
- 2.35. " ISOFIX Top tether attachment" is a device to secure the ISOFIX top tether hook to the vehicle structure."

Paragraph 5.4.2.2., amend to read:

- "5.4.2.2. The mass range for which the child restraint has been designed, namely: 0-10 kg; 0-13 kg; 9-18 kg; 15-22 kg; 15-25 kg; 22-36 kg; less than 18 kg; 9-25 kg; 15-36 kg; less than 25 kg; 9-36 kg, less than 36 kg."

Paragraph 6.1.3., amend to read:

- "6.1.3. According to the category which it belongs to, the child restraint shall be secured to the vehicle structure or to the seat structure by means of vehicle safety belt and/or ISOFIX anchorage systems and/or ISOFIX top tether anchorage and/or additional anchorage meeting the requirement of Regulation No. 44.

GROUPS / CATEGORIES TABLE

Group \ Category		Universal		Semi-universal		Restricted		Specific Vehicle	
		CRS	ISOFIX CRS	CRS	ISOFIX CRS	CRS	ISOFIX CRS	CRS	ISOFIX CRS
0	Carry-cot	A	NA	A	NA	A	NA	A	A
	Rearward facing	A	NA	A	A	A	A	A	A
0+	Rearward facing	A	NA	A	A	A	A	A	A
I	Rearward facing	A	NA	A	A	A	A	A	A
	Forward facing (integral)	A	A	A	A	A	A	A	A
	Forward facing (non integral)	A	NA	A	A	A	NA	A	A
I+	Forward facing (integral)	A	A	A	A	A	A	A	A
	Forward facing (non integral)	A	NA	A	A	A	NA	A	A
II	Forward facing (integral)	A	NA	A	NA	A	NA	A	A
	Forward facing (non integral)	A	NA	A	NA	A	NA	A	A
III	Forward facing (integral)	A	NA	A	NA	A	NA	A	A
	Forward facing (non integral)	A	NA	A	NA	A	NA	A	A

With:

CRS: Child restraint system

A: Applicable

NA: Non Applicable"

Paragraphs 6.1.3.1. and 6.1.3.2., amend to read:

"6.1.3.1. For the "universal" and "restricted" categories, by means of an adult safety-belt (with or without a retractor) meeting the requirements of Regulation No. 16 (or equivalent) fitted to anchorages meeting the requirements of Regulation No. 14 (or equivalent) ~~and~~ or by means of ISOFIX attachments and ISOFIX top tether attachments meeting the requirements of this Regulation fitted to ISOFIX anchorages and ISOFIX top tether anchorage meeting the requirements of Regulation No. 14.

6.1.3.2. For the "semi-universal" category: by means of lower anchorages prescribed in Regulation No. 14 and additional anchorages meeting the recommendation of this Regulation and / or by means of ISOFIX attachments and/or ISOFIX top tether attachments meeting the requirements of this Regulation fitted to ISOFIX anchorages and/or ISOFIX top tether anchorage meeting the requirements of Regulation No. 14."

Paragraph 6.1.6., the reference to document "TRANS/WP.29/78/Rev.1, paragraph 1.42", should read "TRANS/WP.29/78/Rev.1, paragraph 1.20."

Paragraphs 6.1.8. and 6.1.9., amend to read:

"6.1.8. In the case of a child restraint system of the "universal" category, the main load-bearing point, if any, between the child restraint and the adult safety-belt shall not be less than 150 mm from the Cr axis when measured with the child restraint on the dynamic test bench."

"6.1.9. If the adult belt is required to secure a "universal" category child restraint, its maximum length to be used on the dynamic test bench is defined in annex 13 to this Regulation.

To check compliance with this requirement, ..."

Paragraph 6.2.1.4., amend to read:

"6.2.1.4. The group 0, 0+, I and I+ restraint system ..."

Paragraph 6.2.1.5., amend to read:

"... forward-facing group I or I+ restraints incorporating ... the pelvis in either the 9 kg or the 15 kg or the 22 kg dummy."

Paragraph 6.2.2., amend to read:

"6.2.2. For groups I, I+, II and III, all restraint devices ..."

Paragraph 6.2.7., amend to read:

"6.2.7. Where a child restraint intended for group I, group I+, group II and groups I, I and II, I and I+ and II ..."

Paragraph 6.2.9., amend to read:

"6.2.9. For devices intended for use in Group I or I+ it must not be possible ..."

Insert new paragraphs 6.3. to 6.3.4., to read:

"6.3. ISOFIX restraint specifications

6.3.1. Dimensions

The maximum lateral, downward, and rearward dimensions for the ISOFIX child restraint system and the locations of the ISOFIX anchorages with which its attachments must engage are defined for the ISOFIX child restraint system manufacturer by the Vehicle Seat Fixture (VSF) defined by paragraph 2.31. of this Regulation.

6.3.2. ISOFIX Attachments

6.3.2.1. Type

ISOFIX Attachments to anchorages may be according to examples shown in Figure 0c, or other appropriate designs that are part of a rigid mechanism having provision for adjustment, the nature of which is determined by the ISOFIX child restraint system manufacturer.

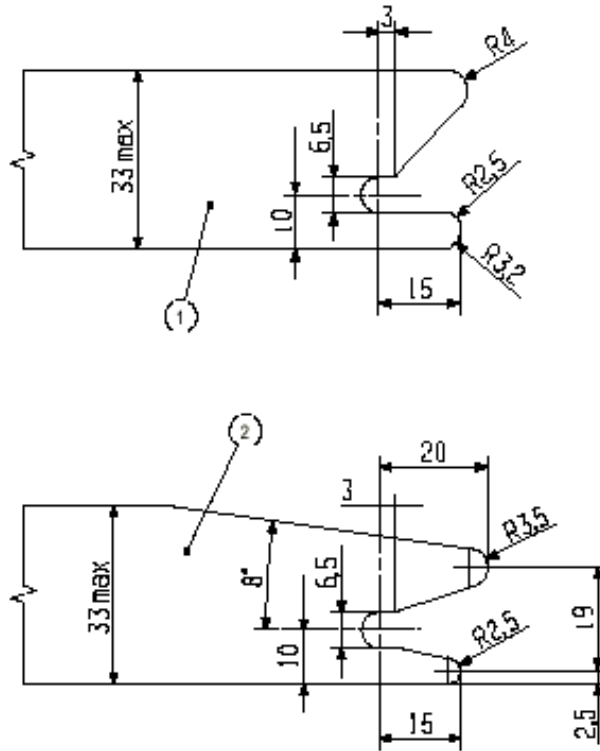

Dimensions in mm

Figure 0c

**Key**

- 1 ISOFIX CRS connector - example 1
- 2 ISOFIX CRS connector - example 2



**6.3.3.3.2. Minimum force indicator**

The ISOFIX top tether strap assembly should preferably be equipped with a device that will indicate that a force of 50 N has been introduced to the strap. The device may be part of adjustment and tension release device.

**6.3.3.3.3. Dimensions**

Engagement dimensions for ISOFIX top tether hooks are shown in Figure 0e.

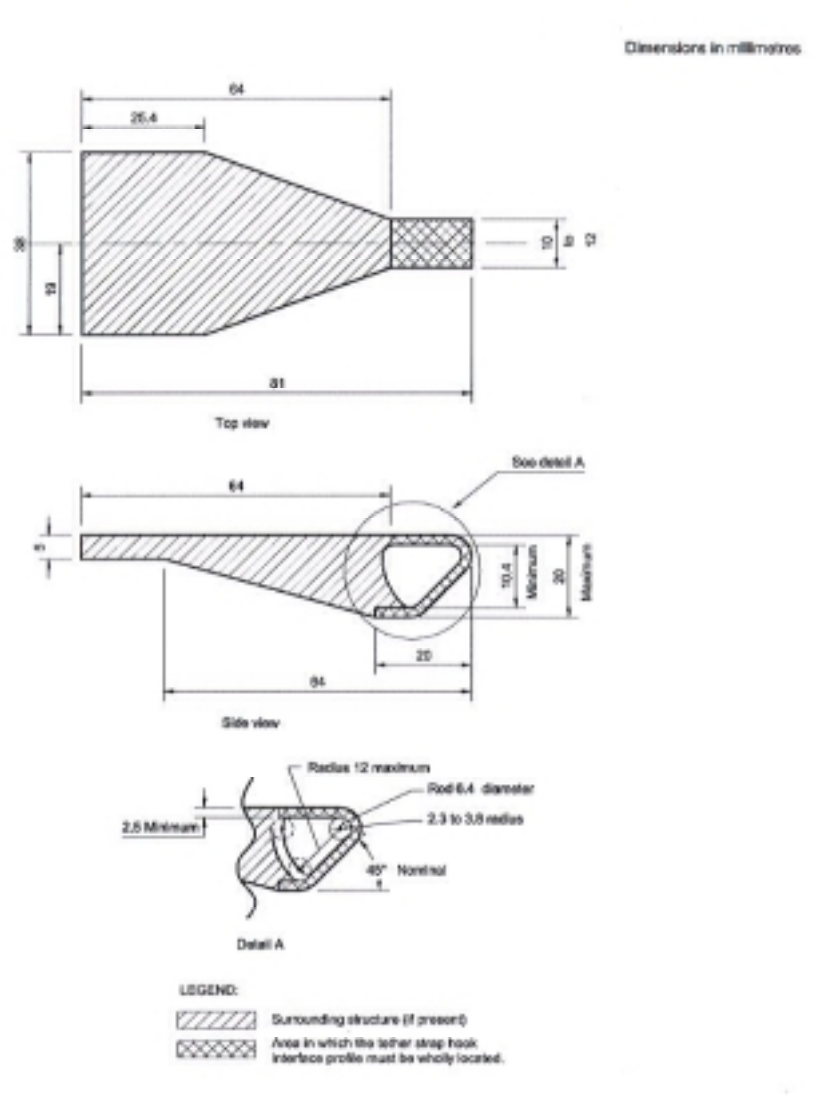

**Figure 0e: ISOFIX Top tether connector (hook type) dimensions**



**6.3.4. Adjustment provisions**

The ISOFIX attachments, or the ISOFIX child restraint system itself, shall be adjustable to accommodate the range of ISOFIX anchorage locations described in Regulation No. 14."

Paragraph 7.2.1.9.3., amend to read:

"**7.2.1.9.3.** A harness buckle of mass group I or I+ and higher shall withstand 10,000 N."

Paragraph 7.2.4.1.1., amend to read:

"... for groups 0, 0+ and I, and 38 mm for groups I+, II and III. These dimensions shall be measured ..."

Paragraph 7.2.4.3.2., amend to read:

"... the groups 0, 0+ and I, 5 kN for those of groups I+ and II and 7.2 kN for those of group III."

Insert a new paragraph 7.2.6., to read:

"**7.2.6.** ISOFIX attachment specifications

"ISOFIX attachments" and latching indicators shall be capable of withstanding repeated operations and shall, before the dynamic test prescribed in paragraph 8.1.3., undergo a test comprising [2000 ± 5] opening and closing cycles under normal conditions of use."

[NB: the above proposal is very close to paragraph 7.2.1.7. relative to buckle dynamic test.]

Paragraph 8.1.3.1.1.4.3., amend to read:

"**8.1.3.1.1.4.3.** The displacement of the manikin's head in the vertical and horizontal planes for groups I, I+, II and III and for group 0 and 0+ the displacement of the manikin without considering its limb:"

Insert a new paragraph 8.1.3.7.4., to read:

"**8.1.3.7.4.** Group I+ device: Tests performed with using a manikin of mass 15 kg and 22 kg respectively"

Paragraphs 8.1.3.7.4. to 8.1.3.7.7. (former), renumber as paragraphs 8.1.3.7.5. to 8.1.3.7.8.

Insert a new paragraph 8.1.3.7.9., to read:

"**8.1.3.7.9** If the ISOFIX child restraint system must use a top tether, one test shall be carried out with the smallest dummy with the shorter distance of the top tether. A second test shall be carried out with the heavier dummy with the longer distance of the top tether. Adjust the top tether to achieve a tension load of 50 ± 5 N."

Insert a new paragraph 14.2.11., to read:

"14.2.11. For an "ISOFIX child restraint system" the following label shall be clearly visible at the point of sale without removing the packing:

**NOTICE**

1. This is an ISOFIX CHILD RESTRAINT SYSTEM. It is approved to Regulation No. 44-04 series of amendments for general use in vehicles fitted with ISOFIX anchorages systems.

2. It will fit vehicles with positions approved as ISOFIX positions (as detailed in the vehicle handbook), depending on the category of the seat and of the fixture.

"

Insert a new paragraph 14.2.12., to read:

"14.2.12. For an ISOFIX child restraint system, the weight groups and the fixture for which the device is intended shall be indicated."

Paragraph 14.3.1., amend to read :

"14.3.1. The weight groups **and the fixture** for which the device is intended"

Insert a new paragraph 14.3.14., to read:

"14.3.14. For an "ISOFIX child restraint system", the instruction for use must be given to read the car manufacturer book."

Annex 6, appendix 3,

Paragraph 1., amend to read:

"1. The anchorages shall be positioned as shown in the figures 1, 2 and 3 below."

Paragraphs 2.1. and 2.2., amend to read:

"2.1. For child restraint **using** lap belts, points A and B;

2.2. For child restraint **using** lap and diagonal belts, points A, BO and C."

Insert a new paragraph 2.3., to read:

**"2.3. For child restraints using ISOFIX attachment, points H<sub>1</sub> and H<sub>2</sub>."**

Paragraphs 3. and 4., amend to read:

"3. Anchorages A, B **and/or** H<sub>1</sub> H<sub>2</sub> and D shall be used (.... no change....) upper anchorage.

4. Anchorages A, B **and/or** H<sub>1</sub> H<sub>2</sub>, E and F shall be used (... no change...) upper anchorages."

Paragraph 8., amend to read:

"8. For testing of child restraints in the "universal" and "restricted" categories, a standard retractor belt, as specified in annex 13, and/or an ISOFIX anchorages system and ISOFIX top tether anchorage, shall be fitted to the test seat."

Insert a new paragraph 9., to read:

**"9. For testing of child restraints with top tether, the anchorage G<sub>1</sub> or G<sub>2</sub> shall be used."**

Insert a new figure 3, to read:

"

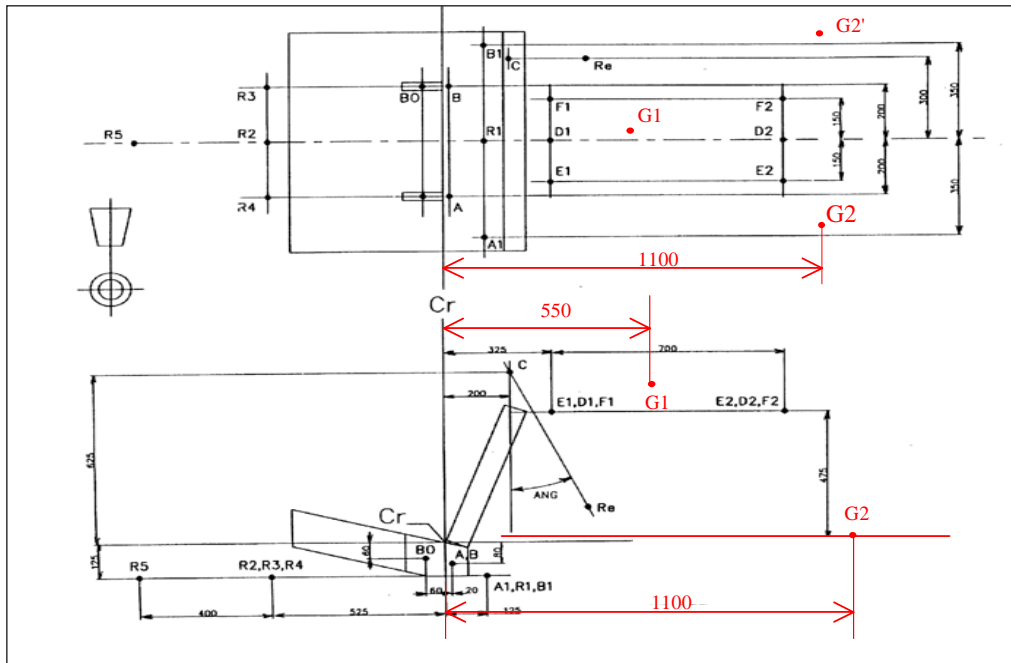



Annex 11 footnote 1/, amend to read :

"1/ See text of ~~paragraph 1.13 and of annex 10 of the Consolidated Resolution on the Construction of Vehicles (R.E.3) (TRANS/ SC1/ WP29/ 78) Regulation No. 16.~~

Annex 21,

The figure, amend to read:

"

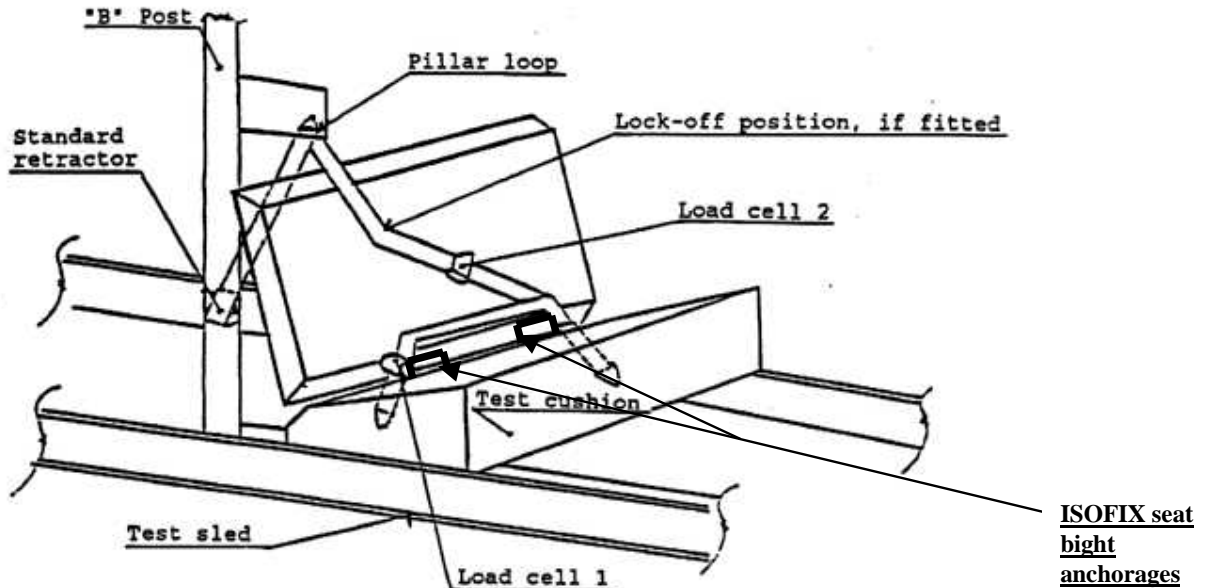

"

Paragraph 1.2.3., amend to read:

"1.2.3. Extract all webbing from the retractor spool and allow the tension in the belt between the retractor and pillar loop to drop to the retractor tension. The spool shall be locked before the dynamic test."

Insert a new paragraph 1.3., to read:

"1.3. ISOFIX attachment

For an ISOFIX child restraint system with adjustable position seat bight ISOFIX anchorages. Attach the unladen ISOFIX child restraint system onto the seat bight anchorages, H1 and H2 in the appropriate test position. Allow the ISOFIX child restraint latches to pull the unladen ISOFIX child restraint system towards the seat bight. Apply an additional force of  $135 \pm 15$  N in the horizontal reference plane of the ISOFIX child restraint system in the direction of the seat bight to overcome frictional forces between the ISOFIX child restraint system and the seat cushion, assisting the self-tensioning effects of the latch mechanism. If needed, adjust the top tether to achieve a tension load of  $50 \pm 5$  N (1/). Place appropriate test dummy in child restraint when the ISOFIX child restraint system has been so adjusted.

**Note 1/:** In the case of restraints fitted with devices intended to increase the adult safety belt **the top tether tension**, the test method shall be:  
Install the **ISOFIX** child restraint system as required in this annex and then apply the tensioner device as stated in the manufacturers instructions. If the device cannot be applied due to excess tension then it is deemed to be an unacceptable device."

Note 1, amend to read:

- "1. Installation is conducted after fitting the manikin into the restraint **for paragraphs 1.1. and 1.2.**"
-