

Distr.
GENERAL

TRANS/WP.29/GRSP/2000/9/Add.1
8 February 2001

Original: ENGLISH

ECONOMIC COMMISSION FOR EUROPE

INLAND TRANSPORT COMMITTEE

World Forum for Harmonization of Vehicles Regulations (WP.29)

Working Party on Passive Safety (GRSP)
(Twenty-ninth session, 7-11 May 2001,
agenda item 2.2.)

PROPOSAL FOR DRAFT AMENDMENTS TO REGULATION No. 14
(Safety-belt anchorages)

Addendum 1

Transmitted by the Expert from the International Organization of
Motor Vehicles Manufacturers (OICA)

Note: The text reproduced below was prepared by the expert from OICA in order
to update his proposal.

Note: This document is distributed to the Experts on Passive Safety only.

GE.01-

Paragraph 4.2.4., amend to read:

"..... in paragraphs 4.2.1. to 4.2.3. of this Regulation"

Paragraph 4.3.2., amend to read:

"..... plane of the vehicle. A pre-load of $1,000\text{ N} \pm 250\text{ N}$ may be applied; this pre-load will be included in the total test load."

Paragraph 4.3.3., amend to read:

"..... as rapidly as possible: within a maximum of 3 seconds. The belt anchorages must withstand"

Annex 3, amend to read:

"Annex 3

(All dimensions are in mm)

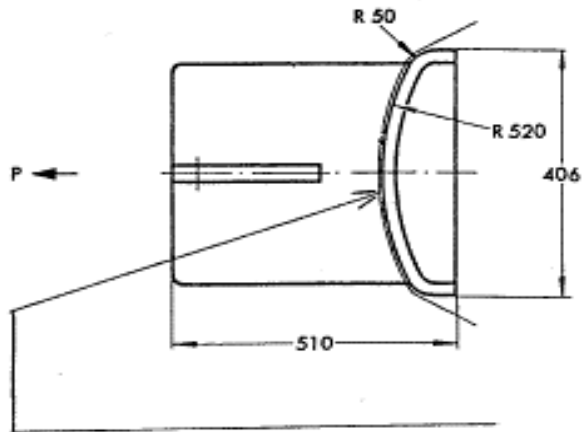

Cloth-covered Loan, thickness: 25

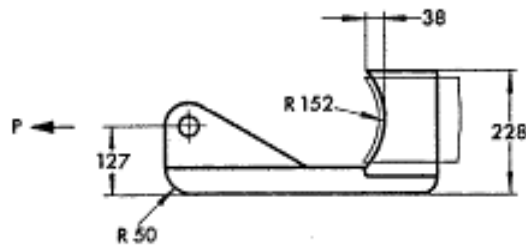

Figure 1

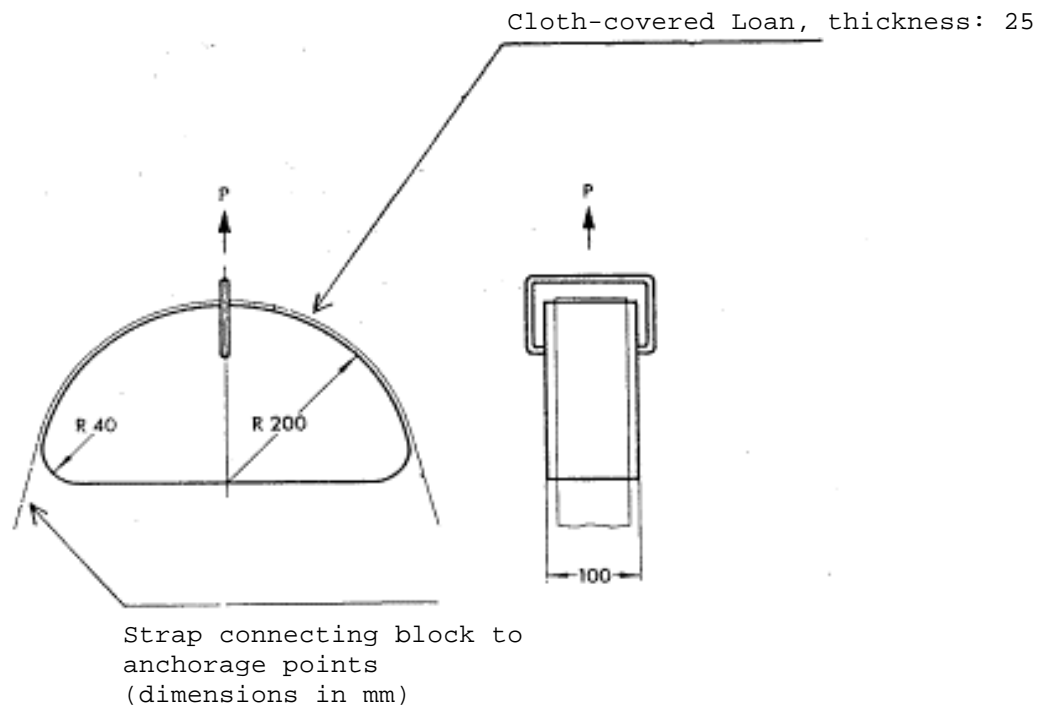

Figure 2"
