

# Near-Zero Methane Emissions Coal Mining in China

## The Duerping story



David Creedy & Clark Talkington, Sindicatum Carbon Capital

5<sup>th</sup> Session of the UNECE Ad Hoc Group of Experts on Coal Mine  
Methane  
Geneva, Switzerland  
13 October 2007

## Duerping Mine

- Owned by Shanxi Coking Coal Ltd
- Xishan Coal Field near Taiyuan City
- 1,600m above sea level
- Metallurgical coal mine
- Production capacity = 5 Mtpa
- 700 Mt reserves
- 50 year life
- Relative emissions = 17.7 m<sup>3</sup>/t (567 ft<sup>3</sup>/st)
- CH<sub>4</sub> emissions increasing as mine goes deeper and production increases
- Drainage system
  - in place prior to project development
  - CH<sub>4</sub> concentrations: 25-30%
  - Efficiency = 15%
- No CMM utilization

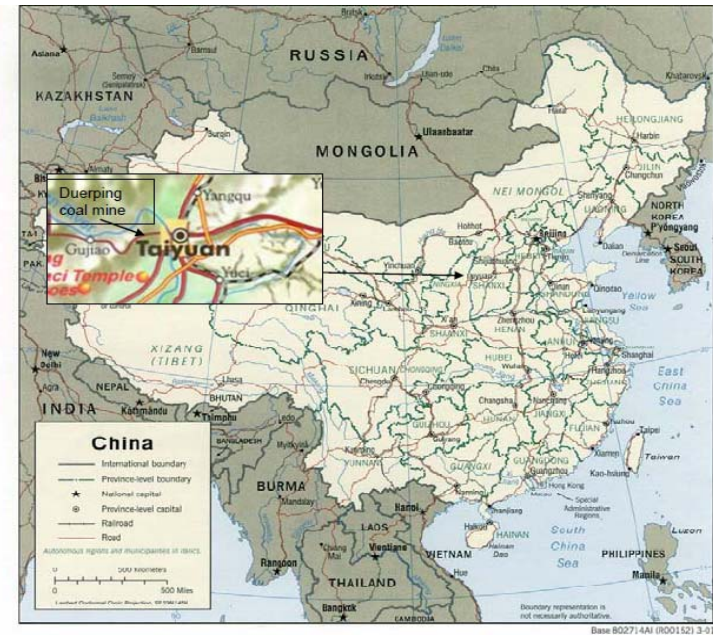

## The Duerping project: a FIRST in China to introduce:

- A “live” mine connection to a modern co-generation plant without use of a large, land consuming and costly gas holder
- High-efficiency, modern CMM fuelled generators at a remote 1600m altitude site
- CMM flaring to abate methane that cannot be utilised in the power generators
- Full time international mining team collaborating with mines to raise gas quality standards to ensure safe and optimum project performance
- A potential near-zero methane emissions coal mining concept demonstration project
- Remote CDM and engineering telemetry, data collection and processing system (based on Formac’s Telgas system)

# Duerping gas balance

## DUERPING MINE BALANCE to 17-03-09

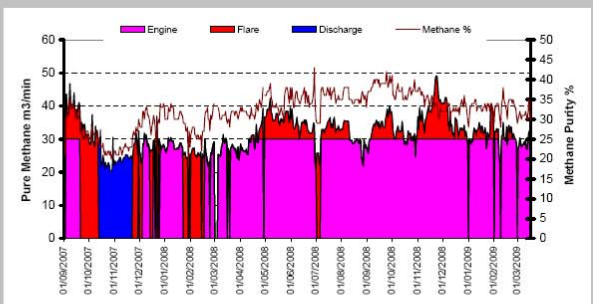
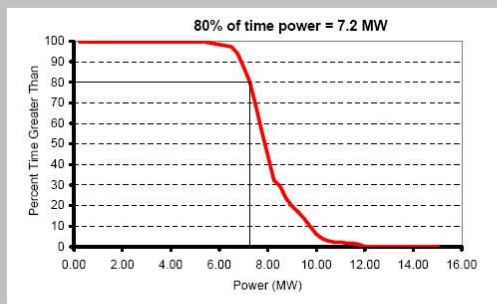
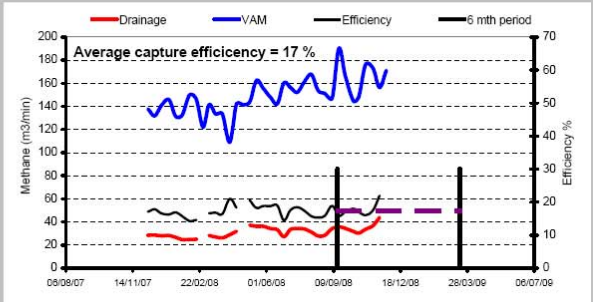
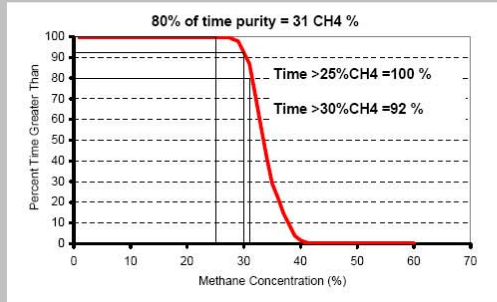
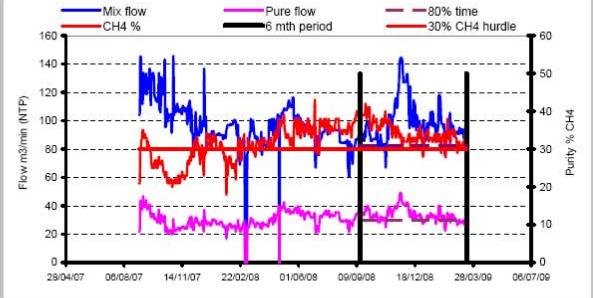
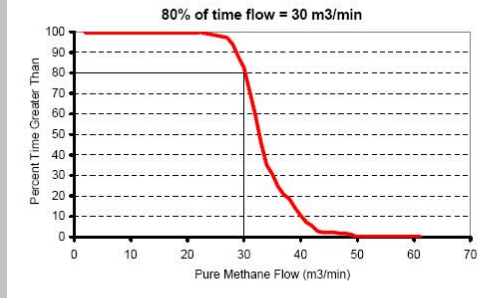

**DUERPING MINE BALANCE to 17-03-09**

Last six months  
 80% of time flow = 30 m3/min  
 80% of time purity = 31 CH4 %  
 Time >30%CH4 = 92 %  
 Time >25%CH4 = 100 %  
 80% of time power = 7.2 MW

IF 80% power installed, then  
 Actual avail power = 7 MW  
 Flare volume = 6008 m3/hr

	m3 CH4	%
Base line	-	0.0
Engines	7,674,484	86.7
Flare	1,181,972	13.3
Discharge	-	0.0
<b>Total</b>	<b>8,856,456</b>	<b>100</b>

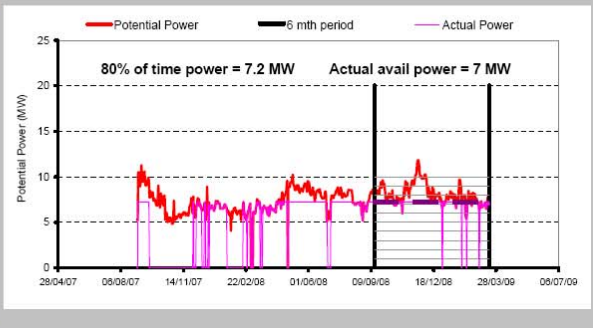

## Increase gas availability for power generation

### 1. Enhance methane purity

- Improve borehole sealing (2-stage)
- Comprehensive monitoring
- Regulate boreholes
- Regulate suction

### 2. Raise gas capture

- Increase orifice-plate size
- Improved borehole design and pattern
- Consider floor boreholes
- Controlled extraction from sealed areas
- Introduce alternative capture technologies
- Enhanced gas management

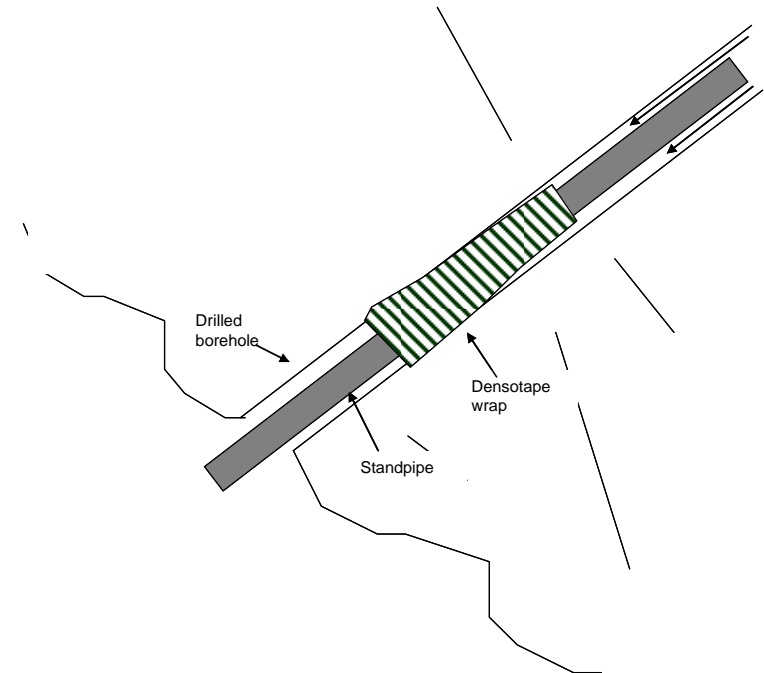

## Determining optimum generation capacity

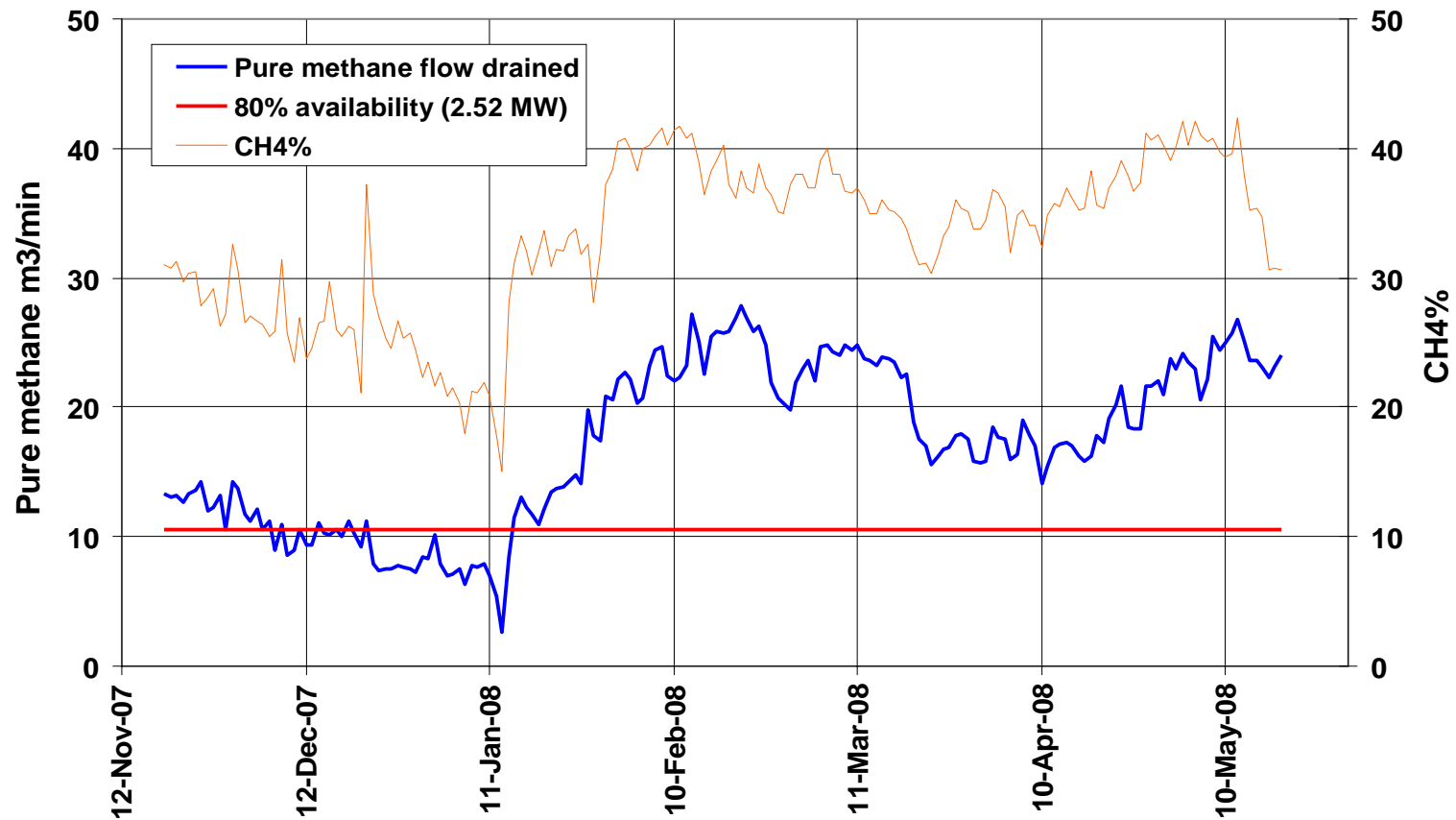

## Completed first phase – EB registered 6 March 2009



# Operational performance monitoring

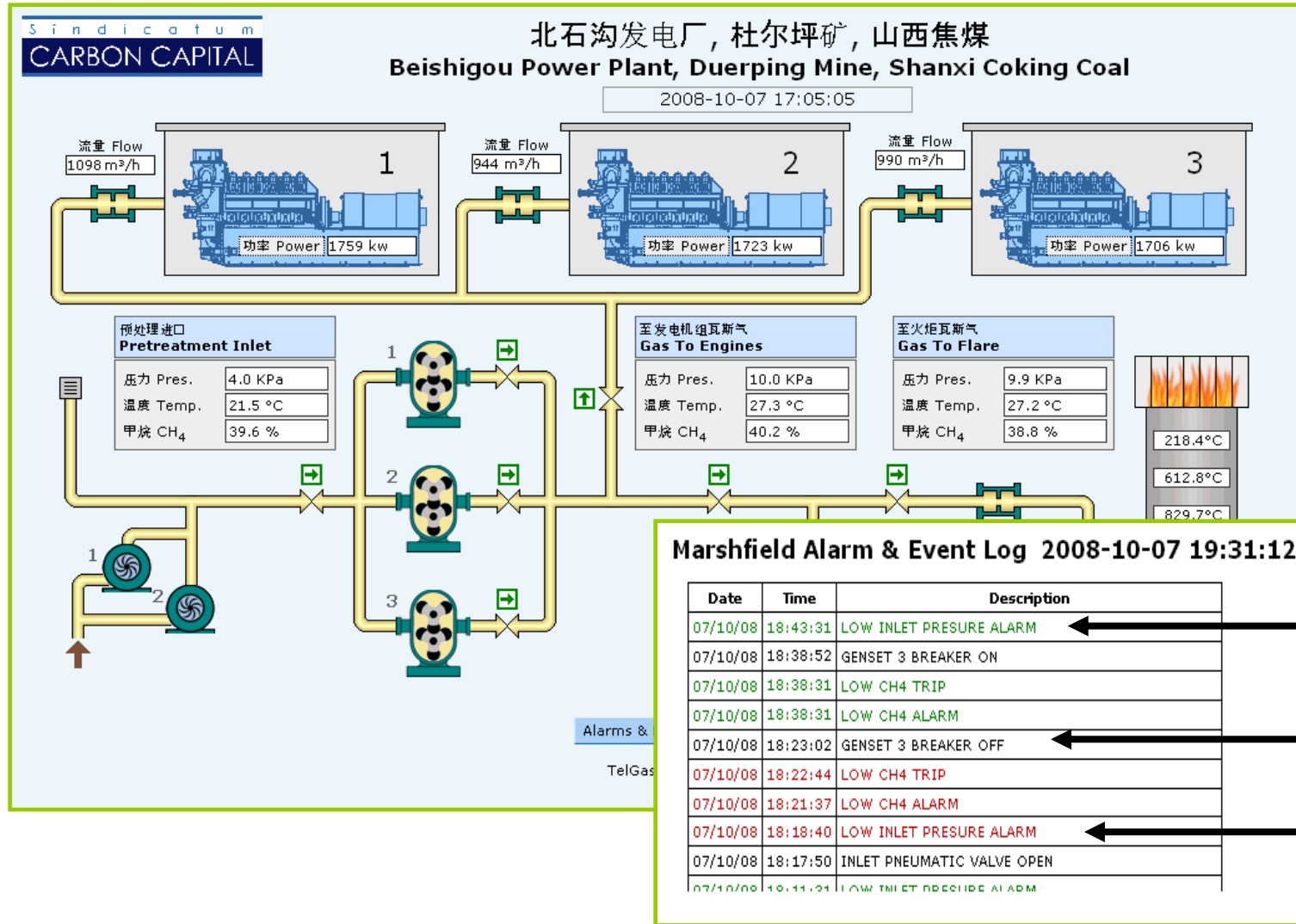

Alarm Off

Event Notification

Alarm On

## CDM monitoring

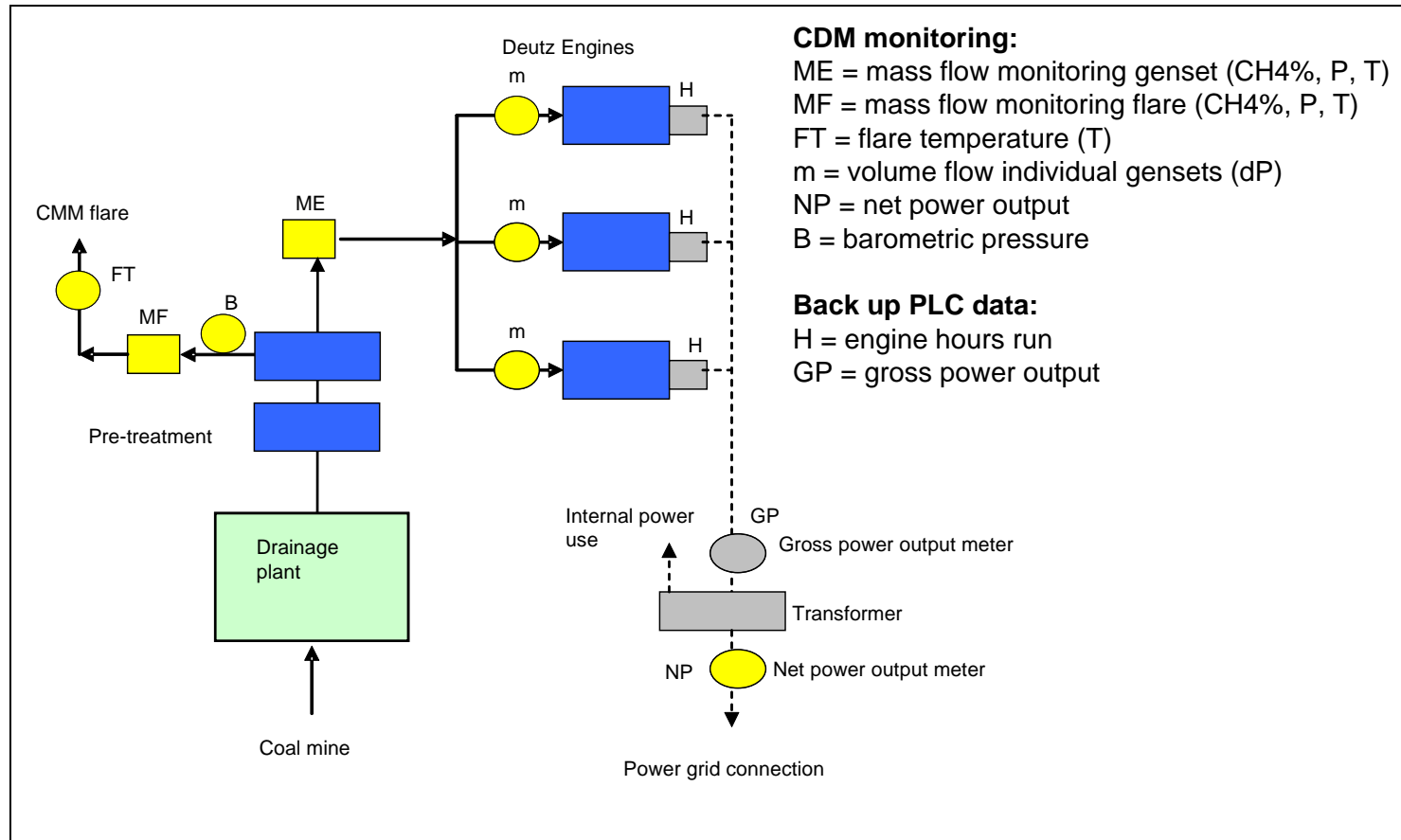

## CDM data collection and processing

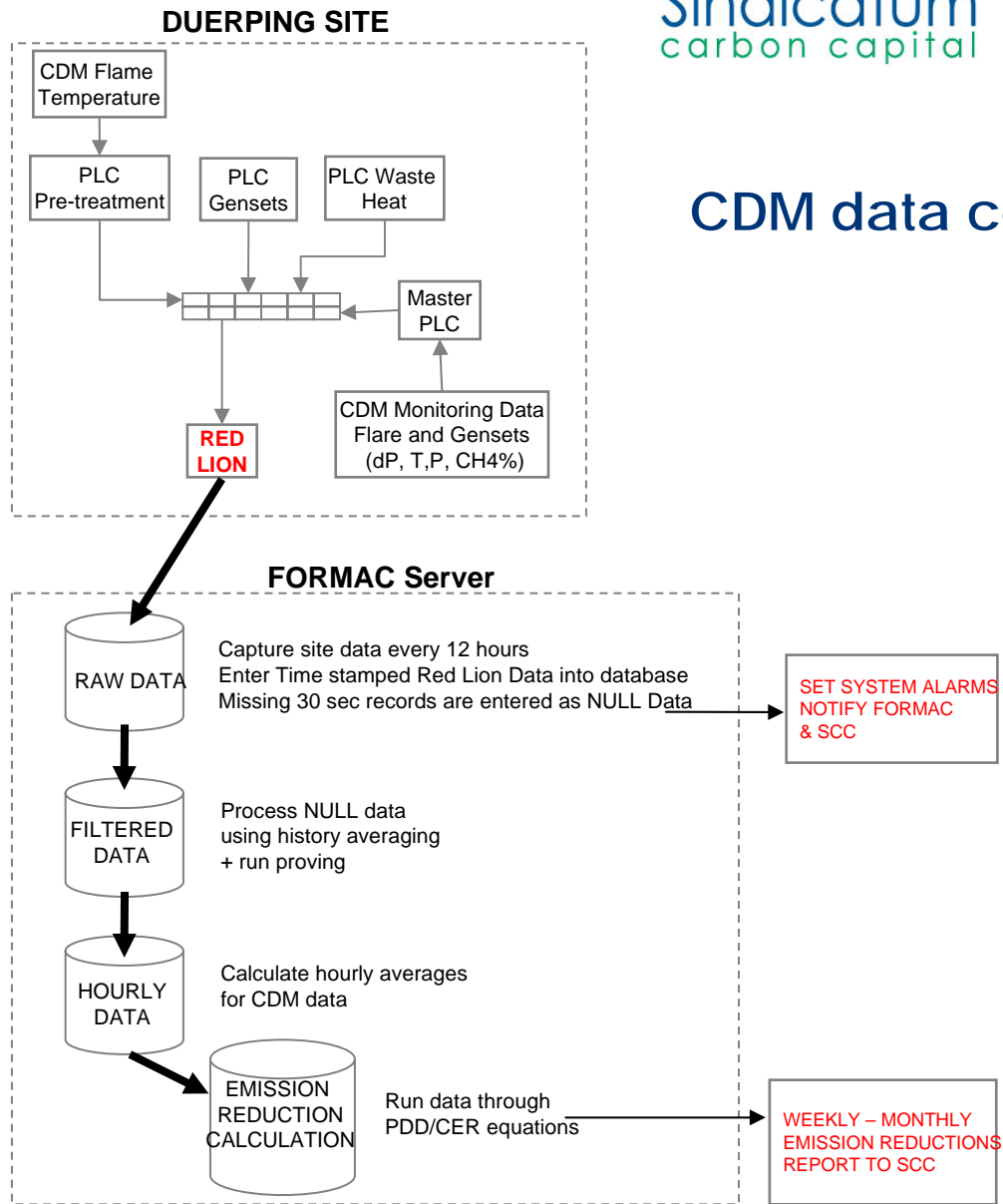

## Technical lessons from the Duerping project

### Gas drainage in the mine

- Standard Chinese flow measurement devices reduce drained gas flows significantly
- Mine gas flow data are not generally corrected to standard conditions
- Mine drained gas concentration measurements are unreliable
- Methane purity can be raised to >30% and there is a direct safety benefit

### Utilisation project design

- Contractor should be responsible for integration of all plant construction and implementation on the power generation site – but limited capability and resource
- More robust water treatment on gas supply from the methane extraction plant
- Gas flow to flares should not be limited by engine gas pre-treatment unit capacity
- More advanced control system integration needed

### CDM monitoring

- Guard gas detectors from water ingress
- Extreme weather protection
- Formal calibration procedures and training
- CER delivery requires dedicated team

**Capacity building is needed locally to facilitate design, manufacturing and installation to achieve the specified equipment performance and by the mines to improve gas management**

# Thank You

**Clark Talkington**

SVP, Coal Solutions Group

SCC Americas LLC

8300 Greensboro Dr, Su 800

McLean, VA 22102

(Tel) +1 703 918 4933

(Mob) +1 703 966 9755

[clark.talkington@sccamericas.com](mailto:clark.talkington@sccamericas.com)

**Dr. David Creedy**

EVP, Coal Mine Methane & Director

Global CMM

Sindicatum Carbon Capital

Floor 26, Oriental Kenzo Building No.

48 Dongzhimenwai St, Dongcheng

District

Beijing 100027

China

Tel: +86 (0)10 5807 2588

Mob +86 139 1015 5524

[david.creedy@carbon-capital.com](mailto:david.creedy@carbon-capital.com)