

## IGPG – Car Wash Round Robin Test Procedure

---

### 1. Scope

The intension of this round robin test is to investigate whether the car wash test described in ISO 20566 and used to validate the abrasion performance of exterior car body parts is suitable as approval test for safety glazing parts.

Therefore different glazing materials will be tested by different test laboratories using the so-called Amtec-Kistler laboratory car wash equipment and following the test procedure described in this document. The haze value increase due to abrasion will be measured as described in ECE R43 for every sample and the results for all samples will be compared and analyzed.

### 2. Apparatus

The so-called Amtec-Kistler laboratory car wash apparatus from Amtec-Kistler GmbH (see annex 1 of this document) in Germany is used or equivalent equipment fulfilling the technical descriptions in ISO 20566.

Use the following equipment of the Amtec-Kistler apparatus:

- a test panel holder with sloped edges (instead of rounded edges used in former version) in order to avoid faster wear out of the brushes
- brush type: polyethylene with a x-shaped, spliced profile

and the following settings by adjusting the variable parameter at the Amtec-Kistler apparatus:

- feed speed of the test panel holder:  $(5 \pm 0,2)$  m/min
- penetration depth of the brush: 100 mm
- speed of the brush rotation:  $(127 \pm 5)$  min<sup>-1</sup>, the rotating direction is opposite to the direction of travel of the test panel holder
- water flow rate  $(2,2 \pm 0,1)$  l/min at  $(300 \pm 50)$  kPa

### 3. Consumable Material

#### 3.1 Polyethylene based Washing Brush

The polyethylene based washing brush is also available from Amtec-Kistler GmbH in Germany or from the supplier mtv messtechnik oHG in Germany.

The state of the brushes should be controlled regularly since they are subject to constant change during use, i.e. test results will not, over time, remain constant. The scratching effect becomes more pronounced after long periods of use.

The minimum requirement in controlling the brush is to monitor the total amount of operating hours in use for the brush and an automatic replacement of the brush as soon as 30 operating hours are reached (30h equates around 300 test runs since one test takes around 6min). The amount of operating hours should be reported with the haze increase result of the sample.

#### 3.2 Washing suspension

The washing suspension which is sprayed via the nozzles of the apparatus onto sample and brush is prepared by using

- micronized silica powder Sikron SH200 from Quarzwerke GmbH in Germany (available in low quantities from Amtec-Kistler GmbH or mtv Messtechnik oHG) (product data sheet available in the internet (main characteristics: average grain size  $d_{50\%}$  24  $\mu$ m; upper grain size  $d_{95\%}$  45  $\mu$ m; spec. surface (DIN ISO 9277) BET 0,5 m<sup>2</sup>/g; chemical analysis ca. 99 wt-% SiO<sub>2</sub>)
- normal tap water at room temperature

and as follows.

## IGPG – Car Wash Round Robin Test Procedure

---

1,5 g of the silica powder per liter of tap water is mixed by stirring vigorously in the corresponding container of the apparatus.

The suspension shall be stirred continuously during the test procedure in such a way that the silica powder does not settle on the bottom of the container as this would result in variations in the concentration.

### 4. Test samples

3 different types of samples each type consisting of 3 identical samples are to be tested by every participating test laboratory. The 3 different types of transparent samples are:

- glass samples
- coated PMMA samples and
- coated PC samples

The size of the samples is 50mm x 100mm.

Prior to testing the samples should be conditioned for at least 24h at an ambient temperature ( $23^{\circ}\text{C} \pm 2^{\circ}\text{C}$ ) and an ambient relative humidity ( $50\% \pm 5\%$ ).

### 5. Procedure

#### 5.1 Prearrangements

The abrasion test shall be carried out at room temperature.

Check the state of the polyethylene brushes as described in 3.1 and replace them if they have reached 30 operating hours in total.

Do the instrument calibration as described in ISO 20566 Annex A. Furthermore perform a trial run without a test panel, carrying out 10 washing operations (10 double passes), to distribute the suspension evenly in the apparatus.

Determine the initial haze of the sample as described in ECE R43 (see Annex 2 of this document). An appropriate instrument for that haze measurement is for example a BYK-Gardener Haze-Gard plus.

#### 5.2 Test

Affix the 50 mm x 100 mm samples with the outside surface face up onto a supporting plate by using a double-faced adhesive tape (two 10mm x 10mm adhesive strips each positioned on one short sides of the sample should be enough). Position the supporting plate with the samples on top on the test jig as illustrated in the following picture.

IGPG – Car Wash Round Robin Test Procedure

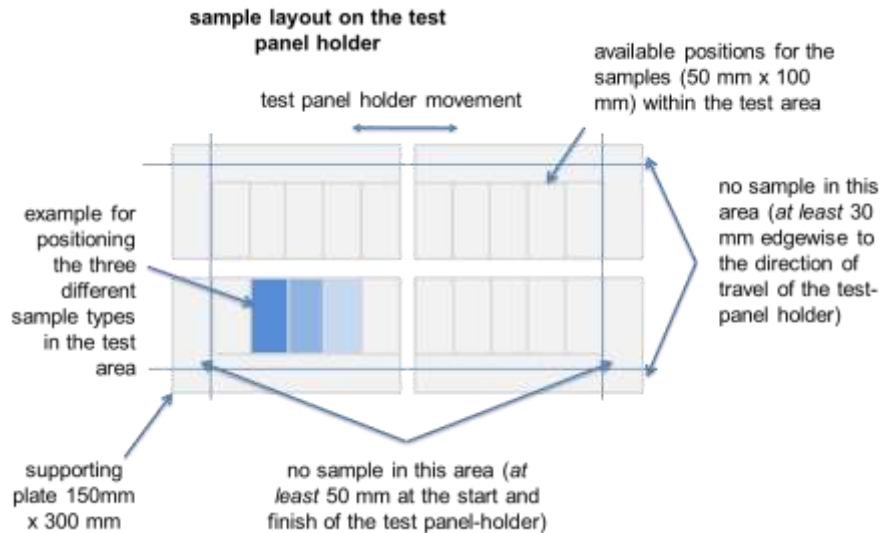

This assures that the test samples are located in the optimal testing area of the test apparatus. The area of at least 50 mm at the start and finish of the test-panel holder and of at least 30 mm edgewise to the direction of travel of the test-panel holder may not be evaluated.

The three different sample types can be tested in one test run, but the identical samples of each type should be tested in different test runs in order to gain results coming from repeated testing.

Carry out 10 washing operations (10 double passes) using the to-and-fro pattern of movement.

Rinse the washed test samples after removing the adhesive tape with cold water, and then clean it with a suitable solvent, e.g. Isopropyl alcohol (IPA), using soft, non-scratching paper tissues and wiping in the direction of the scratches. Finally, leave for 30 min to dry off. This process is designed to remove all residues of silica powder, and any fibers from the brush. In case of any inhomogeneous surface appearance of the sample repeat this cleaning process to ensure complete removal of any residue.

Special care has to be taken in case of single layer coated samples like the PMMA samples in order to not scratch the unprotected / uncoated backside of the sample during this cleaning process by either handling the samples only at the edges or covering the backside with a masking film.

Determine after drying the final haze of the test samples as described ECE R43 (see Annex 2 of this document). An appropriate instruments for that haze measurement is for example a BYK-Gardener Haze-Gard plus. Only make measurements in homogeneous areas.

## 6. Expression of Results

Subtract the average initial haze from the average total light scattered, the difference representing the light scatter resulting from washing the test specimen. Report this difference for 10 washing operations (10 double strokes) for the outside surface of the test samples.

## 7. Report

The report shall contain at least the following information:

- any deviation from the above described equipment, procedure, etc.
- initial, final and delta haze values for each tested individual sample
- the operation hours of the brush when the test was started

IGPG – Car Wash Round Robin Test Procedure

Annex 1

Car wash lab equipment



Manufacturer	Amtec Kistler GmbH; 86931 Prittriching / Germany	
Dimensions (l x w x h)	2 560 mm x 880 mm x 1870 mm	
Brush	diameter	1000 mm
	width	400 mm
	rotation speed	127 min <sup>-1</sup>
	brush rotation	rotates in the opposite direction relative to the direction of travel of the test panel holder
	material	polyethylene
	bristle profile	x-shaped, spliced
	bristle thickness	0,8 mm
	bristle length	440 mm visible
	penetration depth	100 mm
Spray nozzle	number	2 (spray alternatively and against the direction of travel of the test panel holder)
	material	stainless steel
	spread of jet	65°
	water flow rate	(2.2 ± 0.1) l/min @ (300 ± 50) kPa
Test panel holder	feed speed	(5 ± 0.2) m/min
	testing area	300 mm x 300 mm (twice)
	pattern of movement	if the brush is rotating clockwise, the right nozzle is spraying and the test panel holder travels from the left side to the right side (and vice versa)

IGPG – Car Wash Round Robin Test Procedure

---

## Annex 2

Haze measurement according to ECE R43

*Light source* consisting of an incandescent lamp with its filament contained within a parallelepiped measuring 1.5 mm x 1.5 mm x 3 mm. The voltage at the lamp filament shall be such that the color temperature is  $2856 \pm 50$  K. This voltage shall be stabilized within  $\pm 1/1000$ . The instrument used to check the voltage shall be of appropriate accuracy.

*Optical system* consisting of a lens with a focal length  $f$  of at least 500 mm and corrected for chromatic aberrations. The full aperture of the lens shall not exceed  $f/20$ . The distance between the lens and the light source shall be adjusted in order to obtain a light beam which is substantially parallel. A diaphragm shall be inserted to limit the diameter of the light beam to  $7 \pm 1$  mm. This diaphragm shall be situated at a distance of  $100 \pm 50$  mm from the lens on the side remote from the light source.

*Equipment for measuring scattered light* (see following figure), consisting of a photoelectric cell with an integrating sphere 200 to 250 mm in diameter. The sphere shall be equipped with entrance and exit ports for the light. The entrance port shall be circular and have a diameter at least twice that of the light beam. The exit port of the sphere shall be provided with either a light trap or a reflectance standard, according to the procedure described in the paragraph below. The light trap shall absorb all the light when no test piece is inserted in the light beam. The axis of the light beam shall pass through the center of the entrance and exit ports. The diameter  $b$  of the light-exit port shall be equal to  $2a \tan 4^\circ$ , where  $a$  is the diameter of the sphere. The photoelectric cell shall be mounted in such a way that it cannot be reached by light coming directly from the entrance port or from the reflectance standard. The surfaces of the interior of the integrating sphere and the reflectance standard shall be of substantially equal reflectance and shall be matt and non-selective. The output of the photoelectric cell shall be linear within  $\pm 2$  per cent over the range of luminous intensities used. The design of the instrument shall be such that there is no galvanometer deflection when the sphere is dark.

The whole apparatus shall be checked at regular intervals by means of calibration standards of defined haze. If haze measurements are made using equipment or methods differing from those defined above, the results shall be corrected, if necessary, to bring them into agreement with those obtained by the apparatus described above.

IGPG – Car Wash Round Robin Test Procedure

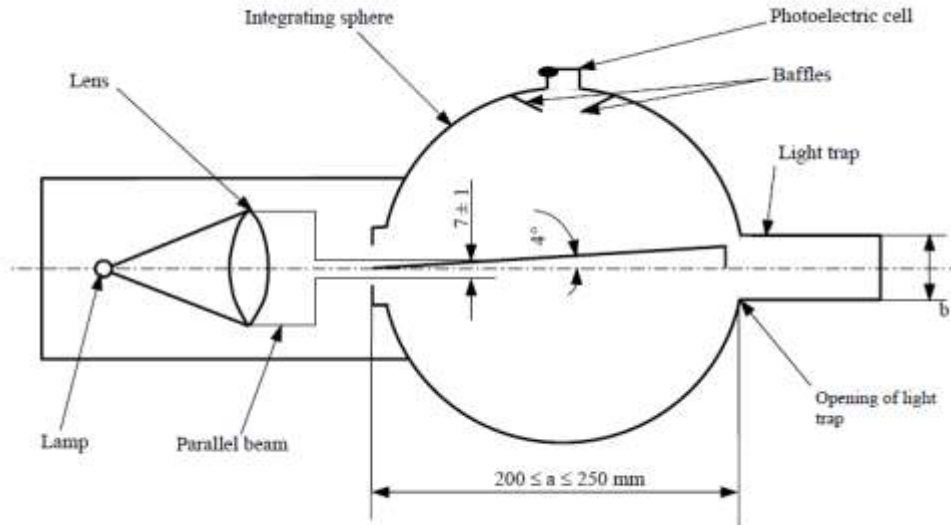

For the *measurement* place the test piece against the entrance port of the integrating sphere. The angle between the normal (perpendicular) to the surface of the test piece and the axis of the light beam shall not exceed 8°.

Take four readings as indicated in the following table:

Reading	With test piece	With light-trap	With reflectance standard	Quantity represented
T <sub>1</sub>	No	No	Yes	Incident light
T <sub>2</sub>	Yes	No	Yes	Total light transmitted by test-piece
T <sub>3</sub>	No	Yes	No	Light scattered by instrument
T <sub>4</sub>	Yes	Yes	No	Light scattered by instrument and test piece

Repeat readings for T<sub>1</sub>, T<sub>2</sub>, T<sub>3</sub>, and T<sub>4</sub> with other specified positions of the test piece to determine uniformity.

Calculate the total transmittance T<sub>t</sub>

$$T_t = \frac{T_2}{T_1}$$

Calculate the diffuse transmittance T<sub>d</sub> as follows:

$$T_d = \frac{T_4 - T_3(T_2/T_1)}{T_1 - T_3}$$

IGPG – Car Wash Round Robin Test Procedure

---

Calculate the percentage haze, or light, or both, scattered, as follows:

$$\frac{T_d}{T_t} \times 100$$

Determine the initial (final) haze of the test piece at a minimum of four points in the unabraded (abraded) area in accordance with the formula above. Average the results for each test piece.