

**Economic and Social Council**

Distr.: General  
31 January 2011

Original: English  
English and French only

---

**Economic Commission for Europe****Inland Transport Committee****World Forum for Harmonization of Vehicle Regulations****Working Party on General Safety Provisions****100<sup>th</sup> session**

Geneva, 11–15 April 2011

Item 12 of the provisional agenda

**Regulation No. 125 (Forward field of vision of drivers)****Proposal for amendments to Regulation No. 125 (Forward field of vision of drivers)****Submitted by the expert from Japan \***

The text reproduced below was prepared by the expert from Japan. It is based on ECE/TRANS/WP.29/GRSG/2010/4 and informal documents GRSG-99-09-Rev.1 and GRSG-99-27 distributed at the ninety-ninth session of the Working Party on General Safety Provisions (GRSG). The modifications to the current text of the Regulation are marked in bold for new or strikethrough for deleted characters.

---

\*In accordance with the programme of work of the Inland Transport Committee for 2010–2014 (ECE/TRANS/208, para. 106 and ECE/TRANS/2010/8, programme activity 02.4), the World Forum will develop, harmonize and update Regulations in order to enhance the performance of vehicles. The present document is submitted in conformity with that mandate.

## I. Proposal

Paragraph 2.16., amend to read:

"2.16. "A pillar" means ~~any~~ **the foremost and outermost** roof support forward of the vertical transverse plane located 68 mm in front of the V points and includes non-transparent items such as windscreen mouldings and door frames, attached or contiguous to such a support."

Insert new paragraph 5.1.4 (including new figure 1), to read:

"5.1.4. A 1.2 m-tall cylindrical object with a diameter of 0.3 m that is situated inside the space bounded by a vertical plane located 2.0 m in front of the vehicle, a vertical plane located 2.3 m in front of the vehicle, a vertical plane located 0.4 m from the driver's side of the vehicle, and a vertical plane located 0.6 m from the opposite side of the vehicle shall be at least partially visible when viewed directly from V2 (see figure 1), regardless of where the object is within that space, unless it is invisible due to a blind spot(s) created by the A pillars, windscreen wipers, or steering wheel.

Figure 1

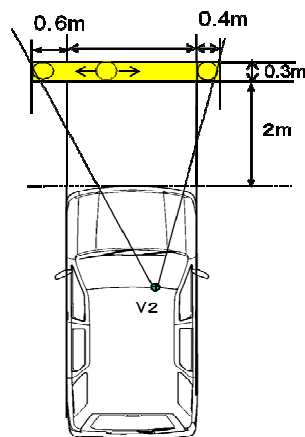

## II. Justification

### Paragraph 2.16.:

1. Some vehicles look as if they had two A-pillars in each side. In this case, the number of A pillar seems to be in conflict with paragraph 5.1.2.2. Therefore, the definition of "A pillar" is clarified by aligning it with Regulation No. 29.

### Paragraph 5.1.4.:

2. This proposal is a modified version of ECE/TRANS/WP.29/GRSG/2010/4, which was submitted for the purpose of preventing road accidents due to the inability of drivers of

vehicles with an extremely high eye point to view small vehicles (e.g., motorcycles) in front.

3. ECE/TRANS/WP.29/GRSG/2010/4 proposed to add a new provision to paragraph 5.1.3. However, its relation to the area S of paragraph 5.1.3.1., proposed in ECE/TRANS/WP.29/GRSG/2009/20, was unclear. In order to clarify that relation, this proposal proposes to delete the language that had been added to paragraph 5.1.3. and to insert a new paragraph 5.1.4., thereby making it clear that the new provision is independent from the provision on the area S in paragraph 5.1.3.1.

4. The drivers of vehicles with an eye point of regular height, that satisfy paragraph 5.1.3., are able to view small vehicles in front. But with vehicles with an extremely high eye point, it can be difficult for their drivers to view some small vehicles even when paragraph 5.1.3. is met. New paragraph 5.1.4. can prevent this problem.

5. The wording "there should be no obstruction" was proposed in ECE/TRANS/WP.29/GRSG/2010/4. But the original objective of the proposal is to make it possible for drivers to view objects on the road (e.g., motorcycles) with a size equal to or more than the specified size. To be in line with that objective, this proposal changes the wording to "a 1.2 m-tall cylindrical object with a diameter of 0.3 m ... shall be at least partially visible".

---