

INTA	29 th GRSP	May 2001
	REGULATION ECE R14	

Informal document N: 16
29th GRSP, May 2001.

**PROPOSAL FOR A CORRIGENDUM TO
DRAFT SUPPLEMENT N.2 TO THE REGULATION ECE R14.05.**

1. PROPOSAL:

Paragraph 5.4.2.5: to be amended as follow.

- "... not less than 350 mm. For rear central seating positions of M1 or N1 vehicles, that distance may be not less than 240mm in case of bench seats, or individual seats provided that they may nor be interchanged with any seat located in an outboard position. The median longitudinal...." (see annexed drawing)
- Footnote: To be deleted.

2. JUSTIFICATION:

The proposed by GRSP reduction for the minimum distance between rear central seat effective anchorages was amended by WP29. It was specified in a footnote that the reduction should be only applicable for bench seats, not for individual seats.

This restriction try to avoid that an individual seat fitted with the reduced distance, could be interchanged with an other individual seat located outboard. (In many monospace type vehicles, rear seats are individual seats, and may easily be interchanged)

We believe that the proposed corrigendum is able to permit a design freedom, keeping the restriction wished by WP29.

• (effective anchorages)

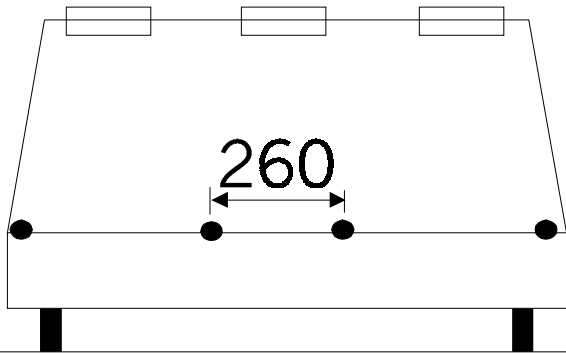

DRAWING 1

vehicle OK

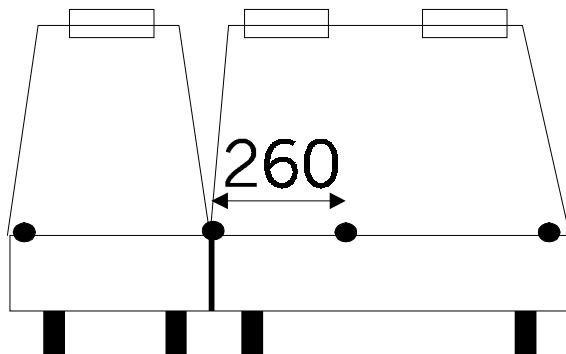

DRAWING 2

vehicle OK

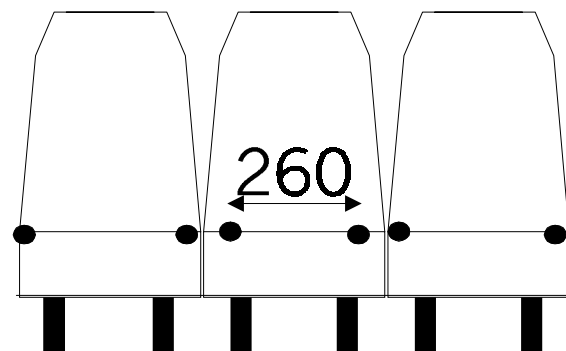

DRAWING 3

vehicle NOT OK
central seat
MAY BE
interchanged with
outboard seats

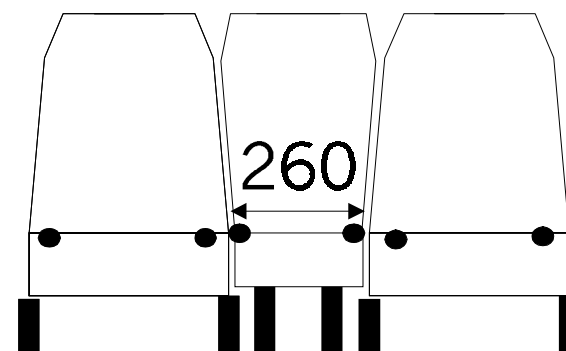

DRAWING 4

vehicle OK
central seat
MAY NOT be
interchanged with
outboard seats