

Distr.
GENERAL

TRANS/WP.29/GRSG/2000/19
3 August 2000

ENGLISH
Original: FRENCH

ECONOMIC COMMISSION FOR EUROPE

INLAND TRANSPORT COMMITTEE

World Forum for Harmonization of Vehicle Regulations (WP.29)

Working Party on General Safety Provisions (GRSG)
(Seventy-ninth session, 16-20 October 2000,
agenda item 11.6)

**NEW DRAFT REGULATION
UNIFORM TECHNICAL PROVISIONS CONCERNING
THE FORWARD FIELD OF VISION OF DRIVERS**

Transmitted by the expert from Belgium

Note: The text reproduced below was prepared by the expert from Belgium. Its purpose is to introduce harmonized requirements concerning the driver's forward field of vision. It supplements the provisions concerning safety glazing. The document reflects the opinion of the ad hoc working group on safety glazing and glazing material following its meeting in Brussels in January 2000.

Note: This document is distributed to the Experts on General Safety Provisions only.

Regulation No. xxxUniform technical provisions concerning the field of vision of drivers of motor vehicles

CONTENTS

	<u>Page</u>
1. SCOPE	4
2. DEFINITIONS	4
3. APPLICATION FOR APPROVAL	6
4. APPROVAL	6
5. SPECIFICATIONS	8
6. TEST PROCEDURE	10
7. MODIFICATION OF VEHICLE TYPE AND EXTENSION OF APPROVAL	10
8. CONFORMITY OF PRODUCTION	11
9. PENALTIES FOR NON-CONFORMITY OF PRODUCTION	11
10. PRODUCTION DEFINITELY DISCONTINUED	11
11. NAMES AND ADDRESSES OF THE TECHNICAL SERVICES RESPONSIBLE FOR CONDUCTING APPROVAL TESTS AND OF ADMINISTRATIVE DEPARTMENTS	12
 ANNEXES	
<u>Annex 1</u> Model communication sheet concerning the granting, extension, refusal or withdrawal of approval or production definitely discontinued of a type of vehicle pursuant to Regulation No. XX	13
<u>Annex 2</u> Arrangements of approval marks	15

CONTENTS (continued)

	<u>Page</u>
<u>Annex 3</u> Procedure to determine the H point and the actual seat-back angle and to ascertain the relative positions of the R and H points and the relation between the design seat-back angle and the actual seat-back angle	16
<u>Annex 4</u> Method to determine the dimensional relationships between the vehicle's primary reference marks and the three-dimensional reference system	26
<u>Annex 5</u> Geometrical relationships between the positions of the V, P, E points and the R point	31

1. SCOPE

This Regulation applies to the 180° forward field of vision of drivers of category M vehicles.¹ Its purpose is to ensure an adequate field of vision in all circumstances [when the windscreen and other glazed surfaces are dry and clean]. These requirements apply to vehicles with left-wheel drive. In the case of right-wheel drive vehicles, they shall apply mutatis mutandis by inverting the criteria in question.

2. DEFINITIONS

For the purposes of this Regulation:

- 2.1 “Approval of a vehicle type” means the full procedure whereby a Contracting Party to the Agreement certifies that a vehicle type meets the technical requirements of this Regulation;
- 2.2 “Vehicle type” means (as regards the driver’s forward field of vision) a group of vehicles which do not differ essentially in respect of the following features:
- 2.2.1 the name and corporate name of the constructor;
- 2.2.2 the internal and external fittings which may, within the area defined as the forward field of vision, affect the driver’s visibility;
- 2.2.3 the shape and dimensions of the windscreen;²
- 2.2.4 the position of the windscreen, and in particular its angle and its position in relation to the driver’s R point.
- 2.2.5 “Mass of the vehicle in running order” means the mass of the vehicle and its body with cooling fluid, lubricants, fuel, 100% of other liquids, tools, spare wheel and driver.³
- 2.4 “Three-dimensional reference system” means a reference system which consists of a vertical longitudinal plane X-Z, a horizontal plane X-Y and a vertical

¹ As defined in the Consolidated Resolution on the Construction of Vehicles (R.E.3) (document TRANS/WP.29/78/Rev.1/Amend.2).

² The thickness of the windscreen is not a criterion within the meaning of 2.2.3.

³ The mass of the driver is evaluated at 75 kilograms (distributed as follows: 68 kilograms for the mass of the occupant and 7 kg for the mass of luggage, in accordance with ISO Standard 2416-1992. The tank contains 90% and the other liquid-containing appliances (other than those intended for waste water) 100% of the capacity declared by the manufacturer.

transverse plane Y-Z (see Annex 4, Appendix 1, figure 3), used to determine the relative distances between the position of design points on plans and their actual position on the vehicle;

- 2.4.1 Vehicles fitted with suspension enabling their ground clearance to be adjusted shall be tested under the normal conditions of use specified by the vehicle manufacturer.
- 2.5 “Primary reference marks” means holes, surfaces, marks and identification signs on the vehicle body. The type of reference mark used and the position of each mark (relative to the X, Y and Z coordinates of the three-dimensional reference system) and their distance in relation to a design ground plane shall be specified by the vehicle manufacturer. These marks may be the control points used for body-assembly purposes.
- 2.6 “Seat-back angle” means the angle defined in Annex 3, paragraph 2.5.
- 2.7 “Actual seat-back angle” means the angle defined in Annex 3, paragraph 2.6.
- 2.8 “Design seat-back angle” means the angle defined in Annex 3, paragraph 2.7.
- 2.9 “R point” (seating reference point) means the point defined in Annex 3, paragraph 2.4.
- 2.10 “H point” (reference point of the 3 DH machine) means the point defined in Annex 3, paragraph 2.3.
- 2.11 “Horizontal seat-adjustment range” means the range of normal driving positions designated by the vehicle manufacturer for the adjustment of the driver’s seat in the direction of the X axis of the three-dimensional reference system.
- 2.12 “Extended seat-adjustment range” means the range designated by the vehicle manufacturer for the adjustment of the seat in the direction of the X axis of the three-dimensional reference system beyond the range of normal driving positions specified in paragraph 2.11 [and used for converting seats into beds or facilitating entry to the vehicle].
- 2.13 “V points” means points whose position in the passenger compartment is determined by vertical longitudinal planes passing through the centres of the [outermost] design seating positions on the front seat and in relation to the R point and the design angle of the seat-back, used to verify compliance with requirements concerning the driver’s forward field of vision.
- 2.14 “Windscreen datum points ‘Pri’” means points situated at the intersection with the windscreen of lines radiating forward from the V points to the outer surface of the windscreen.

- 2.15 “Transparent area” means that area of a vehicle windscreen or other glazed surface whose light transmittance factor measured at right angles to the surface is not less than 70%.
- 2.16 “P points” means the points about which the driver’s head rotates when he views objects on a horizontal plane at eye level.
- 2.17 “E points” means points representing the centres of the driver’s eyes and used to assess the extent to which A pillars obscure the field of vision.
- 2.18 “A pillars” means any roof support forward of the vertical transverse plane located 68 m in front of the V points and includes non-transparent items such as windscreen mouldings and door frames, attached or contiguous to such a support.

3. APPLICATION FOR APPROVAL

- 3.1 The application for approval of a vehicle type with regard to the driver’s field of vision shall be submitted by the vehicle manufacturer or his duly accredited representative.
- 3.2 It shall be accompanied by the documents mentioned below in triplicate and include the following particulars:
- 3.2.1 a detailed description of the vehicle type with regard to the criteria referred to in paragraph 2.2 above, together with dimensional drawings and either a photograph or an exploded view of the passenger compartment. The numbers and/or symbols identifying the vehicle type shall be specified;
- 3.2.2 particulars of the primary reference marks in sufficient detail to enable them to be readily identified and their position ascertained with reference to the R point.
- 3.3 A vehicle representative of the vehicle type to be approved shall be submitted to the technical service conducting the approval tests.

4. APPROVAL

- 4.1 If the vehicle type submitted for approval under this Regulation meets the requirements of paragraph 5 below, approval shall be granted.
- 4.2 An approval number shall be assigned to each type approved; its first two digits (00 for the Regulation in its initial form) shall indicate the series of amendments incorporating the most recent technical amendments made to the Regulation at the time of issue of the approval. The same Contracting Party shall not assign the same number to another vehicle type.

- 4.3 Notice of approval or extension of its scope, or of refusal or withdrawal of approval, or of production definitely discontinued shall be communicated to the Contracting Parties to the Agreement applying this Regulation by means of a form conforming to the model in Annex 1 and photographs and/or plans supplied by the applicant being in a format not exceeding A4 (210 x 287 mm), or folded to that format, and on an appropriate scale.
- 4.4 There shall be affixed, conspicuously and in a readily accessible place specified on the approval form, to every vehicle conforming to a vehicle type approved under this Regulation, an approval mark conforming to the model described in Annex 2, consisting of:
- 4.4.1 a circle surrounding the letter "E" followed by the distinguishing number of the country which has granted approval;⁴
- 4.4.2 the number of this Regulation, followed by the letter "R", a dash and the approval number to the right of the circle prescribed in paragraph 4.4.1 above.
- 4.5 If the vehicle conforms to a vehicle type approved under one or more other Regulations, annexed to the Agreement, the symbol prescribed in paragraph 4.4.1 need not be repeated; in such a case, the approval numbers and the additional symbols shall be placed in vertical columns to the right of the symbol prescribed in paragraph 4.4.1 above.
- 4.6 The approval mark shall be clearly legible and be indelible.
- [4.7 The approval mark shall be placed close to or on the vehicle data plate.]

⁴ 1 for Germany, 2 for France, 3 for Italy, 4 for the Netherlands, 5 for Sweden, 6 for Belgium, 7 for Hungary, 8 for the Czech Republic, 9 for Spain, 10 for Yugoslavia, 11 for the United Kingdom, 12 for Austria, 13 for Luxembourg, 14 for Switzerland, 15 (vacant), 16 for Norway, 17 for Finland, 18 for Denmark, 19 for Romania, 20 for Poland, 21 for Portugal, 22 for the Russian Federation, 23 for Greece, 24 for Ireland, 25 for Croatia, 26 for Slovenia, 27 for Slovakia, 28 for Belarus, 29 for Estonia, 30 (vacant), 31 for Bosnia and Herzegovina, 32 for Latvia, 33 (vacant), 34 for Bulgaria, 35 and 36 (vacant), 37 for Turkey, 38 and 39 (vacant), 40 for the former Yugoslav Republic of Macedonia, 41 (vacant), 42 for the European Community (approvals are granted by the member States which use their own EEC approval marks), 43 for Japan, 44 (vacant), 45 for Australia and 46 for Ukraine. Subsequent numbers shall be assigned to other countries in the chronological order in which they ratify the Agreement Concerning the Adoption of Uniform Technical Prescriptions for Wheeled Vehicles, Equipment and Parts which can be fitted and/or be used on Wheeled Vehicles and the Conditions for Reciprocal Recognition of Approvals Granted on the Basis of these Prescriptions, or in which they accede to that Agreement, and the numbers thus assigned shall be communicated by the Secretary-General of the United Nations to the Contracting Parties to the Agreement.

5. SPECIFICATIONS

5.1 Driver's field of vision.

5.1.1. The transparent area of the windscreen must include at least the windscreen datum points (see Annex 5, Appendix 1, figure 6):

5.1.1.1 a horizontal datum point "Pr1" forward of V_1 and 17° to the left;

5.1.1.2 a vertical datum point "Pr2" forward of V_1 and 7° above the horizontal;

5.1.1.3 a vertical datum point "Pr3" forward of V_2 and 5° below the horizontal;

5.1.1.4 to verify visibility on the opposite half of the windscreen, three other datum points "Pr'i" are taken, symmetrical with the points defined in paragraphs 5.1.1.1 to 5.1.1.3 in relation to the median longitudinal plane of the vehicle.

5.1.2 The angle of obstruction of the A pillars, as defined in paragraph 5.1.2.1, shall not exceed 6° (see Annex 5, Appendix 3, figure 9).

The angle of obstruction of the A pillar on the passenger side, as defined in paragraph 5.1.2.1.1, need not be determined if the two pillars are located symmetrically in relation to the median longitudinal vertical plane of the vehicle.

5.1.2.1 The angle of obstruction of each A pillar shall be measured by superimposing in a plane the following two horizontal sections:

- Section 1: Starting from the Pm point situated at the location defined in paragraph 5.3.1.1, draw a plane forming an angle of 2° upwards in relation to the horizontal plane passing forward through Pm. Determine the horizontal section of the A pillar starting from the foremost point of the intersection of the A pillar and the inclined plane (see Annex 5, Appendix 3, figure 8).
- Section 2: Repeat the same procedure, taking a plane declining at an angle of 5° downwards in relation to the horizontal plane passing forward through Pm (see Annex 5, Appendix 3, figure 8).

5.1.2.1.1 The angle of obstruction of the A pillar on the driver's side is the angle formed on the plane view by a parallel, starting from E_2 , to the tangent joining E_1 to the outer edge of section S_2 and the tangent joining E_2 to the inner edge of section S_1 (see Annex 5, Appendix 3, figure 9).

- 5.1.2.1.2 The angle of obstruction of the A pillar on the passenger side is the angle formed on the plane view by the tangent joining E_3 to the inner edge of section S_1 and the tangent joining E_4 to the outer edge of section S_2 (see Annex 5, Appendix 3, figure 9).
- 5.1.3 There should be no obstruction in the driver's 180° forward direct field of vision below a horizontal plane passing through V_1 , and above three planes through V_2 , one being perpendicular to the plane X-Z and declining forward 4° below the horizontal, and the other two being perpendicular to the plane Y-Z and declining 4° below the horizontal (see Annex 5, Appendix 2, figure 7).
- 5.1.4 The following are not considered to be obstructions to the field of vision within the meaning of paragraph 5.1.3:
- obstructions created by the A pillars equal to or less than 6°;
 - fixed or movable vent or side window division bars;
 - outside radio aerials;
 - rear-view mirrors;
 - windscreen wipers;
 - embedded or printed “radio aerial” conductors,⁵ the former no wider than 0.5 mm and the latter than 1.0 mm;
 - “defrosting/demisting” conductors located within zone A [normally in “zigzag” or sinusoidal form] having a maximum visible width of 0.030 mm and a maximum density of 8/cm in the case of vertical conductors and 5/cm in the case of horizontal conductors.
- 5.1.5 An obstruction created by the steering-wheel rim and the instrument panel inside the steering wheel will be tolerated if a plane through V_2 , perpendicular to the plane X-Z and tangential to the highest part of the steering-wheel rim, is declined at least 1° below the horizontal.

⁵ These “radio aerial” conductors shall not cross zone A, as defined in Annex 18, paragraph 2.2 of Regulation No. 43 concerning the approval of safety glazing and glazing material. However, three “radio aerial” conductors may cross zone A if their width does not exceed 0.5 mm.

6. TEST PROCEDURE

6.1 Driver's field of vision.

6.1.1 The dimensional relationships between the vehicle's primary reference marks and the three-dimensional reference system shall be determined by the procedure prescribed in Annex 4.

6.1.2 The position of the points V_1 and V_2 is determined in relation to the R point as indicated by the x, y and z coordinates of the three-dimensional reference system, taken from Annex 5, table I, and, where applicable, corrected according to Annex 5, table IV. The windscreen datum points are determined from the V points once these are correctly located, as indicated in paragraph 5.1.1.

6.1.3 The relative positions of the P and R points and the centre-line of the driver's seating position, expressed in x, y and z coordinates in the three-dimensional reference system, are determined according to Annex 5, tables II and III. The corrections to be made to these coordinates for design seat-back angles other than 25° are shown in Annex 5, table IV.

6.1.4 The angle of obstruction (see paragraph 5.1.2) shall be measured in the inclined planes, as indicated in Annex 5, Appendix 2, figure 7. The relationship between P_1 and P_2 , which are connected to E_1 and E_2 and E_3 and E_4 respectively, is shown in Annex 5, paragraph 5 and illustrated by Annex 5, Appendix 3, figure 9.

6.1.4.1 Straight line E_1 - E_2 shall be set as described in paragraph 5.5.2. The angle of obstruction of the A pillar on the driver's side shall be measured in accordance with paragraph 5.1.2.1.1.

6.1.4.2 Straight line E_3 - E_4 shall be set as described in paragraph 5.5.4. The angle of obstruction of the A pillar on the passenger side shall be measured in accordance with paragraph 5.1.2.1.2.

6.1.5 [The manufacturer may measure the angle of obstruction either on the vehicle or in the drawings. In the event of doubt, the technical services may require the tests be carried out on the vehicle].

7. MODIFICATION OF VEHICLE TYPE AND EXTENSION OF APPROVAL

7.1 Every modification of the vehicle type as defined in paragraph 2.2 below shall be notified to the administrative department which approved the vehicle type. The department may then either:

7.1.1 – consider that the modifications made do not have an adverse effect on the conditions of the granting of the approval and grant an extension of approval;

7.1.2 – consider that the modifications made affect the conditions of the granting of the approval and require further tests or additional checks before granting an extension of approval.

7.3 Confirmation or refusal of approval, specifying the alterations, shall be communicated by the procedure specified in paragraph 4.3 above to the Contracting Parties to the Agreement which apply this Regulation.

7.4 The competent authority shall inform the other Contracting Parties of the extension by means of the communication form which appears in Annex 2 to this Regulation. It shall assign a serial number to each extension, to be known as the extension number.

8. CONFORMITY OF PRODUCTION

8.1 Procedures concerning conformity of production shall conform to the general provisions defined in Appendix 2 to the Agreement and meet the following requirements:

8.2 A vehicle approved pursuant to this Regulation shall be so manufactured as to conform to the type approved by meeting the requirements of paragraph 5 above;

8.3 The competent authority which has granted approval may at any time verify the conformity of control methods applicable to each production unit. The normal frequency of such inspections shall be once every two years.

9. PENALTIES FOR NON-CONFORMITY OF PRODUCTION

9.1 The approval granted in respect of a vehicle type pursuant to this Regulation may be withdrawn if the requirements laid down in paragraph 8 above are not complied with [or if the vehicle or vehicles selected have not passed satisfactorily the inspections referred to in paragraph 8.2 above].

9.2 If a Contracting Party withdraws an approval it had previously granted, it shall forthwith so notify the other Contracting Parties applying this Regulation by sending them a communication form conforming to the model in Annex 1 to this Regulation.

10. PRODUCTION DEFINITELY DISCONTINUED

If the holder of the approval completely ceases to manufacture a type of vehicle approved in accordance with this Regulation, he shall so inform the authority which granted the approval, which in turn shall forthwith inform the other Contracting Parties to the Agreement applying this Regulation by means of a communication form conforming to the model in Annex 1 to this Regulation.

11. NAMES AND ADDRESSES OF THE TECHNICAL SERVICES
RESPONSIBLE FOR CONDUCTING APPROVAL TESTS AND OF
ADMINISTRATIVE DEPARTMENTS

The Contracting Parties to the Agreement applying this Regulation shall communicate to the United Nations Secretariat the names and addresses of the Technical Services responsible for conducting approval tests and of the administrative departments which grant approval and to which forms certifying approval or extension or refusal or withdrawal of approval are to be sent.

Annex 1

(Maximum format: A4 (210 x 297 mm))

COMMUNICATION



Issued by: Name of administration

.....
.....
.....

- Concerning: 2/APPROVAL GRANTED
APPROVAL EXTENDED
APPROVAL REFUSED
APPROVAL WITHDRAWN
PRODUCTION DEFINITELY DISCONTINUED

of a type of vehicle with regard to the driver's forward field of vision pursuant to Regulation No. XX

Approval No.: Extension No.:

1. Trademark:
2. Type and trade name(s):
3. Name and address of manufacturer:
4. If applicable, name and address of manufacturer's representative:
.....
5. Brief description of vehicle:
6. Data to enable the identification of reference point R of the seating position designated for the driver in relation to the primary reference marks:
.....
7. Identification, place and relative positions of the primary reference marks:
.....
8. Date of submission of vehicle for approval:
9. Technical service performing the approval tests:

10. Date of report issued by that service:
11. Number of report issued by that service:
12. Approval with regard to the driver's field of vision is granted/refused 2/:
13. Place:
14. Date:
15. Signature:
16. Annexed to this communication are the following documents, bearing the approval number indicated above:
..... dimensional drawings
..... exploded view or photograph of the passenger compartment
17. Any remarks:

1/ Distinguishing number of the country which has granted/extended/refused/withdrawn an approval (see approval provisions in the Regulation).

2/ Delete what does not apply.

Annex 2

ARRANGEMENTS OF APPROVAL MARKS

(see paragraphs 4.4 to 4.4.2 of this Regulation)

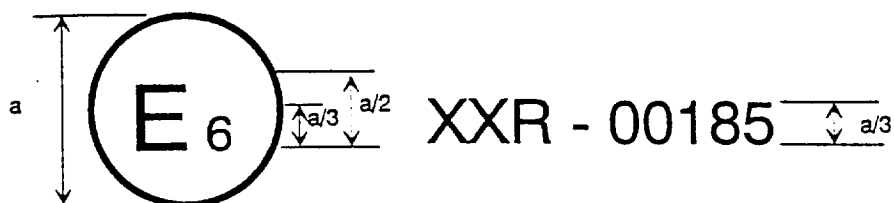

a = 8 mm min

The above approval mark affixed to a vehicle shows that the vehicle type concerned has been approved in Belgium (E6) with regard to the driver's forward field of vision pursuant to Regulation No. xx. The first two digits of the approval number indicate that the approval was granted in accordance with the requirements of Regulation No. xx in its original form.

Annex 3

PROCEDURE FOR DETERMINING THE H POINT AND THE ACTUAL TORSO ANGLE FOR SEATING POSITIONS IN MOTOR VEHICLES

1. PURPOSE

The procedure described in this Annex is used to establish the H point location and the actual torso angle for one or several seating positions in a motor vehicle and to verify the relationship of measured data to design specification given by the vehicle manufacturer.¹

2. DEFINITIONS

For the purposes of this annex.

2.1 “Reference data” means one or several of the following characteristics of a seating position:

2.1.1 the H point and the R point and their relationship;

2.1.2 the actual torso angle and the design torso angle and their relationship.

2.2 “Three-dimensional H-point machine” (3 DH machine) means the device used for the determination of H points and actual torso angles.
This device is described in appendix 1 to this annex.

2.3 “H point” means the pivot centre of the torso and thigh of the 3 DH machine installed in the vehicle seat in accordance with the procedure described in paragraph 4 below. The H point is located in the centre of the centre line of the device which is between the H point sight buttons on either side of the 3 DH machine. The H point corresponds theoretically to the R point (for tolerances, see paragraph 3.2.2 below). Once determined in accordance with the procedure described in paragraph 4, the H point is considered as fixed in relation to the seat-cushion structure and as moving with it when the seat is adjusted.

2.4 “R point” or “seating reference point” means a design point defined by the vehicle manufacturer for each seating position and established with respect to the three-dimensional reference system.

¹ In any seating position other than front seats where the H point cannot be determined using the three-dimensional machine or other procedures, the R point indicated by the vehicle manufacturer may be taken as a reference at the discretion of the competent authority.

- 2.5 “Torso line” means the centre line of the probe of the 3 DH machine with the probe in the fully rearward position.
- 2.6 “Actual torso angle” means the angle measured between a vertical line through the H point and the torso line using the back angle quadrant on the 3 DH machine. The actual torso angle corresponds theoretically to the design torso angle (for tolerances, see paragraph 3.2.2 below).
- 2.7 “Design torso angle” means the angle measured between a vertical line through the R point and the torso line in a position corresponding to the design position of the seat-back specified by the vehicle manufacturer.
- 2.8 “Centre plane of occupant” (CPO) means the median plane of the 3 DH machine positioned in each designated seating position; it is represented by the coordinate of the H point on the Y axis. For individual seats, the centre plane of the seat coincides with the centre plane of the occupant. For other seats, the centre plane of the occupant is specified by the manufacturer.
- 2.9 “Three-dimensional reference system” means a system as described in Annex 4, Appendix 1.
- 2.10 “Fiducial marks” are physical points (holes, surfaces, marks or indentations) on the vehicle body as defined by the manufacturer.
- 2.11 “Vehicle measuring attitude” means the position of the vehicle as defined by the coordinates of fiducial marks in the three-dimensional reference system.

3. REQUIREMENTS

3.1 Data presentation

For each seating position where reference data are required in order to demonstrate compliance with the provisions of this Regulation, all or an appropriate selection of the following data shall be presented in the form indicated in Annex 4, Appendix 2.

- 3.1.1 the coordinates of the R point relative to the three-dimensional reference system;
- 3.1.2 the design torso angle;
- 3.1.3 all indications necessary to adjust the seat (if it is adjustable) to the measuring position set out in paragraph 4.3 below.
- #### 3.2 Relationship between measured data and design specifications

- 3.2.1 The coordinates of the H point and the value of the actual torso angle obtained by the procedure set out in paragraph 4 below shall be compared, respectively, with the coordinates of the R point and the value of the design torso angle indicated by the vehicle manufacturer;
- 3.2.2 The relative positions of the R point and the H point and the relationship between the design torso angle and the actual torso angle shall be considered satisfactory for the seating position in question if the H point, as defined by its coordinates, lies within a square of 50 mm side with horizontal and vertical sides whose diagonals intersect at the R point, and if the actual torso angle is within 5° of the design torso angle;
- 3.2.3 If these conditions are met, the R point and the design torso angle shall be used to demonstrate compliance with the provisions of this Regulation;
- 3.2.4 If the H point or the actual torso angle does not satisfy the requirements of paragraph 3.2.2 above, the H point and the actual torso angle shall be determined twice more (three times in all). If the results of two of these three operations satisfy the requirements, the conditions of paragraph 3.2.3 above shall apply;
- 3.2.5 If the results of at least two of the three operations described in paragraph 3.2.4 above do not satisfy the requirements of paragraph 3.2.2 above, or if the verification cannot take place because the vehicle manufacturer has failed to supply information regarding the position of the R point or regarding the design torso angle, the centroid of the three measured points or the average of the three measured angles shall be used and be regarded as applicable in all cases where the R point or the design torso angle is referred to in this Regulation.
4. PROCEDURE FOR DETERMINING THE H POINT AND THE ACTUAL TORSO ANGLE
- 4.1 The vehicle shall be preconditioned at a temperature of 20° C \pm 10° C, at the manufacturer's discretion, to ensure that the seat material reaches room temperature. If the seat to be checked has never been used, a 70 to 80 kg person or device shall be placed on the seat twice for one minute to flex the cushion and back. At the manufacturer's request, all seat assemblies shall remain unloaded for a minimum period of 30 minutes prior to installation of the 3 DH machine.
- 4.2 The vehicle shall be in the measuring attitude defined in paragraph 2.11 above.
- 4.3 The seat, if adjustable, shall be adjusted first to the rearmost normal driving or riding position, as indicated by the vehicle manufacturer, taking into consideration only the longitudinal adjustment of the seat, excluding seat travel used for purposes other than normal driving or riding positions. Where other

modes of seat adjustment exist (vertical, angular, seat-back, etc.), these will be then adjusted to the position specified by the vehicle manufacturer. For suspension seats, the vertical position shall be rigidly fixed corresponding to a normal driving position as specified by the manufacturer.

- 4.4 The area of the seating position taken up by the 3 DH machine shall be covered by a muslin cotton, of sufficient size and appropriate texture, described as a plain cotton fabric having 18.9 threads per cm² and weighing 0.228 kg/m², or knitted or non-woven fabric having equivalent characteristics.

If the test is performed on a seat outside the vehicle, the floor on which the seat is placed shall have the same essential characteristics² as the floor of the vehicle in which the seat is intended to be used.

- 4.5 Place the seat and back assembly of the 3 DH machine so that the centre plane of the occupant (CPO) coincides with the centre plane of the 3 DH machine. At the manufacturer's request, the 3 DH machine may be moved inboard with respect to the CPO if the 3 DH machine is located so far outboard that the seat edge will not permit levelling of the 3 DH machine.

- 4.6 Attach the foot and lower leg assemblies to the seat-pan assembly, either individually or by using the T-bar and lower leg assembly. The line through the H point sight buttons shall be parallel to the ground and perpendicular to the longitudinal centre plane of the seat.

- 4.7 Adjust the feet and leg positions of the 3 DH machine as follows:

- 4.7.1 Seats for driver and outside front passenger:

- 4.7.1.1 Both feet and leg assemblies shall be moved forward in such a way that the feet take up natural positions on the floor, between the operating pedals if necessary. Where possible the left foot shall be located at approximately the same distance to the left of the centre plane of the 3 DH machine as the right foot is to the right. The spirit level verifying the transverse orientation of the 3 DH machine is brought to the horizontal by readjustment of the seat pan if necessary, or by adjusting the leg and foot assemblies towards the rear. The line passing through the H point sight buttons shall be maintained perpendicular to the longitudinal centre plane of the seat.

- 4.7.1.2 If the left leg cannot be kept parallel to the right leg and the left foot cannot be supported by the structure, move the left foot until it is supported. The alignment of the sight buttons shall be maintained.

² Tilt angle, height difference with a seat mounting, surface texture, etc.

4.7.2 Outboard rear seats:

For rear seats or auxiliary seats, the legs are located as specified by the manufacturer. If the feet then rest on parts of the floor which are at different levels, the foot which first comes into contact with the front seat shall serve as a reference and the other foot shall be so arranged that the spirit level giving the transverse orientation of the seat of the device indicates the horizontal.

4.7.3 Other seats:

The general procedure indicated in paragraph 4.7.1 above shall be followed, except that the feet shall be placed as specified by the vehicle manufacturer.

4.8 Apply lower leg and thigh weights and level the 3 DH machine.

4.9 Tilt the back pan forward against the forward stop and draw the 3 DH machine away from the seat-back using the T-bar. Reposition the 3 DH machine on the seat by one of the following methods:

4.9.1 If the 3 DH machine tends to slide rearward, use the following procedure: allow the 3 DH machine to slide rearward until a forward horizontal restraining load on the T-bar is no longer required, i.e. until the seat pan contacts the seat-back. If necessary, reposition the lower leg.

4.9.2 If the 3 DH machine does not tend to slide rearward, use the following procedure: slide the 3 DH machine rearwards by applying a horizontal rearward load to the T-bar until the seat pan contacts the seat-back (see figure 2 of the appendix to this annex).

4.10 Apply a 100 +/- 10 N load to the back and pan assembly of the 3 DH machine at the intersection of the hip angle quadrant and the T-bar housing. The direction of load application shall be maintained along a line passing through the above intersection to a point just above the thigh bar housing (see figure 2 of the appendix to this annex). Then carefully return the back pan to the seat-back. Care must be exercised throughout the remainder of the procedure to prevent the 3 DH machine from sliding forward.

4.11 Install the right and left buttock weights and then, alternatively, the eight torso weights. Maintain the 3 DH machine level.

4.12 Tilt the back pan forward to release the tension on the back-seat. Rock the 3 DH machine from side to side through a 10° arc (5° to each side of the vertical centre plane) for three complete cycles to release any accumulated friction between the 3 DH machine and the seat.

During the rocking action, the T-bar of the 3 DH machine may tend to diverge from the specified horizontal and vertical alignment. The T-bar must therefore be restrained by applying an appropriate lateral load during the rocking motions. Care should be exercised in holding the T-bar and rocking the 3 DH machine to ensure that no inadvertent exterior loads are applied in a vertical or fore-and-aft direction.

The feet of the 3 DH machine are not to be restrained or held during this step. If the feet change position, they should then be allowed to remain in that attitude.

Carefully return the back pan to the seat-back and check the two spirit levels for zero position. If any movement of the feet has occurred during the rocking operation of the 3 DH machine, they must be repositioned as follows:

Alternately, lift each foot off the floor the minimum necessary amount until no additional foot movement is obtained. During this lifting, the feet are to be free to rotate; no forward or lateral loads are to be applied. When each foot is placed back in the down position, the heel is to be in contact with the structure designed for this.

Check the lateral spirit level for zero position; if necessary, apply a lateral load to the top of the back pan sufficient to level the 3 DH machine's seat pan on the seat.

4.13 Holding the T-bar to prevent the 3 DH machine from sliding forward on the seat cushion, proceed as follows:

- (a) return the back pan to the seat-back,
- (b) alternately apply and release a horizontal rearward load, not to exceed 25 N, to the back angle bar at a height approximately at the centre of the torso weights until the hip angle quadrant indicates that a stable position has been reached after load release. Care should be taken to ensure that no exterior downward or lateral loads are applied to the 3 DH machine. If another level adjustment of the 3 DH machine is necessary, rotate the back pan forward, re-level, and repeat the procedure from 4.12.

4.14 Take all measurements:

4.14.1 The coordinates of the H point are measured with respect to the three-dimensional reference system.

4.14.2 The actual torso angle is read at the back angle quadrant of the 3 DH machine with the probe in its fully rearward position.

4.15 If a repetition of the installation of the 3 DH machine is desired, the seat assembly shall remain unloaded for a minimum period of 30 minutes prior to the repetition. The 3 DH machine shall not be left loaded on the seat assembly longer than the time required to perform the test.

4.16 If the seats in the same row can be regarded as similar (bench seat, identical seats, etc.) only one H point and one actual torso angle shall be determined for each row of seats, the 3 DH machine described in the appendix to this annex being seated in a place regarded as representative for the row.

This place shall be:

4.16.1 In the case of the front row, the driver's seat,

4.16.2 In the case of the rear row or rows, an outer seat.

Annex 3 - Appendix

DESCRIPTION OF THE THREE-DIMENSIONAL H POINT MACHINE³
(3 DH machine)

1. BACK AND SEAT PANS

The back and seat pans are constructed of reinforced plastics and metal; they simulate the human torso and thighs and are mechanically hinged at the H point. A quadrant is fastened to the probe hinged at the H point to measure the actual torso angle. An adjustable thigh bar, attached to the seat pan, establishes the thigh centre line and serves as a baseline for the hip angle quadrant.

2. BODY AND LEG ELEMENTS

Lower leg segments are connected to the seat pan assembly at the T-bar joining the knees, which is a lateral extension of the adjustable thigh bar. Quadrants are incorporated in the lower leg segments to measure knee angles. Shoe and foot assemblies are calibrated to measure the foot angle. Two spirit levels orient the device in space. Body element weights are placed at the corresponding-centres of gravity to provide seat penetration equivalent to a 76 kg male. All joints of the 3 DH machine should be checked for free movement without encountering any noticeable friction.

³ The machine corresponds to that described in ISO Standard 6549-1980.

[For details of the construction of the 3 DH machine refer to Society of Automotive Engineers (SAE), 400 Commonwealth Drive, Warrendale,] Pennsylvania 15096, United States of America.

Figure 1

DESIGNATION OF 3 DH MACHINE COMPONENTS

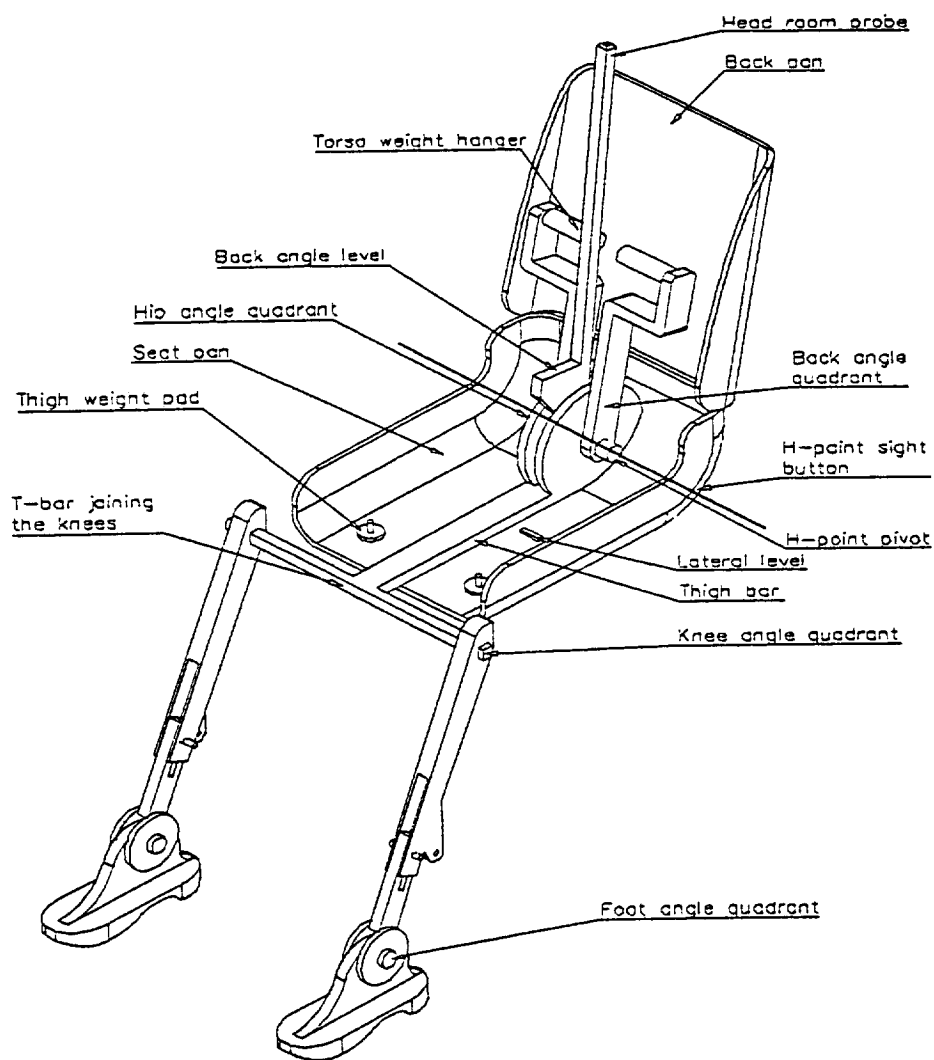
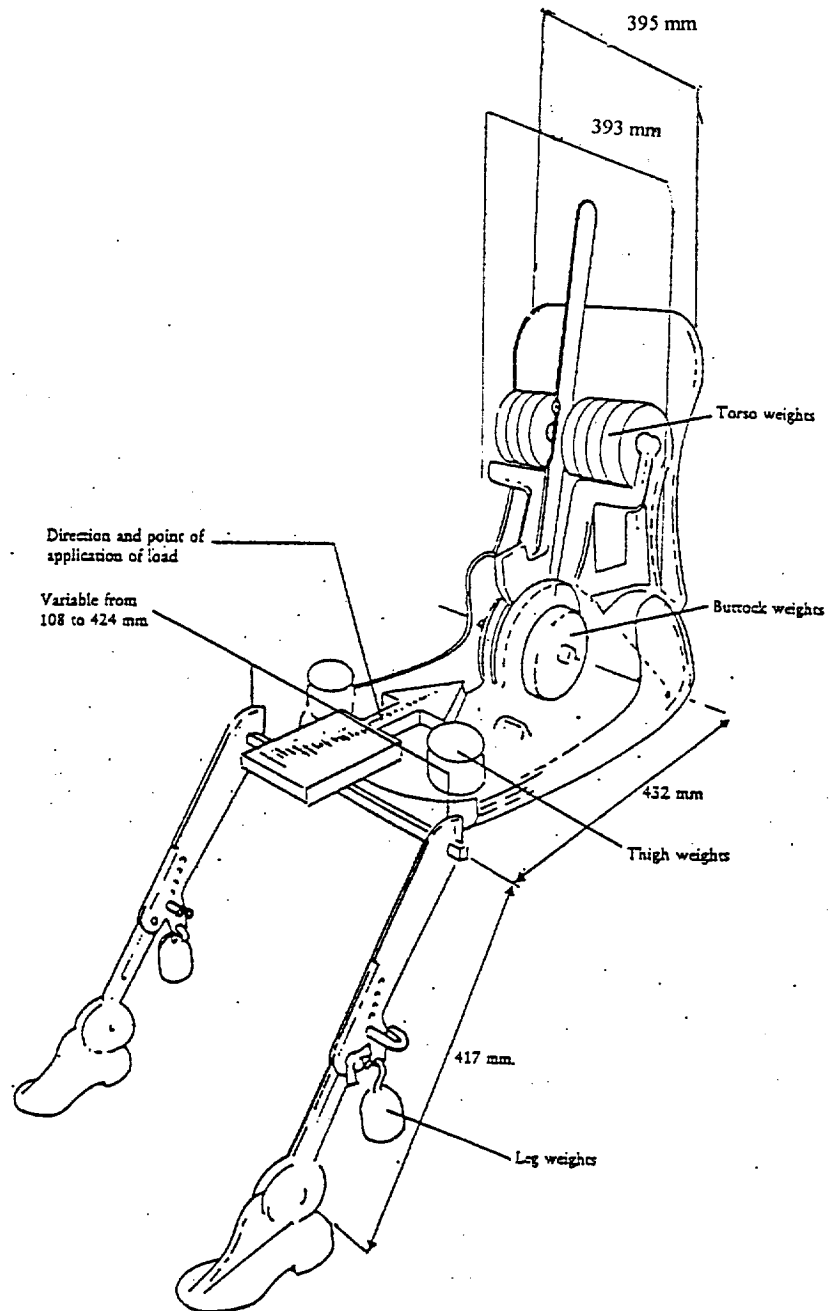

Figure 2

DIMENSIONS OF 3 DH MACHINE COMPONENTS
AND LOAD DISTRIBUTION



Annex 4

METHOD FOR DETERMINING THE DIMENSIONAL RELATIONSHIPS BETWEEN THE VEHICLE'S PRIMARY REFERENCE MARKS AND THE THREE-DIMENSIONAL REFERENCE SYSTEM

1. PURPOSE

This annex describes a method enabling the vehicle to be situated in relation to a reference system. All the coordinates, which refer to a ground zero point, need to be calculated for a vehicle in running order [having on board, in addition to the driver, a passenger with a mass of 75 kg \pm 1%, seated on the front seat].

2. RELATIONSHIP BETWEEN THE REFERENCE SYSTEM AND THE VEHICLE'S PRIMARY REFERENCE MARKS

In order to verify specific dimensions on the inside or the outside of a vehicle, it is necessary to determine accurately the relationship between the coordinates established in the initial vehicle-design stage in the context of the three-dimensional reference grid which has been defined and the position of the primary reference marks, so that specific points on the vehicle manufacturer's drawings can be identified on an actual vehicle constructed in accordance with those drawings.

Figure 4: METHOD FOR DETERMINING THE RELATIONSHIP BETWEEN THE REFERENCE SYSTEM AND THE REFERENCE MARKS

In order to determine this relationship a ground reference plane is established with graduated x and y axes. Figure 4 of the appendix to this annex shows how this should be done. The reference plane comprises a hard, flat, level surface on which the vehicle stands, with two measuring scales firmly fixed on it, graduated in millimetres; the x axis must have a minimum length of 8 metres and the y axis a minimum length of 4 metres. They must be set at right angles to each other. The intersection of these scales is the ground zero point.

Figure 4: EXAMINATION OF THE REFERENCE PLANE

In order to take into account variations in the level of the reference plane or test area, it is essential to measure the deviations from the ground zero point along both x and y axes at intervals of 250 mm, and to record the readings obtained so that the necessary corrections can be made when the vehicle is checked.

Figure 4: ACTUAL CHECKING POSITION

In order to take into account minor variations in suspension height, etc., it is necessary to have a means of bringing the reference marks to the coordinate positions determined at the design stage before further measurements are taken. In addition, it must be possible to make minor lateral and/or longitudinal adjustments to the vehicle's position so as to place it correctly in relation to the reference system.

Figure 4: RESULTS

Once the vehicle is correctly positioned in relation to the reference system and in the position for which the design study provides, the location of the points required for studying the conditions of forward visibility can be readily determined.

In order to determine these requirements, theodolites, light sources or shadow devices can be used, or any other method which can be shown to give equivalent results.

Annex 4 - Appendix 1

THREE-DIMENSIONAL REFERENCE SYSTEM

1. The three-dimensional reference system is defined by three orthogonal planes established by the vehicle manufacturer (see figure).¹
2. The vehicle measuring attitude is determined by positioning the vehicle on a supporting surface such that the coordinates of the fiducial marks correspond to the values indicated by the manufacturer.
3. The coordinates of the R point and the H point are determined in relation to the fiducial marks defined by the vehicle manufacturer.

Figure 3

THREE-DIMENSIONAL REFERENCE SYSTEM

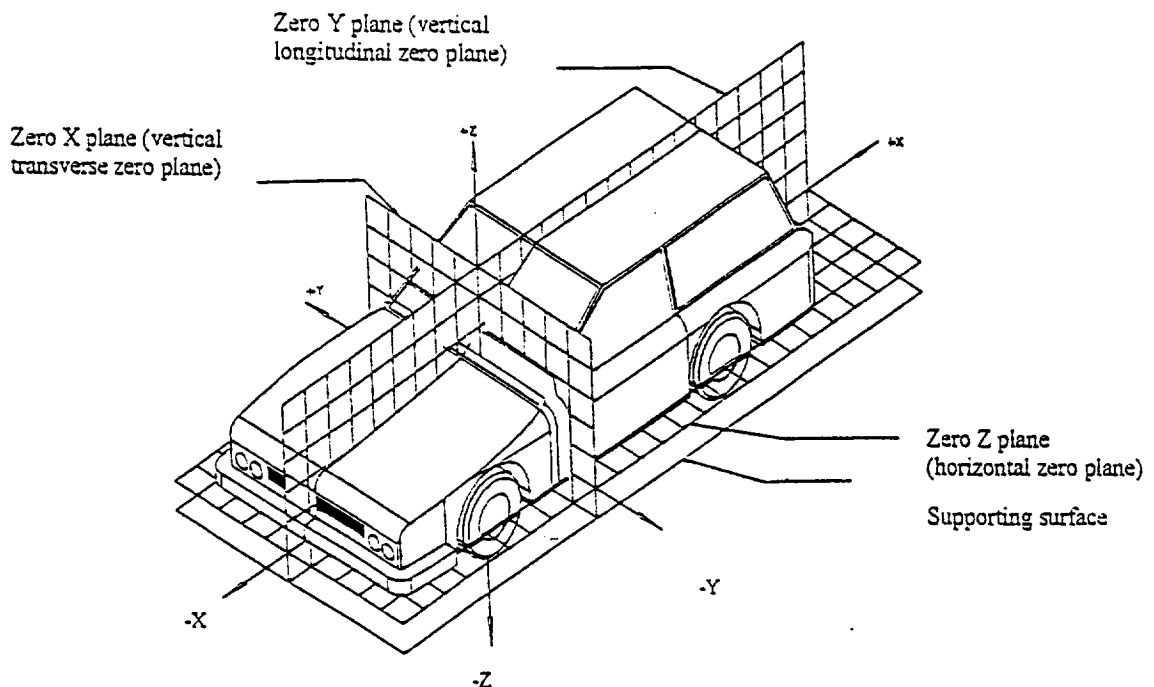

¹ The reference system corresponds to ISO Standard 4130-1978.

Figure 4

WORKING AREA ON THE GROUND

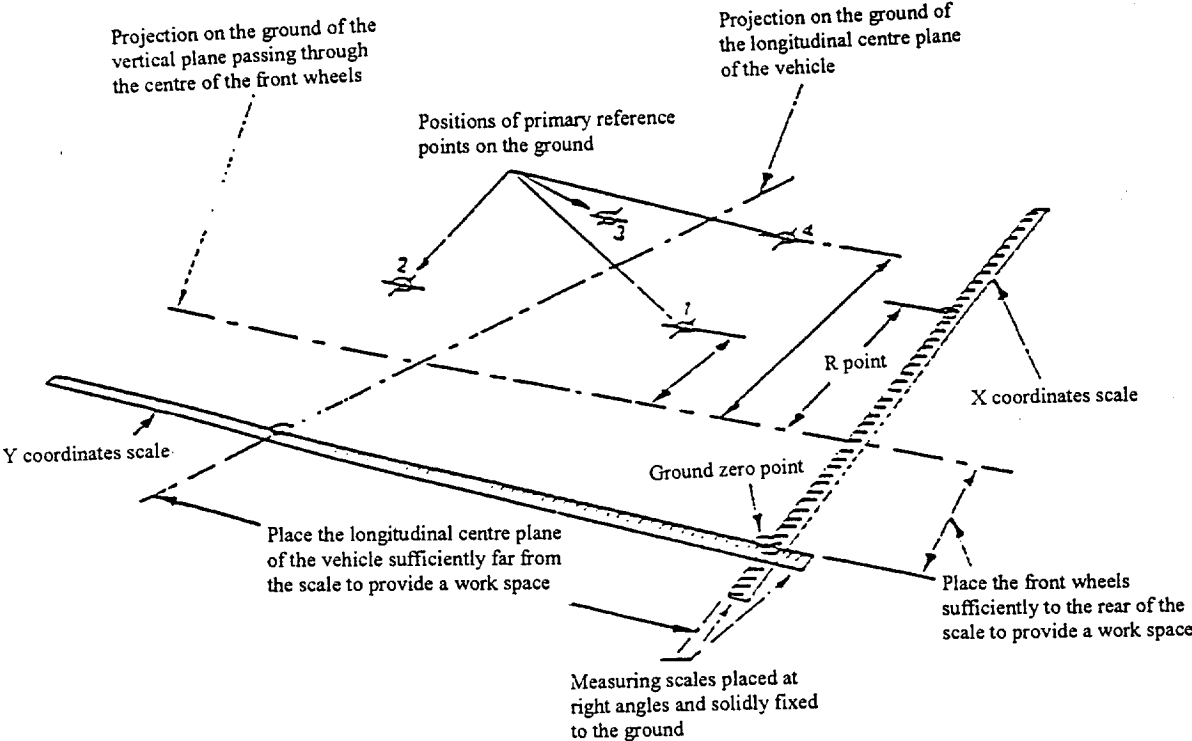

Annex 4 - Appendix 2

REFERENCE DATA CONCERNING SEATING POSITIONS

1. CODING OF REFERENCE DATA

Reference data are listed consecutively for each seating position. Seating positions are identified by a two-character code. The first character is an Arabic numeral which designates the row of seats, counting from the front to the rear of the vehicle. The second is a capital letter which designates the location of the seating position in a row, as viewed in the direction of forward motion of the vehicle; the following letters shall be used:

L = left,
C = centre,
R = right.

2. DESCRIPTION OF VEHICLE MEASURING ATTITUDE

2.1 Coordinates of fiducial marks

X
Y
Z

3. LIST OF REFERENCE DATA

3.1 Seating position:

3.1.1 Coordinates of the R point:

X
Y
Z

3.1.2 Design torso angle:

3.1.3 Specifications for seat adjustment²

horizontal:
vertical:
angular:
torso angle:

Note: List reference data for further seating positions under 3.2, 3.3, etc.

² Strike out what does not apply.

Annex 5

**GEOMETRICAL RELATIONSHIPS BETWEEN THE POSITIONS
OF THE V, P AND E POINTS AND THE R POINT**

1. **PURPOSE**

This annex defines the geometrical relationships between the characteristic points enabling the obstructions to the driver's forward field of vision to be determined. It specifies the corrections to be made in terms of the ranges of horizontal adjustment to the seat and the seat-back angle. The positive direction of the coordinates is indicated in Annex 4, Appendix 1, figure 3.

2. **POSITION OF THE V POINTS**

- 2.1 The V points are determined on the basis of the R point of the driver's seating position, taking into account the x, y and z coordinates, as they appear in tables I and IV. Table I indicates the basic coordinates for a design seat-back angle of 25°.

TABLE I

V point	X	Y	Z
V ₁	68 mm	- 5 mm	665 mm
V ₂	68 mm	- 5 mm	589 mm

- 2.1.2 Table IV enables coordinates to be adapted in terms of seat-back angles other than 25°.

3. **POSITION OF THE P POINTS**

- 3.1 The P points are determined on the basis of the R point of the driver's seating position, taking into account their x, y and z coordinates as they appear in tables II, III and IV.

- 3.1.1 Table II indicates the basic coordinates for a design seat-back angle of 25°. Point P_m is the point of intersection between the straight line joining P₁ and P₂ and the longitudinal vertical plane passing through the R point.

TABLE II

P point	x	y	z
P ₁	35 mm	- 20 mm	627 mm
P ₂	63 mm	47 mm	627 mm
P _m	43.36 mm	0 mm	627 mm

- 3.1.2 Table III gives the additional corrections to be made to the x coordinates of P₁ and P₂ when the range of horizontal adjustment of the seat, according to the definition given in paragraph 2.11, exceeds 108 mm.

TABLE III

Range of horizontal adjustment of seat	Δx
108 to 120 mm	-13 mm
121 to 132 mm	-22 mm
133 to 145 mm	-32 mm
146 to 158 mm	-42 mm
more than 158 mm	-48 mm

4. CORRECTIONS

Table IV indicates the adjustments to be made to the x and z coordinates of each P and V point when the design seat-back angle is not 25°.

TABLE IV

Seat-back angle (degrees)	Horizontal coordinates Δx	Vertical coordinates Δz	Seat-back angle (degrees)	Horizontal coordinates Δx	Vertical coordinates Δz
5	- 186 mm	28 mm	23	- 18 mm	5 mm
6	- 177 mm	27 mm	24	- 9 mm	3 mm
7	- 167 mm	27 mm	25	0 mm	0 mm
8	- 157 mm	27 mm	26	9 mm	- 3 mm
9	- 147 mm	26 mm	27	17 mm	- 5 mm
10	- 137 mm	25 mm	28	26 mm	- 8 mm
11	- 128 mm	24 mm	29	34 mm	- 11 mm
12	- 118 mm	23 mm	30	43 mm	- 14 mm
13	- 109 mm	22 mm	31	51 mm	- 18 mm
14	- 99 mm	21 mm	32	59 mm	- 21 mm
15	- 90 mm	20 mm	33	67 mm	- 24 mm
16	- 81 mm	18 mm	34	76 mm	- 28 mm
17	- 72 mm	17 mm	35	84 mm	- 32 mm
18	- 62 mm	15 mm	36	92 mm	- 35 mm
19	- 53 mm	13 mm	37	100 mm	- 39 mm
20	- 44 mm	11 mm	38	108 mm	- 43 mm
21	- 35 mm	9 mm	39	115 mm	- 48 mm
22	- 26 mm	7 mm	40	123 mm	- 52 mm

5. POSITION OF E POINTS

- 5.1 The E_1 and E_2 points are each located at a distance of 104 mm from P_1 . E_2 is situated at a distance of 65 mm from E_1 according to the principle set out in figure 5 below.
- 5.2 E_3 and E_4 are each located 104 mm from P_2 . E_3 is located 65 mm from E_4 .

Figure 5
POSITION OF E POINTS

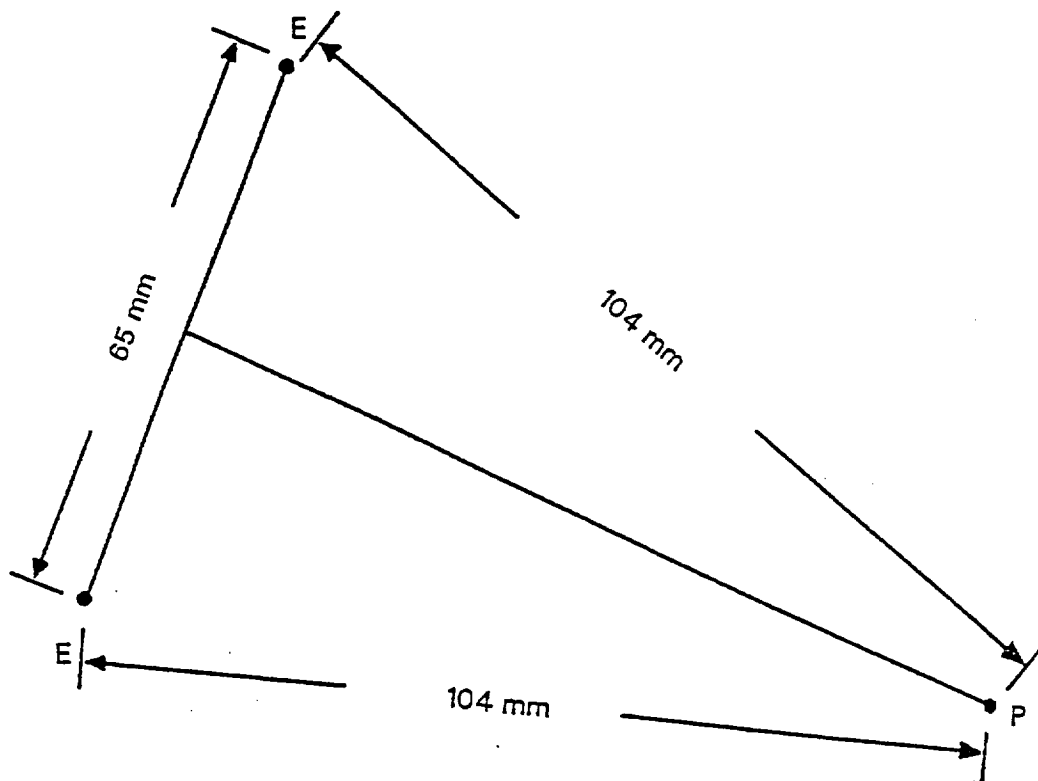

Annex 5 - Appendix I

Figure 6

DETERMINATION OF THE V POINTS

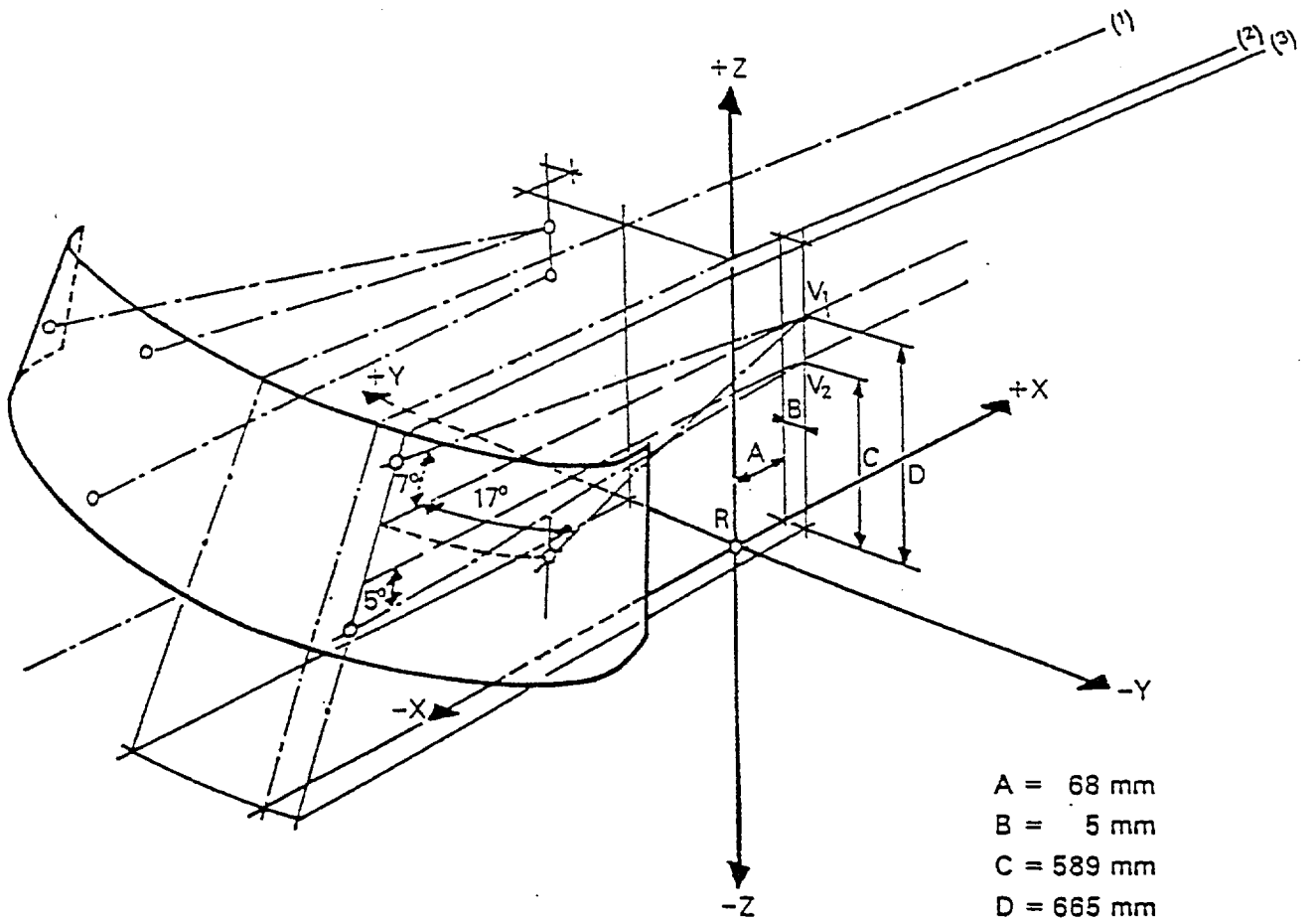

-
- (1) Line tracing the median longitudinal plane of the vehicle.
 - (2) Line tracing the vertical plane passing through R.
 - (3) Line tracing the vertical plane passing through V_1 and V_2 .
-

Annex 5 - Appendix 2

VERIFICATION AREA

Figure 7

AREA IN WHICH THE SPECIFICATIONS OF
PARAGRAPH 5.1.3 ARE APPLICABLE

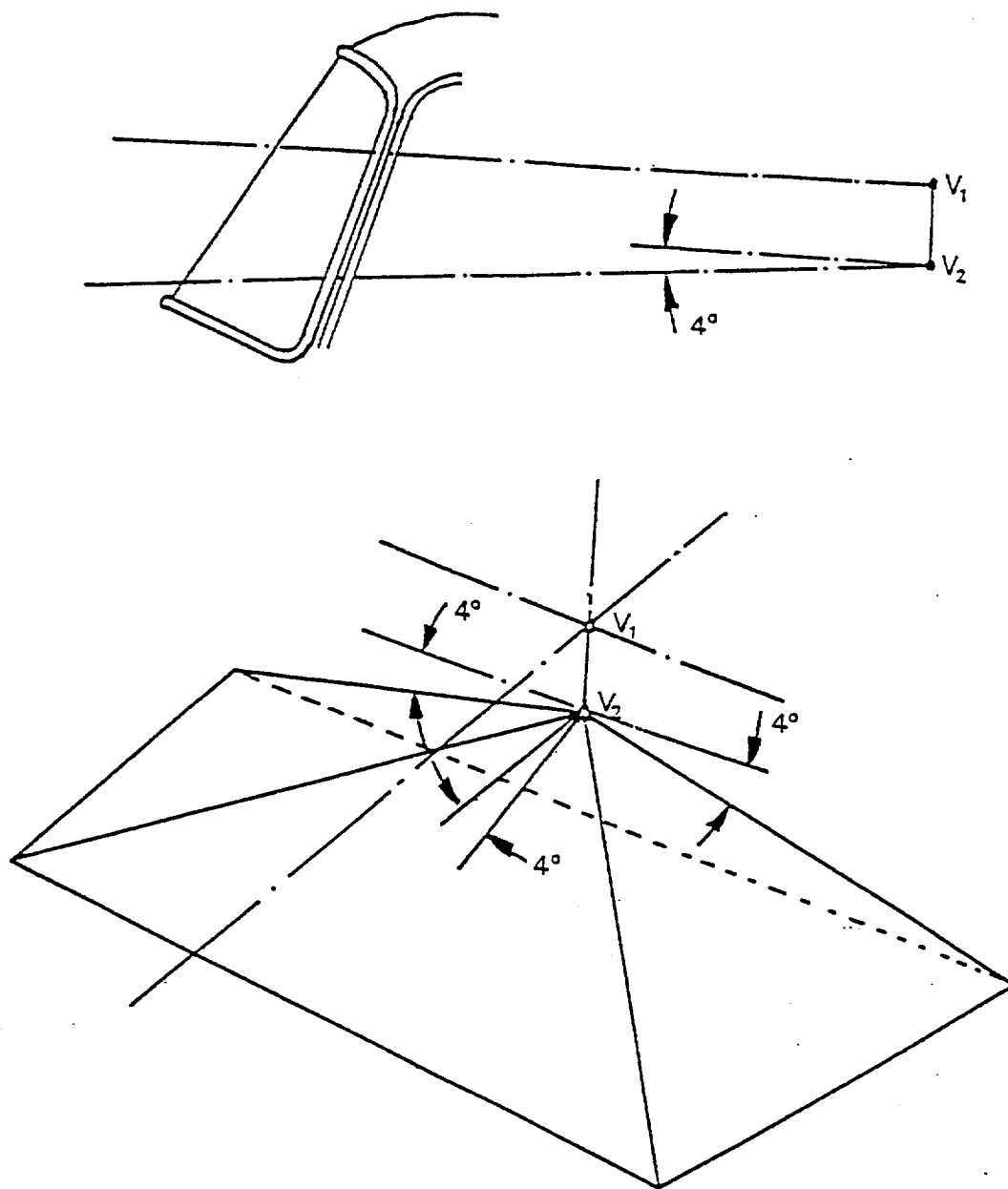

Annex 5 - Appendix 3

DETERMINATION OF THE ANGLES OF OBSTRUCTION OF THE A PILLARS

PRINCIPLE

Two sections S_1 and S_2 are made from point P_m as indicated in figure 8.

The line joining E_1 and E_2 is rotated about P_1 until the tangent from E_1 to the outer edge of section S_2 of the A pillar on the driver's side forms an angle of 90° with the straight line E_1-E_2 (see figure 9).

The line joining E_3 and E_4 is rotated about P_2 until the tangent from E_4 to the outer edge of section S_2 of the A pillar on the passenger side forms an angle of 90° with the straight line E_3-E_4 (see figure 9).

The angles thus obtained are measured and compared with the limit value.

Figure 8

OBSERVATION POINTS OF THE A PILLARS

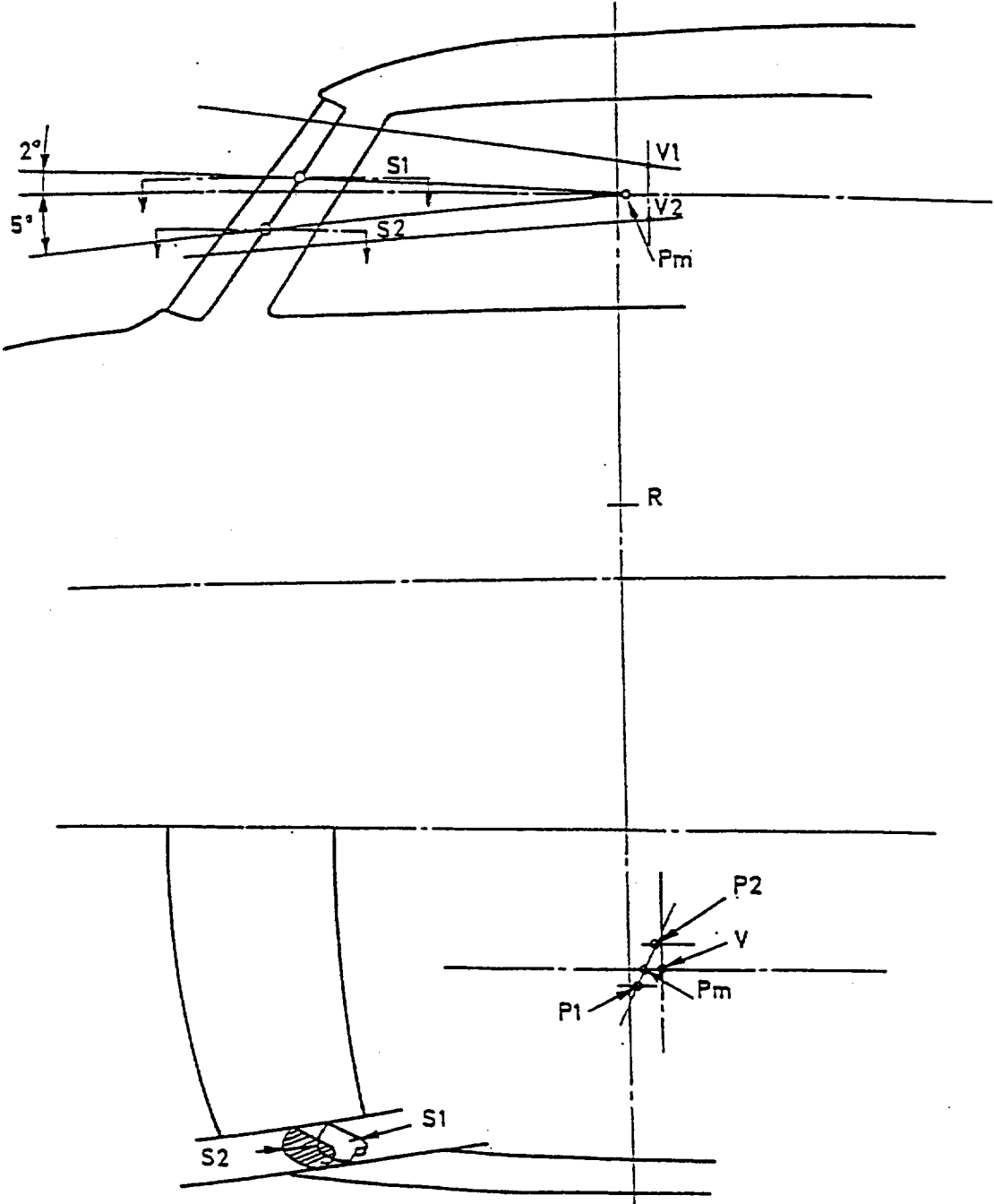

Figure 9
ANGLES OF OBSTRUCTION

