

# BUSES FOR CARRYING CHILDREN

## Russian requirements



## 1 Scope

This standard applies to special vehicles of M2 and M3 categories in accordance with the Consolidated Resolution on the Construction of Vehicles (RE.3) designed for carrying children aged **1.5** to **16** years on public roads.

## 2 Technical requirements

### General provisions:

General requirements for construction of buses — **UN Regulation No. 107** — UN Regulation **No. 52**.

When determining the weight of buses, the following weight restrictions shall be considered:

- child — 40 kg;
- adult passenger — 75 kg;
- hand luggage — 5 kg per passenger;
- luggage carried — 5 kg per one child and 10 kg — per one passenger;
- wheelchairs — 20 kg.

## General requirements

The maximum design speed shall not exceed **60 km/h**, buses must be equipped with a speed limitation device in accordance with the requirements of UN Regulation No. 89.

The front and rear of the buses shall be marked with the signs “Carriage of children”.

On the outer sides of the bus body, as well as on the front and rear along the axis of symmetry of the bus, contrasting inscriptions “CHILDREN” («ДЕТИ») shall be applied in upright capital letters with a height of **at least 250 mm** and a thickness of at least **one tenth** of their height.

The body of the bus **shall have yellow colour painting**. The recommended shade of yellow is RAL1023 according to the RAL Classic colour catalog.

The bus manufacturer shall provide for **the frequency of inspection**, adjustment and maintenance of mechanisms, components and parts that determine the safety of the bus operation (steering, braking system, tyres, fire extinguishers, emergency exit control mechanisms, etc.), **halved** compared to the bus, on the base of which the bus was manufactured, **or not more than 10,000 km mileage** for buses manufactured on the original base. The corresponding instruction shall be put in the operational documentation for the bus.

# ДЕТИ



## Requirements for the seats

At the manufacturer's discretion buses may be equipped with child seats and/or seats designed to accommodate child restraints, which can be equipped with ISOFIX child restraint mounting systems.

The dimensions and arrangement of the seats are shown in the figure.

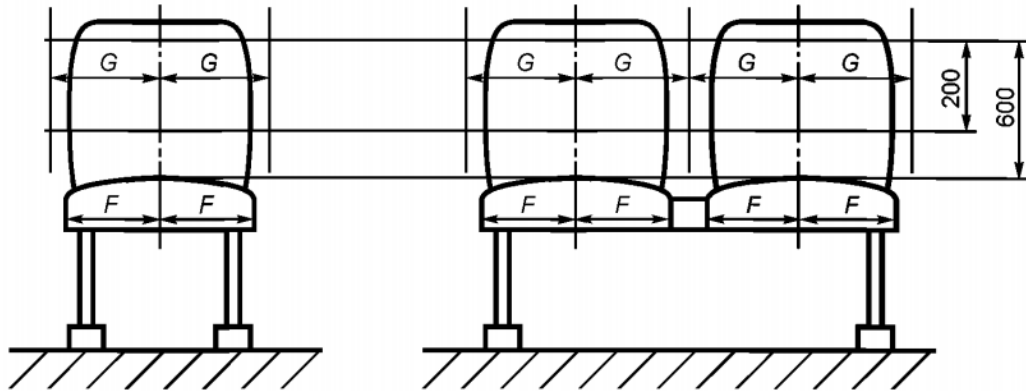

For child seats **without ISOFIX**,  $H$  shall be at least 600 mm.

For child seats **with ISOFIX**,  $H$  shall be at least 750 mm.

For child seats **without ISOFIX**, the width  $2F$  of seat cushion shall be at least 320 mm.

For child seats **with ISOFIX**, the width  $2F$  of seat cushion shall be at least 450 mm, and the height of the backrest – at least 750 mm, measured from non-deformed seat cushion.

For child seats **without ISOFIX**,  $G$  shall be at least 170 mm.

For child seats **with ISOFIX**,  $G$  shall be at least 250 mm.

For child seats **without ISOFIX**,  $K$  shall be at least 350 mm.

For child seats **with ISOFIX**,  $K$  shall be at least 400 mm.

For child seats **without ISOFIX**,  $I$  shall be between 350 and 400 mm.

For child seats **with ISOFIX**,  $I$  shall be between 400 and 450 mm.

$B$  shall be  $180 \pm 20$  mm.

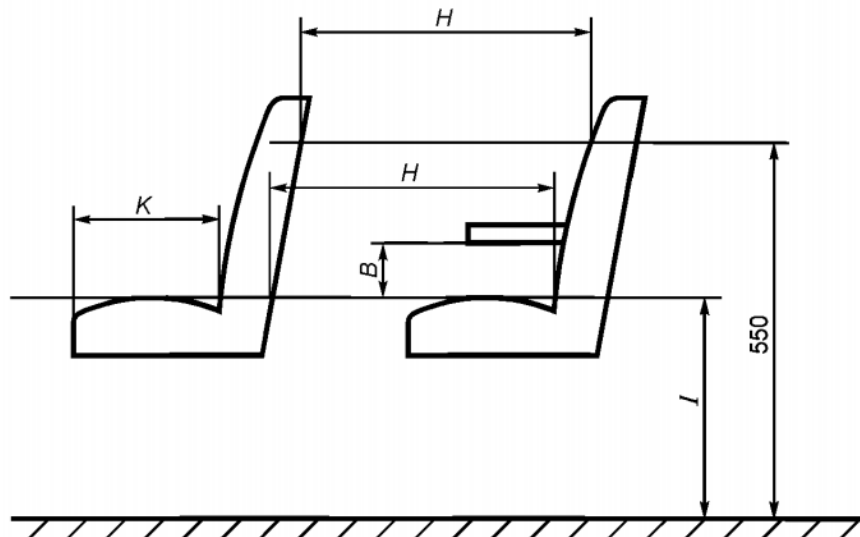

**Child seats** with regard to their strength properties **shall be tested** according to the methodology described in **UN Regulation No. 80** under the test load:

- **1180 N**, applied to the seatback at a height of 0.75 m above the reference plane. The displacement of the central point of the load application shall be not less than 100 mm and not more than 400 mm;
- **3140 N** applied to the seatback at a height of 0.45 m above the reference plane. The displacement of the central point of the load application shall be not less than 50 mm.

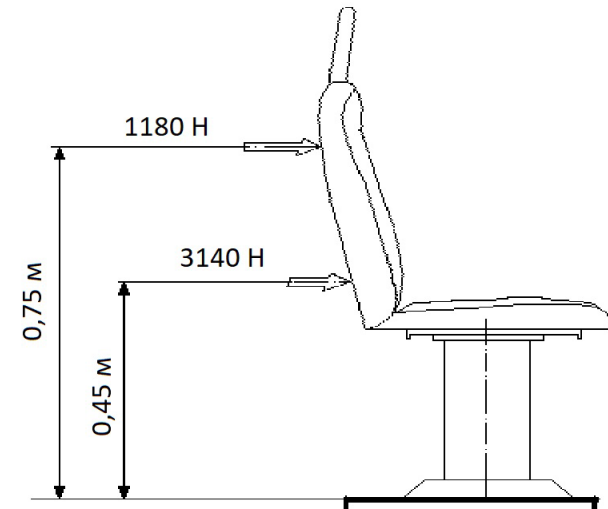

Child seats shall be equipped with restraint systems.

These systems incorporate **seat belts of ZS or ZSr4m type** in accordance with the requirements of **UN Regulation No. 16**.

The use of **child restraint systems complying with the requirements of UN Regulation No. 44** is also permitted.

The strength of the seatbelt anchorages is assessed in accordance with **UN Regulation No. 14**.

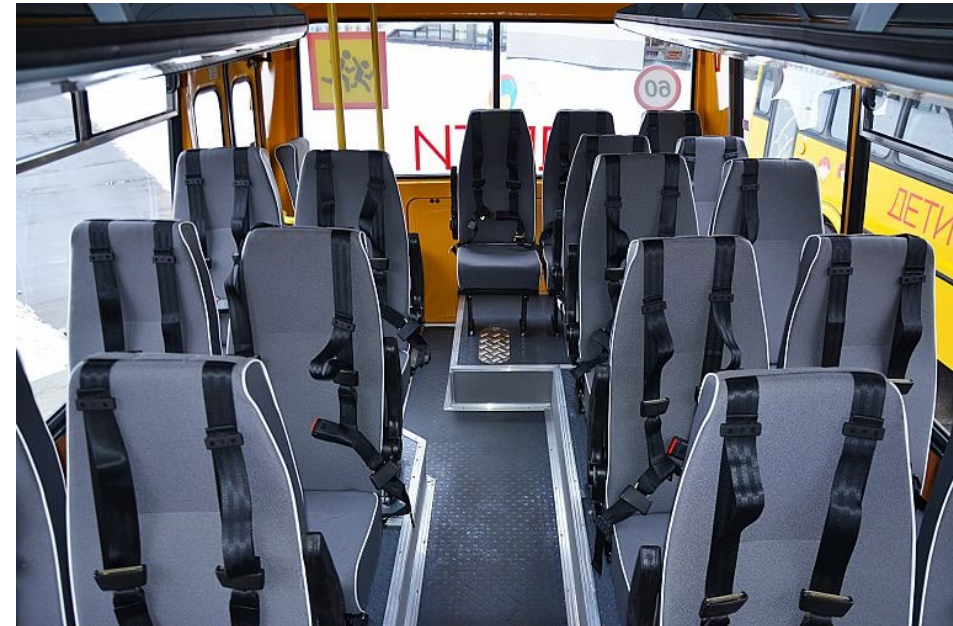



**Thank you for your attention  
Ready to answer your  
questions**

Inquiries are to be addressed to:  
Gleb Nevsky  
Head of the PSL VSF NITZIAMT FSUE “NAMI”  
E-mail: [g.nevskiy@autorc.ru](mailto:g.nevskiy@autorc.ru)

