

**Economic and Social Council**Distr.: General  
22 February 2019

Original: English

---

**Economic Commission for Europe****Inland Transport Committee****World Forum for Harmonization of Vehicle Regulations****Working Party on Passive Safety****Sixty-fifth session**

Geneva, 13-17 May 2019

Item 2 of the provisional agenda

**UN Global Technical Regulation No. 7 (Head Restraints)****Proposal for Amendment 1 (Phase 2) to UN Global Technical Regulation No. 7 (Head Restraints)****Submitted by the expert from the European Association of Automotive Suppliers \***

The text below was prepared by the expert from the European Association of Automotive Suppliers (CLEPA) to amend the static options of the proposal of amendment 1 of UN Global Technical Regulation No. 7 submitted by the Informal Working Group on the Phase 2 of UN GTR No. 7 (ECE/TRANS/WP.29/GRSP/2018/27). It is based on informal document GRSP-64-25, distributed at the sixty-fourth session of the Working Party on Passive Safety (GRSP), which is also relevant for the Phase 2 of the GTR. The modifications to ECE/TRANS/WP.29/GRSP/2018/27, are marked in bold or strikethrough characters.

---

\* In accordance with the programme of work of the Inland Transport Committee for 2018–2019 (ECE/TRANS/274, para. 123 and ECE/TRANS/2018/21/Add.1, Cluster 3.1), the World Forum will develop, harmonize and update UN regulations to enhance the performance of vehicles. The present document is submitted in conformity with that mandate.

GE.19-03065(E)



\* 1 9 0 3 0 6 5 \*

Please recycle The recycling symbol, consisting of three chasing arrows forming a triangle.



## I. Proposal

*Paragraph 5.1.1.4., amend to read:*

"5.1.1.4. Exception

If the interior surface of the vehicle roofline, including the headliner, physically prevents a head restraint, located in the front designated seating position, from attaining the height required by paragraphs 5.1.1.2. ~~and~~ or 5.1.1.3. of this Regulation as applicable, the gap between the head restraint and the interior surface of the roofline, including the headliner, when measured in accordance with Annex 1 paragraph 2.3.3.1., shall not exceed 50 mm when the head restraint is adjusted to its highest position intended for occupant use. However, in no instance shall the height of a head restraint located in a front ~~outboard~~ designated seating position be less than 700 mm when the head restraint is adjusted to its lowest position intended for occupant use."

*Paragraph 5.2.1., amend to read:*

"5.2.1. Energy absorption

When the front surface of the head restraint is impacted in accordance with Annex 7, the deceleration of the head form shall not exceed  $785 \text{ m/s}^2$  (80g) continuously for more than 3 milliseconds. ~~Moreover, no dangerous edge shall occur during or remain after the test."~~

*Paragraph 5.4.4.2., amend to read:*

"5.4.4.2. In front centre and rear designated seating positions equipped with head restraints, the head restraint shall, when tested in accordance with Annex 10, be capable of manually rotating either forward or rearward by not less than  $60^\circ$  from any position of adjustment intended for occupant use in which its minimum height is not less than that specified in paragraph 5.1.1. of this Regulation. **A head restraint rotated by minimum of  $60^\circ$  forward or rearward, is considered to be placed in a non-use position even if the head restraint height in such a position would be greater than that specified in paragraph 5.1.1.**"

*Paragraph 5.4.4.5., amend to read:*

"5.4.4.5. The **presence of a non-use position of a** head restraint shall be marked with a label in the form of a pictogram which may include explanatory text. The label shall either provide an indication when the head restraint is in a non-use position or provide information to enable an occupant to determine whether the head restraint is in a non-use position. The label shall be durably affixed and located such that it is clearly visible by an occupant when entering the vehicle to the designated seating position. **The number of labels is not requested to exceed the number of head restraints with non-use positions.** Examples of possible designs of pictograms are shown in Figure 1."

*Annex 2, paragraph 2.1., amend to read:*

"2.1. The seat shall be adjusted such that its H-point coincides with the R-point; if the seat back is adjustable, it is set at the design seat back angle; both these adjustments shall be in accordance with the requirements of paragraph 2.1. of Annex 1.

**The head restraint shall be adjusted to its highest and most rearward position relative to the seat back."**

Annex 3, paragraph 2.3., amend to read:

"2.3. The area of measurement is anywhere between two vertical longitudinal planes passing at 85 mm on either side of the torso line and above ~~the top of the seat back~~ **a height of 540 mm.**"

Annex 3, paragraph 2.5., amend to read:

"2.5. Determine the gap dimension by measuring the straight line distance between the inner edges of the two furthest contact points, as shown in Figures 3-1, ~~and 3-2 and 3-3.~~"

Annex 3, insert a new Figure 3-3, to read:

"Figure 3-3

**Portion of gap above 540mm.**

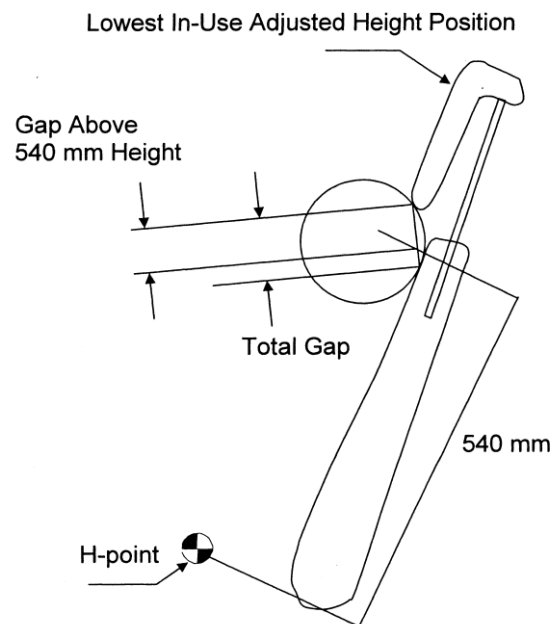

"

Annex 3, paragraph 3.3., amend to read:

"3.3. The gap between the bottom of the head restraint and the top of the seat is measured as the perpendicular distance between two parallel planes, described as follows (see Figure 3-~~34~~):"

Annex 3, Figure 3-3 (former), renumber as Figure 3-4

Annex 6, paragraphs 2.3. and 2.4., amend to read:

"2.3. Establish the displaced torso reference line 'r1' by creating a rearward moment of  $373 \pm 7.5$  Nm about the R-point by applying a force to the seat back through the back pan at the rate of **[2.5 Nm/second to 37.3 Nm/second]**. The initial location on the back pan of the moment generating force vector has a height of  $290 \text{ mm} \pm 13 \text{ mm}$ . Apply the force vector normal to the torso reference line and maintain it within 2 degrees of a vertical plane parallel to the vehicle longitudinal centreline. Constrain the back pan to rotate about the R-point. Rotate the force vector direction with the back pan. **In the case of simultaneous testing of bench seats, the rear ward moment shall be**

**applied to all seating positions of the bench simultaneously, irrespective of this position being equipped with or without head restraint.**

- 2.4. Maintain the position of the back pan as established in paragraph 2.3. of this Annex. Using a  $165 \pm 2$  mm diameter spherical headform establish the headform initial reference position by applying, perpendicular to the displaced torso line, a rearward initial load at the seat centreline at a height  $65 \pm 3$  mm below the effective top of the head restraint that will produce a 373 Nm moment about the R-point. Maintain this moment for at least 5 seconds and then record the rearward displacement of the headform with the load applied. **In the case of simultaneous testing of bench seats, the force shall be applied to all head restraints as present on the bench seats simultaneously."**

*Annex 6, paragraph 3.,* renumber as paragraphs 3 to 3.4 and amend to read:

- "3. Procedures for backset retention and displacement
- 3.1.** If the seat back is adjustable, it is adjusted to a position specified by the vehicle manufacturer. If there is more than one inclination position closest to the position specified by the manufacturer, set the seat back inclination to the position closest to and rearward of the manufacturer specified position. If the head restraint position is independent of the seat back inclination position, compliance is determined at a seat back inclination position specified by the manufacturer. Adjust the head restraint to the highest position of vertical adjustment intended for occupant use.
- 3.2.** Adjust the head restraint to [any] backset position.
- 3.3.** In the seat, place a test device having the back pan dimensions and torso line (vertical centre line), when viewed laterally, with the head room probe in the full back position, of the three-dimensional H-point machine.
- 3.4.** Establish the displaced torso line by creating a rearward moment of  $373 \pm 7.5$  Nm about the R-point by applying a force to the seat back through the back pan at the rate between **[2.5 Nm/second and 37.3 Nm/second]**. The initial location on the back pan of the moment generating force vector has a height of  $290 \text{ mm} \pm 13 \text{ mm}$ . Apply the force vector normal to the torso line and maintain it within 2 degrees of a vertical plane parallel to the vehicle longitudinal centreline. Constrain the back pan to rotate about the R-point. Rotate the force vector direction with the back pan."

*Annex 6, paragraphs 3.7. and 3.8.,* amend to read:

- "3.7. Increase the initial load at the rate of **[2.5 Nm/second to 37.3 Nm/second]** until a 373 Nm moment about the R-point is produced. Maintain the load level producing that moment for not less than 5 seconds and then measure the rearward displacement of the headform relative to the displaced torso line.
- 3.8. Reduce the load at the **rate of [2.5 Nm/second to 37.3 Nm/second]** until 0 Nm. Wait **not more than 10 2** minutes. Re-load to  $37 \pm 0.7$  Nm about the R-point. While maintaining the load level producing that moment, measure the rearward displacement of the headform position with respect to its initial reference position."

*Annex 6, paragraph 4,* amend to read:

- "4. Strength
- Increase the load specified in paragraph 2.6. or paragraph 3.8. of this Annex at the rate **[5 N/second and 200 N/second]** to at least 890 N and maintain the applied

load for not less than 5 seconds"

Annex 7, paragraph.3.1.1., amend to read:

"3.1.1. Use an impactor with a semispherical headform of a  $165 \pm 2$  mm diameter. The headform and associated base have a combined mass such that at a speed of ~~not more than~~ 24.1 km/h at the time of impact an energy of 152 Joule will be reached."

Annex 8, insert a new paragraph 2.10., to read:

**"2.10. Alternatively, when the manufacturer demonstrates that the difference of the reference positions of the cylinder measured in paragraphs 2.3 and 2.6 of this Annex is smaller than the value required by paragraph 5.2.2. of the Regulation, then the test result will also comply to paragraph 5.2.2. of the Regulation. In this case measurements of 2.4. and 2.7. of Annex 8 do not need to be recorded."**

Annex 10, figure 10-1., amend to read:

"Figure 10-1

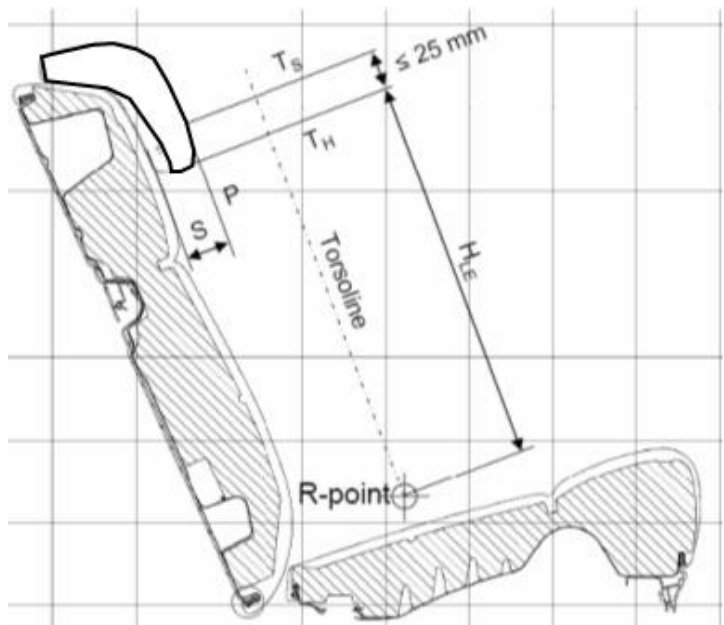

## II. Justification

1. When the experts from CLEPA started to apply the draft UN GTR No. 7 Phase 2, they experienced different ways to apply the proposed amendments which made it necessary to add some clarifications.
2. CLEPA believes that paragraph 5.2.1. is a copy error from UN Regulation No. 17 and removed the erroneous sentence on dangerous edges.
3. In addition, the gap measurement procedure by the sphere was modified in the Federal Motor Vehicle Safety Standard 202a to consider only gaps in the area over 540mm. This proposal adds the proposed area where the gap is considered for the sphere method.