

Proposal for amendments (marked in red) to the

Consolidated Resolution on the Construction of Vehicles (R.E.3)

Content, amend to read:

“Contents

	Page
Resolution	
Preamble.....	3
Introduction	4
1. Definitions of vehicles	5
2. Classification of power-driven vehicles and trailers	6
3. Scope of UN Regulations annexed to the 1958 Agreement	14
4. Active safety requirements.....	35
5. Passive safety requirements	36
6. Requirements for the protection of the environment.....	37
7. General safety requirements.....	38
8. Recommendations	39
Annexes	
1 Standard annex on the procedure for determining the "H" point and the actual torso angle for seating positions in motor vehicles	75
Appendix 1 - Description of the three-dimensional "H" point machine (3-D H machine).....	81
Appendix 2 - Three-dimensional reference system	84
Appendix 3 - Reference data concerning seating positions.....	85
2 Guidelines on measures ensuring the audibility of hybrid and electric vehicles	86
3 Distinguishing number of Contracting Parties to the 1958 agreement in the approval mark	88
4 Recommendation on market fuel quality	89
Appendix 1 - Evolution of the UNECE emission limits	95
Appendix 2 - Evolution of stringency of gasoline market fuel quality standards	96
Appendix 3 - Correlation between UN Regulations and Euro standards	98
Appendix 4 - Housekeeping.....	99
5 Design principles for Control Systems of Advanced Driver Assistance System (ADAS).....	100
Appendix - Human-Machine Interaction (HMI) - Considerations for control systems of ADAS.....	106
6 Guideline on cybersecurity and data protection	114”

Preamble

The World Forum for Harmonization of Vehicle Regulations,

Desiring to establish the greatest uniformity in the UN Regulations, rules and recommendations relating to the construction of vehicles, to improve road safety and the protection of the environment, and to facilitate international road traffic and trade in vehicles and their equipment and parts,

Bearing in mind that the provisions of the Convention on Road Traffic of Vienna, 8 November 1968 and of the European Agreements supplementing that Convention provide the basis for harmonization of the performance requirements,

Bearing in mind also that the provisions of the Agreement concerning the Adoption of Uniform Technical Prescriptions for Wheeled Vehicles, Equipment and Parts, which can be Fitted and/or be Used on Wheeled Vehicles and the Conditions for Reciprocal Recognition of Approvals Granted on the Basis of these Prescriptions, done at Geneva on 20 March 1958 ("1958 Agreement") provides further possibilities for harmonization,

Bearing in mind that the Special Resolution No. 1 concerning the common definitions of vehicle categories, masses and dimensions (S.R.1)¹ setting forth common definitions, to be used in the global technical regulations established under the framework of the Agreement concerning the establishing of global technical regulations for wheeled vehicles, equipment and parts which can be fitted and/or be used on wheeled vehicles, done in Geneva on 25 June 1998 ("1998 Agreement"), does not apply to the UN Regulations annexed to the 1958 Agreement,

Noting that the application of the provisions of the 1958 Agreement still leave open the possibility of divergences between one country and another as regards some issues when they establish domestic rules for vehicles design and for the protection of the environment,

Recommends Governments, in order to eliminate these divergences as far as possible, to align their domestic legislation with the recommendations of the Consolidated Resolutions and the provisions of the above-mentioned Agreements, applying them forthwith to the fullest extent possible.

¹ TRANS/WP.29/1045 as amended by ECE/TRANS/WP.29/1045/Amend.1

Introduction

The text hereafter updates the recommendations of the Consolidated Resolution on the Construction of Vehicles and provides information on the legal texts under the framework of the 1958 Agreement (UN Regulations, Rules and specific requirements) applicable in the vehicle design, aiming the improvement of safety and the protection of the environment.

Paragraphs 1. and 2. contain general definitions and the classification used in the documents referred. Paragraph 3. indicates the scope of the UN Regulation(s) and Rule(s). Tables of paragraphs 4. to 7. contain the main requirements for the construction of vehicles so far established and already included into UN Regulation(s) and Rule(s) by the World Forum. Similar requirements are grouped. For any requirement or group of requirements, references are made to the relevant UN Regulations, identified by the number allocated to them by the 1958 Agreement, to the still valid recommendations reproduced in paragraph 8. and to the standard annexes to UN Regulations reproduced in annexes to this Resolution. Annex 3 includes, as complementary information, an updated list of the distinguishing numbers allocated to Contracting Parties by the 1958 Agreement. Annex 4 includes the recommendation on market fuel quality, Annex 5 contains the design principles for control systems of Advanced Driver Assistance Systems (ADAS), Annex 6 contains the guideline on cybersecurity and data protection.

1. Definitions of vehicles²

- 1.1. "*Power-driven vehicle*" means any self-propelled road vehicle, other than a moped in the territories of Contracting Parties which do not treat mopeds as motor cycles, and other than a rail-borne vehicle.
- 1.2. "*Motor vehicle*" means any power-driven vehicle which is normally used for carrying persons or goods by road or for drawing, on the road, vehicles used for the carriage of persons or goods. This term embraces trolley-buses, that is to say, vehicles connected to an electric conductor and not rail-borne. It does not cover vehicles such as agricultural tractors, which are only incidentally used for carrying persons or goods by road or for drawing, on the road, vehicles used for the carriage of persons or goods.
- 1.3. "*Motor cycle*" means any two-wheeled vehicle, with or without side-car, which is equipped with a propelling engine. Contracting Parties may also treat as motor cycles in their domestic legislation three-wheeled vehicles whose unladen mass does not exceed 400 kg. The term "motor cycle" does not include mopeds, although Contracting Parties may treat mopeds as motor cycles for the purpose of the Convention.
- 1.4. "*Moped*" means any two-wheeled or three-wheeled vehicle which is fitted with an internal combustion engine having a cylinder capacity not exceeding 50 cm³ and a maximum design speed not exceeding 50 km per hour.
- 1.5. "*Trailer*" means any non-self propelled vehicle, which is designed and constructed to be towed by a power driven vehicle and includes semi-trailers.
- 1.6. "*Combination of vehicles*" means coupled vehicles which travel on the road as a unit.
- 1.7. "*Articulated vehicle*" means a combination of vehicles comprising a motor vehicle and semi-trailer coupled to the motor vehicle.
- 1.8. "*Road tractor*" means road motor vehicle designed, exclusively or primarily, to haul other road vehicles which are not power-driven (mainly semi-trailers).
- 1.9. "*Agricultural tractor*" means a vehicle specifically designed to deliver a high tractive effort at slow speeds, for the purposes of hauling a trailer or machinery.
- 1.10. "hybrid motor vehicle" means a vehicle with at least two different energy converters and two different energy storage systems (on-vehicle) for the purpose of vehicle propulsion;
- 1.11. "hybrid electric vehicle" means a hybrid vehicle that, for the purpose of mechanical propulsion, draws energy from both of the following on-vehicle sources of stored energy/power:
- a consumable fuel,
 - an electrical energy/power storage device (e.g. battery, capacitor, flywheel/generator, etc.);

² According to the Convention on Road Traffic of Vienna, 8 November 1968 and of the European Agreements supplementing that Convention, except paragraph 1.8., taken from OECD "Glossary of statistical terms".

- 1.12 "*Manufacturer*" means the person or body who is responsible to the Approval Authority for all aspects covered by the UN Regulations requirements for approval process and for ensuring the conformity of production. It is not essential that the person or body is directly involved in all stages of the construction of the vehicle or component which is the subject of the approval process.
- 1.13 "*Manufacturer's representative*" means any natural or legal person established in the Community who is duly appointed by the manufacturer to represent him to the approval authority and to act on his behalf in matters covered by the UN Regulations requirements for approval ,and where reference is made to the term 'manufacturer', it is to be understood as indicating either the manufacturer or his representative;
- 1.14 "*Component*" means a device intended to be part of a vehicle, which may be approved independently of a vehicle where the UN regulations makes express provisions for so doing.
- 1.15 "*Separate technical unit*" means a device intended to be part of a vehicle, which may be approved separately, but only in relation to one or more specified types of vehicle where the UN regulations makes express provisions for so doing.
- 1.16 "*Original parts or equipment*" means parts or equipment which are manufactured according to the specifications and production standards provided by the vehicle manufacturer for the production of parts or equipment for the assembly of the vehicle in question. This includes parts or equipment which are manufactured on the same production line as these parts or equipment. It is presumed unless the contrary is proven, that parts constitute original parts if the part manufacturer certifies that the parts match the quality of the components used for the assembly of the vehicle in question and have been manufactured according to the Un regulations requirements and specifications and production standards of the vehicle manufacturer;

2. **Classification of power-driven vehicles and trailers³**

- 2.1. Category L – **Motor vehicles with two and three and four wheels)**
- 2.1.1. "*Category L₁*": A two-wheeled vehicle with an engine cylinder capacity in the case of a thermic engine not exceeding 50 cm³ and whatever the means of propulsion a maximum design speed not exceeding 50 km/h.
- 2.1.2. "*Category L₂*":A three-wheeled vehicle of any wheel arrangement with an engine cylinder capacity in the case of a thermic engine not exceeding 50 cm³ and whatever the means of propulsion a maximum design speed not exceeding 50 km/h.
- 2.1.3. "*Category L₃*": A two-wheeled vehicle with an engine cylinder capacity in the case of a thermic engine exceeding 50 cm³ or whatever the means of propulsion a maximum design speed exceeding 50 km/h.

³ The text reproduced in this paragraph is the up-to-date version of Annex 7 to the consolidated Resolution (TRANS/WP.29/78/Rev.1) established by the Working Party on the Construction of Vehicles. It is based on document TRANS/WP.29/78/Rev.2.

- Definition of thermic engine Should be added., means of propulsion should be more explained .

- 2.1.4. "*Category L₄*": A vehicle with three wheels asymmetrically arranged in relation to the longitudinal median plane with an engine cylinder capacity in the case of a thermic engine exceeding 50 cm³ or whatever the means of propulsion a maximum design speed exceeding 50 km/h (motor cycles with sidecars).
- 2.1.5. "*Category L₅*": A vehicle with three wheels symmetrically arranged in relation to the longitudinal median plane with an engine cylinder capacity in the case of a thermic engine exceeding 50 cm³ or whatever the means of propulsion a maximum design speed exceeding 50 km/h.
- 2.1.6. "*Category L₆*": A vehicle with four wheels whose unladen mass is not more than 350 kg, not including the mass of the batteries in case of electric vehicles, whose maximum design speed is not more than 45 km/h, and whose engine cylinder capacity does not exceed 50 cm³ for spark (positive) ignition engines, or whose maximum net power output does not exceed 4 kW in the case of other internal combustion engines, or whose maximum continuous rated power does not exceed 4 kW in the case of electric engines.
- 2.1.7. "*Category L₇*": A vehicle with four wheels, other than that classified for the category L₆, whose unladen mass is not more than 400 kg (550 kg for vehicles intended for carrying goods), not including the mass of batteries in the case of electric vehicles and whose maximum continuous rated power does not exceed 15 kW.
- 2.2. Category M - Power-driven vehicles having at least four wheels and used for the carriage of passengers
- 2.2.1. "*Category M₁*": Vehicles used for the carriage of passengers and comprising not more than eight seats in addition to the driver's seat.
- 2.2.2. "*Category M₂*": Vehicles used for the carriage of passengers, comprising more than eight seats in addition to the driver's seat, and having a maximum mass not exceeding 5 tonnes.
- 2.2.3. "*Category M₃*": Vehicles used for the carriage of passengers, comprising more than eight seats in addition to the driver's seat, and having a maximum mass exceeding 5 tonnes.
- 2.2.4. Vehicles of categories M₂ and M₃ belong to:
- 2.2.4.1. For vehicles having a capacity exceeding 22 passengers in addition to the driver, there are three classes of vehicles:
- 2.2.4.1.1. "*Class I*": Vehicles constructed with areas for standing passengers, to allow frequent passenger movement.
- 2.2.4.1.2. "*Class II*": Vehicles constructed principally for the carriage of seated passengers, and designed to allow the carriage of standing passengers in the gangway and/or in an area which does not exceed the space provided for two double seats.
- 2.2.4.1.3. "*Class III*": Vehicles constructed exclusively for the carriage of seated passengers.
- 2.2.4.1.4. A vehicle may be regarded as belonging in more than one class. In such a case it may be approved for each class to which it corresponds.
- 2.2.4.2. For vehicles having a capacity not exceeding 22 passengers in addition to the driver, there are two classes of vehicles:

- 2.2.4.2.1. "Class A": Vehicles designed to carry standing passengers; a vehicle of this class has seats and shall have provisions for standing passengers.
- 2.2.4.2.2. "Class B": Vehicles not designed to carry standing passengers; a vehicle of this class has no provision for standing passengers.
- 2.2.5. Remarks
 - 2.2.5.1. "Articulated bus or coach" is a vehicle which consists of two or more rigid sections which articulate relative to one another; the passengers compartments of each section intercommunicate so that passengers can move freely between them; the rigid sections are permanently connected so that they can only be separated by an operation involving facilities which are normally only found in workshop.
 - 2.2.5.2. Articulated buses or coaches comprising two or more non-separable but articulated units shall be considered as single vehicles.
 - 2.2.5.3. In the case of a towing vehicle designed to be coupled to a semi-trailer (tractor for semi-trailer), the mass to be considered for classifying the vehicle is the mass of the tractor vehicle in running trim, increased by the mass corresponding to the maximum static vertical load transferred to the tractor vehicle by the semi-trailer and, where applicable, by the maximum mass of the tractor vehicle's own load.
 - 2.2.5.4. "Mass of a vehicle in running order" means the mass of an unladen vehicle with bodywork, and with coupling device in the case of a towing vehicle, or the mass of the chassis with cab if the manufacturer does not fit the bodywork and/or coupling device, including coolant, oils, 90 per cent of fuel, 100 per cent of other liquids except used waters, tools, spare wheel, driver (75 kg) and, for buses and coaches, the mass of the crew member (75 kg) if there is a crew seat in the vehicle.
- 2.3. Category N - Power-driven vehicles having at least four wheels and used for the carriage of goods
 - 2.3.1. "Category N_1 ": Vehicles used for the carriage of goods and having a maximum mass not exceeding 3.5 tonnes.
 - 2.3.2. "Category N_2 ": Vehicles used for the carriage of goods and having a maximum mass exceeding 3.5 tonnes but not exceeding 12 tonnes.
 - 2.3.3. "Category N_3 ": Vehicles used for the carriage of goods and having a maximum mass exceeding 12 tonnes.
 - 2.3.4. Remarks
 - 2.3.4.1. In the case of a towing vehicle designed to be coupled to a semi-trailer (tractor for semi-trailer), the mass to be considered for classifying the vehicle is the mass of the tractor vehicle in running trim, increased by the mass corresponding to the maximum static vertical load transferred to the tractor vehicle by the semi-trailer and, where applicable, by the maximum mass of the tractor vehicles own load.
 - 2.3.4.2. The equipment and installations carried on certain special purpose vehicles (crane vehicles, workshop vehicles, publicity vehicles, etc.) are regarded as being equivalent to goods.
- 2.4. Category O - Trailers (including semi-trailers)
 - 2.4.1. "Category O_1 ": Trailers with a maximum mass not exceeding 0.75 tonnes.

- 2.4.2. "*Category O₂*": Trailers with a maximum mass exceeding 0.75 tonnes, but not exceeding 3.5 tonnes.
- 2.4.3. "*Category O₃*": Trailers with a maximum mass exceeding 3.5 tonnes, but not exceeding 10 tonnes.
- 2.4.4. "*Category O₄*": Trailers with a maximum mass exceeding 10 tonnes.
- 2.4.5. Furthermore, trailers of categories O₂, O₃ and O₄ are of one of the three following types:
- 2.4.5.1. "*Semi-trailer*": A towed vehicle, in which the axle(s) is (are) positioned behind the centre of gravity of the vehicle (when uniformly loaded), and which is equipped with a connecting device permitting horizontal and vertical forces to be transmitted to the towing vehicle. One or more of the axles may be driven by the towing vehicle.
- 2.4.5.2. "*Full trailer*": A towed vehicle having at least two axles, and equipped with a towing device which can move vertically (in relation to the trailer) and controls the direction of the front axle(s), but which transmits no significant static load to the towing vehicle. One or more of the axles may be driven by the towing vehicle.
- 2.4.5.3. "*Centre-axle trailer*": A towed vehicle, equipped with a towing device which cannot move vertically (in relation to the trailer) and in which the axle(s) is (are) positioned close to the centre of gravity of the vehicle (when uniformly loaded) such that only a small static vertical load, not exceeding 10 per cent of that corresponding to the maximum mass of the trailer or a load of 1,000 daN (whichever is the lesser) is transmitted to the towing vehicle. One or more of the axles may be driven by the towing vehicle.
- 2.4.6. Remark
- In the case of a semi-trailer or centre-axle trailer, the maximum mass to be considered for classifying the trailer corresponds to the static vertical load transmitted to the ground by the axle or axles of the semi-trailer or centre-axle trailer when coupled to the towing vehicle and carrying its maximum load.
- 2.5. "*Special purpose vehicle*": A vehicle of category M, N or O for conveying passengers or goods and for performing a special function for which special body arrangements and/or equipment are necessary.
- 2.5.1. "*Motor caravan*": A special purpose M₁ category vehicle constructed to include accommodation space which contains at least the following equipment:
- (a) Seats and table;
 - (b) Sleeping accommodation which may be converted from the seats;
 - (c) Cooking facilities; and
 - (d) Storage facilities.
- This equipment shall be rigidly fixed to the living compartment; however, the table may be designed to be easily removable.
- 2.5.2. "*Armoured vehicle*": Vehicle intended for the protection of conveyed passengers and/or goods and complying with armour plating anti-bullet requirements.

- 2.5.3. "Ambulance": Motor vehicle of category M intended for the transport of sick or injured people and having special equipment for such purpose.
- 2.5.4. "Hearse": Motor vehicle intended for the transport of deceased people and having special equipment for such purpose.
- 2.6. Agricultural vehicles (Categories T, R and S)
- 2.6.1. "Category T" - means any motorised, wheeled or tracked agricultural or forestry vehicle having at least two axles and a maximum design speed of not less than 6 km/h, the main function of which lies in its tractive power and which has been especially designed to pull, push, carry and actuate certain interchangeable equipment designed to perform agricultural or forestry work, or to tow agricultural or forestry trailers or equipment; it may be adapted to carry a load in the context of agricultural or forestry work and/or may be equipped with one or more passenger seats.
- 2.6.2. "Category R - Agricultural trailer": means any agricultural or forestry vehicle intended mainly to be towed by a tractor and intended mainly to carry loads or to process materials and where the ratio of the technically permissible maximum laden mass to the unladen mass of that vehicle is equal to or greater than 3.0.
- 2.6.3. "Category S - Interchangeable towed equipment": means any vehicle used in agriculture or forestry which is designed to be towed by a tractor, changes or adds to its functions, permanently incorporates an implement or is designed to process materials, which may include a load platform designed and constructed to receive any tools and appliances needed for those purposes and to store temporarily any materials produced or needed during work and where the ratio of the technically permissible maximum laden mass to the unladen mass of that vehicle is less than 3.0.
- 2.7. "Non-road mobile machinery": Any mobile machine, transportable industrial equipment or vehicle with or without body work, not intended for the use of passenger- or goods-transport on the road, in which an internal combustion engine is installed.
- 2.8. Category G – off-road vehicles
- 2.8.1. Definition.
- Off-road vehicles are considered to be the vehicles of categories M and N satisfying the requirements of this paragraph, checked under the conditions indicated in paragraphs 2.8.2. and 2.8.3.
- 2.8.1.1. Vehicles in category N₁ with a maximum mass not exceeding 2 tonnes and vehicles in category M₁ are considered to be off-road vehicles if they have:
- (a) At least one front axle and at least one rear axle designed to be driven simultaneously including vehicles where the drive to one axle can be disengaged;
 - (b) At least one differential locking mechanism or at least one mechanism having a similar effect; and
 - (c) If they can climb a 30 per cent gradient calculated for a solo vehicle;
 - (d) In addition, they shall satisfy a least five of the following six requirements:
 - (i) The approach angle shall be at least 25°;

- (ii) The departure angle shall be at least 20°;
- (iii) The ramp angle shall be at least 20°;
- (iv) The ground clearance under the front axle shall be at least 180 mm;
- (v) The ground clearance under the rear axle shall be at least 180 mm;
- (vi) The ground clearance between the axles shall be at least 200 mm.

2.8.1.2. Vehicles in category N₁ with a maximum mass exceeding 2 tonnes or in category N₂, M₂ or M₃ with a maximum mass not exceeding 12 tonnes are considered to be off-road vehicles either if all their wheels are designed to be driven simultaneously, including vehicles where the drive to one axle can be disengaged, or if the following three requirements are satisfied:

- (a) At least one front axle and at least one rear axle are designed to be driven simultaneously, including vehicles where the drive to one axle can be disengaged;
- (b) There is at least one differential locking mechanism or at least one mechanism having a similar effect;
- (c) They can climb a 25 per cent gradient calculated for a solo vehicle.

2.8.1.3. Vehicles in category M₃ with a maximum mass exceeding 12 tonnes or in category N₃ are considered to be off-road either if the wheels are designed to be driven simultaneously, including vehicles where the drive to one axle can be disengaged, or if the following requirements are satisfied:

- (a) At least half the wheels are driven;
- (b) There is at least one differential locking mechanism or at least one mechanism having a similar effect;
- (c) They can climb a 25 per cent gradient calculated for a solo vehicle;
- (d) At least four of the following six requirements are satisfied:
 - (i) The approach angle shall be at least 25°;
 - (ii) The departure angle shall be at least 25°;
 - (iii) The ramp angle shall be at least 25°;
 - (iv) The ground clearance under the front axle shall be at least 250 mm;
 - (v) The ground clearance between the axles shall be at least 300 mm;
 - (vi) The ground clearance under the rear axle shall be at least 250 mm.

2.8.2. Load and checking conditions

2.8.2.1. Vehicles in category N₁ with a maximum mass not exceeding two tonnes and vehicles in category M₁ shall be in running order, namely with coolant fluid, lubricants, fuel, tools, spare-wheel and a driver considered to weigh a standard 75 kilograms.

- 2.8.2.2. Power-driven vehicles other than those referred to in paragraph 2.8.2.1. shall be loaded to the technically permissible maximum mass stated by the manufacturer.
- 2.8.2.3. The ability to climb the required gradients (25 per cent and 30 per cent) is verified by simple calculation. In exceptional cases, however, the Technical Services may ask for a vehicle of the type concerned to be submitted to it for an actual test.
- 2.8.2.4. When measuring front and rear incidence angles and ramp angles, no account is taken of underrun protective devices.
- 2.8.3. Definitions and sketches of front and rear incidence angles, ramp angle and ground clearance.

2.8.3.1. *"Approach angle"* – see Standard ISO 612 term No. 6.10.

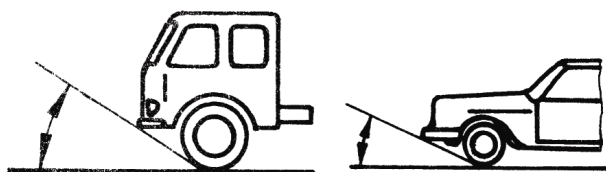

2.8.3.2. *"Departure angle"* – see Standard ISO 612 term No. 6.11.

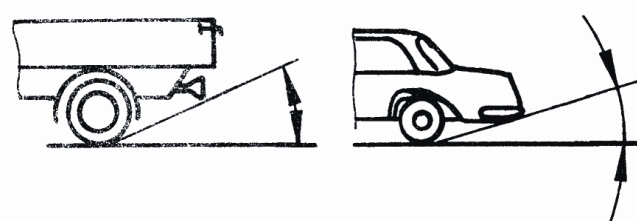

2.8.3.3. *"Ramp angle"* – see Standard ISO 612 term No. 6.9.

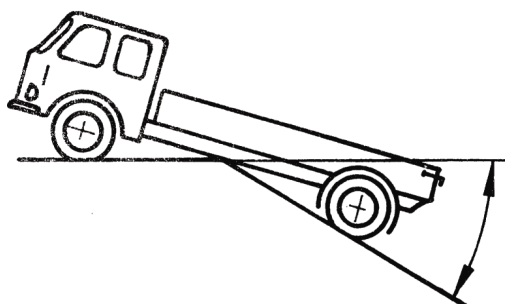

2.8.3.4. *"Ground clearance between the axles"*: means the shortest distance between the ground plane and the lowest fixed point of the vehicle.

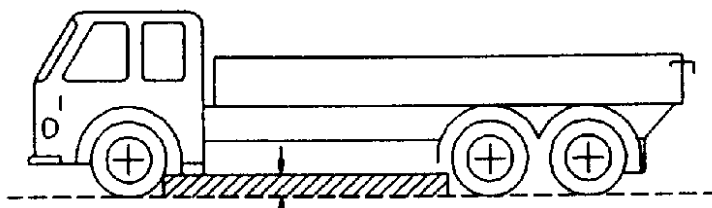

- 2.8.3.5. "Ground clearance beneath one axle": means the distance beneath the highest point of the arc of a circle passing through the centre of the tyre footprint of the wheels on one axle (the inner wheels in the case of twin tyres) and touching the lowest fixed point of the vehicle between the wheels.

No rigid part of the vehicle may project into the shaded area of the diagram.

Where appropriate, the ground clearance of several axles is indicated in accordance with their arrangement, for example 280/250/250.

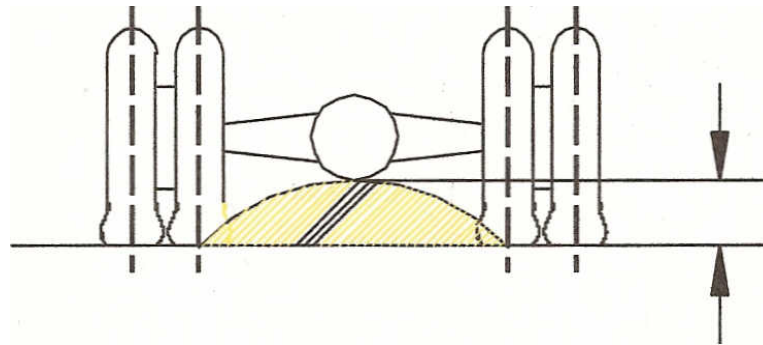

- 2.8.4. Combined designation
- Symbols M and N may be combined with symbol G. For example, a vehicle of category N₁ which is suited for off-road use may be designated as N₁G.
- 2.9. Definition of type of bodywork (only for complete/completed vehicles)
- The type of bodywork may be indicated by the following codification:
- 2.9.1. Passenger cars (M₁)
- 2.9.1.1. AA Saloon:
Standard ISO 3833 term No. 3.1.1.1., but including also vehicles with more than 4 side windows.
- 2.9.1.2. AB Hatchback
Saloon (AA) with a hatch at the rear end of the vehicle.
- 2.9.1.3. AC Station Wagon (Estate car)
Standard ISO 3833, term No. 3.1.1.4.
- 2.9.1.4. AD Coupé
Standard ISO 3833 term No. 3.1.1.5.
- 2.9.1.5. AE Convertible
Standard ISO 3833 term No. 3.1.1.6.
- 2.9.1.6. AF Multi-purpose vehicle
- Motor vehicle other than those mentioned in AA to AC intended for carrying passengers and their luggage or goods, in a single compartment. However, if such a vehicle meets both of the following conditions it is not considered to be a vehicle of category M₁:
- (a) The number of seating positions, excluding the driver, is not more than six. A "seating position" shall be regarded as existing if the vehicle is provided with "accessible" seat anchorages. "Accessible"

shall mean those anchorages to which can be used. In order to prevent anchorages being "accessible" the manufacturer shall physically obstruct their use, for example by welding over cover plates or by fitting similar permanent fixtures which cannot be removed by use of normally available tools; and

(b) $P - (M + N \times 68) > N \times 68$

Where:

P = technically permissible maximum laden mass in kg

M = mass in running order in kg

N = number of seating positions excluding the driver.

2.9.2. Special purpose vehicles (M₁)

2.9.2.1. SA Motor caravan: see paragraph 2.5.1.

2.9.2.2. SB Armoured vehicle: see paragraph 2.5.2.

2.9.2.3. SC Ambulance: see paragraph 2.5.3.

2.9.2.4. SD Hearse: see paragraph 2.5.4.

2.10 **Vehicle Identification Number (VIN) :**

The content and structure of a vehicle identification number (VIN) in order to establish, on a world-wide basis, a uniform identification numbering system applied for vehicles categories (M,N,O₁,O₂,L,T,.....)

VIN is a structured combination of characters assigned to a vehicle by the manufacturer for identification purposes, according to ISO 3779, ISO 4033, ISO 3780,

3. Scope of UN Regulations annexed to the 1958 Agreement

The scope of UN Regulations indicated below reflects the situation of the UN Regulations on 31 December 2015. The scopes are shown by categories of vehicles, but some of them may be limited to a specific subcategory/class or to a minimum/maximum weight within the category.

UN Regulations are continuously adapted to the technical progress and their scope may be modified.

UN Regulation	Title	L							M			N			O				T	R	S	NRMM	
		L ₁	L ₂	L ₃	L ₄	L ₅	L ₆	L ₇	M ₁	M ₂	M ₃	N ₁	N ₂	N ₃	O ₁	O ₂	O ₃	O ₄					
0	Uniform provisions concerning the International Whole Vehicle Type Approval (IWVTA)								x														

<i>UN Regulation</i>	<i>Title</i>	<i>L₁</i>	<i>L₂</i>	<i>L₃</i>	<i>L₄</i>	<i>L₅</i>	<i>L₆</i>	<i>L₇</i>	<i>M₁</i>	<i>M₂</i>	<i>M₃</i>	<i>N₁</i>	<i>N₂</i>	<i>N₃</i>	<i>O₁</i>	<i>O₂</i>	<i>O₃</i>	<i>O₄</i>	<i>T</i>	<i>R</i>	<i>S</i>	<i>NRMM</i>
1 and 2	Uniform provisions concerning the approval of motor vehicle headlamps emitting an asymmetrical passing-beam and/or a driving-beam and equipped with filament lamps of categories R ₂ and/or HS ₁ Uniform provisions concerning the approval of incandescent electric lamps for headlamps emitting an asymmetrical passing-beam or a driving-beam or both								x	x	x	x	x	x								
3	Uniform provisions concerning the approval of retro-reflecting devices for power-driven vehicles and their trailers	x	x	x	x	x	x	x	x	x	x	x	x	x	x	x	x	x	x			
4	Uniform provisions concerning the approval of devices for the illumination of rear registration plates of power-driven vehicles and their trailers								x	x	x	x	x	x	x	x	x	x	x			
5	Uniform provisions concerning the approval of power-driven vehicle's "sealed beam" headlamps (SB) emitting a European asymmetrical passing-beam or a driving-beam or both																		x			
6	Uniform provisions concerning the approval of direction indicators for power-driven vehicles and their trailers	x	x	x	x	x	x	x	x	x	x	x	x	x	x	x	x	x	x	x		
7	Uniform provisions concerning the approval of front and rear position lamps, stop-lamps and end-outline marker lamps for motor vehicles (except motor cycles) and their trailers	x	x	x	x	x	x	x	x	x	x	x	x	x	x	x	x	x	x			

UN Regulation	Title	L			L			M			N			O				T	R	S	NRMM				
		L ₁	L ₂	L ₃	L ₄	L ₅	L ₆	L ₇	M ₁	M ₂	M ₃	N ₁	N ₂	N ₃	O ₁	O ₂	O ₃					O ₄			
8	Uniform provisions concerning the approval of motor vehicle headlamps emitting an asymmetrical passing-beam or a driving-beam or both and equipped with halogen filament lamps (H ₁ , H ₂ , H ₃ , HB ₃ , HB ₄ , H ₇ , H ₈ , H ₉ , HIR ₁ , HIR ₂ and/or H ₁₁)							x	x	x	x	x	x												
9	Uniform provisions concerning the approval of category L ₂ , L ₄ and L ₅ vehicles with regard to noise		x		x	x																			
10	Uniform provisions concerning the approval of vehicles with regard to electromagnetic compatibility	x	x	x	x	x	x	x	x	x	x	x	x	x	x	x	x	x							
11	Uniform provisions concerning the approval of vehicles with regard to door latches and door retention components							x			x														
12	Uniform provisions concerning the approval of vehicles with regard to the protection of the driver against the steering mechanism in the event of impact							x			x														
13	Uniform provisions concerning the approval of vehicles of categories M, N and O with regard to braking								x	x	x	x	x	x	x	x	x	x							
13-H	Uniform provisions concerning the approval of passenger cars with regard to braking							x			x														
14	Uniform provisions concerning the approval of vehicles with regard to safety-belt anchorages, ISOFIX anchorages systems, ISOFIX top tether anchorages and i-Size seating positions							x	x	x	x	x	x												

UN Regulation	Title																						
		L ₁	L ₂	L ₃	L ₄	L ₅	L ₆	L ₇	M ₁	M ₂	M ₃	N ₁	N ₂	N ₃	O ₁	O ₂	O ₃	O ₄	T	R	S	NRMM	
15	This UN Regulation is obsolete																						
16	Uniform provisions concerning the approval of: I. Safety-belts, restraint systems, child restraint systems and ISOFIX child restraint systems for occupants of power-driven vehicles II. Vehicles equipped with safety-belts, safety-belt reminder, restraint systems, child restraint systems, ISOFIX child restraint systems and i-Size child restraint systems	x		x	x	x	x	x	x	x	x	x	x	x	x	x	x	x	x				
17	Uniform provisions concerning the approval of vehicles with regard to the seats, their anchorages and any head restraints								x	x	x	x	x	x									
18	Uniform provisions concerning the approval of motor vehicles with regard to their protection against unauthorized use								x	x		x	x										
19	Uniform provisions concerning the approval of power-driven vehicle front fog lamps		x	x	x		x	x	x	x	x	x	x						x				
20	Uniform provisions concerning the approval of motor vehicle headlamps emitting an asymmetrical passing-beam or a driving-beam or both and equipped with halogen filament lamps (H ₄ lamps)							x	x	x	x	x	x										
21	Uniform provisions concerning the approval of vehicles with regard to their interior fittings							x															

<i>UN Regulation</i>	<i>Title</i>	<i>L₁</i>	<i>L₂</i>	<i>L₃</i>	<i>L₄</i>	<i>L₅</i>	<i>L₆</i>	<i>L₇</i>	<i>M₁</i>	<i>M₂</i>	<i>M₃</i>	<i>N₁</i>	<i>N₂</i>	<i>N₃</i>	<i>O₁</i>	<i>O₂</i>	<i>O₃</i>	<i>O₄</i>	<i>T</i>	<i>R</i>	<i>S</i>	<i>NRMM</i>	
22	Uniform provisions concerning the approval of protective helmets and their visors for drivers and passengers of motor cycles and mopeds																						
23	Uniform provisions concerning the approval of reversing and manoeuvring lamps for power-driven vehicles and their trailers								x	x	x	x	x	x	x	x	x	x	x				
24	Uniform provisions concerning: I. The approval of compression ignition (C.I.) engines with regard to the emission of visible pollutants II. The approval of motor vehicles with regard to the installation of C.I. engines of an approved type III. The approval of motor vehicles equipped with C.I. engines with regard to the emission of visible pollutants by the engine IV. The measurement of power of C.I. engine	x	x	x	x	x	x	x	x	x	x	x	x	x									
25	Uniform provisions concerning the approval of head restraints (headrests), whether or not incorporated in vehicle seats		x		x	x	x	x	x	x	x	x	x	x									
26	Uniform provisions concerning the approval of vehicles with regard to their external projections								x														
27	Uniform provisions for the approval of advance-warning triangles																						
28	Uniform provisions concerning the approval of audible warning devices and of motor vehicles with regard to their audible signals			x	x	x			x	x	x	x	x	x									

<i>UN Regulation</i>	<i>Title</i>	<i>L₁</i>	<i>L₂</i>	<i>L₃</i>	<i>L₄</i>	<i>L₅</i>	<i>L₆</i>	<i>L₇</i>	<i>M₁</i>	<i>M₂</i>	<i>M₃</i>	<i>N₁</i>	<i>N₂</i>	<i>N₃</i>	<i>O₁</i>	<i>O₂</i>	<i>O₃</i>	<i>O₄</i>	<i>T</i>	<i>R</i>	<i>S</i>	<i>NRMM</i>
29	Uniform provisions concerning the approval of vehicles with regard to the protection of the occupants of the cab of a commercial vehicle											x	x	x								
30	Uniform provisions concerning the approval of pneumatic tyres for motor vehicles and their trailers								x			x			x	x						
31	Uniform provisions concerning the approval of power-driven vehicle's halogen sealed-beam headlamps (HSB) emitting an European asymmetrical passing beam or a driving beam or both								x	x	x	x	x	x						x		
32	Uniform provisions concerning the approval of vehicles with regard to the behaviour of the structure of the impacted vehicle in a rear-end collision								x													
33	Uniform provisions concerning the approval of vehicles with regard to the behaviour of the structure of the impacted vehicle in a head-on collision								x													
34	Uniform provisions concerning the approval of vehicles with regard to the prevention of fire risks								x	x	x	x	x	x	x	x	x	x				
35	Uniform provisions concerning the approval of vehicles with regard to the arrangement of foot controls								x													
36	Uniform provisions concerning the approval of large passenger vehicles with regard to their general construction									x	x											

UN Regulation	Title	L ₁	L ₂	L ₃	L ₄	L ₅	L ₆	L ₇	M ₁	M ₂	M ₃	N ₁	N ₂	N ₃	O ₁	O ₂	O ₃	O ₄	T	R	S	NRMM	
37	Uniform provisions concerning the approval of filament lamps for use in approved lamp units of power-driven vehicles and of their trailers	x	x	x	x	x	x	x	x	x	x	x	x	x	x	x	x	x	x				
38	Uniform provisions concerning the approval of rear fog lamps for power-driven vehicles and their trailers			x	x	x		x	x	x	x	x	x	x	x	x	x	x	x				
39	Uniform provisions concerning the approval of vehicles with regard to the speedometer equipment including its installation	x	x	x	x	x	x	x	x	x	x	x	x	x									
40	Uniform provisions concerning the approval of motor cycles equipped with a positive-ignition engine with regard to the emission of gaseous pollutants by the engine			x	x	x																	
41	Uniform provisions concerning the approval of motor cycles with regard to noise			x																			
42	Uniform provisions concerning the approval of vehicles with regard to their front and rear protective devices (bumpers, etc.)								x														
43	Uniform provisions concerning the approval of safety glazing materials and their installation on vehicles	x	x	x	x	x	x	x	x	x	x	x	x	x	x	x	x	x	x				
44	Uniform provisions concerning the approval of restraining devices for child occupants of power-driven vehicles ("Child Restraint System")																						
45	Uniform provisions concerning the approval of headlamp cleaners, and of power-driven vehicles with regard to headlamp cleaners	x	x	x	x	x	x	x	x	x	x	x	x	x						x			

<i>UN Regulation</i>	<i>Title</i>	<i>L₁</i>	<i>L₂</i>	<i>L₃</i>	<i>L₄</i>	<i>L₅</i>	<i>L₆</i>	<i>L₇</i>	<i>M₁</i>	<i>M₂</i>	<i>M₃</i>	<i>N₁</i>	<i>N₂</i>	<i>N₃</i>	<i>O₁</i>	<i>O₂</i>	<i>O₃</i>	<i>O₄</i>	<i>T</i>	<i>R</i>	<i>S</i>	<i>NRMM</i>
46	Uniform provisions concerning the approval of devices for indirect vision, and of motor vehicles with regard to the installation of these devices	x	x	x	x	x	x	x	x	x	x	x	x	x								
47	Uniform provisions concerning the approval of mopeds equipped with a positive-ignition engine with regard to the emission of gaseous pollutants by the engine	x	x																			
48	Uniform provisions concerning the approval of vehicles with regard to the installation of lighting and light-signalling devices								x	x	x	x	x	x	x	x	x	x				
49	Uniform provisions concerning the measures to be taken against the emission of gaseous and particulate pollutants from compression-ignition engines and positive ignition engines for use in vehicles								x	x	x	x	x	x								
50	Uniform provisions concerning the approval of front position lamps, rear position lamps, stop lamps, direction indicators and rear-registration-plate illuminating devices for vehicles of category L	x	x	x	x	x	x	x														
51	Uniform provisions concerning the approval of motor vehicles having at least four wheels with regard to their sound emissions								x	x	x	x	x	x								
52	Uniform provisions concerning the approval of M ₂ and M ₃ small capacity vehicles with regard to their general construction								x	x												

UN Regulation	Title	L							M			N			O				T	R	S	NRMM		
		L ₁	L ₂	L ₃	L ₄	L ₅	L ₆	L ₇	M ₁	M ₂	M ₃	N ₁	N ₂	N ₃	O ₁	O ₂	O ₃	O ₄						
53	Uniform provisions concerning the approval of category L ₃ vehicles with regard to the installation of lighting and light-signalling devices			x																				
54	Uniform provisions concerning the approval of pneumatic tyres for commercial vehicles and their trailers								x	x	x	x	x			x	x							
55	Uniform provisions concerning the approval of mechanical coupling components of combinations of vehicles								x	x	x	x	x	x	x	x	x	x						
56	Uniform provisions concerning the approval of headlamps for mopeds and vehicles treated as such	x	x																					
57	Uniform provisions concerning the approval of headlamps for motor cycles and vehicles treated as such			x	x	x	x	x																
58	Uniform provisions concerning the approval of: I. Rear underrun protective devices (RUPDs) II. Vehicles with regard to the installation of a RUPD of an approved type III. Vehicles with regard to their rear underrun protection (RUP)											x	x			x	x							
59	Uniform provisions concerning the approval of replacement silencing systems								x			x												

<i>UN Regulation</i>	<i>Title</i>	<i>L₁</i>	<i>L₂</i>	<i>L₃</i>	<i>L₄</i>	<i>L₅</i>	<i>L₆</i>	<i>L₇</i>	<i>M₁</i>	<i>M₂</i>	<i>M₃</i>	<i>N₁</i>	<i>N₂</i>	<i>N₃</i>	<i>O₁</i>	<i>O₂</i>	<i>O₃</i>	<i>O₄</i>	<i>T</i>	<i>R</i>	<i>S</i>	<i>NRMM</i>
60	Uniform provisions concerning the approval of two-wheeled motor cycles and mopeds with regard to driver-operated controls including the identification of controls, tell-tales and indicators	x		x																		
61	Uniform provisions concerning the approval of commercial vehicles with regard to their external projections forward of the cab's rear panel											x	x	x								
62	Uniform provisions concerning the approval of power-driven vehicles with handlebars with regard to their protection against unauthorized use	x	x	x	x	x	x	x														
63	Uniform provisions concerning the approval of two-wheeled mopeds with regard to noise	x																				
64	Uniform provisions concerning the approval of vehicles with regard to their equipment which may include: a temporary use spare unit, run flat tyres and/or a run flat-system, and/or a tyre pressure monitoring system								x			x										
65	Uniform provisions concerning the approval of special warning lamps for power-driven vehicles and their trailers	x	x	x	x	x	x	x	x	x	x	x	x	x	x	x	x	x	x			x
66	Uniform provisions concerning the approval of large passenger vehicles with regard to the strength of their superstructure									x	x											

UN Regulation	Title	L			M			N			O				T	R	S	NRMM
		L ₁	L ₂	L ₃	L ₄	L ₅	L ₆	L ₇	M ₁	M ₂	M ₃	N ₁	N ₂	N ₃				
67	Uniform provisions concerning the approval of: I. Specific equipment of vehicles of category M and N using liquefied petroleum gases in their propulsion system II. Vehicles of category M and N fitted with specific equipment for the use of liquefied petroleum gases in their propulsion system with regard to the installation of such equipment							x	x	x	x	x	x					
68	Uniform provisions concerning the approval of power-driven vehicles including pure electric vehicles with regard to the measurement of the maximum speed							x			x							
69	Uniform provisions concerning the approval of rear marking plates for slow-moving vehicles (by construction) and their trailers							x	x	x	x	x	x	x	x	x		x
70	Uniform provisions concerning the approval of rear marking plates for heavy and long vehicles							x	x			x	x	x	x			
71	Uniform provisions concerning the approval of agricultural tractors with regard to the driver's field of vision															x		
72	Uniform provisions concerning the approval of motor cycle headlamps emitting an asymmetrical passing-beam and a driving-beam and equipped with halogen filament lamps (HS ₁ lamps)		x	x	x													

UN Regulation	Title																						
		L ₁	L ₂	L ₃	L ₄	L ₅	L ₆	L ₇	M ₁	M ₂	M ₃	N ₁	N ₂	N ₃	O ₁	O ₂	O ₃	O ₄	T	R	S	NRMM	
73	Uniform provisions concerning the approval of: I. Vehicles with regard to their lateral protection devices (LPD) II. Lateral protection devices (LPD) III. Vehicles with regard to the installation of LPD of an approved type according to Part II of this Regulation											x	x			x	x						
74	Uniform provisions concerning the approval of category L ₁ vehicles with regard to the installation of lighting and light-signalling devices	x																					
75	Uniform provisions concerning the approval of pneumatic tyres for motor cycles and mopeds	x	x	x	x	x																	
76	Uniform provisions concerning the approval of headlamps for mopeds emitting a driving-beam and a passing-beam	x	x				x																
77	Uniform provisions concerning the approval of parking lamps for power-driven vehicles							x	x	x	x	x	x							x			
78	Uniform provisions concerning the approval of vehicles of category L ₁ , L ₂ , L ₃ , L ₄ and L ₅ with regard to braking	x	x	x	x	x																	
79	Uniform provisions concerning the approval of vehicles with regard to steering equipment							x	x	x	x	x	x	x	x	x	x	x					

UN Regulation	Title																						
		L ₁	L ₂	L ₃	L ₄	L ₅	L ₆	L ₇	M ₁	M ₂	M ₃	N ₁	N ₂	N ₃	O ₁	O ₂	O ₃	O ₄	T	R	S	NRMM	
80	Uniform provisions concerning the approval of seats of large passenger vehicles and of these vehicles with regard to the strength of the seats and their anchorages								x	x													
81	Uniform provisions concerning the approval of rear-view mirrors of two-wheeled power-driven vehicles with or without side car, with regard to the mounting of rear-view mirrors on handlebars	x	x	x	x	x	x	x															
82	Uniform provisions concerning the approval of moped headlamps equipped with filament halogen lamps (HS ₂)	x	x					x															
83	Uniform provisions concerning the approval of vehicles with regard to the emission of pollutants according to engine fuel requirements								x	x		x	x										
84	Uniform provisions concerning the approval of power-driven vehicles equipped with internal combustion engines with regard to the measurement of fuel consumption								x			x											
85	Uniform provisions concerning the approval of internal combustion engines or electric drive trains intended for the propulsion of motor vehicles of categories M and N with regard to the measurement of the net power and the maximum 30 minutes power of electric drive trains								x	x	x	x	x	x									
86	Uniform provisions concerning the approval of agricultural or forestry vehicles with regard to the installation of lighting and light-signalling devices																			x			

<i>UN Regulation</i>	<i>Title</i>	<i>L₁</i>	<i>L₂</i>	<i>L₃</i>	<i>L₄</i>	<i>L₅</i>	<i>L₆</i>	<i>L₇</i>	<i>M₁</i>	<i>M₂</i>	<i>M₃</i>	<i>N₁</i>	<i>N₂</i>	<i>N₃</i>	<i>O₁</i>	<i>O₂</i>	<i>O₃</i>	<i>O₄</i>	<i>T</i>	<i>R</i>	<i>S</i>	<i>NRMM</i>
87	Uniform provisions concerning the approval of daytime running lamps for power-driven vehicles	x	x	x	x	x	x	x	x	x	x	x	x	x					x			
88	Uniform provisions concerning the approval of retroreflective tyres for two-wheeled vehicles	x																				
89	Uniform provisions concerning the approval of: I. Vehicles with regard to limitation of their maximum speed or their adjustable speed limitation function II. Vehicles with regard to the installation of a speed limitation device (SLD) or adjustable speed limitation device (ASLD) of an approved type III. Speed limitation devices (SLD) and adjustable speed limitation device (ASLD)								x	x	x	x	x	x								
90	Uniform provisions concerning the approval of replacement brake lining assemblies, drum-brake linings and discs and drums for power-driven vehicles and their trailers	x	x	x	x	x	x	x	x	x	x	x	x	x	x	x	x	x				
91	Uniform provisions concerning the approval of side-marker lamps for motor vehicles and their trailers								x	x	x	x	x	x	x	x	x	x	x			
92	Uniform provisions concerning the approval of non-original replacement exhaust silencing systems (RESS) for motorcycles, mopeds and three-wheeled vehicles	x	x	x	x	x																

UN Regulation	Title																						
		L ₁	L ₂	L ₃	L ₄	L ₅	L ₆	L ₇	M ₁	M ₂	M ₃	N ₁	N ₂	N ₃	O ₁	O ₂	O ₃	O ₄	T	R	S	NRMM	
99	Uniform provisions concerning the approval of gas-discharge light sources for use in approved gas-discharge lamp units of power-driven vehicles								x	x	x	x	x	x									
100	Uniform provisions concerning the approval of vehicles with regard to specific requirements for the electric power train								x	x	x	x	x	x									
101	Uniform provisions concerning the approval of passenger cars powered by an internal combustion engine only, or powered by a hybrid electric power train with regard to the measurement of the emission of carbon dioxide and fuel consumption and/or the measurement of electric energy consumption and electric range and of categories M ₁ and N ₁ vehicles powered by an electric power train only with regard to the measurement of electric energy consumption and electric range								x			x											
102	Uniform provisions concerning the approval of: I. A close-coupling device (CCD) II. Vehicles with regard to the fitting of an approved type of CCD												x	x			x	x					
103	Uniform provisions concerning the approval of replacement pollution control devices for power-driven vehicles contents								x			x											
104	Uniform provisions concerning the approval of retro-reflective markings for vehicles of category M, N and O									x	x	x	x	x		x	x	x					

UN Regulation	Title	L ₁	L ₂	L ₃	L ₄	L ₅	L ₆	L ₇	M ₁	M ₂	M ₃	N ₁	N ₂	N ₃	O ₁	O ₂	O ₃	O ₄	T	R	S	NRMM
105	Uniform provisions concerning the approval of vehicles intended for the carriage of dangerous goods with regard to their specific construction features											x	x	x	x	x	x					
106	Uniform provisions concerning the approval of pneumatic tyres for agricultural vehicles and their trailers																		x			
107	Uniform provisions concerning the approval of category M ₂ and M ₃ vehicles with regard to their general construction								x	x												
108	Uniform provisions concerning the approval for the production of retreaded pneumatic tyres for motor vehicles and their trailers								x			x			x	x						
109	Uniform provisions concerning the approval for the production of retreaded pneumatic tyres for commercial vehicles and their trailers									x	x	x	x	x			x	x				
110	Uniform provisions concerning the approval of: I. Specific components of motor vehicles using compressed natural gas (CNG) and/or liquefied natural gas (LNG) in their propulsion system II. Vehicles with regard to the installation of specific components of an approved type for the use of compressed natural gas (CNG) and/or liquefied natural gas (LNG) in their propulsion system								x	x	x	x	x	x								

UN Regulation	Title																						
		L ₁	L ₂	L ₃	L ₄	L ₅	L ₆	L ₇	M ₁	M ₂	M ₃	N ₁	N ₂	N ₃	O ₁	O ₂	O ₃	O ₄	T	R	S	NRMM	
116	Uniform technical prescriptions concerning the protection of motor vehicles against unauthorized use								x			x											
117	Uniform provisions concerning the approval of tyres with regard to rolling sound emissions and/or adhesion on wet surfaces and/or rolling resistance								x	x	x	x	x	x	x	x	x	x					
118	Uniform technical prescriptions concerning the burning behaviour and/or the capability to repel fuel or lubricant of materials used in the construction of certain categories of motor vehicles										x												
119	Uniform provisions concerning the approval of cornering lamps for power-driven vehicles								x	x	x	x	x	x						x			
120	Uniform provisions concerning the approval of internal combustion engines to be installed in agricultural and forestry tractors and in non-road mobile machinery, with regard to the measurement of the net power, net torque and specific fuel consumption																			x			x
121	Uniform provisions concerning the approval of vehicles with regard to the location and identification of hand controls, tell-tales and indicators								x	x	x	x	x	x									
122	Uniform technical prescriptions concerning the approval of vehicles of categories M, N and O with regard to their heating systems								x	x	x	x	x	x	x	x	x	x					
123	Uniform provisions concerning the approval of Adaptive Front-lighting Systems (AFS) for motor vehicles								x	x	x	x	x	x									

<i>UN Regulation</i>	<i>Title</i>	<i>L₁</i>	<i>L₂</i>	<i>L₃</i>	<i>L₄</i>	<i>L₅</i>	<i>L₆</i>	<i>L₇</i>	<i>M₁</i>	<i>M₂</i>	<i>M₃</i>	<i>N₁</i>	<i>N₂</i>	<i>N₃</i>	<i>O₁</i>	<i>O₂</i>	<i>O₃</i>	<i>O₄</i>	<i>T</i>	<i>R</i>	<i>S</i>	<i>NRMM</i>
124	Uniform provisions concerning the approval of wheels for passenger cars and their trailers								x						x	x						
125	Uniform provisions concerning the approval of motor vehicles with regard to the forward field of vision of the motor vehicle driver								x													
126	Uniform provisions concerning the approval of partitioning systems to protect passengers against displaced luggage, supplied as non-original vehicle equipment								x													
127	Uniform provisions concerning the approval of motor vehicles with regard to their pedestrian safety performance											x										
128	Uniform provisions concerning the approval of light emitting diode (LED) light sources for use in approved lamp units on power-driven vehicles and their trailers	x	x	x	x	x	x	x	x	x	x	x	x	x	x	x	x	x	x	x		x
129	Uniform provisions concerning the approval of enhanced Child Restraint Systems used on board of motor vehicles (ECRS)																					
130	Uniform provisions concerning the approval of motor vehicles with regard to the Lane Departure Warning System (LDWS)									x	x		x	x								
131	Uniform provisions concerning the approval of motor vehicles with regard to the Advanced Emergency Braking Systems (AEBS)									x	x		x	x								

UN Regulation	Title	L							M			N			O				T	R	S	NRMM	
		L ₁	L ₂	L ₃	L ₄	L ₅	L ₆	L ₇	M ₁	M ₂	M ₃	N ₁	N ₂	N ₃	O ₁	O ₂	O ₃	O ₄					
132	Uniform provisions concerning the approval of Retrofit Emission Control Devices (REC) for heavy duty vehicles, agricultural and forestry tractors and non-road mobile machinery equipped with compression ignition engines								x	x		x	x	x					x				x
133	Uniform provisions concerning the approval of motor vehicles with regard to their reusability, recyclability and recoverability								x			x											
134	Uniform provisions concerning the approval of motor vehicles and their components with regard to the safety-related performance of Hydrogen-Fuelled Vehicles (HFCV)								x			x											
135	Uniform provisions concerning the approval of vehicles with regard to their Pole Side Impact performance (PSI)								x	x*		x	x*										
136	Uniform provisions concerning the approval of vehicles of category L with regard to specific requirements for the electric power train	x	x	x	x	x	x	x															
137	Uniform provisions concerning the approval of passenger cars in the event of a frontal collision with focus on the restraint system								x														
138	Uniform provisions concerning the approval of Quiet Road Transport Vehicles with regard to their reduced audibility (QRTV)								x			x											
139	Uniform provisions concerning the approval of passenger cars with regard to Brake Assist Systems (BAS)								x			x											

4. Active safety requirements

The table below contains the requirements or a group of requirements in the field of active safety, already adopted by the World Forum and included into UN Regulations. For any requirement or group of requirements, references are given to the relevant UN Regulations by their number in the 1958 Agreement and to the relevant Recommendations and Standard Annexes.

Subject		Relevant documents		
		UN Regulations annexed to the 1958 Agreement	Recommendations	Standard Annexes
A.	Braking, power-driven vehicles, and their trailers	13, 13-H, 90	See paragraphs 8.1. to 8.3.2.	
B.	Braking, motor cycles	78	See paragraphs 8.1. to 8.3.2.	
C.	Audible warning device, the audible signals of motor vehicles	28	See paragraph 8.4.	
D.	Lighting and light-signalling devices, power-driven vehicles	1, 2, 4, 5, 6, 7, 8, 19, 20, 23, 31, 37, 38, 45, 65, 77, 87, 91, 98, 99, 112, 119, 123	-	
E.	Lighting and light-signalling devices, motor cycles	50, 57, 72, 113	-	
F.	Lighting and light-signalling devices, mopeds	56, 76, 82, 128	-	
G.	Lighting and light-signalling, installation, motor vehicles	48, 128	-	
H.	Lighting and light-signalling, installation, motor cycles	53, 128	-	
I.	Lighting and light-signalling, installation, mopeds	74, 128	-	
J.	Lighting and light-signalling, installation, agricultural tractors	86, 128	-	
K.	Retro reflecting devices, markings	3, 69, 70, 88, 104	-	
L.	Pneumatic tyres and wheels for vehicles	30, 54, 64, 108, 109, 117, 124	-	
M.	Pneumatic tyres, commercial vehicles	54, 109, 117	-	
N.	Pneumatic tyres, motor cycles/mopeds	75	-	
O.	Pneumatic tyres, tractors	106	-	
P.	Controls, tell-tales, motor vehicles	35, 121	-	1
Q.	Controls, tell-tales, motor cycles, mopeds	60	-	
R.	Forward field of vision, motor vehicles	125	-	1

<i>Subject</i>		<i>Relevant documents</i>		
		<i>UN Regulations annexed to the 1958 Agreement</i>	<i>Recommendations</i>	<i>Standard Annexes</i>
S.	Indirect vision, motor vehicles	46	-	1
T.	Rear-view mirrors, motor cycles, mopeds	81	-	
U.	Drivers field of vision, tractors	71	-	
V.	Speed limitation (SLD)	89	-	
W.	Steering equipment	79	-	
X.	Lane Departure Warning System (LDWS)	130	-	
Y.	Advanced Emergency Braking Systems (AEBS), Brake Assist Systems and Electronic Stability Control	131, 139 and 140,144	-	

5. Passive safety requirements

The table below contains the requirements or a group of requirements in the field of passive safety, already adopted by the World Forum and included into UN Regulations. For any requirement or group of requirements, references are given to the relevant Regulations by their number in the 1958 Agreement and to the relevant Recommendations and Standard Annexes.

<i>Subject</i>		<i>Relevant documents</i>		
		<i>UN Regulations annexed to the 1958 Agreements</i>	<i>Recommendations</i>	<i>Standard Annexes</i>
A.	Frontal collision	33, 94,12, 134	-	1
B.	Lateral collision	95, 135	-	1
C.	Rear-end collision	32	-	1
D.	Front and rear protection device	42	-	
E.	Frontal collision for electric vehicles	12	-	1
F.	Front and rear underrun protection device	58, 93	-	
G.	Lateral protection	73	-	
H.	External projections	26, 61	See paragraphs 8.6. and 8.7.	1
I.	Interior fittings	21	-	1
J.	Seat strength	17,80	-	
K.	Restraint systems for adults	14, 16, 17, 25, 80, 114,145	-	1
L.	Child restraint systems	44, 129	-	
M.	Steering protection	12	-	1

<i>Subject</i>		<i>Relevant documents</i>		
		<i>UN Regulations annexed to the 1958 Agreements</i>	<i>Recommendations</i>	<i>Standard Annexes</i>
N.	Door latches and retention components	11	See paragraph 8.9.	
O.	Cabin of a commercial vehicle	29	See paragraphs 8.14. to 8.17.	1
P.	Fire risk	34, 118	-	
Q.	Passengers protection against displaced luggage	126,17	-	1
R.	Pedestrian safety	127	See paragraph 8.37.	

6. Requirements for the protection of the environment

The table below contains the requirements or a group of requirements for the protection of environment, already adopted by the World Forum and included into UN Regulations. For any requirement or group of requirements, references are given to the relevant Regulations by their number in the 1958 Agreement and to the relevant Recommendations and Standard Annexes.

<i>Subject</i>		<i>Relevant Documents</i>		
		<i>UN Regulations annexed to the 1958 Agreement</i>	<i>Recommendations</i>	<i>Standard Annexes</i>
A.	Pollutant emissions, motor vehicles	24, 49, 83, 103	-	
B.	Pollutant emissions, motor cycles, mopeds, P.I. engines	40, 47	-	
C.	Pollutant emissions, tractors	96	-	
D.	Measurements, maximum. speed, fuel consumption, net power	68, 84, 85, 101, 120	-	
E.	Noise emissions of motor vehicles and pneumatic tyres, internal noise of motor vehicles	51, 59, 117	See paragraph 8.8.	
F.	Noise emissions of motorcycles and mopeds	9, 41, 63, 92	See paragraph 8.8.	
G.	Retrofit Emission Control Devices (REC)	132, [143]		
H.	Recyclability of motor vehicles	133		

7. General safety requirements

The table below contains the requirements or a group of requirements in the field of general safety, already adopted by the World Forum and included into UN Regulations. For any requirement or group of requirements, references are given to the relevant UN Regulations by their number in the 1958 Agreement and to the relevant Recommendations and Standard Annexes.

Subject		Relevant Documents		
		UN Regulations annexed to the 1958 Agreement	Recommendations	Standard Annexes
A.	Protective helmets	22		
B.	Advance-warning triangles	27		
C.	Liquefied Petroleum Gas (LPG) vehicles, Compressed Natural Gas (CNG) vehicles and electric vehicles	67, 100, 110, 115, [137]		
D.	Coupling devices	55, 102	See paragraph 8.12.	
E.	Vehicles of specific use, ADR, tank vehicles	105, 111	-	
F.	Vehicle alarm and anti-theft systems	18, 62, 97, 116	See paragraph 8.24.	
G.	Buses and coaches	36, 52, 66, 107		
H.	Electromagnetic compatibility	10		
I.	Heating systems	122		
J.	Safety glazing	43		1
K.	Speedometer	39		
L.	Measures to prevent unauthorized modifications to mopeds and motor cycles in use	-	See paragraph 8.24.	
M.	Weight and axle load distribution	-	See paragraph 8.13.	
N.	Mudguards	-	See paragraph 8.27.	
O.	First aid kits	-	See paragraph 8.31.	

8. Recommendations

This chapter contains the text of the recommendations of the Consolidated Resolution, which are still valid.

8.1. Braking

8.1.1. Vehicles in service, used singly

8.1.1.1. A single motor vehicle may be maintained in service only if the respective performance of the service, emergency and parking braking devices are at least equal to 90 per cent of the performance prescribed for a new motor vehicle in UN Regulations Nos. 13 and 13-H.

- 8.1.1.2. The performance may be verified by methods and at speeds different from those prescribed in the relevant UN Regulations.
- 8.1.1.3. For the purpose of testing a motor vehicle in service, the vehicle is regarded as belonging to the category resulting from its characteristics and the weight indicated in its registration document.
- 8.1.2. Combination of new vehicles.
- 8.1.2.1. General Provisions
- 8.1.2.1.1. In addition to the requirements which, by virtue of UN Regulation No. 13, shall be met by each of their components, combinations of new vehicles shall satisfy the following conditions:
- 8.1.2.1.1.1. In a combination of which at least one component is used for the carriage of passengers, the performance of the service braking device and of the emergency braking device shall meet the requirements laid down in UN Regulation No. 13 for the drawing vehicle.
- 8.1.2.1.1.2. In other combinations.
- 8.1.2.1.1.2.1. The performance of the service braking device shall be such that the stopping distance is:
- $$S \leq 0.18 \cdot V + \frac{V^2}{115}$$
- V = Initial speed in km/h
S = Stopping distance in metres.
- (The second term corresponding to a mean braking deceleration of 4.4 m/sec²)
- 8.1.2.1.1.2.2. The performance of the secondary braking device shall be such that the stopping distance is:
- $$S \leq 0.18 \cdot V + \frac{2 \cdot V^2}{115}$$
- (The second term corresponding to a mean braking deceleration of 2.2 m/sec²)
- 8.1.2.1.2. The performances indicated in paragraphs 8.1.2.1.1.1. and 8.1.2.1.1.2. above shall be checked by a type-0 test with the engine disconnected, as described in UN Regulation No. 13, Annex 4, paragraph 1.4. The test shall be carried out at the speed prescribed for the motor vehicle, and the force applied on the controls shall not exceed the maximum prescribed for the braking of the motor vehicle alone (UN Regulation No. 13, Annex 4, paragraph 3.).
- 8.1.2.2. Continuous braking devices
- 8.1.2.2.1. In a combination of vehicles equipped with continuous braking devices, the vehicles of that combination shall meet the requirements laid down in UN Regulation No. 13 and in addition, the following conditions:
- 8.1.2.2.1.1. In an emergency manoeuvre, the time elapsing between the moment when the control begins to be actuated and the moment when the braking force on the least favourably placed axle reaches the level corresponding to the prescribed performance shall not exceed 0.6 sec (see UN Regulation No. 13, Annex 4, paragraph 4.1.1.);

- 8.1.2.2.1.2. The action of the service brakes shall be appropriately distributed and synchronized between the motor vehicle and the trailer.
- 8.1.3. Combinations of vehicles in service
- 8.1.3.1. A combination of vehicles, where both the motor vehicle and the trailer have been in use, may be maintained in service only:
- 8.1.3.1.1. If the respective performances of the service, emergency and parking braking devices are at least equal to 90 per cent of the performances prescribed in UN Regulation No. 13 (the parking brake performance for new motor vehicles and trailers is assumed to be 18 per cent), for each of the components when new;
- 8.1.3.1.2. If the respective performances of the service and emergency braking devices are at least equal to 90 per cent of the performances prescribed in UN Regulation No. 13, Annex 4, paragraph 2.3.2.
- 8.1.3.2. A combination of vehicles where either the drawing vehicle or the trailer has been in use shall satisfy the following conditions:
- 8.1.3.2.1. The requirements of UN Regulation No. 13 shall be met by that component of the combination, which is new.
- 8.1.3.2.2. For that component of the combination which has been in use, the respective performances of the service, emergency and parking braking devices shall be at least equal to 90 per cent of the performances prescribed for new vehicles in UN Regulation No. 13.
- 8.1.3.2.3. For the combination as a whole, the above provisions shall be met (see paragraph 8.1.3.1.2.).
- 8.1.3.3. The performance required under paragraphs 8.1.3.1., 8.1.3.2.2. and 8.1.3.2.3. may be verified by methods and at speeds different from those prescribed for new vehicles and combinations of new vehicles.
- 8.1.3.4. For the purpose of testing a vehicle in operation, the vehicle is regarded as belonging to the category resulting from its characteristics and the weight indicated in its registration document.
- 8.2. Resistance of brake pipes to corrosion
- The resistance of brake pipes to corrosion shall be at least equivalent to that of steel pipes coated with a 12-micron layer of zinc. It is further recommended that encouragement be given to information campaigns for the benefit of vehicle users, maintenance workshops and motor vehicle inspection services on the dangers of brake pipe corrosion.
- 8.3. Brake fluids
- 8.3.1. Manufacturers should include in the maintenance handbooks for their vehicles, in addition to the usual indications of the fluids to be used in braking equipment, a specific statement as to whether or not fluids of the non-petroleum type can be used.
- 8.3.2. Users' associations should draw the attention of vehicle users to the dangers of using unsuitable fluids or of mixing different, possibly incompatible, fluids.

- 8.4. Audible signals of cycles
 - 8.4.1. The provision of a bell is compulsory on cycles with auxiliary engine (if this category of vehicle is provided for in national regulations). This bell may, however, be replaced by a warning device. This audible warning shall be in conformity with the provisions of UN Regulation No. 28, however, the sound-pressure level of the device fitted to the vehicle shall be equal to or greater than 76 dB(A).
 - 8.4.2. On motor vehicles as defined in the 1968 Convention on Road Traffic, the provision of an audible warning device is compulsory.
 - 8.4.3. The provision of additional audible warning devices is not compulsory on cycles with auxiliary engine or on motor vehicles.
 - 8.4.4. Electrically-operated audible warning devices shall not be subject to stricter conditions than those set out above, it being understood that the present recommendation does not apply either to any audible warning devices mounted on vehicles for use in built-up areas only, or to the use and characteristics of alternating-tone or special-tone audible warning devices.
- 8.5. Pollutant emissions
 - 8.5.1. It is recommended to apply the requirements of the UN Regulations listed in the table of paragraph 6., rows A, B and C."
 - 8.5.2. Recommended limit values for a minimum set of market fuel quality parameters which affect vehicle emission control technologies are included in Annex 4.
- 8.6. External projections
 - 8.6.1. Passenger cars
 - Provisions contained in UN Regulation No. 26 apply. For devices not covered by that Agreement, the following provisions apply.
 - 8.6.1.1. A non-essential additional part (ornament or other accessory) may be mounted on the vehicle only if either it is so attached that a person struck can slide easily along it without being held or injured, or it bends under slight pressure so as to present no danger. In no case shall it exhibit sharp edges, points, hooks or projections.
 - 8.6.1.2. Any device (light surround, bumper or the like) installed or replaced by the user of a vehicle shall meet requirements similar to those prescribed in the above-mentioned UN Regulation No. 26.
 - 8.6.1.3. Roof rack, advertising panels, route indicators, taxi signs and other taxi accessories shall be securely attached to the vehicle and shall exhibit no point, sharp edge or tapered projection. The radii of curvature of the external parts, including the fastenings, shall be not less than 2.5 mm.
 - 8.6.1.4. The parts of a coupling device which extend beyond the external contour of the vehicle shall meet requirements similar to those prescribed in UN Regulation No. 26.
 - 8.6.1.5. Flag-holders and other devices of the same kind shall be able to tilt under slight pressure.
 - 8.6.1.6. In windscreen visors the radius of the extremities and that of the fastenings shall not be less than 2.5 mm.

- 8.6.1.7. Air or rain deflectors at the windows or on the roof shall not exhibit any point or sharp or cutting edge liable to endanger such road-users outside the vehicle as may come into contact with the deflectors.
- 8.7. External projections of L vehicles
- 8.7.1. Purpose of the recommendation
- This Recommendation is intended to ensure that the external projections on the vehicle are designed in such a way as to ensure that injuries, especially those caused by laceration or penetration, from which a person might suffer as a result of contact with (parts of) the vehicle, are reduced as far as reasonably practicable.
- The persons envisaged are:
- 8.7.1.1. The user of the vehicle (rider and passenger(s)),
- 8.7.1.2. Other road users, not themselves in vehicles, principally pedestrians, cyclists and motor cyclists, who might come into contact with the vehicle in the event of a low speed impact.
- 8.7.2. Scope
- This Recommendation applies to category L vehicles⁴
- 8.7.3. Definitions
- 8.7.3.1. "*Outer vehicle parts*" means all parts which are likely to be contacted in case of a collision with people;
- 8.7.3.2. "*Brushing*" means any contact which, under certain conditions, could cause injury by laceration;
- 8.7.3.3. "*Striking*" means any contact which, under certain conditions, could cause injury by penetration;
- 8.7.3.4. Criteria for distinguishing between "brushing" and "striking".
- 8.7.3.4.1. While moving the test device (see Figure 5) along the vehicle in accordance with paragraph 8.7.5.2. below, the components of the vehicle touched by the device shall be considered as either:
- 8.7.3.4.1.1. Group 1: those parts of components of the vehicle which brush against the test device, or
- 8.7.3.4.1.2. Group 2: those parts or components of the vehicle which strike against the test device.
- 8.7.3.4.1.3. In order to unambiguously differentiate between Group 1 and Group 2 parts or components, the following method shall be applied (Figure 1)

⁴ In the case of vehicles of category L4, the provisions below are not applicable to the space in between the sidecar and the motor cycle and the immediate surroundings thereof.

Figure 1

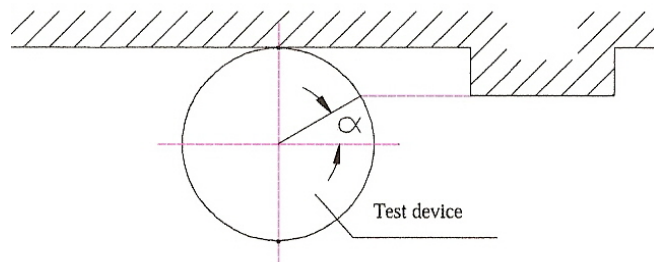

$\alpha > 45^\circ$: Group 1

$\alpha < 45^\circ$: Group 2

Thus for the fullest striking contact $\alpha = 0^\circ$.

8.7.3.5. "Radius of curvature" means the approximate extent of the round as distinct from a precise geometrical form.

8.7.4. General provisions

8.7.4.1. In any case, the outside of the vehicle shall not exhibit, directed outwards, any pointed or sharp parts or any projections of such shape, dimensions, direction or hardness as to be likely to increase the risk or seriousness of bodily injury to a person hit by the vehicle or brushing against it in the event of a collision or involved in a fall from the vehicle.

8.7.4.2. Vehicles shall be designed in such a manner that those parts with which the rider is likely to come into contact in the event of an accident shall cause as little injury as possible.

8.7.4.3. Vehicles shall be designed so that those parts with which other road users are likely to come into contact shall meet the requirements of paragraphs 8.7.6. and 8.7.7. below, as appropriate.

8.7.4.4. Any external projection covered by this Recommendation which is made of, or covered by, rubber or soft plastic with a rigidity below shore 60 A, shall be deemed to meet the requirements of paragraphs 8.7.6. and 8.7.7. below.

8.7.5. Test methodology

8.7.5.1. Test device and conditions

8.7.5.1.1. The test device shall be as shown in Figure 5.

8.7.5.1.2. The test vehicle shall be parked in the straight ahead position and shall be upright. The handlebars (if any) shall be free to rotate through their normal range of movement.

A dummy⁵ shall be mounted on the test vehicle in the normal riding position and in such a way that it does not restrict the movement of the handlebars (if any).

⁵ According to the Convention on Road Traffic of Vienna, 8 November 1968 and of the European Agreements supplementing that Convention, except paragraph 1.8., taken from OECD "Glossary of statistical terms."

8.7.5.2. Test procedure

The test device shall be moved from the front to the rear of the test vehicle, causing (if applicable and if they can be touched by the test device) the handlebars to turn to the full lock position. The test device shall remain in contact with the vehicle (see Figure 6). The test shall be carried out on both sides of the vehicle.

8.7.6. Criteria

8.7.6.1. The criteria specified in this paragraph shall not apply to those parts covered by the provisions of paragraph 8.7.7. below.

8.7.6.2. Subject to the provisions contained in paragraph 8.7.4.4. above, the following minimum criteria shall apply:

8.7.6.2.1. Requirements for Group 1

8.7.6.2.1.1. In the case of a plate (Figure 2)

Figure 2

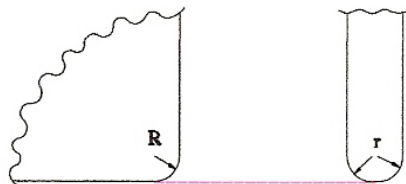

The corners shall have a radius of curvature (R) of at least 3 mm. The edges shall have a radius of curvature (r) of at least 0.5 mm.

8.7.6.2.1.2. In the case of a shaft (Figure 3)

Figure 3



The diameter of the shaft (d) shall be at least 10 mm.

The edges at the end of the shaft shall have a radius of curvature (r) of at least 2 mm.

8.7.6.2.2. Requirements for Group 2

8.7.6.2.2.1. In the case of a plate (Figure 2)

The corners shall have a radius of curvature (R) of at least 2 mm. The edges shall have a radius of curvature (r) of at least 2 mm.

8.7.6.2.2.2. In the case of a shaft (Figure 4)

Figure 4

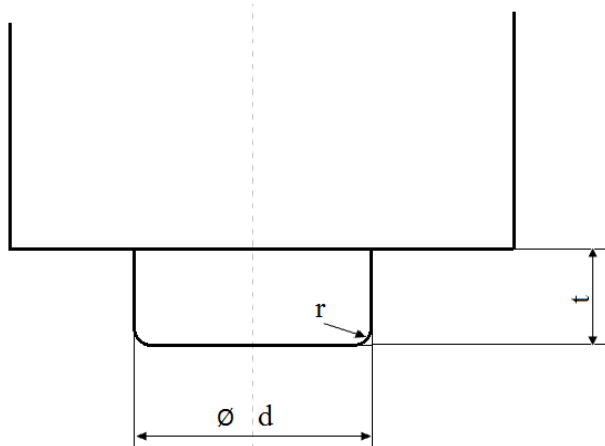

The length (t) shall be less than $d/2$, if the diameter of the shaft (d) is less than 20 mm.

The radius of curvature (r) of the edges at the end of the shaft shall be at least 2 mm, if the diameter of the shaft (d) is equal to or more than 20 mm.

8.7.7. Particular specifications

8.7.7.1. The upper edge of the wind shield or fairing shall have a radius of curvature of at least 2 mm or shall be covered with protective material.

8.7.7.2. The outer ends of hand-operated clutch and brake levers shall be rounded and shall have a minimum radius of curvature of 7 mm.

8.7.7.3. The leading edge of the front mudguard shall have a radius of curvature of at least 2 mm.

8.7.7.4. Filler caps located on the upper surface of the fuel reservoir and liable to be contacted by the driver in case of a frontal collision shall not project at their rear edge, more than 15 mm⁶ above the surrounding surface; their connections to the surrounding surface shall be levelled or rounded.

8.7.7.5. Ignition keys shall have protective caps.

This does not apply to collapsible keys and to keys that are flush with the surface.

8.7.7.6. Added ornaments shall not project more than 10 mm above the surrounding surface.

Up to a thickness of 5 mm they shall have chamfered edges and with a thickness of over 5 mm a radius of curvature of at least 2.5 mm.

⁶ Alternative measures (e.g. a deflector ramp behind the filler neck) shall be permitted if the 15 mm requirement cannot be fulfilled.

Figure 5

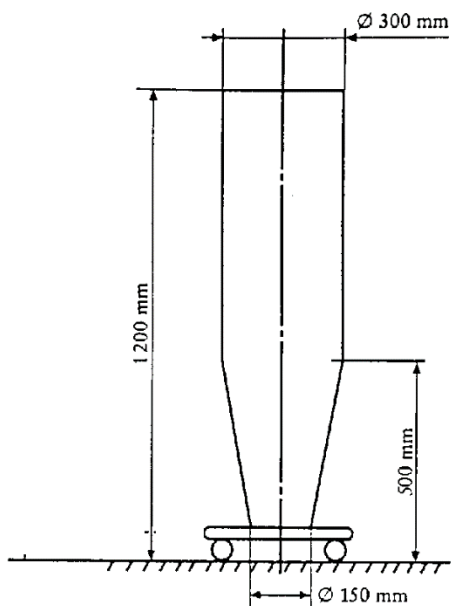
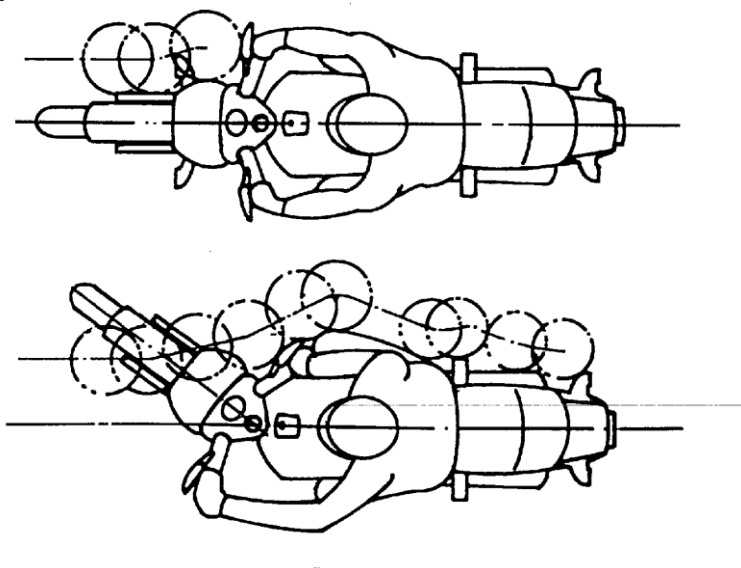

Figure 6



- 8.8. Noise emissions
- 8.8.1. Noise inside vehicles
- 8.8.1.1. Scope

This recommendation sets out provisions concerning the measurement of noise inside motor vehicles of categories M₂, M₃, N₁, N₂ and N₃, to which the driver and/or passengers occupying seats in the cab of the vehicle or in the passenger compartment are exposed.

- 8.8.1.2. Methods of measuring the sound level
- The noise produced by the vehicle type shall be measured in accordance with the two methods described in paragraph 8.38. for moving vehicles and for stationary vehicles.
- The test on the vehicle when stationary may usefully be taken as a reference value by Technical Services wishing to use this method to check vehicles in service.
- 8.8.2. Noise emitted by vehicles in use
- 8.8.2.1. To facilitate the prevention of sound pollution by vehicles in use through the introduction of simple checks, the use of the following sound-level measuring methods is recommended:
- 8.8.2.1.1. For vehicles of categories M and N, the method described in UN Regulation No. 51, Annex 3, paragraph 3.2. (Measurement of noise emitted by stationary vehicles, in proximity to the exhaust).
- 8.8.2.1.2. For vehicles of categories L₂, L₄, L₅, the method described in UN Regulation No. 9, Annex 3, paragraph 3.2. (Measurement of noise emitted by stationary vehicles, in proximity to the exhaust).
- 8.8.2.1.3. For vehicles of category L₃, the method described in UN Regulation No. 41, Annex 3, paragraph 2. (Measurement of noise emitted by stationary motor cycles, in proximity to the exhaust).
- 8.8.2.1.4. For vehicles of category L₁, the method described in UN Regulation No. 63, Annex 3, paragraph 3.2. (Measurement of noise emitted by stationary mopeds, in proximity to the exhaust).
- 8.8.2.2. In view of the tolerances of measuring instruments, the disturbances that may occur at the time of measurement and the scatter of measurements for vehicles of the same type, it will be necessary to allow for a margin of 5 dB(A) in comparison with the corresponding value recorded at the time of the type approval.
- 8.8.2.3. The last-mentioned value, and also the initial constant running speed of the engine, shall be entered in the registration documents of each new vehicle, or on the manufacturer's plate in the case of vehicles for which registration is not required.
- 8.8.2.4. Checks on vehicles brought into use prior to the introduction of this method shall be carried out in accordance with the procedures previously in force.
- 8.8.2.5. A visual inspection of the exhaust system and a check of its marking shall also be carried out where possible.
- 8.9. Door latches and door retention components
- Direction of operation of inside door handles
- Manufacturers should fit their door handles, when they rotate round a horizontal axis, in such a way that:
- (a) The handles move symmetrically to the median longitudinal axis of the vehicle;
- (b) In the closed (as distinct from the locked) position the handle is horizontal or nearly so and is pulled upwards to open the door.

- 8.10. Child restraints
It is recommended to apply the requirements of the UN Regulations listed in paragraph 5., the table, line L.
- 8.11. Compatibility between drawing vehicles and trailers
Not yet established.
- 8.12. Device to indicate a broken coupling
Drawing vehicles to which a trailer is coupled need not necessarily be equipped with a device for automatic signalling of the breakage of the trailers coupling.
- 8.13. Weight and axle load distribution
- 8.13.1. Passenger cars
Not yet established
- 8.13.2. Motor coaches and buses
The load distribution on the axles of motor coaches and buses shall be such that the front axle or axles carry at least 25 per cent of the total weight of the vehicle when stationary on a level road.
- 8.13.2.1. This condition shall be complied with both:
- 8.13.2.1.1. When the vehicle is empty and a weight equivalent to that of a driver is placed on the driver's seat; and
- 8.13.2.1.2. When the vehicle is fully laden with a load consisting of:
- (a) A weight equivalent to that of a passenger, which is placed on each seat provided;
 - (b) A weight equivalent to that of the permissible number of standing passengers, which is distributed uniformly over the area set aside for them; and
 - (c) A weight equivalent to the total permissible weight of luggage, which is distributed among the spaces reserved for luggage.
- 8.14. Protection of the occupants of goods-carrying power-driven vehicles against the shifting of loads
- 8.14.1. The equipment of vehicles (without prejudice to the provisions concerning the arrangement, and possibly concerning the securing, of loads on the vehicle) shall be in conformity with provisions calculated to reduce the risks run by the driver and the other occupants of goods-carrying vehicles in the event of a forward shift of the load on sudden braking, the following provisions being taken as a model:
- 8.14.1.1. The occupants of such a vehicle shall be protected by a screen or headboard capable of withstanding, without breaking, a uniformly-distributed static force of 800 daN per ton of the vehicle permissible load, exerted horizontally and parallel to the longitudinal median plane of the vehicle.
- This protective screen or headboard may be detachable.
- It shall meet the following requirements:

- 8.14.1.1.1. Its width (measured at right angles to the longitudinal median axis of the vehicle) shall be at least equal to the width of the space provided for the occupants and, where there is a separate cab, at least equal to the width of the cab;
- 8.14.1.1.2. In height it shall reach at least 800 mm above the level of the loading platform where there is a separate cab, or be of the same over-all height as the load compartment where there is no separate cab;
- 8.14.1.1.3. It shall be secured directly to the chassis or to the front of the loading platform. If it is secured to the loading platform or, where appropriate, to the body, the anchorage of that platform to the chassis shall be capable of withstanding the thrust transmitted. In cases where the cab is integral with the body, the protective screen or headboard may be secured to, or form part of, the body structure. In the case of an articulated vehicle, no protective screen need be provided on the vehicle drawing a semi-trailer; such a screen shall always be placed at the front of the semi-trailers loading platform.
- 8.14.2. In addition, if a power-driven vehicle or a semi-trailer is loaded with beams, pipes, girders, sheet metal or similar loads liable, in the event of failure of the securing devices, dangerously to penetrate the cab of the power-driven vehicle under the effect of sudden braking, the protective screen or headboard shall have a resistance at least equal to that of a steel plate not less than 3 mm thick.
- 8.14.3. Where a vehicle is equipped with a trestle or bolster behind the cab for the purpose of supporting long loads, such as steel girders or telegraph poles, the trestle or bolster shall be capable of withstanding the combined effect of two forces, each of 600 daN per ton of permissible load, acting forwards and downwards on the top of the trestle.
- 8.14.4. This recommendation shall not apply to passenger cars even when they are carrying goods, to tank-lorries and special-purpose vehicles for the carriage of containers, or to special-purpose vehicles used for the carriage of indivisible objects, where the latter vehicles and their operation are already subject to special UN Regulations.
- 8.15. Locking, for safe operation, of tilt cabs of motor vehicles normally used for carrying goods by road
 - 8.15.1. Cab in dropped position
 - 8.15.1.1. Tilt cabs shall be fitted with a main locking system and an auxiliary locking system.
 - 8.15.1.2. The main and auxiliary locking systems shall be independent of each other so that the failure of either does not entail the failure of the other.
 - 8.15.1.3. The main and auxiliary locking systems shall be able to withstand a force directed vertically upwards equivalent to one-and-one-half times the cab's weight.
 - 8.15.1.4. The main and auxiliary locking devices shall be so designed that they cannot either be worked inadvertently or open at the wrong time through the vehicle's acceleration or deceleration or vibrations due to the use of the vehicle.

- 8.15.1.5. If the driver himself cannot readily make certain, whether from outside the vehicle or from his seat, that the main locking device is properly engaged, a warning signal shall be fitted.
- 8.15.1.6. At least the auxiliary locking device shall be able to operate automatically when the cab is dropped to the normal driving position.
- 8.15.1.7. The auxiliary locking device shall be able to hold the cab in position should the main locking device fail.
- 8.15.1.8. A steady manual effort shall be required to release the auxiliary locking device so that the cab can tilt.
- 8.15.1.9. A plate or label indelibly inscribed with precise instructions on the operation of the locking devices shall be affixed in a clearly visible position on the vehicle.
- 8.15.2. Cab in raised position
The cab shall be capable of being held in the raised position either automatically or by means of a retaining device.
- 8.16. Mounting of the body or load platform of commercial vehicles
- 8.16.1. The axle-load limits shall not be exceeded when the vehicle is loaded to its permissible maximum weight, the load being uniformly distributed over the space provided for it.
- 8.16.2. The body or load platform shall be made and mounted taking into account the specifications, if any, of the chassis manufacturer.
- 8.16.3. The size and positioning of the mounting holes and/or welds shall be such that the strength of the chassis frame is not adversely affected. Holes in and welding on the flanges and the adjacent ends of the web of the side-members of the chassis frame shall be prohibited except where expressly permitted by the chassis manufacturer. In addition, no welding shall be allowed if this is expressly prohibited by the chassis manufacturer.
- 8.16.4. In mounting the body or load platform, all practicable steps shall be taken to keep the centre of gravity of the vehicle as low as possible.
In addition, this mounting shall not adversely affect the stability of the vehicle.
- 8.16.5. The body, including the necessary intermediate components, shall be attached directly to the chassis frame of the vehicle.
- 8.16.6. When U bolts are employed to secure the body or load platform to the chassis frame, spacers shall be used between the flanges of side-members to prevent buckling.
- 8.16.7. For mountings, use shall be made of round holes and suitable bolts with the least possible play, at least at the foremost and rearmost attachment points.
- 8.16.8. The mounting of the body or load platform shall be such as not to impair the soundness and functioning of the wiring and braking circuits.
- 8.16.9. Where the cab and bodywork are integral, account shall be taken of the flexibility of the cab mounting.
- 8.16.10. In the mounting of rigid bodies such as tanks, account shall be taken of any flexibility in the chassis frame.

- 8.16.11. In the case of tank-vehicles, where outrigger brackets are used to fasten the tank to the chassis of the vehicle, the vertical face of the brackets shall not be less in height than the depth of the chassis frame to which they are attached.
- 8.16.12. In the case of tipping vehicles, where there is no supplementary under frame to distribute the load, the pivot brackets for rearward-tipping bodies shall be located as near as possible to the rear spring brackets to minimize additional bending stresses on the chassis frame during tipping.
- 8.16.13. In the case of bodies tipping rearwards only, guide plates shall be provided to control the lateral movement of the body when lowered onto the chassis frame.
- 8.16.14. In the case of tipping bodies, steps shall be taken to prevent excessive noise caused by the bodywork of the vehicle when it is unladen.
- 8.17. Lashing and securing arrangements on road vehicles for sea transport on Ro/Ro ships
It is recommended to apply ISO standards (9367-1:1989, 9367-2:1989).
- 8.18. Caravans
Not yet established.
- 8.19. Driver's field of vision
It is recommended to apply the requirements of the UN Regulations listed in paragraph 4., the table, lines R and U.
- 8.20. Identification of controls and tell-tales
It is recommended to apply the requirements of the UN Regulations listed in paragraph 4., the table, lines P and Q.
- 8.21. Windscreen-wipers and washers
Not yet established.
- 8.22. Windscreen de-frosting and de-misting systems
Not yet established
- 8.23. Flammability of materials intended to be used inside road vehicles
It is recommended to apply the requirements of the UN Regulations listed in paragraph 5., the table, line P.
- 8.24. Measures to prevent unauthorized modifications to mopeds and motor cycles in use
- 8.24.1 Purpose of the Recommendation
This recommendation is intended to reduce to the extent possible unauthorized modification to certain classes of power-driven vehicles which are subject by legislation to restrictions on their engine capacity and/or their performance and/or their maximum speed.
- 8.24.2 Scope
- 8.24.2.1. This recommendation applies to:
- 8.24.2.1.1. Mopeds as defined in article 1 (m) of the 1968 Convention on Road Traffic and having two wheels only.

- 8.24.2.1.2. Mopeds within that definition but subject to other restrictions according to national legislation.
- 8.24.2.1.3. Derivatives of mopeds
- 8.24.2.1.4. Certain motor cycles (as defined in article 1 (n) of the 1968 Convention on Road Traffic), designed and constructed in accordance with national legislations, so as to have a restricted engine capacity and/or performance and/or maximum speed.
- 8.24.2.1.5. Certain motor cycles of other categories, used only for limited purposes, which are designed and constructed specially to meet such limitations, in agreement with the manufacturer.
- 8.24.3. General specifications
- 8.24.3.1. All vehicles offered for sale shall comply in all respects with the type approval (or the equivalent national) requirements.
- 8.24.3.2. The information on marking required in accordance with paragraph 8.24.4.1. below shall be annexed to the documents submitted with the application for type approval, or first registration as appropriate, of the vehicle.
- 8.24.4. Specific requirements
- 8.24.4.1. Marking of certain parts or components
- 8.24.4.1.1. The parts or components listed below shall be durably and indelibly marked with code number(s) and/or symbol(s) given by the vehicle manufacturer or alternatively by the manufacturer of such parts or components or by the type approval authority in order to identify those parts or components. Such marking shall be visible (so far as practicable) without the necessity of dismantling the part in question or other parts of the vehicle.
- 8.24.4.1.2. Letters figures or symbols shall preferably be at least 5 mm in height and shall be easily readable. In cases where a height of 5 mm is not practicable, this dimension may be reduced but shall not be less than 3 mm.
- 8.24.4.1.3. The parts and components referred to in paragraph 8.24.1.1. above are the following:
 - 8.24.4.1.3.1. Intake silencer (air filter or cleaner);
 - 8.24.4.1.3.2. Carburettor or equivalent instrument;
 - 8.24.4.1.3.3. Inlet manifold (if cast separately from the carburettor or cylinder);
 - 8.24.4.1.3.4. Cylinder;
 - 8.24.4.1.3.5. Cylinder head;
 - 8.24.4.1.3.6. Crankcase;
 - 8.24.4.1.3.7. Exhaust pipe(s);
 - 8.24.4.1.3.8. Silencer(s);
 - 8.24.4.1.3.9. Transmission driver member (front chain wheel (sprocket) or pulley);
 - 8.24.4.1.3.10. Transmission driven member (rear chain wheel (sprocket) or pulley);
 - 8.24.4.1.3.11. Speed-limitation devices.

- 8.24.4.2. Vehicle Manufacturers Identification Plate:
 - 8.24.4.2.1. A plate shall be affixed to each vehicle in a durable and permanent manner and in a visible place. On this plate the vehicle manufacturer shall state:
 - 8.24.4.2.1.1. His name or trade mark;
 - 8.24.4.2.1.2. The type of vehicle;
 - 8.24.4.2.1.3. The code number(s) or symbol(s) identifying the part or component marked in accordance with paragraph 8.24.4.1. above. A suggested model for simple correlation of the parts or components with their corresponding code number(s) or symbol(s) is shown in Figure 7 below.

Figure 7

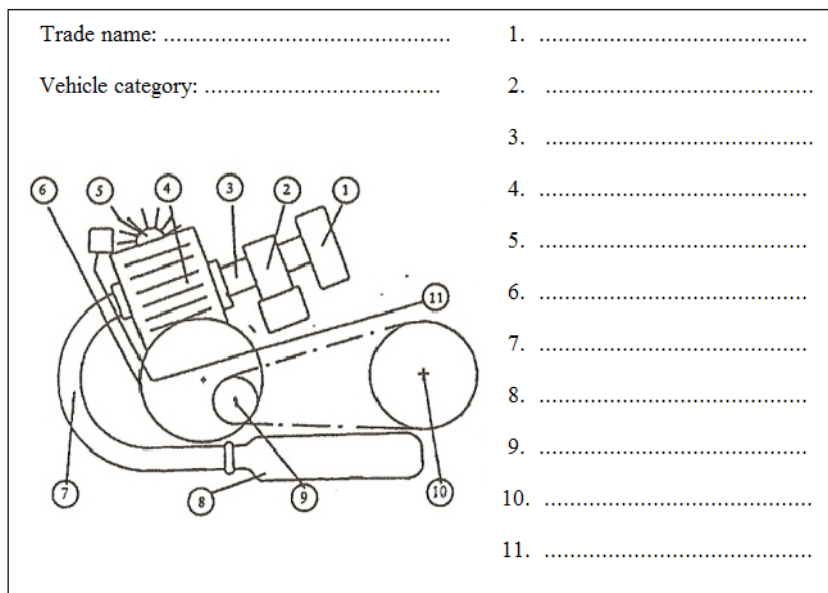

- 8.24.4.2.2. Letters, figures or symbols shall be at least 3 mm in height and shall be easily readable.
- 8.24.4.2.3. In the case of alternative parts or components being type approved (or granted an authorization) for the same vehicle, the code number(s) or symbol(s) of such alternative parts or components shall be shown on the plate.
- 8.24.5. Technical specifications
 - 8.24.5.1. Each vehicle shall be so designed and constructed as to comply with the specifications set out below:
 - 8.24.5.1.1. Cylinder head gasket: the maximum thickness of the cylinder head gasket shall not exceed 1.3 mm.
 - 8.24.5.1.2. Cylinder/crankcase joint: the maximum thickness of any gasket between the base of the cylinder and the crankcase shall not exceed 0.5 mm.
 - 8.24.5.1.3. The piston, when in the position at top dead centre, shall not cover the inlet port. This provision does not apply to those parts of the transfer port coincident with the inlet port in the case of vehicles, the engine of which is equipped with an induction system incorporating reed valve(s).

- 8.24.5.1.4. Rotation of the piston through 180° shall not increase the performance of the vehicle nor its design maximum speed.
- 8.24.5.1.5. In the event of the removal of the intake silencer, the design maximum speed of the vehicle shall not be increased by more than 5 km/h or 10 per cent of that speed, whichever is the lower.
- 8.24.5.1.6. There shall be no artificial restrictions in the gas passage which can be easily removed or modified.
- 8.24.5.1.6.1. This provision applies equally to reed or rotary valve systems, if such removal or modification causes an increase in the design maximum speed of the vehicle of more than 5 km/h or 10 per cent of that speed, whichever is the lower.
- 8.24.5.1.6.2. The valve guides of a four-stroke engine are not considered to be artificial restrictions.
- 8.24.5.1.7. The part(s) of the exhaust system inside the silencer(s) which determine(s) the effective length of the exhaust pipe shall be so affixed to the silencer(s) that it (they) cannot be removed.
- 8.24.5.1.8. In the event of a variation of the ignition timing and/or a change of the carburettor jet(s), the design maximum speed of the vehicle shall not be increased by more than 5 km/h or 10 per cent of that speed, whichever is the lower.
- 8.24.5.1.9. The design of cylinder and cylinder heads intended for different performance levels of the same basic engine shall be such that these parts cannot be fitted to an engine for which they are not appropriate; this can be obtained, for example, by different cylinder liner diameters, by different bolt patterns or different bolt diameters.
- 8.24.5.1.10. For 4-stroke engines a variation in camshaft timing shall not increase the maximum design speed above the values indicated in paragraphs 8.24.5.1.5 and 8.24.5.1.8.
- 8.24.5.1.11. For 4-stroke engines the design of the cylinder head shall be such that it cannot accommodate various camshafts intended for different performance levels of the same basic engine.
- 8.24.5.1.12. If the moped is equipped with electrical/electronic devices which limit the moped speed, the manufacturer shall provide data and evidence to the test authorities to demonstrate that modification or disconnection of the device, or its wiring system, will either not increase the maximum speed of the moped or will render the moped inoperative.

Electrical/electronic devices which cut or inhibit the spark ignition are forbidden if their disconnection results in an increase in either fuel consumption or unburnt hydrocarbons.

Electrical/electronic devices which vary the spark advance shall be designed so that the engine power, measured with the device functioning, does not differ by more than 10 per cent from the power measured with the device disconnected and with the advance set for maximum road speed.

The maximum road speed shall be achieved with the spark advance set within $\pm 5^\circ$ of the value specified for the development of maximum power.

- 8.25. Light-signalling
It is recommended to apply the requirements of the UN Regulations listed in paragraph 4., the table, lines D to J.
- 8.26. Tyres
It is recommended to apply the requirements of the UN Regulations listed in paragraph 4., the table, lines L to O.
- 8.27. Mudguards
The bodies of motor vehicles (other than special-purpose vehicles, agricultural or forest tractors and vehicles with a maximum rated speed not exceeding 20 km/h), and the bodies of all trailers coupled thereto, shall be equipped with effective mudguards, at least for their rear wheels.
- 8.28. Tachographs
The fitting of a tachograph⁷ should be compulsory on motor vehicles whose permissible maximum weight, including that of trailers permitted to be coupled to the vehicle, exceeds 7.5 tonnes, or which belong to category D as defined in Annexes 6 and 7 to the 1968 Convention on Road Traffic.
- 8.29. Information and communication systems in motor vehicles
- 8.29.1. Developments in the sphere of guidance, information and communications technology will result in crucial contributions towards solving transport problems in the field of road traffic. The following aspects, in particular, are of far-reaching significance:
- 8.29.1.1. The meshing and interconnecting of modes of transport in an integrated overall transport system;
- 8.29.1.2. A more efficient use of the transport infrastructure of all modes of transport;
- 8.29.1.3. Enhancing road safety and reducing environmental pollution;
- 8.29.1.4. Traffic avoidance and shifting traffic to more environment-friendly modes of transport.
- 8.29.2. The relevant systems, which either exist or are in development, are designed to assist the driver in performing his function of driving his vehicle, but they also make claims on his attention. To ensure that the use of such systems does not impair road safety, it is necessary to ensure that the licensing and design of these systems comply with certain requirements.
- 8.29.3. Guidelines for the design and installation of information and communications systems in motor vehicles will create a common basis on which the public sector and industry can tackle the tasks they face. They can also provide orientation for systems under development. Such guidelines can also supply a sound basis for the licensing and marketability of innovative products at the time being, not precluding, however, further development into UN Regulations.

⁷ Requirements on fitting of tachographs in accordance with the AETR (European Agreement concerning the Work of Crews of Vehicles engaged in international Road Transport) supersede this recommendation.

- 8.29.4. In some spheres, further studies will have to be conducted to deepen knowledge. These guidelines reflect a framework-model.
- 8.29.5. Governments wishing to apply provisions for the design and installation of information and communications systems in motor vehicles more precise through further research are recommended to consider the short and medium-term implementation of findings from the following fields:
- 8.29.5.1. Road safety (providing safe assistance to the driver in road traffic):
- 8.29.5.1.1. System safety (reliability of systems, suitability for international approval and monitoring, e.g. also electromagnetic compatibility);
- 8.29.5.1.2. Interaction safety (design of the driver-system interface).
- 8.29.5.2. Legal safety (questions of liability and issues relating to traffic legislation).
- 8.29.5.3. The ongoing standardization activities at CEN and ISO level should be also taken into account.
- 8.29.6. In keeping with the findings currently available, these guidelines deal primarily with the sphere of road safety, thereby also taking account of the priority that is attached to road safety. Governments wishing to apply requirements relating to in vehicle systems are recommended to base them on the following basic requirements:
- 8.29.6.1. All types of information and communications equipment in motor vehicles shall be designed such that the driver is not forced or encouraged to use both hands simultaneously while driving to operate it, not even for brief moments.
- 8.29.6.2. The use of all communications and information equipment that requires the driver to look at it shall be minimized while the vehicle is in motion. This means primarily that while the vehicle is in motion, functional information may be provided, i.e. information that assists the driver in his immediate task of driving his vehicle (including finding his way and planning his journey) and serves the purposes of freight and fleet management, vehicle checks, automatic registration of charges and other tasks related to driving. Information that is likely to greatly distract the driver visually (for instance TV, video, commercials) shall either be switched off completely while the vehicle is in motion or may be presented only in such a way that the driver cannot see it directly.
- 8.29.6.3. The information system shall not deactivate or interfere with existing control equipment and prescribed instruments, in particular those that are required for road safety and safety of operation and those that the driver requires to be able to drive his vehicle safely.
- 8.29.6.4. The proper use of information systems in motor vehicles, as well as the total or partial failure of such systems, shall not impair the safe operation of the vehicle. This means that the driver shall at all times be able to perform by himself his primary task of driving his vehicle.
- 8.29.6.5. The information system shall not pose a danger to the passengers or other road users. This statement also applies to the foreseeable incorrect operation of the system by inexperienced users.
- 8.29.6.6. In the case of speech-based communications systems that are designed to be used by the driver while the vehicle is in motion, provision shall be made for hands-free speaking and listening equipment.

- 8.29.7. Irrespective of a further research that has to be done it is agreed that in the development and employment of information and communications systems for road vehicles, it is recommended that account be taken of the following requirements:
- 8.29.7.1. The mere presence of a system, and the functions of a system, should not result in any impairment of the functions of other systems in the vehicle or of the vehicle itself.
- 8.29.7.2. Information systems should be easy to use.
- 8.29.7.3. It should be possible to switch off the output of information by the system, in order to leave it to the driver whether or not he wishes to use the system.
- 8.29.7.4. If the information system is designed for use by the front-seat passenger and the driver, it should be installed such that proper use by the passenger cannot have a negative effect on the driver.
- 8.29.7.5. Visual information and communication should not be distributed over several display media if this could result in the driver having to divide his attention in the visual sphere, which would be detrimental to safety.
- 8.29.7.6. The position of the information systems should be selected such that when the driver averts his eyes from the road ahead the movement of his eyes horizontally and vertically is as slight as possible, and that the systems are easy to read.
- 8.29.7.7. The information system should be designed such that it does not distract the driver excessively and could not potentially cause him to drive in a dangerous manner (for instance by overreacting).
- 8.29.7.8. In order to ensure that it is used, the information system should not require the driver to reply or respond within a specific period of time. The driver shall be able to determine the speed of interaction himself or to interrupt it. Nor shall the attention that he driver requires for the primary task of driving his vehicle be diverted for any length of time.
- 8.29.7.9. The information provided should, whenever practicable, assist the driver in a timely manner and in line with his requirements. Thus, for instance, routine information should be provided well in advance, to enable the driver to execute the necessary manoeuvre safely.
- 8.29.7.10. Input by keyboard should be minimized while the vehicle is in motion or should be possible when the vehicle is stationary. Lengthy and repeated series of actions should be avoided. Controls should be limited to those that are absolutely necessary and designed such that they can largely be operated without looking (haptic aids).
- 8.29.7.11. In order to minimize the amount of time during which the driver has to avert his eyes and to reduce the over-stimulation of his sense of vision, it is recommended that the acoustic information channel be used.
- 8.29.7.12. Instructions regarding the information system, its installation and operation should be correct, adequate, simple and written in the language of the country concerned. They should be designed such that future users can also learn how to use the system (learning by using).
- 8.29.7.13. The operating instructions should also highlight potential dangers and system constraints, and should point out that vehicle information systems may only be used in such a way that they do not constitute a safety hazard.

- 8.30. Supports for motor cycles
- 8.30.1. Purpose of the recommendation
- This Recommendation is intended to ensure, so far as is reasonably practicable, that the installation and use of the supports with which two-wheeled motor vehicles are equipped do not present hazards either to the users of the vehicle or to any other road user.
- 8.30.2. Scope
- This Recommendation applies to mopeds and motor cycles having two wheels only and not equipped with side-cars.
- 8.30.3. Definitions
- 8.30.3.1. "*Vehicle*" means a moped or a motor-cycle as defined in the Vienna Convention on Road Traffic, 1968, article 1 (m) and (n) respectively, to the exclusion of vehicles equipped with side-cars or having three wheels;
- 8.30.3.2. "*Support*" means a device securely affixed to the vehicle by means of which the vehicle can be maintained in the parked, upright (or near upright) position when it is at rest and not attended by the rider;
- 8.30.3.3. "*Side stand*" means a support which, when extended or pivoted into the open position, supports the vehicle on one side only, leaving both wheels in contact with the supporting surface;
- 8.30.3.4. "*Centre stand*" means a support which, when extended into open position, supports the vehicle by providing an area, or areas, of contact between the vehicle and the supporting surface, distributed on either side of the longitudinal median plane of the vehicle;
- 8.30.3.5. "*Tilt*" means the inclination, measured as a percentage (see Figure 8 below), of the supporting surface produced by raising or lowering one side of the supporting surface in relation to the horizontal in such a manner that the intersection of the supporting surface and the horizontal plane is parallel to the longitudinal median plane of the vehicle;
- 8.30.3.6. "*Slope*" means the inclination, measured as a percentage (see Figure 9 below), of the supporting surface produced by raising or lowering one side of the supporting surface in relation to the horizontal in such a manner that the intersection of the supporting surface and the horizontal plane is perpendicular to the longitudinal median plane of the vehicle;
- 8.30.3.7. "*Longitudinal median plane*" of the vehicle means the longitudinal plane of symmetry of the rear wheel of the vehicle;
- 8.30.3.8. "*Unladen kerb mass*" means the mass of the vehicle in running order, without occupant or load, but with fuel, coolant, lubricant, tool-kit and spare wheel (if normally provided by the manufacturer).
- 8.30.4. General requirements
- 8.30.4.1. Every vehicle shall be equipped with some form of support to ensure its stability at rest (for example, when it is parked) and not maintained in a static position by human or external means.
- 8.30.4.2. Such support shall be either:
- 8.30.4.2.1. A side stand; or

- 8.30.4.2.2. A centre stand.
- 8.30.4.3. This recommendation shall neither require a vehicle to be equipped with more than one, or more than one type of, support, nor prevent a vehicle from being so equipped.
- 8.30.4.4. Supports shall be so designed and constructed as to be:
 - 8.30.4.4.1. Free from all unnecessary sharp edges and projections which might cause injury to the rider, the passenger or third parties coming into contact with the support (Radius of curvature of not less than 2.5 mm is considered to satisfy this requirement);
 - 8.30.4.4.2. Easy to use and precise in their action;
 - 8.30.4.4.3. Unlikely to cause permanent deformation of the supporting surface when in the open or parking position.
- 8.30.4.5. In the case of a support which is hinged to the lower part or underside of the vehicle, the outer extremity (extremities) of the support shall, in order to place it in the closed or riding position, move towards the rear of the vehicle.
- 8.30.5. Special requirements
 - 8.30.5.1. Side stands
 - 8.30.5.1.1. Side stands shall possess the following characteristics:
 - 8.30.5.1.1.1. The ability to support the vehicle, in such a manner as to ensure the lateral stability of the vehicle, whether on a horizontal supporting surface or under conditions of tilt, so that the vehicle cannot be either too easily further inclined (and hence made to overbalance, using the side stand as a fulcrum) or too easily moved into or beyond the vertical position (and hence made to overbalance and fall onto the side opposite the side stand);
 - 8.30.5.1.1.2. The ability to support the vehicle in such a manner as to ensure positive positioning when the vehicle is under conditions of slope;
 - 8.30.5.1.1.3. The ability to fold back into the closed or riding position automatically;
 - 8.30.5.1.1.3.1. When the vehicle is returned to the normal (vertical) position for riding, or
 - 8.30.5.1.1.3.2. As a result of the vehicle being moved forward by a deliberate action of the rider, or
 - 8.30.5.1.1.3.3. Without disturbing the equilibrium of the vehicle, if the side stand comes into contact with the supporting surface while the vehicle is moving;
 - 8.30.5.1.1.4. Notwithstanding the provisions of paragraph 8.30.5.1.1.3. above, the side stand shall nevertheless be designed and constructed in such a manner that
 - 8.30.5.1.1.4.1. Once moved into the open or parking position,
 - 8.30.5.1.1.4.2. With the vehicle inclined in order to bring the outer extremity of the side stand into contact with the ground, or
 - 8.30.5.1.1.4.3. When the vehicle is left unattended in the parked position, the side stand will not automatically close if the angle of inclination is inadvertently changed (for example, because the vehicle is slightly moved by a third party or because of wind pressure created by a passing vehicle).
 - 8.30.5.1.2. Instead of conforming to the provisions of paragraphs 8.30.5.1.1.3. and 8.30.5.1.1.4. above, the vehicle may be equipped with a side stand which is connected to its ignition system in such a manner that the ignition system can only be activated when the side stand is in the closed or riding position.

- 8.30.5.2. Centre stands
- 8.30.5.2.1. Centre stands shall possess the following characteristics:
- 8.30.5.2.1.1. The ability to support the vehicle with one wheel, both wheels or neither wheel in contact with the supporting surface in such a manner as to ensure the stability of the vehicle:
- (a) On a horizontal supporting surface;
 - (b) Under conditions of tilt;
 - (c) Under conditions of slope.
- 8.30.5.2.1.2. The ability to fold back into the closed or riding position automatically:
- (a) When the vehicle is moved forward in such a manner as to disengage the centre stand from the supporting surface, or
 - (b) Without disturbing the equilibrium of the vehicle, if the centre stand comes into contact with the supporting surface while the vehicle is moving.
- 8.30.5.2.2. Instead of conforming to the provisions of paragraph 8.30.5.2.1.2. above, a vehicle to which only a centre stand is fitted may be equipped with a centre stand which is connected to its ignition system in such a manner that the ignition system can only be activated when the centre stand is in the closed or riding position.
- 8.30.5.3. All supports
- 8.30.5.3.1. Vehicles which are equipped in accordance with the provisions of paragraphs 8.30.5.1.2. or 8.30.5.2.2. above may in addition be equipped with a warning light, clearly discernible by the rider when seated in the riding position which, when the ignition is switched on, comes on and remains on until the support is in the closed or riding position.
- 8.30.5.3.2. Supports shall be equipped with a retaining system to secure them in the closed or riding position.
- The system may consist of either:
- (a) Two independent devices, such as two separate springs or a spring and a retaining device such as a clip, or
 - (b) A single device which shall be capable of operating without failure for at least 10,000 cycles of normal use if the vehicle is equipped with two supports, or 15,000 cycles of normal use if the vehicle is equipped with a single support.
- 8.30.6. Tests for stability
- In order to establish the ability to support the vehicle in a stable condition as specified in paragraph 8.30.5. of this Recommendation, the following tests shall be undertaken.
- 8.30.6.1. Condition of the vehicle
- 8.30.6.1.1. The vehicle shall be at its unladen kerb mass.
- 8.30.6.1.2. The tyres shall be inflated to the pressure recommended by the manufacturer for these conditions.

- 8.30.6.1.3. The transmission shall be in neutral or, in the case of automatic transmission, in the parking position if provided.
- 8.30.6.1.4. If the vehicle is equipped with a parking brake, it shall be applied.
- 8.30.6.1.5. The steering head shall be in the locked position. If the steering can be locked when turned either to the left or to the right, the tests shall be carried out with the steering head in both positions.
- 8.30.6.2. Test area
Any flat, horizontal area with a hard, dry surface, free from grit, may be used for the tests defined in paragraph 8.30.7.1. below.
- 8.30.6.3. Test equipment
 - 8.30.6.3.1. A parking platform shall be used for the tests set out in paragraph 8.30.7.2. below.
 - 8.30.6.3.2. The parking platform shall be a rigid, flat, rectangular surface capable of supporting the vehicle without significant flexing.
 - 8.30.6.3.3. The surface of the parking platform shall provide sufficient friction to prevent the vehicle from sliding in relation to the supporting surface during the tests for tilt or slope.
 - 8.30.6.3.4. The parking platform shall be so constructed as to be capable of assuming at least the inclinations to the horizontal prescribed in paragraph 8.30.7.2.2.
- 8.30.7. Test procedure
 - 8.30.7.1. Stability on a horizontal supporting surface (Test for paragraph 8.30.5.1.1.4. above).
 - 8.30.7.1.1. With the vehicle in the test area, the side stand shall be placed in the open or parking position and the vehicle allowed to rest upon the side stand.
 - 8.30.7.1.2. The vehicle shall be moved so that the angle formed by the longitudinal median plane and the supporting surface is increased by moving the vehicle towards the upright position by 3°.
 - 8.30.7.1.3. The side shall not, as a result of this movement, automatically return to the closed or riding position.
 - 8.30.7.2. Stability on an inclined surface (Tests for paragraphs 8.30.5.1.1.1., 8.30.5.1.1.2., 8.30.5.2.1.1.2. and 8.30.5.2.1.1.3. above).
 - 8.30.7.2.1. The vehicle shall be placed on the parking platform with the side stand, and separately, with the centre stand placed in the open or parking position, and the vehicle allowed to rest upon the support.
 - 8.30.7.2.2. The parking platform shall be inclined as shown in Figures 8, 9(a) and 9(b) according to the following minimum tilt and slope inclinations:

	<i>Side stand</i>		<i>Centre stand</i>	
	<i>Mopeds (%)</i>	<i>Motor cycles (%)</i>	<i>Mopeds (%)</i>	<i>Motor cycles (%)</i>
Tilt	5	6	6	8
Slope downward	5	6	6	8
Slope upward	6	8	12	14

- 8.30.7.2.3. Where a vehicle is placed on an inclined parking platform by use of the centre stand and one wheel only and can be maintained in that position with the centre stand and either the front or the rear wheel in contact with the supporting surface, provided the other conditions of this paragraph are complied with, the foregoing tests shall be carried out with the vehicle placed upon the centre stand and the rear wheel only.
- 8.30.7.2.4. With the parking platform inclined to each of the prescribed inclinations and the foregoing conditions duly observed, the vehicle shall remain in a stable condition.
- 8.30.7.2.5. Instead of this procedure, the parking platform may be pre-set to the requisite inclinations before the vehicle is placed in position.

Figure 8
Tilt

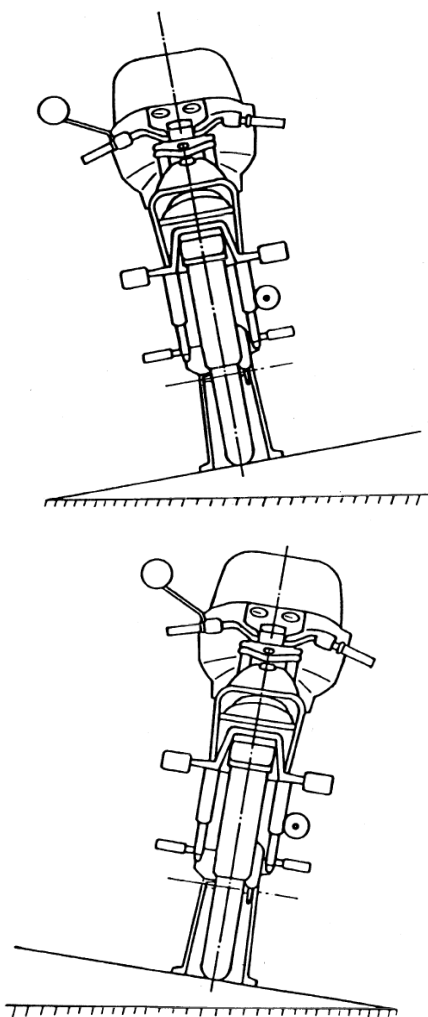

Figure 9 (a)
Slope – Upward inclination

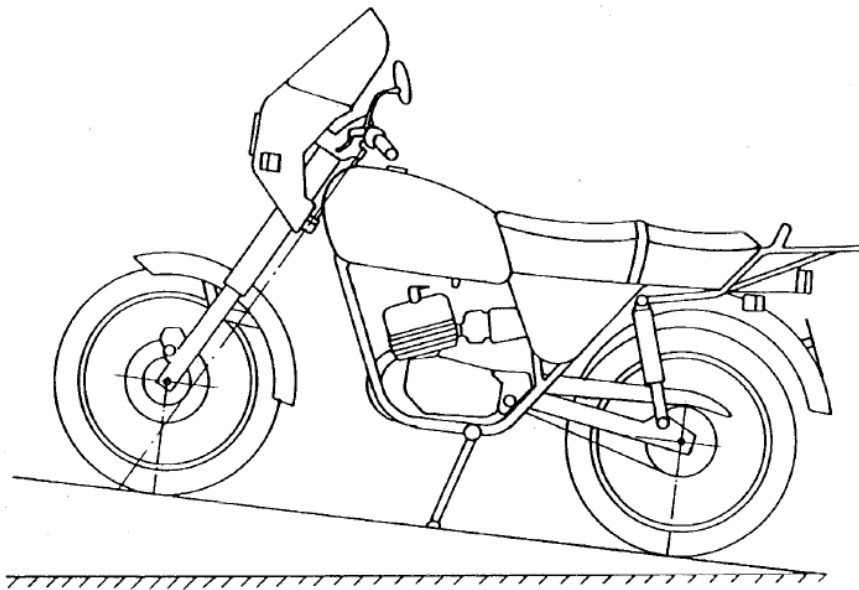
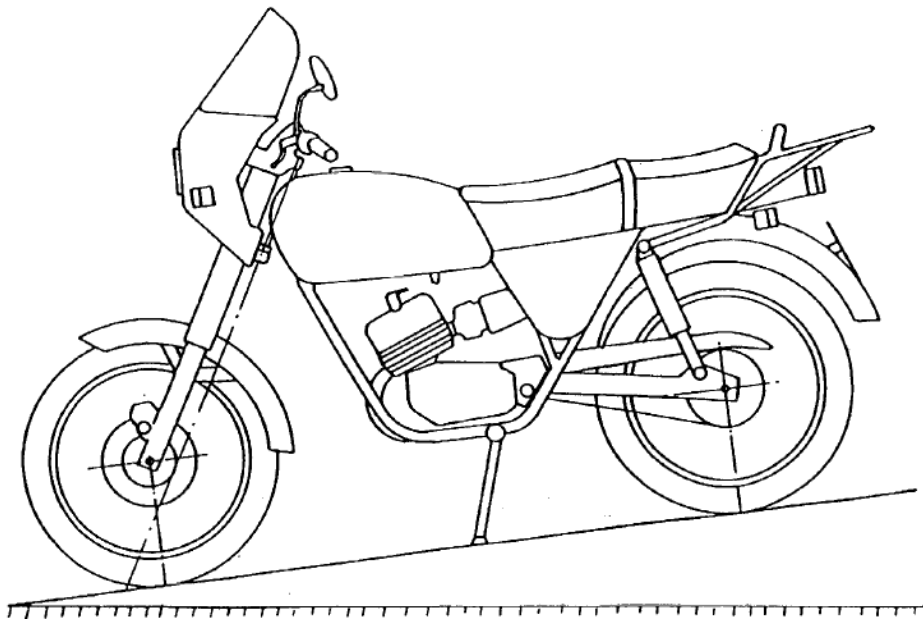

Figure 9 (b)
Slope – Downward inclination



- 8.31. First-aid kits
- It should be compulsory for motor vehicles of category D as defined in Annexes 6 and 7 to the 1968 Convention on Road Traffic, other than those used for urban services, to carry a first aid kit.
- 8.32. Harmonization of technical standards
- 8.32.1. When instituting a procedure for the preparation of any national regulation or for an amendment whose content does not conform to or embodies requirements additional to:
- (a) Those embodied in one or more UN Regulations annexed to the 1958 Agreement, and dealing with the same topic; or
 - (b) One or more Recommendations established by the World Forum in the sphere to which the proposed national regulation relates, Governments should inform the Executive Secretary of the Economic Commission for Europe of their intention as soon possible, so that the information can be communicated to the other countries concerned.
- 8.32.2. Governments of countries considering bringing into force, in the matter of the construction or equipment of road vehicles, a national regulation dealing with topics not referred to in the above-mentioned UN Regulations and Recommendations should inform the Executive Secretary thereof in the manner and for the purposes specified above.
- 8.32.3. Governments of countries bringing into force a regulation relating to questions which have not been dealt with by the World Forum or its subsidiary organs should so far as possible provide for a simple procedure for the amendment of such regulation so that it can, if this is deemed necessary, be brought promptly into conformity with such international recommendations or provisions as may subsequently be prepared on the same questions.
- 8.33. Measures to prevent the sale of unauthorized spare parts and equipments
- 8.33.1. For the purposes of this recommendation, "unauthorized parts or equipment" means any vehicle part or item of equipment covered directly or indirectly by a UN Regulation annexed to the 1958 Agreement concerning the Adoption of Uniform Conditions of Approval and Reciprocal Recognition of Approval for Motor Vehicle Equipment and Parts which:
- 8.33.1.1. Either, should bear the approval mark prescribed by that UN Regulation but which regularly:
 - 8.33.1.1.1. Does not bear the approval mark, even though such marking on the part or item of equipment concerned is compulsory under the national regulations of the country concerned; or
 - 8.33.1.1.2. Bears an approval mark which has never been issued; or
 - 8.33.1.1.3. Bears an approval mark which was issued to a manufacturer other than the actual manufacturer of the product; or
 - 8.33.1.1.4. Bears an approval mark issued to the manufacturer but for another product;

- 8.33.1.2. Or, while not required to bear the approval mark, has been recognized by a technical service responsible for approval tests as having a performance that is clearly inadequate, having regard to the requirements of the UN Regulation concerned and, if it bears a manufacturer's mark or trademark, has been denounced by the owner of such mark as an unauthorized product within the meaning of these Recommendations.
- 8.33.2. Governments made aware of the offer for sale within their country of parts or items of equipment not authorized under the approval UN Regulations shall take the following measures:
 - 8.33.2.1. Obtain proof of the infringement, either:
 - 8.33.2.1.1. In the case of paragraphs 8.33.1.1. and 8.33.1.2. above, by sampling at points of sale;
 - 8.33.2.1.2. In other cases (paragraphs 8.33.1.1.2. to 8.33.1.1.4. by reference to its own records or by request addressed to the administrative service of the country whose identifying number appears on the approval mark;
 - 8.33.2.1.3. If possible communicate to the competent administration(s) of the country of origin of the product (if it is not a Party to the 1958 Agreement) the information that an establishment in its country has offered for sale unauthorized parts or items of equipment;
 - 8.33.2.2. Inform the secretariat of the Economic Commission for Europe of the infringement, providing all information in its possession, and in particular:
 - 8.33.2.2.1. The description of the part or item of equipment;
 - 8.33.2.2.2. The approval mark (or absence of mark);
 - 8.33.2.2.3. The names and addresses of the manufacturer and/or the exporter; and
 - 8.33.2.2.4. The names and addresses of the importer and/or the distributor.
- 8.33.3. Once in possession of the particulars referred to above, the secretariat shall circulate the information:
 - 8.33.3.1. To the other Parties to the 1958 Agreement, and
 - 8.33.3.2. To the countries which, while not party to the Agreement, unilaterally apply the UN Regulation to which the unauthorized part or item of equipment is subject.
- 8.33.4. Governments made aware of the infringement either directly or through the information procedure provided for above shall:
 - 8.33.4.1. If possible take the necessary measures in accordance with their national law and without prejudice to any civil or criminal proceedings which might be initiated, to ensure that the unauthorized part or item of equipment:
 - 8.33.4.1.1. Is prevented from entering their respective countries; and
 - 8.33.4.1.2. Is withdrawn from the market if it has already been offered for sale.
 - 8.33.4.2. Inform the manufacturer of the product, if known, of the prohibition of the offering for sale of the unauthorized part or item of equipment in the territory of their respective countries.

- 8.34. Restriction on the sale of equipment, parts or accessories which have not been approved
- 8.34.1. When motor vehicle equipment, parts or accessories are subject to approval, it is dangerous to permit non-approved equipment, parts or accessories of the same kind to be offered to the public under a name similar to that of approved articles.
- 8.34.2. Governments which subject to approval certain items of equipment, parts or accessories for motor vehicles or for road-users (such as headlights, retro-reflectors, safety belts, crash helmets for motor cycles, etc.) should consider the possibility of prohibiting the offering for sale of non-approved equipment, parts or accessories of the same kind under a name liable to be confused with that of approved articles.
- 8.35. Restraint systems for adults
- It is recommended to apply the requirements of the UN Regulations listed in paragraph 5., the table, line K.
- 8.36. Rear marking plates on slow-moving/heavy/long vehicles
- It is recommended to apply the requirements of the UN Regulations listed in paragraph 4., the table, line K.
- 8.37. Protection of pedestrians and other vulnerable road users in the event of a (head-on) collision with a passenger car
- The following text is intended to provide motor vehicle manufacturers with guidelines concerning the design of future vehicle types and, in particular, the qualitative characteristics of the structure and deformation capacity of the front section of passenger cars; its purpose is to reduce as much as possible the severity of the injuries sustained by a person struck by the front of a vehicle travelling at a speed of up to 40 km/h.
- 8.37.1. Area of initial impact
- The area of initial contact with the legs of the person struck should be below and forward of the conventional bumper. It should extend over a vertical height sufficient to distribute the force over the legs, preferably below the knees of an adult person.
- 8.37.2. Front structure of the vehicle
- 8.37.2.1. The rear third of the bonnet, the windscreen frame and the front pillars (A) should receive particular attention as regards both their energy-absorption capacity and their form.
- It should not be possible for the head to strike the windscreen-wiper pivots. Should such contact be possible, the windscreen-wiper pivots shall have a suitable protective covering.
- 8.37.2.2. The bonnet leading edge should be such that the impact should not be against a hard edge but against a structure which is sufficiently large and if possible energy-absorbent.
- 8.37.2.3. An adequate deformation of the front third of the bonnet would, in particular, reduce the severity of head injuries to children.
- 8.37.2.4. Rigid parts located under the bonnet should be placed some distance back so as to allow sufficient deformation of the bonnet on impact.

- 8.37.3. Headlamps and other lamps
Headlamps and other front lamps should not have rigid projecting frames. If possible, they should be mounted slightly recessed in the bodywork.
- 8.37.4. Accessories
External accessories (trimmings, spoilers, etc.) should be deformable, retractable or detachable so as to minimize the risk of injury. In the latter cases, these recommendations shall also apply to the residual parts.
- 8.37.5. Structural elements
- 8.37.5.1. Preference should be given to structures with adequate energy-absorption capacity.
- 8.37.5.2. The curvature radius of parts of the vehicle which may be impacted should be as large as possible, with due account being taken of technical requirements.
- 8.38. Methods and instruments for measuring noise inside motor vehicles
- 8.38.1. Measuring instruments
- 8.38.1.1. An omnidirectional sound level meter of high precision complying at least with the specifications of Publication No. 651 [1979] "Precision sound level meters" of the International Electro technical Commission (IEC) concerning the characteristics of sound level meters shall be used. Measurement shall be carried out with frequency weighting A and time weighting F conforming to curve A and the "fast response" time respectively. The type of sound level meter shall be stated in the test report.
- 8.38.1.2. The sound level meter shall be calibrated against a sound pressure calibrator immediately before and after each series of test runs. If the meter readings obtained from these calibrations differ by more than 1 dB, the test shall be considered invalid.
- 8.38.1.3. A suitable wind shield may be used to reduce the influence of wind on the measurements in open vehicles. Wind shields recommended by the sound level meter manufacturer will generally be suitable.
- 8.38.1.4. If alternative measuring equipment, including, for example, a tape recorder and/or level recorder, is used, its overall electro-acoustic performance shall conform to the relevant provisions of IEC Publication 651 [1979] for class I instruments.

If a tape-recorder is used as part of the measuring equipment, it may be necessary to include suitable additional pre-emphasis and de-emphasis circuits for recording and reproduction to provide an adequate signal-to-noise ratio over the whole frequency range concerned.
- 8.38.1.5. The rotational speed of the engine shall be measured by an independent tachometer whose accuracy is within 3 per cent of the actual speed of rotation.
- 8.38.2. Measured quantities
- 8.38.2.1. All readings of the sound level meter are to be taken with time weighting F
- 8.38.2.2. The values to be measured at all microphone positions during type and monitoring tests are A-weighted sound pressure levels, LpA, expressed in decibels (dB). If the weighting curve used is not stated, the measured values shall be expressed in dB (A).

- 8.38.3. Conditions of measurement
 - 8.38.3.1. Site
 - 8.38.3.1.1. The test site shall be such that the sound radiated by the vehicle to the outside contributes to the inside noise only by reflections from the road surface and not by reflections from buildings, walls or similar large objects outside the vehicle. During the period of measurement, the distance of the vehicle from large objects shall be greater than 20 m.
 - 8.38.3.1.2. The ambient air temperature in which the vehicle is operating shall be in the range -5 to +35 °C. The wind speed along the test track at a height of approximately 1.2 m shall not exceed 5 m/s. The other meteorological conditions shall be such that they do not influence the measurements. The speed of the wind and the direction of the wind relative to the test track shall be stated in the test report.
 - 8.38.3.1.3. For all measurements of A-weighted sound pressure levels the lower limit of the dynamic range set by the background noise level and by the inherent noise level of the measuring equipment shall be at least 10 dB below the A-weighted sound pressure levels of the vehicle noise.
 - 8.38.3.1.4. The test road shall be hard and as smooth and level as possible, without gaps or ripples or similar macro-irregularities of surface texture which might contribute to the sound levels inside the motor vehicle. The surface shall be dry and free from snow, dust, stones, leaves, etc.
 - 8.38.3.2. Vehicle
 - 8.38.3.2.1. Engine and tyre conditions.
 - 8.38.3.2.1.1. During the test, all operating conditions of the engine shall correspond to the specifications given by the manufacturer, for example, fuel, lubricating oil, timing of ignition or fuel injection pump for the test conditions. The engine shall be stabilized at its normal operating temperature immediately before commencing the test, e.g., by driving the vehicle for an adequate distance at a medium speed.
 - 8.38.3.2.1.2. The tyres used shall be of a type specified by the vehicle manufacturer. If the use of off-road tyres is optional, tyres for road use shall be fitted. The tyres shall be nearly new, but with a minimum wear of 300 km. The type of tyres and inflation pressures at the time of testing shall be stated in the test report. The wheels of the vehicles should be statically and dynamically balanced if it is considered that wheels that are out of balance may affect the noise level inside the vehicle.
 - 8.38.3.2.1.3. If the engine coolant radiators are equipped with devices such as flaps, the measurements shall be carried out with them open. Standard test conditions are with fan operating normally; if a vehicle is fitted with an automatic flap and/or fan, its operating conditions shall be stated in the test report.
 - 8.38.3.2.2. Loading of the vehicle
 - 8.38.3.2.2.1. The vehicle shall be unladen. In the cabs of trucks and similar vehicles, not more than two persons (the driver and observer) shall be allowed, and in public service vehicles with more than eight seats not more than three persons shall be allowed.

- 8.38.3.2.3. Openings, windows, auxiliary equipment
- Openings such as skylights, all windows and ventilating inlets and/or outlets shall be closed, if possible. Auxiliary equipment such as windscreen wipers and heating and/or ventilating fans and air-conditioners shall not operate during the tests. If any auxiliary equipment is automatic, its operating condition shall be stated in the test report.
- 8.38.4. Methods of testing
- 8.38.4.1. General conditions of tests
- 8.38.4.1.1. At least two measurements shall be made at each microphone position and for each operating condition. If the spread of results of the A-weighted sound pressure level obtained under any measuring condition exceeds 3 dB, further measurements shall be made until the readings of two independent successive measurements fall within a range of 3 dB(A); the mean value of these two readings shall be taken as the test result.
- 8.38.4.1.2. The value stated in the test report shall be rounded to the nearest whole decibel.
- 8.38.4.1.3. Any peak which is obviously out of character with the general sound level being read shall be disregarded.
- 8.38.4.1.4. Whenever the sound level meter reading fluctuates, the mean value of the readings shall be determined. Occasional extreme peaks shall be disregarded.
- 8.38.4.1.5. The presence of clearly audible pure tones or noise of distinct impulse character shall be stated additionally in the test report.
- 8.38.4.2. Acceleration test
- 8.38.4.2.1. The procedure for the test is as follows:
- The speed of the vehicle and of the engine shall be stabilized at the specified initial conditions.
- When stable conditions are attained, the throttle shall be fully opened as fast as possible and held in this position until either 90 per cent of the engine speed for maximum power as specified by the manufacturer of the vehicle ("maximum power speed") or 100 km/h is reached, whichever is lower.
- 8.38.4.2.2. The initial operating conditions are specified as follows:
- 8.38.4.2.2.1. Vehicle with a manually-operated gear box
- 8.38.4.2.2.1.1. If the vehicle is fitted with a manually-operated gear box, it shall be in the highest gear with which the test is possible without exceeding 120 km/h; the gear setting shall not be changed during the test.
- 8.38.4.2.2.1.2. If, at an engine speed of 90 per cent of maximum power speed, a road speed of 120 km/h is exceeded in top gear, a lower gear shall be selected, but not lower than third for a four-speed or more than four-speed gearbox, and not lower than second for a three-speed gear-box. If 120 km/h is still exceeded in this lower gear, the vehicle shall be tested over the speed range 60 to 120 km/h in that gear.

- 8.38.4.2.2.1.3. The initial engine speed shall be the lowest allowing a continuously increasing engine speed during the test, but not lower than 45 per cent of the maximum power speed, unless 120 km/h is exceeded at 90 per cent of maximum power speed in the lowest gear allowed, in which case the initial engine speed shall be that corresponding to a road speed of 60 km/h.
- 8.38.4.2.3. Automatic transmission vehicle
- 8.38.4.2.3.1. For vehicles with automatic transmission, the initial engine speed shall be stabilized as near as possible to 45 per cent of the maximum power speed. The corresponding road speed shall be not higher than approximately 60 km/h.
- 8.38.4.2.4. If the setting changes before the final speed of 90 per cent of maximum power speed or 120 km/h is reached, the initial speed shall be 50 per cent of the speed at which the setting changes. If possible, kick-down mechanisms shall be made inoperative.
- 8.38.4.2.5. At full throttle acceleration, the maximum LpA value occurring in the specified acceleration range shall be recorded and stated in the test report, in accordance with provisions of paragraph 8.38.4.1. above.
- 8.38.4.3. Stationary test
- 8.38.4.3.1. Stationary tests shall be carried out in neutral gear with the engine operating at the idling speed indicated by the manufacturer.
- 8.38.4.3.2. The LpA values measured under the conditions stated in paragraph 8.38.4.3.1. above constitute the result of the measurement and shall be stated in the test report.
- 8.38.5. Microphone position
- 8.38.5.1. Microphone position in the vehicle
- 8.38.5.1.1. During the measurement no seat at which measurement is being made in the vehicle shall be occupied, with the exception of the driver's seat.
- 8.38.5.1.2. The microphone shall not be closer than 0.15 m to walls, upholstery or persons present. If an assistant is present during the measurement (see paragraph 8.38.6.2.), the assistant shall keep at a minimum distance of 1 m from the microphone.
- 8.38.5.1.3. The microphone shall be oriented horizontally, with the axis of maximum sensitivity (according to the manufacturer's specification) pointing in the direction in which a person occupying the seat or standing position would be looking or, if such direction is not specified, in the driving direction.
- 8.38.5.2. Microphone position in relation to a seat: Setting of seats and head-restraints (see Figure 10 below)
- 8.38.5.2.1. For the positioning of the microphone, in accordance with the conditions set out below, adjustable seats and head-restraints shall be set in the mid-position of the horizontal and vertical range of adjustment. If the back-rest of the seat is adjustable, this shall be set as near vertical as possible.
- 8.38.5.2.1.1. The vertical co-ordinate of the microphone shall be 0.7 ± 0.05 m above the intersection of the unoccupied seat surface and the surface of the back of the seat.

- 8.38.5.2.1.2. The horizontal co-ordinate shall be:
- 8.38.5.2.1.2.1. For an unoccupied seat (position A), the median plane (plane of symmetry) of the seat;
- 8.38.5.2.1.2.2. For the driver's seat, with the driver present (position B), 0.2 ± 0.02 m to the right (to the left for right-hand drive vehicles) of the median plane of the seat.
- 8.38.5.2.2. In case of doubt, a check may be made in relation to the H point of the seat. The H point is a reference point determined according to the procedure described in UN Regulation No. 46, Annex 8.⁸
- 8.38.5.2.2.1. For the determination of the H point, the reference line on the manikin described in UN Regulation No. 46, Annex 8, is the line shown in Figure 11 below.
- The reference line is a straight line which, either on a test manikin having the weight and dimensions of a fiftieth-percentile adult male or on a test manikin having identical characteristics passes through the joint of the leg with the pelvis and the joint of the neck with the thorax.
- 8.38.5.2.2.2. The microphone shall be placed 0.7 ± 0.05 m above the H point of the unoccupied seat, as measured on the reference line (see Figure 11 below).
- 8.38.5.2.2.3. The horizontal co-ordinate of the microphone shall be the median plane (plane of symmetry) of the unoccupied seat. At the driver's seat the horizontal co-ordinate shall be 0.2 ± 0.02 m to the right (to the left for right-hand drive vehicles) of the median plane of the seat.
- 8.38.5.2.2.4. If the vehicle seats are equipped with head-restraints, the distance of the microphone from the head-restraint centre shall be 0.1 ± 0.02 m.
- 8.38.5.3. Microphone position for standing places.
- The vertical co-ordinate shall be 1.6 ± 0.1 m above the floor. The horizontal co-ordinate shall correspond to a person standing at selected points.
- 8.38.6. Measuring position selection
- 8.38.6.1. Measurements shall be made:
- 8.38.6.1.1. At the driver's seat;
- 8.38.6.1.2. At the permanently-used service seats (e.g., conductor's seat).
- 8.38.6.2. The other measuring positions shall be:
- 8.38.6.2.1. On vehicles with a maximum of three rows of seats, in the last row in the axis of the seat which is nearest to the longitudinal axis of the vehicle (passenger compartment), preferably on the right-hand side in case of left-hand steered vehicles;

⁸ *Note by the secretariat:* The procedure for determining the "H" point is now reproduced in Annex 1 to this Resolution.

- 8.38.6.2.2. On vehicles having nine or more seats (in addition to the driver's seat), in the first row behind the driver's seat and in the last row of seats in the axis of the seat which is nearest to the longitudinal axis of the vehicle, preferably on the right-hand side in case of left-hand steered vehicles. If there are more than three rows of seats behind the driver's seat, also in the row which is nearest to the middle point between the first and last row.⁹
- 8.38.6.2.3. In the area intended for standing passengers, on additional suitably selected places according to the individual layout of the vehicle, on the longitudinal axis of the vehicle or on the position nearest to this axis (preferably on the right-hand side for left-hand steered vehicles).
- 8.38.6.3. The exact positions of the measuring points shall be identified in the schematic drawing.

Figure 10

Microphone position with respect to a seat

(See paragraphs 8.38.5.2.1.2.1. and 8.38.5.2.1.2.2.)

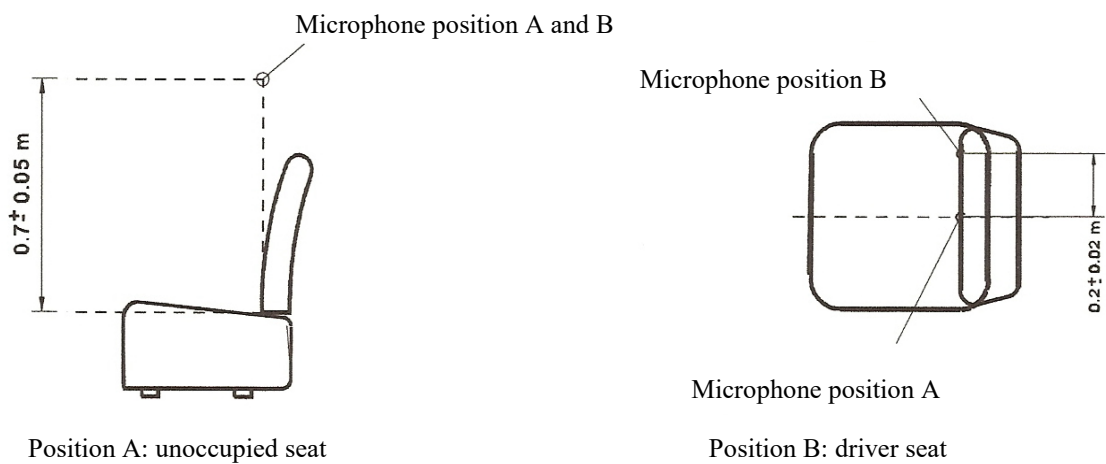

⁹ The test laboratory may choose for vehicles of this category additional measuring points at the middle and the rear of the vehicle adjacent to the longitudinal axis of the vehicle.

Figure 11
Microphone position with respect to a seat
(See paragraphs 8.38.5.2.2.1. and 8.38.5.2.2.2.)

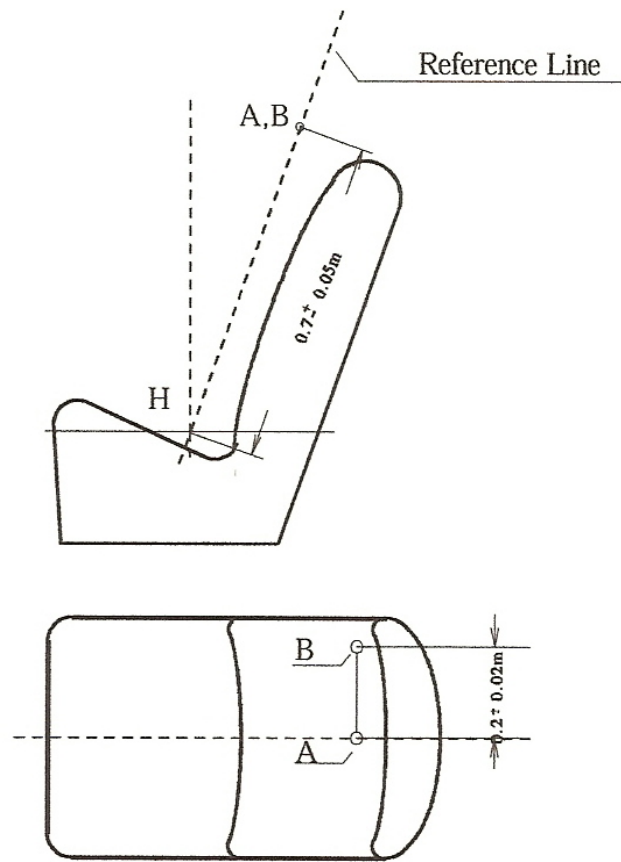

8.39. Passenger protection against displacement luggage

It is recommended to apply the requirements of the UN Regulations listed in paragraph 5., the table, line Q.

Annex 1

Standard annex on the procedure for determining the "H" point and the actual torso angle for seating positions in motor vehicles*

1. Purpose
The procedure described in this annex is used to establish the "H" point location and the actual torso angle for one or several seating positions in a motor vehicle and to verify the relationship of measured data to design specification given by the vehicle manufacturer.¹
2. Definitions
For the purposes of this annex:
 - 2.1. "Reference data" means one or several of the following characteristics of a seating position:
 - 2.1.1. The "H" point and the "R" point and their relationship;
 - 2.1.2. The actual torso angle and the design torso angle and their relationship.
 - 2.2. "Three-dimensional] H-point machine" (3-D "H" point machine) means the device used for the determination of "H" points and actual torso angles. This device is described in Appendix 1 to this annex.
 - 2.3. "H" point means the pivot centre of the torso and thigh of the 3-D H machine installed in the vehicle seat in accordance with the procedure described in paragraph 4. below. The "H" point is located in the centre of the centre line of the device which is between the 'H' point sight buttons on either side of the 3-D H machine. The "H" point corresponds theoretically to the "R" point (for tolerances, see paragraph 3.2.2. below). Once determined in accordance with the procedure described in paragraph 4., the "H" point is considered as fixed in relation to the seat-cushion structure and as moving with it when the seat is adjusted.
 - 2.4. "R" point or "seating reference point" means a design point defined by the vehicle manufacturer for each seating position and established with respect to the three-dimensional reference system.
 - 2.5. "Torso line" means the centre line of the probe of the 3-D H machine with the probe in the fully rearward position.

* The text of this "standard annex" appears, with almost the same text, in several (more than three) Regulations and Rules. The aim of its insertion in this document is to permit to replace their reproduction *in extenso* in the Regulations. The original numbering of paragraphs has been kept in order to show their relation with Regulations and Rules in which they appear.

¹ In any seating position other than front seats where the "H" point cannot be determined using the "three-dimensional H-point machine" or other procedures, the "R" point indicated by the vehicle manufacturer may be taken as a reference at the discretion of the Type Approval Authority.

- 2.6. "Actual torso angle" means the angle measured between a vertical line through the "H" point and the torso line using the back angle quadrant on the 3-D H machine. The actual torso angle corresponds theoretically to the design torso angle (for tolerances, see paragraph 3.2.2. below).
- 2.7. "Design torso angle" means the angle measures between a vertical line through the "R" point and the torso line in a position which corresponds to the design position of the seat-back established by the vehicle manufacturer;
- 2.8. "Centre plane of occupant" (C/LO) means the median plane of the 3-D H machine positioned in each designated seating position; it is represented by the co-ordinate of the "H" point on the "Y" axis. For individual seats, the centre plane of the seat coincides with the centre plane of the occupant. For other seats, the centre plane of the occupant is specified by the manufacturer;
- 2.9. "Three-dimensional reference system" means a system as described in Appendix 2 to this annex;
- 2.10. "Fiducial marks" are physical points (holes, surfaces, marks or indentations) on the vehicle body as defined by the manufacturer;
- 2.11. "Vehicle measuring attitude" means the position of the vehicle as defined by the co-ordinates of fiducial marks in the three-dimensional reference system.
3. Requirements
- 3.1. Data presentation
- For each seating position where reference data are required in order to demonstrate compliance with the provisions of the corresponding UN Regulation, all or an appropriate selection of the following data shall be presented in the form indicated in Appendix 3 to this annex:
- 3.1.1. The co-ordinates of the "R" point relative to the three-dimensional reference system;
- 3.1.2. The design torso angle;
- 3.1.3. All indications necessary to adjust the seat (if it is adjustable) to the measuring position set out in paragraph 4.3. below.
- 3.2. Relationship between measured data and design specifications
- 3.2.1. The coordinates of the "H" point and the value of the actual torso angle obtained by the procedure set out in paragraph 4. below shall be compared, respectively, with the coordinates of the "R" point and the value of the design torso angle indicated by the vehicle manufacturer.
- 3.2.2. The relative positions of the "R" point and the "H" point and the relationship between the design torso angle and the actual torso angle shall be considered satisfactory for the seating position in question if the "H" point, as defined by its coordinates, lies within a square of 50 mm side length with horizontal and vertical sides whose diagonals intersect at the "R" point, and if the actual torso angle is within 5° of the design torso angle.
- 3.2.3. If these conditions are met, the "R" point and the design torso angle shall be used to demonstrate compliance with the provisions of the corresponding UN Regulation;

- 3.2.4. If the "H" point or the actual torso angle does not satisfy the requirements of paragraph 3.2.2. above, the "H" point and the actual torso angle shall be determined twice more (three times in all). If the results of two of these three operations satisfy the requirements, the conditions of paragraph 3.2.3. above shall apply;
- 3.2.5. If the results of at least two of the three operations described in paragraph 3.2.4. above do not satisfy the requirements of paragraph 3.2.2. above, or if the verification cannot take place because the vehicle manufacturer has failed to supply information regarding the position of the "R" point or regarding the design torso angle, the centroid of the three measured points or the average of the three measured angles shall be used and be regarded as applicable in all cases where the "R" point or the design torso angle is referred to in the corresponding UN Regulation.
4. Procedure for "H" point and actual torso angle determination
- 4.1. The vehicle shall be preconditioned, at the manufacturer's discretion, at a temperature of 20 °C + 10 °C to ensure that the seat material reaches room temperature. If the seat to be checked has never been sat upon, a 70 to 80 kg person or device shall sit on the seat twice for one minute to flex the cushion and back. At the manufacturer's request, all seat assemblies shall remain unloaded for a minimum period of 30 minutes prior to installation of the 3-D H machine.
- 4.2. The vehicle shall be in the measuring attitude defined in paragraph 2.11. above.
- 4.3. The seat, if it is adjustable, shall be adjusted first to the rearmost normal driving or riding position, as indicated by the vehicle manufacturer, taking into consideration only the longitudinal adjustment of the seat, excluding seat travel used for purposes other than normal driving or riding positions. Where other modes of seat adjustment exist (vertical, angular, seat-back, etc.), these will then be adjusted to the position specified by the vehicle manufacturer. For suspension seats, the vertical position shall be rigidly fixed corresponding to a normal driving position as specified by the manufacturer.
- 4.4. The area of the seating position taken up by the 3-D H machine shall be covered by a muslin cotton, of sufficient size and appropriate texture, described as a plain cotton fabric having 18.9 threads per cm² and weighing 0.228 kg/m², or knitted or non-woven fabric having equivalent characteristics.
- If the test is performed on a seat outside the vehicle, the floor on which the seat is placed shall have the same essential characteristics² as the floor of the vehicle in which the seat is intended to be used.
- 4.5. Place the seat and back assembly of the 3-D H machine so that the centre plane of the occupant (CPO) coincides with the centre plane of the 3-D H machine. At the manufacturer's request, the 3-D H machine may be moved inboard with respect to the CPO if the 3-D H machine is located so far outboard that the seat edge will not permit levelling of the 3-D H machine.

² Tilt angle, height difference with a seat mounting, surface texture, etc.

- 4.6. Attach the foot and lower leg assemblies to the seat-pan assembly, either individually or by using the T-bar and lower leg assembly. The line through the "H" point sight buttons shall be parallel to the ground and perpendicular to the longitudinal centre plane of the seat.
- 4.7. Adjust the feet and leg positions of the 3-D H machine as follows:
 - 4.7.1. Designated seating position: driver and outside front passenger
 - 4.7.1.1. Both feet and leg assemblies shall be moved forward in such a way that the feet take up natural positions on the floor, between the operating pedals if necessary. Where possible the left foot shall be located at approximately the same distance to the left of the centre plane of the 3-D H machine as the right foot is to the right. The spirit level verifying the transverse orientation of the 3-D H machine is brought to the horizontal by readjustment of the seat pan if necessary, or by adjusting the leg and foot assemblies towards the rear. The line passing through the "H" point sight buttons shall be maintained perpendicular to the longitudinal centre plane of the seat.
 - 4.7.1.2. If the left leg cannot be kept parallel to the right leg and the left foot cannot be supported by the structure, move the left foot until it is supported. The alignment of the sight buttons shall be maintained.
 - 4.7.2. Designated seating position: outboard rear seat

For rear seats or auxiliary seats, the legs are located as specified by the manufacturer. If the feet then rest on parts of the floor which are at different levels, the foot which first comes into contact with the front seat shall serve as a reference and the other foot shall be so arranged that the spirit level giving the transverse orientation of the seat of the device indicates the horizontal.
 - 4.7.3. Other designated seating positions:

The general procedure indicated in paragraph 4.7.1. above shall be followed, except that the feet shall be placed as specified by the vehicle manufacturer.
- 4.8. Apply lower leg and thigh weights and level the 3-D H machine.
- 4.9. Tilt the back pan forward against the forward stop and draw the 3-D H machine away from the seat-back using the T-bar. Reposition the 3-D H machine on the seat by one of the following methods:
 - 4.9.1. If the 3-D H machine tends to slide rearward, use the following procedure. Allow the 3-D H machine to slide rearward until a forward horizontal restraining load on the T-bar is no longer required, i.e. until the seat pan contacts the seat-back. If necessary, reposition the lower leg.
 - 4.9.2. If the 3-D H machine does not tend to slide rearward, use the following procedure. Slide the 3-D H machine rearward by applying a horizontal rearward load to the T-bar until the seat pan contacts the seat-back (see Figure 2 of the Appendix 1 to this annex).
- 4.10. Apply a 100 ± 10 N load to the back and pan assembly of the 3-D H machine at the intersection of the hip angle quadrant and the T-bar housing. The direction of load application shall be maintained along a line passing through the above intersection to a point just above the thigh bar housing

(see Figure 2 of Appendix 1 to this annex). Then carefully return the back pan to the seat-back. Care shall be exercised throughout the remainder of the procedure to prevent the 3-D H machine from sliding forward.

- 4.11. Install the right and left buttock weights and then, alternately, the eight torso weights. Maintain the 3-D H machine level.
- 4.12. Tilt the back pan forward to release the tension on the seat-back. Rock the 3-D H machine from side to side through a 10° arc (5° to each side of the vertical centre plane) for three complete cycles to release any accumulated friction between the 3-D H machine and the seat.

During the rocking action, the T-bar of the 3-D H machine may tend to diverge from the specified horizontal and vertical alignment. The T-bar shall therefore be restrained by applying an appropriate lateral load during the rocking motions. Care shall be exercised in holding the T-bar and rocking the 3-D H machine to ensure that no inadvertent exterior loads are applied in a vertical or fore and aft direction.

The feet of the 3-D H machine are not to be restrained or held during this step. If the feet change position, they should then be allowed to remain in that attitude for the moment.

Carefully return the back pan to the seat-back and check the two spirit levels for zero position. If any movement of the feet has occurred during the rocking operation of the 3-D H machine, they shall be repositioned as follows:

Alternately, lift each foot off the floor the minimum necessary amount until no additional foot movement is obtained. During this lifting, the feet are to be free to rotate; no forward or lateral loads are to be applied. When each foot is placed back in the down position, the heel is to be in contact with the structure designed for this.

Check the lateral spirit level for zero position; if necessary, apply a lateral load to the top of the back pan sufficient to level the 3-D H machine's seat pan on the seat.

- 4.13. Holding the T-bar to prevent the 3-D H machine from sliding forward on the seat cushion, proceed as follows:
 - (a) Return the back pan to the seat-back,
 - (b) Alternately apply and release a horizontal rearward load, not to exceed 25 N, to the back angle bar at a height approximately at the centre of the torso weights until the hip angle quadrant indicates that a stable position has been reached after load release. Care should be taken to ensure that no exterior downward or lateral loads are applied to the 3-D H machine. If another level adjustment of the 3-D H machine is necessary, rotate the back pan forward, re-level, and repeat the procedure from paragraph 4.12.
- 4.14. Take all measurements:
 - 4.14.1. The coordinates of the "H" point are measured with respect to the three-dimensional reference system.
 - 4.14.2. The actual torso angle is read at the back angle quadrant of the 3-D H machine with the probe in its fully rearward position.

- 4.15. If a rerun of the installation of the 3-D H machine is desired, the seat assembly shall remain unloaded for a minimum period of 30 minutes prior to the re-run. The 3-D H machine shall not be left loaded on the seat assembly longer than the time required to perform the test.
- 4.16. If the seats in the same row can be regarded as similar (bench seat, identical seats, etc.) only one "H" point and one actual torso angle shall be determined for each row of seats, the 3-D H machine described in the Appendix 1 to this annex being seated in a place regarded as representative for the row.
- This place shall be:
- 4.16.1. In the case of the front row, the driver's seat.
- 4.16.2. In the case of the rear row or rows, an outer seat.

Annex 1 - Appendix 1

Description of the three-dimensional "H" point machine (3-D H machine)¹

1. Back and seat pans

The back and seat pans are constructed of reinforced plastic and metal; they simulate the human torso and thigh and are mechanically hinged at the "H" point. A quadrant is fastened to the probe hinged at the "H" point to measure the actual torso angle. An adjustable thigh bar, attached to the seat pan, establishes the thigh centre line and serves as a baseline for the hip angle quadrant.
2. Body and leg elements

Lower leg segments are connected to the seat pan assembly at the T-bar joining the knees, which is a lateral extension of the adjustable thigh bar. Quadrants are incorporated in the lower leg segments to measure knee angles. Shoe and foot assemblies are calibrated to measure the foot angle. Two spirit levels orient the device in space. Body element weights are placed at the corresponding-centres of gravity to provide seat penetration equivalent to a 76 kg male. All joints of the 3-D H machine should be checked for free movement without encountering any noticeable friction.

¹ The machine corresponds to that described in ISO Standard 6549-1980. For details of the construction of the 3-DH machine refer to Society of Automotive Engineers (SAE), 400 Commonwealth Drive, Warrendale, Pennsylvania 15096, United States of America.

Figure 1
3-D H Machine elements designation

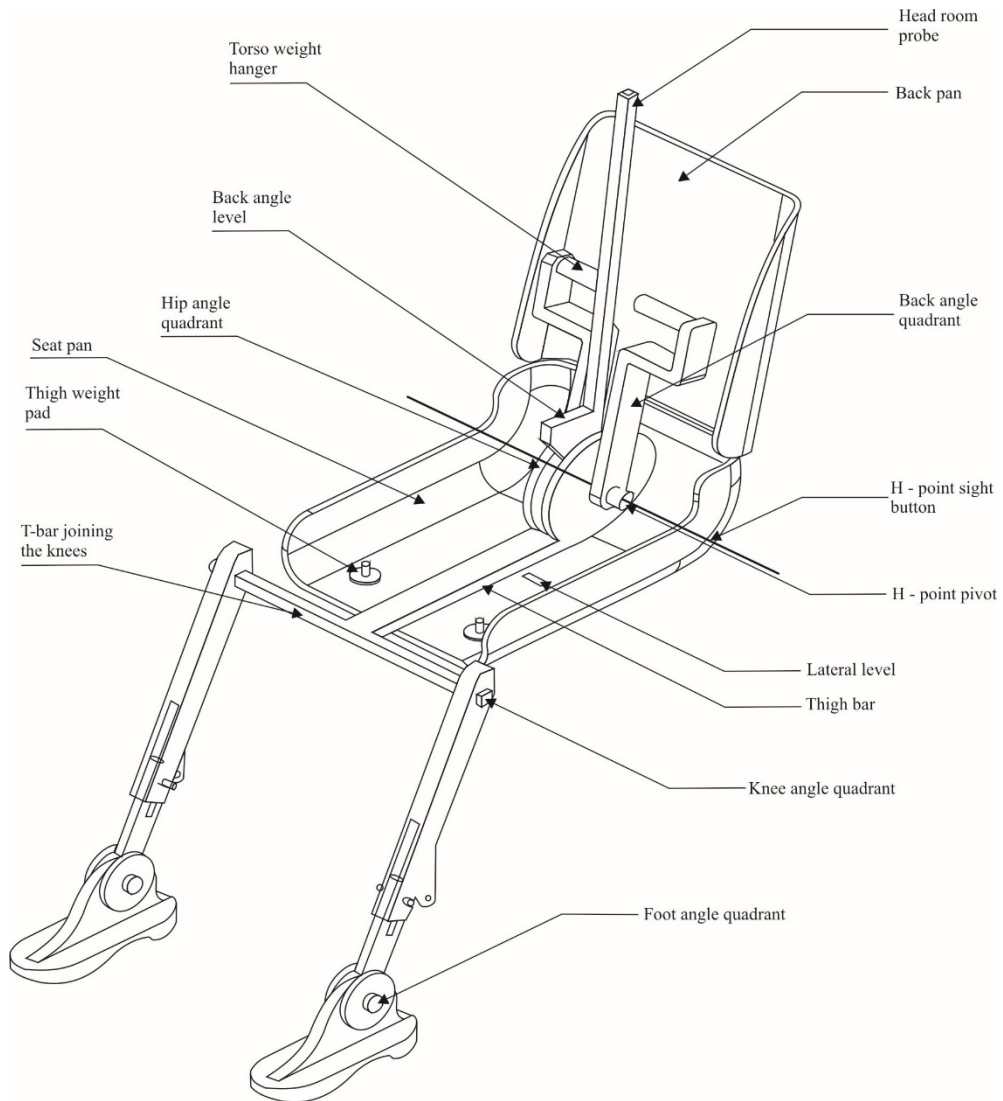
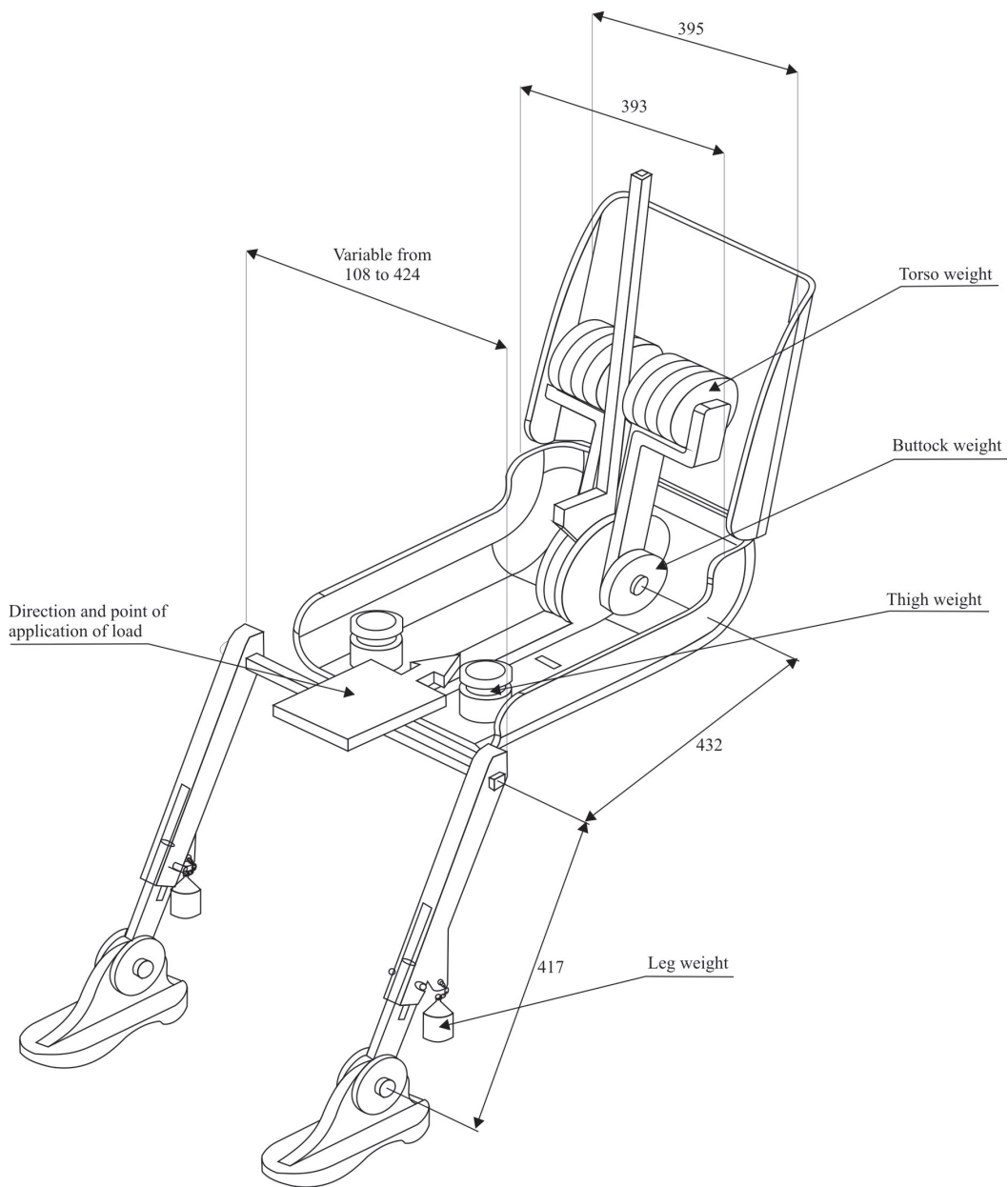

Figure 2
Dimensions of the 3-D H- machine elements and load distribution



Annex 1 - Appendix 2

Three-dimensional reference system

1. The three-dimensional reference system is defined by three orthogonal planes established by the vehicle manufacturer (see Figure).¹
2. The vehicle measuring attitude is determined by positioning the vehicle on a supporting surface such that the co-ordinates of the fiducial marks correspond to the values indicated by the manufacturer.
3. The coordinates of the "R" point and the "H" point are established in relation to the fiducial marks defined by the vehicle manufacturer.

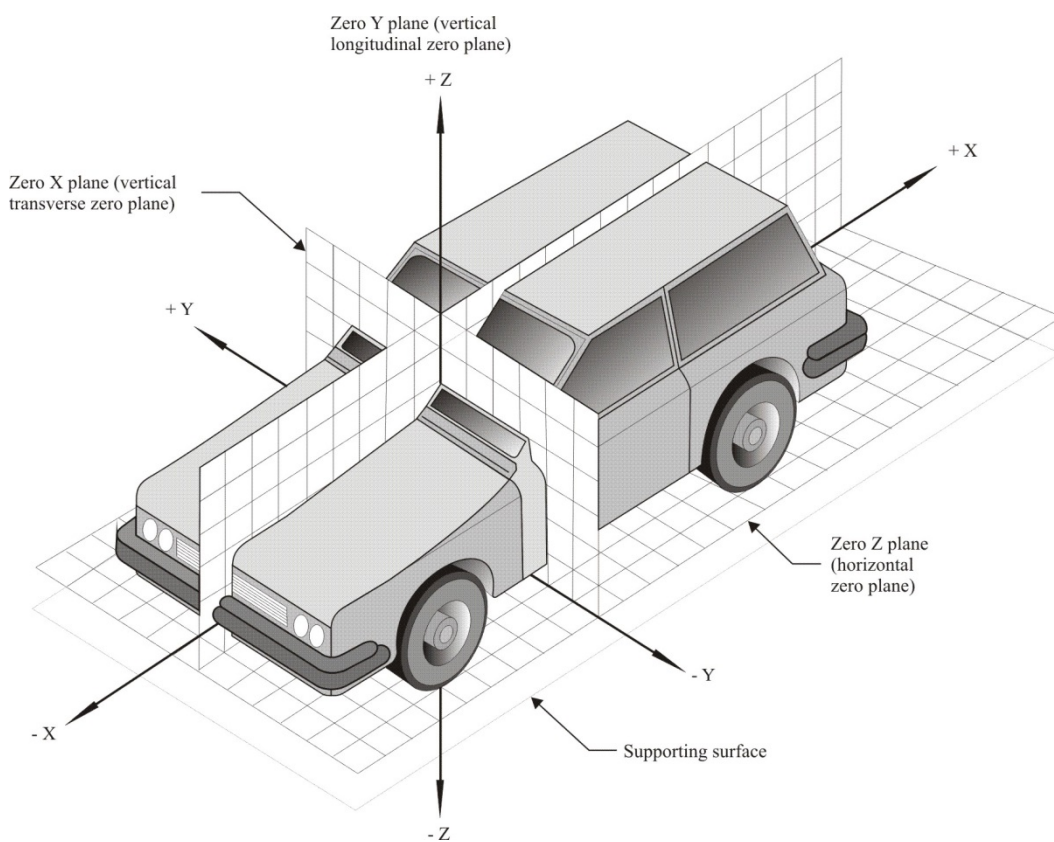

¹ The reference system corresponds to ISO Standard 4130:1978

Annex 1 - Appendix 3

Reference data concerning seating positions

1. Coding of reference data
Reference data are listed consecutively for each seating position. Seating positions are identified by a two-digit code. The first character is an Arabic numeral and designates the row of seats, counting from the front to the rear of the vehicle. The second digit is a capital letter which designates the location of the seating position in a row, as viewed in the direction of forward motion of the vehicle; the following letters shall be used:
L = left,
C = centre,
R = right.
2. Description of vehicle measuring attitude
 - 2.1. Coordinates of fiducial marks
X
Y
Z
3. List of reference data
 - 3.1. Seating position:
 - 3.1.1. Coordinates of the "R" point:
X
Y
Z
 - 3.1.2. Design torso angle:
 - 3.1.3. Specifications for seat adjustment:¹
Horizontal:
Vertical:
Angular:
Torso angle:

Note: List reference data for further seating positions under paragraphs 3.2., 3.3., etc.

¹ Strike out what does not apply.

Annex 2

Guidelines on measures ensuring the audibility of hybrid and electric vehicles

Preamble

The environmental benefits expected to be achieved by hybrid electric and pure electric road transport vehicles (HEV and EV) have resulted in vehicles becoming quiet. This has resulted in the removal of an important source of audible signal that is used by pedestrians (e.g. blind and low vision pedestrians) and road users (e.g. cyclists), to signal the approach, presence or departure of these vehicles.

The guideline is intended to present recommendations to manufacturers for a system to be installed in vehicles to provide vehicle operation information to pedestrians and vulnerable road users.

This guideline is intended as interim guidance until the completion of on-going research activities and the development of globally harmonized device performance specifications.

Scope

This guideline addresses Acoustic Vehicle Alerting System (AVAS) for hybrid electric and pure electric road transport vehicles (HEV and EV).

A. Acoustic Vehicle Alerting System

1. Definition

Acoustic Vehicle Alerting System (AVAS) is a sound generating device designed to inform pedestrians and vulnerable road users.

2. System performance

AVAS is intended to be fitted to a vehicle.

AVAS shall fulfil the requirements set forth below.

3. Operation conditions

(a) Sound generation method

The AVAS shall automatically generate a sound in the minimum range of vehicle speed from start up to approximately 20 km/h and during reversing, if applicable for that vehicle category. In case the vehicle is equipped with an internal combustion engine that is in operation within the vehicle speed range defined above, the AVAS may not need to generate a sound.

For vehicles having a reversing sound warning device, it is not necessary for the AVAS to generate a sound during backup.

(b) Pause switch

The AVAS may have a switch to stop its operation temporarily ("pause switch").

If a pause switch is introduced, however, the vehicle should also be equipped with a device for indicating the pause state of the vehicle-approach informing device to the driver in the driver's seat.

The AVAS should remain capable of re-operating after stopped by a pause switch.

If fitted in the vehicle, a pause switch should be located in such a position that the driver will find and manipulate it with ease.

(c) Attenuation

The AVAS sound level may be attenuated during periods of vehicle operation.

4. Sound type and volume

(a) The sound to be generated by the AVAS should be a continuous sound that provides information to the pedestrians and vulnerable road users of a vehicle in operation.

However, the following and similar types of sounds are not acceptable:

- (i) Siren, horn, chime, bell and emergency vehicle sounds;
- (ii) Alarm sounds e.g. fire, theft, smoke alarms;
- (iii) Intermittent sound.

The following and similar types of sounds should be avoided:

- (iv) Melodious sounds, animal and insect sounds;
 - (v) Sounds that confuse the identification of a vehicle and/or its operation (e.g. acceleration, deceleration etc.).
- (b) The sound to be generated by the AVAS should be easily indicative of vehicle behaviour, for example, through the automatic variation of sound level or characteristics in synchronization with vehicle speed.
- (c) The sound level to be generated by the AVAS should not exceed the approximate sound level of a similar vehicle of the same category equipped with an internal combustion engine and operating under the same conditions.

Environmental consideration:

The development of the AVAS shall give consideration to the overall community noise impact.

Annex 3

Distinguishing number of contracting parties to the 1958 agreement in the approval mark

Any type approval granted by a Contracting Party to the 1958 Agreement shall contain a distinguishing number of the country that has granted the approval. The list of these numbers was included in all the UN Regulations, generally as a footnote, similar to that reproduced below. Following the adoption by WP.29 of the Revision 2 of the R.E.3, the list is being replaced by a reference to this annex. It needs to be amended any time when there is a new Contracting Party to the Agreement, even if there is no significant modification of the UN Regulation. The list below, kept regularly up to date, permits to replace its *in extenso* reproduction in UN Regulations by a simple reference.

1 for Germany, 2 for France, 3 for Italy, 4 for the Netherlands, 5 for Sweden, 6 for Belgium, 7 for Hungary, 8 for the Czech Republic, 9 for Spain, 10 for Serbia, 11 for the United Kingdom, 12 for Austria, 13 for Luxembourg, 14 for Switzerland, 15 (vacant), 16 for Norway, 17 for Finland, 18 for Denmark, 19 for Romania, 20 for Poland, 21 for Portugal, 22 for the Russian Federation, 23 for Greece, 24 for Ireland, 25 for Croatia, 26 for Slovenia, 27 for Slovakia, 28 for Belarus, 29 for Estonia, 30 (vacant), 31 for Bosnia and Herzegovina, 32 for Latvia, 33 (vacant), 34 for Bulgaria, 35 for Kazakhstan, 36 for Lithuania, 37 for Turkey, 38 (vacant), 39 for Azerbaijan, 40 for The former Yugoslav Republic of Macedonia, 41 (vacant), 42 for the European Union (Approvals are granted by its Member States using their respective ECE symbol), 43 for Japan, 44 (vacant), 45 for Australia, 46 for Ukraine, 47 for South Africa, 48 for New Zealand, 49 for Cyprus, 50 for Malta, 51 for the Republic of Korea, 52 for Malaysia, 53 for Thailand, 54 for Albania, 55 (vacant), 56 for Montenegro, 57 for San Marino, 58 for Tunisia, 60 for Georgia and 62 for Egypt. Other numbers shall be assigned to other countries in the chronological order in which they ratify or accede to the Agreement Concerning the Adoption of Uniform Technical Prescriptions for Wheeled Vehicles, Equipment and Parts which can be Fitted and/or be Used on Wheeled Vehicles and the Conditions for Reciprocal Recognition of Approvals Granted on the Basis of these Prescriptions, and the numbers thus assigned shall be communicated by the Secretary-General of the United Nations to the Contracting Parties to the Agreement.

Annex 4

Recommendation on market fuel quality

1. Purpose of the recommendation

This recommendation has been developed to inform governments about the appropriate market fuel quality that is protective of vehicle emission control technologies. The regulated vehicle emissions limits and associated market fuel qualities should be consistent with local air quality expectations.

2. Scope of the recommendation

This recommendation applies to fuel quality parameters that directly affect the performance and durability of engine as well as exhaust emission control equipment and that influence the content of exhaust emissions.

3. Exclusions

This recommendation imposes no obligation on Contracting Parties to the 1958 Agreement to accept in their territory fuels complying with the parameters outlined in this recommendation that may have been introduced by other Contracting Parties or other countries. Compliance with applicable fuel quality legislation and standards is required in respect of fuels offered for sale in Contracting Parties.

4. Abbreviations

AQIRP	Air Quality Improvement Research Programme
CEN	European Committee for Standardization
CCR	Conradson Carbon Residue (indication of fuel tendency to form carbon deposits)
CFPP	Cold Filter Plugging Point (measure for lowest temperature at which a fuel will give trouble-free flow)
FAME	Fatty Acid Methyl Esters
FBP	Final Boiling Point
DPF	Diesel Particulate Filter
HC	Hydrocarbons
JCAP	Japan Clean Air Programme
OBD	On-Board Diagnostics
MON	Motor Octane Number
PAH	Polycyclic Aromatic Hydrocarbons
PM	Particulate Matter
RON	Research Octane Number
RVP	Reid Vapour Pressure
TEL	Tetra Ethyl Lead
VLI	Vapour Lock Index

In this annex and its appendices, for simplifying the format of the tables, the UN Regulations and their series of amendments are noted in a short form as follow: the *YY* series of amendments to UN Regulation No. *XX* is noted "*RXX.YY*".

5. Introduction

It is acknowledged that market fuel quality plays a key role in the level and type of pollutant emissions from motor vehicles. Regulations and specifications for market fuel quality are not yet well harmonized (even within a given region) and they are not always fully aligned with the needs of engine technology to help meet pollutant emission regulations in force. As many world regions and cities suffer from poor air quality and move towards more stringent motor vehicle emission regulations, this requires the use of more advanced emission control technology on engines, which drives the crucial need for improved market fuel quality.

This recommendation defines a list of key fuel parameters linked to legally required emissions levels and suggests the minimum fuel quality requirements corresponding to vehicle technologies necessary to achieve and maintain such emission levels. It has to be recognised that other parameters can influence tailpipe pollutant emissions and thus adherence to this list may not be sufficient to enable durable compliance to the relevant emissions standards for all vehicle concepts.

The list of parameters has been herewith linked to emission limits set in the various series of UN Regulations Nos. 83 and 49 up to R83.05 (row B) and R49.03 (row B1) and UN Regulation No. 96 up to R96.02. An extension to cover more recent and more stringent emission limits may be needed in due time to keep this recommendation updated to technical progress.

International fuel standards (e.g. CEN) have been developed from the emission technology-fuel specifications that have been driven by European legislation. These CEN standards, developed on a technical basis between the various stakeholders in CEN, provide for European market fuels that are, essentially, fit for purpose.

The parallel application of appropriate market fuel standards must be an important part of an integrated approach by Contracting Parties to enable improved and long-lasting emission reductions during the lifetime of all motor vehicles.

6. Appendices content

Appendix 1 shows the historical development of on-road and non-road emission standards and fuel quality (based on CEN standards).

Appendix 2 details the fuel parameters aligned with the progression of the UN emission standards that require the use of more advanced exhaust after-treatment control technology that are affected by market fuel quality.

Appendix 3 shows the correlation between the series of UN Regulations Nos. 83, 49 and 96 and the parallel Euro standards.

Appendix 4 indicates a guideline document on good practice for fuel housekeeping.

7. Market fuel quality

The clearly demonstrated link between emission standards and market fuel quality – which the European Union, Japan and the United States of America have all followed - should be followed in those world areas that are now introducing for the first time or adopting more stringent emission standards, for on-road motor vehicles and Non-Road Mobile Machinery (NRMM).

7.1. Gasoline – on road vehicles

<i>Unleaded Gasoline</i>	<i>R83.03</i>	<i>R83.05 (row A)</i>	<i>R83.05 (row B)</i>	<i>Test method</i>
Lead [g/l]	No intentional addition, with a max ≤ 0.013	No intentional addition, with a max ≤ 0.005	No intentional addition, with a max ≤ 0.005	EN 237
Sulphur [mg/kg]	≤ 500	≤ 150	≤ 50 ¹	EN ISO 20846 EN ISO 20884
Metal Additives [mg/l]	----- Not permitted -----			
Oxygen [%m/m]	≤ 2.7	≤ 2.7	≤ 2.7	EN 1601 EN 13132
Oxygenates [%v/v]				
- methanol	≤ 3.0 ²	≤ 3.0 ²	≤ 3.0 ²	EN 1601 EN 13132
- ethanol	≤ 5.0	≤ 5.0	≤ 5.0	
- iso-propyl alcohol	≤ 10.0	≤ 10.0	≤ 10.0	
- iso-butyl alcohol	≤ 10.0	≤ 10.0	≤ 10.0	
- tert-butyl alcohol	≤ 7.0	≤ 7.0	≤ 7.0	
- ethers	≤ 15.0	≤ 15.0	≤ 15.0	
- other oxygenates	≤ 10.0	≤ 10.0	≤ 10.0	
RVP [kPa]	35 - 100	45 – 100	45 – 100	EN 13016/1 DVPE
Density [kg/m ³]	725 – 780	720 – 775	720 – 775	EN ISO 3675 EN ISO 12185
RON	≥ 95	≥ 95	≥ 95	EN ISO 5164
MON	≥ 85	≥ 85	≥ 85	EN ISO 5163
Benzene [%v/v]	≤ 5	≤ 1	≤ 1	EN 238 EN 14517
Aromatics [%v/v]	-	≤ 42	≤ 35	EN 14517 EN15553
Olefins [%v/v]	-	≤ 18	≤ 18	EN 14517 EN15553
VLI (10VP + E70)	-	1 050 – 1 250	1 050 – 1 250	
Residue [%v/v]	< 2	< 2	< 2	EN ISO 3405

¹ Corresponds to the United Nations Environment Programme (UNEP) decision taken at the fourth global meeting of the Partnership for Clean Fuels and Vehicles (PCFV), held on 14 and 15 December 2005 in Nairobi, Kenya.

² Industry recommends no methanol content (non-detectable).

7.2. Volatility Classes for Unleaded Gasoline

Class (*)	A	B	C/C1	D/D1	E/E1	F/F1
Vapour pressure (kPa)	45 - 60	45 - 70	50 - 80	60 - 90	65 - 95	70 - 100
E70 (%) ¹	20 - 48	20 - 48	22 - 50	22 - 50	22 - 50	22 - 50
E100 (%) ¹	46 - 71	46 - 71	46 - 71	46 - 71	46 - 71	46 - 71
E150 (% min) ¹	75	75	75	75	75	75
Final boiling point (°C max) (1)	210	210	210	210	210	210
T10 (°C, max) ¹	65	60	55	50	45	45
T50 (°C, max) ¹	77-100	77-100	75-100	70-100	65-100	65-100
T90 (°C, max) ¹	130-175	130-175	130-175	130-175	130-175	130-175
Distillation residue (% V/V)	2	2	2	2	2	2
Vapour Lock Index (VLI) (10 VP + 7 E70) (index max)	-	-	C	D	E	F
Vapour Lock Index (VLI) (10 VP + 7 E70) (index max)			C1 1 050	D1 1 150	E1 1 200	F1 1 250

* "Class" is based on the minimum expected ambient temperature of the market and will vary by season. Implementing country to choose volatility class or classes appropriate to their yearly ambient temperature conditions.

¹ E-values or T-values as alternatives.

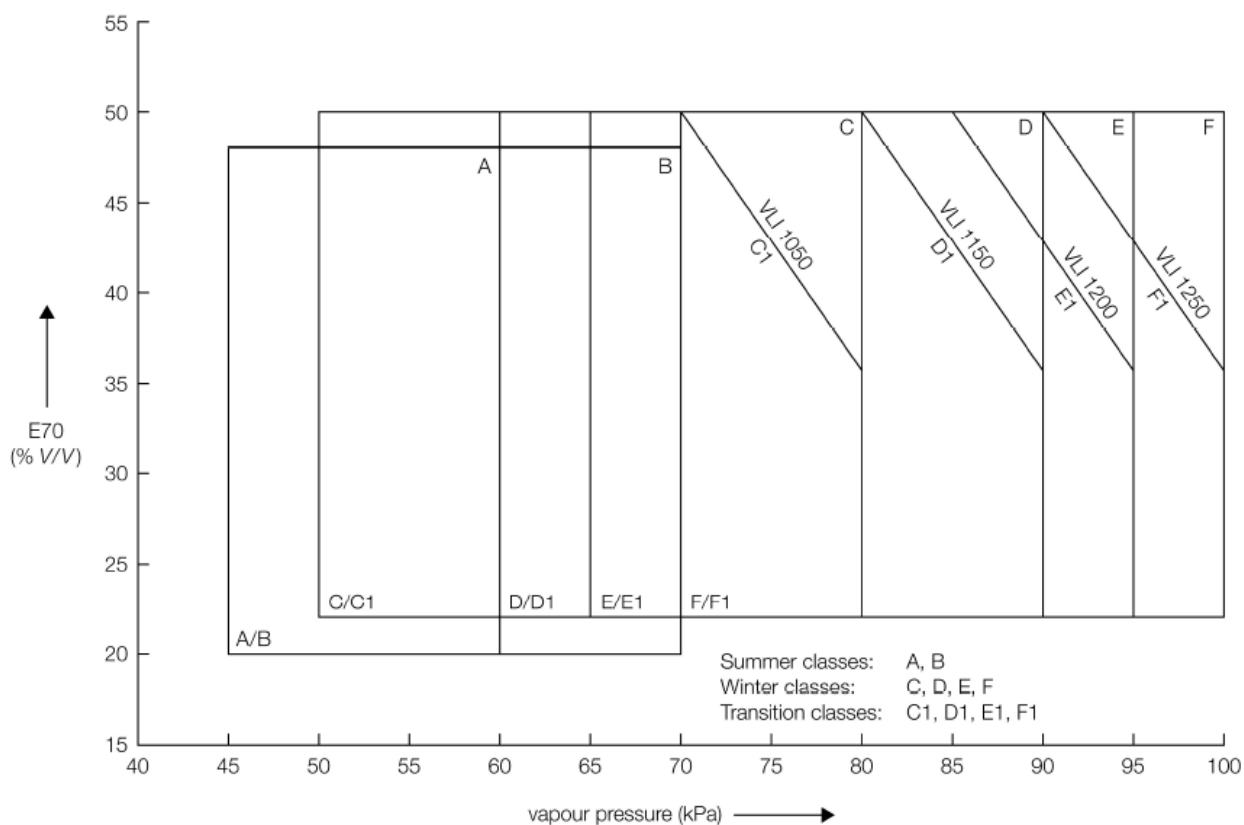

Relation between vapour pressure (VP), E70 and VLI for the ten different volatility classes for unleaded gasoline

7.3. Diesel – on-road vehicles

	<i>R83 - 03series and R49.02 (Stage II)</i>	<i>R83.05 (row A) and R49.03 (row A)</i>	<i>R83.05 (row B) and R49.03 (row B)</i>	<i>Test method</i>
Sulphur [mg/kg]	≤ 500	≤ 350	≤ 50 ¹	EN ISO 20846 EN ISO 20884
Ash [%m/m]	≤ 0.01	≤ 0.01	≤ 0.01	EN/ISO 6245
Total Contamination [mg/kg]	≤ 24	≤ 24	≤ 24	EN 12662
Cetane Number ²	≥ 49	≥ 51	≥ 51	EN ISO 5165
Cetane Index ²	≥ 46	≥ 46	≥ 46	EN ISO 4264
Density [kg/m ³] ²	820 – 860	820 – 845	820 – 845	EN ISO 3675 EN ISO 12185
Viscosity [mm ² /s] ²	2.0 - 4.5	2.0 - 4.5	2.0 – 4.5	EN ISO 3104
Flash Point [°C]	> 55	> 55	> 55	EN ISO 2719
T50 [°C]	-	T65 = 250 min	T65 = 250 min	EN ISO 3405
T85 [°C]	≤ 350	≤ 350	≤ 350	EN ISO 3405
T95 [°C]	≤ 370	≤ 360	≤ 360	EN ISO 3405
PAH [%m/m]	≤ 11	≤ 11	≤ 11	EN 12916
Carbon residue [%m/m]	≤ 0.3	≤ 0.3	≤ 0.3	EN ISO 10370
CFPP [°C] ²	-44 to +5	-44 to +5	-44 to +5	EN 116
Cloud Point [°C] (severe winter conditions) ²	-34 to -10	-34 to -10	-34 to -10	EN 23015
Copper strip corrosion (3h at 50°C) [rating]	Class 1			EN ISO 2160
Water [mg/kg]	≤ 200	≤ 200	≤ 200	EN ISO 12937
Lubricity [micron]	≤ 460	≤ 460	≤ 460	EN ISO 12156-1
Oxidation stability [hours] ³	> 20	> 20	> 20	EN15751
FAME [%v/v]	4	4	4	EN14214 ASTM D6751
Appearance	Clear and bright, no free water or particulates			D4176 visual inspection
Ethanol/Methanol [%v/v]	Non-detectable ⁵			

¹ Corresponds to the United Nations Environment Programme (UNEP) decision taken at the fourth global meeting of the Partnership for Clean Fuels and Vehicles (PCFV), held on 14 and 15 December 2005 in Nairobi, Kenya.

² Implementing country to choose value appropriate within range for arctic or severe winter conditions. More detailed arctic or severe winter specifications for these parameters to be considered.

³ Applicable for diesel containing more than 2 per cent v/v FAME.

⁴ Up to 5 per cent v/v FAME permitted if FAME complies with ASTM D6751. Up to 7 per cent v/v FAME permitted if FAME complies with EN14214. Industry recommends that vehicle owners refer to their vehicle handbook.

⁵ At or below detection limit of method used.

7.4. Diesel – NRMM

	<i>R96</i> <i>Power bands</i> <i>A to C</i>	<i>R96.01</i> <i>Power bands</i> <i>D to G</i>	<i>R96.02</i> <i>Power bands</i> <i>H to K</i>	<i>Test</i> <i>method</i>
Sulphur [mg/kg]	≤ 2 000	≤ 2 000	≤ 300 ¹	ASTM D5453
Ash [%m/m]	≤ 0.01	≤ 0.01	≤ 0.01	EN/ISO 6245
Total Contamination [mg/kg]	≤ 24	≤ 24	≤ 24	EN 12662
Cetane Number ²	≥ 45	≥ 45	≥ 52	EN ISO 5165
Density [kg/m ³] ²	835 – 845	835 – 845	833 – 837	EN ISO 3675 ASTM D4052
Viscosity [mm ² /s] ²	2.0 - 4.5	2.0 - 4.5	2.0 – 4.5	EN ISO 3104
Flash Point [°C]	> 55	> 55	> 55	EN ISO 2719
T50 [°C]	-	-	> 250	EN ISO 3405
T95 [°C]	≤ 370	≤ 370	345-350	EN ISO 3405
Final boiling point [°C]	-	-	≤ 370	EN ISO 3405
PAH [%m/m]	≤ 11	≤ 11	≤ 11	EN 12916
Carbon residue [%m/m]	≤ 0.3	≤ 0.3	≤ 0.3	EN ISO 10370
CFPP [°C] ²	-44 to +5	-44 to +5	-44 to +5	EN 116
Cloud Point [°C] (severe winter conditions) ²	-34 to -10	-34 to -10	-34 to -10	EN 23015
Copper strip corrosion (3h at 50°C) [rating]	Class 1			EN ISO 2160
Water [mg/kg]	≤ 500	≤ 500	≤ 500	EN ISO 12937
Lubricity [micron]	≤ 460	≤ 460	≤ 460	EN ISO 12156-1
Oxidation stability [hours] ³	> 20	> 20	> 20	EN15751
FAME [%v/v]	4	4	4	EN14214 ASTM D6751
Appearance	Clear and bright, no free water or particulates			D4176 visual inspection
Ethanol/Methanol [%v/v]	Non-detectable ⁵			

¹ Already agreed in annex to the Consolidated Resolution on the Construction of Vehicles (R.E.3) for on-road engines only. Industry recommends maximum 50 ppm sulphur.

² Implementing country to choose value appropriate within range for arctic or severe winter conditions. More detailed arctic or severe winter specifications for these parameters to be considered.

³ Applicable for diesel containing more than 2 per cent v/v FAME.

⁴ Up to 5 per cent v/v FAME permitted if FAME complies with ASTM D6751. Up to 7 per cent v/v FAME permitted if FAME complies with EN14214. Industry recommends that vehicle owners refer to their vehicle handbook.

⁵ At or below detection limit of method used.

Annex 4 - Appendix 1

Evolution of the UNECE emission limits

Emission standards have been linked with a revision of the respective European market fuel standards (EN228 and EN590):

On-road standards

UN Emission Levels	Gasoline				Diesel				Date of application	
	CO (g/km)	HC+NOx (HC/NOx) (g/km)		PM (g/km)	Fuel standard	CO (g/km)	HC+NOx (HC/NOx) (g/km)	PM (g/km)		Fuel standard
R83.03	2.2	0.5		-	EN228: 1993	1.0	0.7	0.08	EN590: 1993	1996
R83.05 (level A)	2.3	0.2	0.15	-	EN228: 1999	0.64	0.50	0.05	EN590: 2000	2000
R83.05 (level B)	1.0	0.1	0.08	-	EN228: 2004	0.5	0.30	0.025	EN590: 2004	2005
R83.06	1.0	0.1	0.60	0.0045	EN228: 2008	0.5	0.23	0.0045	EN590: 2008	2009

UN Emission Levels	Diesel						Date of application
	CO (g/kWh)	NMHC (g/kWh)	THC (g/kWh)	NOx (g/kWh)	PM (g/kWh)	Fuel standard	
R49.02 (level B) ¹	4.0	-	1.1	7.0	0.15	EN590: 1993	1995
R49.03 (level A) ²	5.45	0.78	1.6	5.0	0.03	EN590: 2000	2000
R49.03 (level B1) ²	4.0	0.55	1.1	3.5	0.03	EN590: 2004	2005
R49.03 (level B2) ²	4.0	0.55	1.1	2.0	0.02	EN590: 2008	2008

¹ Limits shown for the 13-mode test.

² Limits shown for the ETC test only.

Non-road standards

UN Emission Levels	Power band	Net power (P) (kW)	CO (g/kWh)	HC (g/kWh)	NOx (g/kWh)	PM (g/kWh)	Date of application
R96	A	$P \geq 130$	5	1.3	9.2	0.54	1995
	B	$75 \leq P < 130$	5	1.3	9.2	0.7	
	C	$37 \leq P < 75$	6.5	1.3	9.2	0.85	
R96.01	E	$130 \leq P \leq 560$	3.5	1.0	6.0	0.2	2001
	F	$75 \leq P < 130$	5.0	1.0	6.0	0.3	
	G	$37 \leq P < 75$	5.0	1.3	7.0	0.4	
	D	$18 \leq P < 37$	5.5	1.5	8.0	0.8	

UN Emission Levels	Power band	Net power (P) (kW)	CO (g/kWh)	HC + NOx (g/kWh)	PM (g/kWh)	Date of application
R96.02	H	$130 \leq P \leq 560$	3.5	4.0	0.2	2008
	I	$75 \leq P < 130$	5.0	4.0	0.3	
	J	$37 \leq P < 75$	5.0	4.7	0.4	
	K	$19 \leq P < 37$	5.5	7.5	0.6	

Annex 4 - Appendix 2

Evolution of stringency of gasoline market fuel quality standards

On-road vehicles

Gasoline	<i>R83.03</i>	<i>R83.05 (row A)</i>	<i>R83.05 (row B)</i>
RON	95	95	95
MON	85	85	85
Lead	0.013	0.005	0.005
Sulphur	500	150	50 / 10 ¹
Benzene	5	1	1
Aromatics	-	42	35
Olefins	-	21	18
Oxygen	-	2.7	2.7
RVP	35 - 100	45 - 100	45 - 100
VLI	-	1 050 – 1 250	1 050 – 1 250
Density	725 - 780	720 - 775	720 - 775
FBP	215	210	210
E70	15 - 47	20 - 50	20 - 50
E100	40 - 70	46 - 71	46 - 71
E180	85	-	-
Residue	2	2	2

¹ For the EU, maximum 10 ppm sulphur content is mandatory since 1 January 2009.

On-road vehicles

<i>Diesel</i>	<i>R83.03 R49.03</i>	<i>R83.05 (level A) R49.05 (level A)</i>	<i>R83.05 (level B) R49.05 (level B1)</i>
Cetane Number	49	51	51
Cetane Index	46	46	46
Sulphur	500	350	50 / 10 ²
Density	820 - 860	820 - 845	820 - 845
Viscosity	2.0 – 4.5	2.0 – 4.5	2.0 – 4.5
T50	Report	T65 = 250 min	T65 = 250 min
T85	350 max	350 max	350 max
T95	360 max	360 max	360 max
PAH	11	11	11
Flash Point	55	55	55
CCR	0.3	0.3	0.3
CFPP	-44 to +5	-44 to +5	-44 to +5
Cloud Point	-34 to -10	-34 to -10	-34 to -10
Water and sediment	-	0.0024	0.0024
Water	0.02	0.02	0.02
Ash	0.01	0.01	0.01
Lubricity	-	460	460

² For the EU, maximum 10 ppm sulphur content is mandatory since 1 January 2009.

Annex 4 - Appendix 3

Correlation between UN Regulations and Euro standards*

On-road vehicles

Correlation between the series of amendments of Regulations Nos. 83 and 49 and Euro emission standards

<i>UN Regulation No. 49</i>	<i>Euro standard</i>
R49.02 level B	Euro II
R49.03 level A	Euro III
R49.03 level B1	Euro IV

<i>UN Regulation No. 83</i>	<i>Euro standard</i>
R83.03	Euro 2
R83.05 level A	Euro 3
R83.05 level B	Euro 4
----	Euro5
	Euro 6

Non-road vehicles

Correlation between the series of amendments to Regulation No. 96 and Euro emission standards

<i>UN Regulation No. 96</i>	<i>NRMM Directive 97/68/EC</i>
R96	Stage I
R96.01	Stage II
R96.02	Stage IIIA

* *Note by the secretariat:* The recommendation of fuel quality is only applicable to the listed emission levels; high emission standards may require more stringent fuel requirements.

Annex 4 - Appendix 4

Housekeeping

Some problems encountered by vehicles linked to fuel quality can be caused by adulteration of the fuel in the fuel distribution system, after the fuel has left the refinery gate. Failure to invest in adequate pipeline as well as storage facilities and failure to maintain the equipment can lead to volatility losses, fuel leakage, and contamination by particulates and water. These, in turn, can lead to many of the vehicle problems mentioned previously. Poor maintenance practices at the service station, such as too infrequent replacement of fuel dispenser filters or "dipping" of tanks to check for water, can magnify these problems, including corrosion problems within vehicles. CEN has issued a useful guideline document on good practice for fuel housekeeping: CEN TR/15367.¹

¹ See Annex C for the correlation between the series of amendments to UN Regulations Nos. 83, 49 and 96 and the respective European emission standards.

Annex 5

Design principles for Control Systems of Advanced Driver Assistance System (ADAS)

This document was revised with reference to the discussion results of the last ITS Informal Group Meeting, held on 15th, March, 2013. As a next step, in accordance with the programme of work, it will be forwarded to WP29 to deliberate its treatment.

Contents

1.	Preface	99
2.	Scope	99
3.	Existing regulations	100
4.	Control principles.....	100
4.1	Control elements.....	101
4.2	Operational elements	101
4.3	Display elements.....	101
4.4	Supplementary elements	102
5.	Summary.....	103
	Appendix: Human-Machine Interaction (HMI) - Considerations for Control Systems of ADAS	104
1.	Introduction	104
2.	Human factors in driving automation	106
3.	Driver in-the-loop	107
4.	Future works	108
5.	References	109

1. Preface

ADAS (Advanced Driver Assistance Systems) have been developed to support drivers and enhance road safety. Among the products on the market are warning systems to advise of a safety hazard; control systems to improve the ease of control during normal driving and help avoid accidents and/or mitigate the crash severity in critical situations. In June 2011, the WP.29/ITS Informal Group developed and proposed basic guidelines for imminent warning systems, part of which was already referred to in the regulatory discussion of AEBS (Advanced Emergency Braking Systems) and LDWS (Lane Departure Warning Systems).

Studies on control systems are under way in various countries and regions, but they have not yet resulted in internationally uniform guidelines. However, control systems require a certain basic understanding for development, because it is imperative that the average driver is able to safely and comfortably operate these systems according to his/ her intentions and take full control as needed. To address this concern, Europe has conducted studies under the RESPONSE 3 project and Japan similar studies under the ASV project.

This document focuses on control systems among ADAS and summarizes the minimum necessary principles that are of vital importance for HMI (Human-Machine Interaction) in the use of control systems. Considering that newly developed control systems are still on the way and that a variety of systems will be marketed in the future, this document focuses on general principles that are applicable across the board and not those applicable only to specific systems.

In the main text of this document, we first describe the principles that are important for HMI in the use of ADAS. For control systems, there are twelve principles in total. Next, in the form of an annex, we summarize some issues in automation, important viewpoints and future tasks for HMI based on findings and experience. Reference is made to the influence of further automation of these systems that is expected as control systems evolve.

This document was drafted by the IHRA (International Harmonized Research Activities)-ITS working group, revised several times, and then submitted to the ITS Informal Group. The next step is left to the discretion of the ITS Informal Group. It should be noted that this document is not aimed at regulation but was written as a reference for the stakeholders who are engaged in the design and development of human-centered ADAS.

2. Scope

ADAS can be classified into three categories: information provision, warning, and control. Guidelines for limiting driver distraction from in-vehicle information systems have already been established and are used on a self-commitment basis. Regarding warnings, the ITS Informal Group submitted the "Guidelines on establishing requirements for high-priority warning signals", which was adopted at the 154th session of WP.29 in June 2011.

This document discusses control systems that support and assist the driver's driving operations. Systems covered include those that involve a certain interaction (transfer of control) between the driver and the system, but exclude those that control the driving operations independently. Therefore, this document does not discuss existing ABS (Anti-lock Braking Systems) and ESC (Electronic Stability Control), nor does it cover information provision systems such as navigation devices.

In this document, we discuss systems that are used during normal driving, such as ACC (Advanced Cruise Control system) and LKS (Lane Keeping-assistance System), as well as systems used in critical situations, such as AEBS (Advanced Emergency Braking Systems), to avoid accidents and mitigate crash severity. AEBS are currently being regulated, but we include them in our discussion because they involve the transfer of control between the driver and the system.

The present principles are applicable mainly to passenger cars (M₁), but the basic philosophy is applicable to other categories of vehicles. Therefore, it is desirable that they are also applied to vehicle categories such as M₂, M₃, N₁, N₂, and N₃. The principles are expected to apply to both original equipment and aftermarket devices. It should be noted, however, that there may be some difficulties coordinating aftermarket devices with the control systems fitted by vehicle manufacturers.

3. Existing Regulations

There are existing Regulations which are most relevant to the principles in this document.

/ UN Regulation No. 121	Vehicles with regard to the location and identification of hand controls, tell-tales and indicators
/ FMVSS No. 101	Controls and displays.
/ UN Regulation No. 130	Lane Departure Warning System (LDWS)
/ UN Regulation No. 131	Advanced Emergency Braking Systems (AEBS)

4. Control principles

The principles are divided into four sections:

- Control elements;
- Operational elements;
- Display elements; and
- Supplementary elements.

A total of twelve principles are established. Each principle defines the main Recommendations to be fulfilled for the HMI to allow the driver to easily and accurately understand and judge driving situations and effectively use the control system according to their intentions.

The section on control elements and operational elements is divided into those for normal situations and those for critical situations, and an explanation is given on how the control system should be operated. In the section on display elements, the discussion covers the notification of normal functionality, failure, reduction in the scope of functionality, and the transfer of control. The section on supplementary elements includes a warning against over-reliance on sensors and systems, which is potentially dangerous, and discusses the use of standard symbols and information for road users.

In this document, normal driving refers to situations that do not require immediate responses from the driver and/or vehicle to avoid a collision. Critical driving refers to situations that do require immediate responses from the driver and/or vehicle to avoid or mitigate a collision.

4.1 Control elements

- (a) System actions should be easy to override at any time under normal driving situations and when collisions are avoidable.

Explanation: One of the main objectives of ADAS such as ACC, etc., used in normal driving situations, is to reduce the driving workload. During normal driving, the system should be capable of being overridden by the driver using simple, deliberate action(s) at any point in time.

- (b) When a collision is determined to be imminent, the system can take actions intended to avoid and/or mitigate the crash severity.

Explanation: In critical driving situations where the driver has not taken proper avoidance actions because of impairment, distraction, inattention, or other unforeseen incidents, it should be possible to apply system intervention to try to avoid the collision or mitigate the crash severity.

4.2 Operational elements

- (a) For systems that control the vehicle under normal driving situations, the driver should have a means to transition from ON to OFF manually and to keep the system in the OFF state.

Explanation: For ease of use and/or convenience in driving, the driver's intentions should be ensured as a priority, so that the driver can switch the state of control from system to driver that is from ON to OFF and the OFF state should be kept under the driver's operation.

- (b) For systems that control the vehicle under critical driving situations, the initial set state of the system should be ON.

Explanation: For collision avoidance and/or mitigation, the first priority is to reduce trauma, therefore the system status ON should be maintained during driving. However, accounting for driver preferences, the system can be equipped with a manual OFF switch. In this case the system status should be recognizable to the driver

4.3 Display elements

- (a) Drivers should be provided with clear feedback informing them when the system is actively controlling the vehicle's speed and/ or path.

Explanation: When the system is actively controlling the vehicle, the driver should be provided with clear feedback on its activation. The driver has to be made aware of system activation so as to properly manage driving a car with assistance systems.

- (b) Drivers should be informed of the system status when system operation is malfunctioning or when there is a failure.

Explanation: When the system is malfunctioning or has failed, the driver should be informed of the system status. This is needed to avoid any misunderstanding by the driver that the system is still working.

- (c) The driver should be informed when the system detects that conditions are such that normal performance cannot be assured.

Explanation: When the system is not fully functioning, for example, the sensor performance is impaired under certain driving conditions such as rain or when road markings are not visible, the driver should be informed of the status to allow a smooth transfer of control to the driver.

- (d) Drivers should be notified of any system-initiated transfer of control between the driver and vehicle.

Explanation: Transfer of control between the driver and the vehicle would be the point when automation is realized. Any transfer of control should be transparent to the driver, but at the very least, the driver should be notified of any transfer initiated by the system so the driver is always aware if they have control of the vehicle.

4.4 Supplementary elements

- (a) In cases where systems automatically control the longitudinal and lateral behaviour of the vehicle and the driver's task is to monitor system operations, appropriate arrangements should be considered to prompt the driver to maintain their attention to the vehicle, road and traffic situation.

Explanation: When the driver is using highly automated systems such as ACC with LKS, which is the automation of longitudinal and lateral control, the driving tasks are reduced and the driver simply monitors the systems and surroundings. In these situations, it is important to ensure the driver's attention to the driving task is maintained. To ensure that the driver stays aware of the driving situation, appropriate measures should be considered to keep the driver in-the-loop.

- (b) Drivers should be notified of the proper use of the system prior to general use.

Explanation: The manufacturer should provide information on correct system use to avoid any misunderstanding and/or over-dependence on the system. For example, it is required that the driver understand what assistance systems are installed in the vehicle, and that instructions be provided on the physical limitations of the system functions prior to its use.

- (c) If symbols are used to notify the driver, a standard symbol should be used if available.

Explanation: Taking into account the use of different and/or unfamiliar vehicles, commonality of information should be secured, therefore standard symbols should be used, if available. UN Regulation No.121 could be the one that might be referred.

- (d) System actions requiring the attention of other road users should be signaled to other road users.

Explanation: To help surrounding road users, such as other drivers, pedestrians, and cyclists, be aware of vehicle actions, the system's actions should be signaled when braking, changing lanes or for hazards. In consideration of the system functions and driving situation, the need for display might be determined on a case-by-case basis.

5. Summary

ADAS control systems are still being developed and various new systems will emerge in the future. For the development of technologies, it is important to continuously improve the safety and user-friendliness of these systems for the average driver. If a negative effect is felt, these systems may lose credibility among the general public and subsequent development may be hindered. To prevent such an event and to encourage proper development of the systems, it is important to define the principles to be followed as a basic guideline.

These principles are limited to the main Recommendations considered to be of critical importance. However, systems that arrive on the market in the future may require guidance for aspects that are not covered. Changes over time may also make some of the principles obsolete or unnecessary. The present principles shall therefore be revised as appropriate, and this task should be assigned to the ITS Informal Group (in some cases in consultation with the respective GR group that may govern a specific system in question), since the present principles deal with ADAS in general and not with specific systems.

As a future process, the UNECE WP.29 ITS Informal Group and other relevant working groups in the UNECE WP.29 will engage in comprehensive discussions on a mechanism that will ensure effective implementation of the control system principles. This annex was adopted by WP.29 at its 160th session (ECE/TRANS/WP.29/1104, para.22) and transmitted to the Working Party on Road Safety (WP.1) as a reference.

Annex 5 – Appendix

Human-Machine Interaction (HMI) - Considerations for control systems of ADAS

This document describes some of the human factors issues associated with driving task automation.

1. Introduction

Automated control systems are becoming more common in new road vehicles. In general, automation is designed to assist with mechanical or electrical accomplishment of tasks (Wickens & Hollands, 2000). It involves actively selecting and transforming information, making decisions, and/or controlling processes (Lee & See, 2004). Automated vehicle control systems are intended to improve safety (crash avoidance and mitigation), comfort (decrease of driver's workload; improved driving comfort), traffic efficiency (road capacity usage; reduced congestion), and the environment (decreased traffic noise; reduced fuel consumption).

The automation of basic control functions (e.g., automatic transmission, anti-lock brakes and electronic stability control) has proven very effective, but the safety implications of more advanced systems may be unclear in some cases. It is controversial that system safety will always be enhanced by allocating functions to automatic devices rather than to the drivers. A potential concern may be the out-of-loop performance problems that have been widely documented as a potential negative consequence of automation (e.g., Weiner & Curry, 1980).

Advanced Driver Assistance Systems (ADAS) use sensors and complex signal processing to detect and evaluate the vehicle environment; this includes the collection and evaluation of infrastructure-based data, if available. They provide active support for lateral or longitudinal control, information and warnings (RESPONSE, 2001). Tasks carried out by ADAS range from information to collision avoidance and vehicle control. In ADAS, warning and control each have an important role to play for safety enhancement, and these systems can be categorized based on the levels of assistance that they provide to drivers (See Figure 1, adapted from Flemisch et al., 2008).

Figure 1
Role Spectrum in Vehicle Automation (Flemisch et al., 2008).

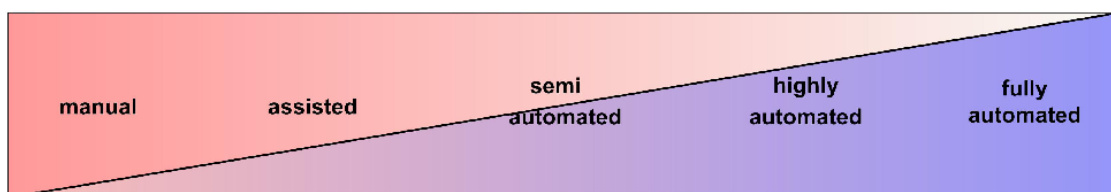

Figure 1 illustrates the progression of assistance and the associated roles of the driver (Flemisch et al., 2008). The manual driver means that the driver manually controls the vehicle without any assistance systems. The assisted driver implies that the driver is supported mainly by warning systems such as forward collision warning and lane departure warning. In semi-automated, about half of the driving tasks are automated illustrating ACC in which the driver executes main control over the lateral vehicle guidance whereas the automation executes control over the longitudinal guidance. In highly-automated, the automation executes control of essential parts of the driving task, such as integrated lateral and longitudinal control and the driver mainly monitors the automation, takes over when necessary, hand-on or hand-off driving can be both classified as highly automated.

Figure 2 illustrates how ADAS assist drivers in the tasks of detection, judgment, and operation (Hiramatsu, 2005). When no ADAS are present during conventional driving, drivers monitor the feedback of the vehicle behavior. They detect and recognize elements in the driving environment, make judgments about imminent risks, if these occur, and about the future effects of any actions they take; and take control of the vehicle and carry out the consequent maneuver to mitigate the risk (Ho, 2006).

At Level 1, ADAS provides the least assistance (see Figure 2). These ADAS present information acquired from sensors to the driver, and assist them only with the detection of relevant information. They enhance the perception of drivers by aiding their awareness of the driving environment, but do not provide warning alerts. An example of such ADAS is a Route Guidance System that helps the driver to look for the route to destination. Another example of Level 1 is rear vision camera that shows the area behind the vehicle and provides information. – if it provides an alert then it is a Level 2 system.

Level 2 ADAS offers aid to drivers by assisting their assessment of the criticality of hazards through warnings to help drivers avoid critical situations. This works with detection of the driving environment that's also provided by Level 1 ADAS. Examples of Level 2 ADAS are the Forward Collision Warning (FCW) system and the Lane Departure Warning (LDW) system.

At Level 3, ADAS provides more assistance to the driver through vehicle control, and avoids or mitigates hazards actively, without direct input from the driver. These intervening assistance systems have a higher level of automation and a lower level of driver control. An example of Level 3 ADAS is the Adaptive Cruise Control (ACC) + the Advanced Emergency Braking System (AEBS), which detects obstacles in front of the driver and intervenes on its own by using avoidance and/or mitigation measures, such as applying the moderate and/or rapid brakes to adjust the speed in order for the headway not to exceed a certain threshold. As a consequence, Level 3 ADAS has two features; one is for systems used in the normal driving situation such as ACC, and the other in critical driving situations such as AEBS.

Figure 2
Behavioural model of a driver and level of driver assistance

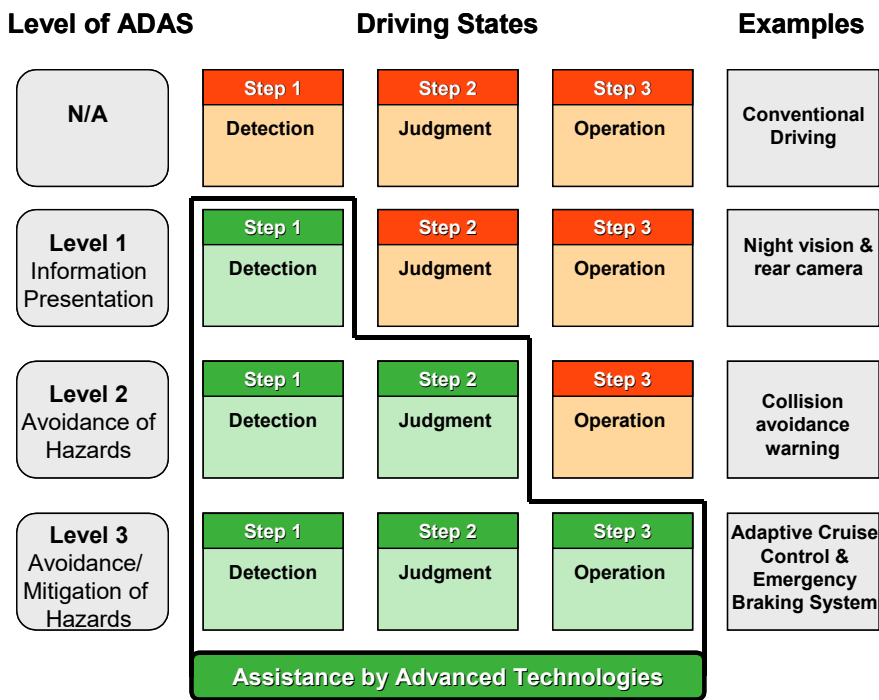

2. Human factors in driving automation

The introduction of automation in vehicles poses a host of human factors concerns (e.g., Sheridan, 1992). Advanced automation can fundamentally change the driving task and the role of the driver in the road-traffic environment. In addition to facilitating driver performance, the introduction of automation in cars also has the potential for deteriorating performance (Young & Stanton, 1997). The following sections summarize the main issues relating to the automation of the driving task.

2.1 Workload

Driver Mental Workload is a central concern for automation. It has been suggested that automation has dual effects on mental workload (Stanton, Young & Walker, 2007). Automation could decrease driver workload in some situations, if it takes over driving activities; or it can increase attentional demand and mental workload in other areas, such as trying to keep track of what the automation is doing. In the former situation, fewer driving tasks may result in driver *underload* through reduced attentional demand. The latter case could lead to driver *overload*, which can occur under conditions of system failure or when a driver is unfamiliar with the system (Brook-Carter & Parkes, 2000). Both overload and underload can be detrimental to performance (Stanton et al., 2007).

Automation is usually intended to lighten workload, but when a given level of automation lowers drivers' mental workload to the point of underload, there is the possibility that should a device fail, the driver is faced with an explosion of demand to circumvent an accident. In certain cases drivers cannot cope with this occurrence, which could cause a crash (Young & Stanton, 1997). ADAS may take over a large proportion of the workload, which would lead drivers to overestimate system performance and, as a result, to drive more passively. A more complacent or passive attitude can lead to further problems such as monotony and fatigue (Thiffault & Bergeron, 2003).

Situation awareness and response time may be affected by automation because it takes operators "out-of-the-loop". Drivers tend to use less effort with automation, and a psycho-physiological consequence of less activity is reduced alertness. Alternatively, alert drivers may take advantage of this reduction in task demand to do something else (e.g., multitask). It has been suggested that the basic goal should be to optimize – not reduce – workload, which would entail a balancing of demands and resources of both task and operator (Young & Stanton, 1997; Reichart, 1993; Rumar, 1993).

2.2 Trust

Trust in automation, to a large degree, guides reliance on automation. Lee and See (2004) have argued, "People tend to rely on automation they trust and tend to reject automation they do not" (p. 51). Too little trust may result in technology being ignored, negating its benefits; and too much trust may result in the operator becoming too dependent on the automated system (Parasuraman & Riley, 1997). In other words, drivers may undertrust and therefore underutilize automated assistance systems; or they may overtrust and consequently overly rely on the systems. Generally, trust appears to be largely regulated by the driver's perception of the system's capability. Specifically, if the system is being perceived as being more capable to carry out the task than the driver, then it will be trusted and relied on, and vice versa (Young, 2008).

Also, trust is generally considered to be a history-dependent attitude that evolves over time (Lee & See, 2004). In addition, this evolution of trust will differ between systems that operate in normal and critical driving situations. In the normal driving condition, trust may lead to heavy reliance if the driver perceives the system as being reliable over time. In

critical driving situations, drivers may not have the opportunity to experience the system and develop the high level of confidence needed to trust systems that automatically perform safety-critical actions.

Rudin-Brown and Parker (2004) tested drivers' levels of trust with the ACC before and after use and found that the degree of trust in ACC increased significantly following exposure to the system. Creating trustworthy automated systems is therefore important. Appropriate trust and reliance are based on how well the capacities of vehicle automation are conveyed to the driver, and thus driver awareness and training are essential (Lee & See, 2004).

2.3 Adaptation

Behavioural Adaptation as with any changes in the driving environment, the introduction of ADAS may lead to changes in driver behaviour. Behaviour changes caused by the introduction of ADAS are a major challenge for the efficiency and safety of these systems. Behavioural adaptation is "an unintended behaviour that occurs following the introduction of changes to the road transport system" (Brook-Carter & Parkes, 2000; OECD, 1990). These negative adaptations may reduce some of the planned safety results of ADAS. For example, ADAS may take over a large proportion of the workload, which would lead drivers to overestimate system performance and, as a result, to drive more passively.

3. Driver-in-the-loop

The notion of *driver-in-the-loop* means that a driver is involved in the driving task and is aware of the vehicle status and road traffic situation. Being *in-the-loop* means that the driver plays an active role in the driver-vehicle system (see Figures 1 and 2). They actively monitor information, detect emerging situations, make decisions and respond as needed. By contrast, *out-of-loop* performance means that the driver is not immediately aware of the vehicle and the road traffic situation because they are not actively monitoring, making

decisions or providing input to the driving task (Kienle et al., 2009). Being out-of-loop leads to a diminished ability to detect system errors and manually respond to them (Endsley & Kiris, 1995).

The Vienna Convention for Road Traffic, a treaty founded in 1968, was designed to increase road safety by standardizing the uniform traffic rules at an international level. Several articles in the Vienna Convention are relevant to the discussion of automation and control in vehicles. Specifically Articles 8 & 13 require that drivers be in control of their vehicle at all times. This may not always be the case with some autonomous driving functions. The issue of consistency between the Vienna Convention and the vehicle technical regulations developed by WP.29 and WP.1 (Working Party on Road Traffic Safety) is currently being discussed.¹ Some countries, such as the United States and Canada, did not sign the treaty.

It will be difficult to make a line between in the loop and out of the loop. For example, the task of monitoring the systems and surroundings could be out of the loop if the driver's attention shifts away from the situation, but it could be in the loop if he/she carefully monitors them. This means that the line between them could change according to how much the driver is aware of the driving situation.

Automation may be relevant to likelihood for causation of out of the loop. A circumstance where ADAS may remove the driver from the loop would be a lane keeping assistance system coupled with ACC. If drivers only periodically monitor the vehicle instead of being in control, they could become out of the loop. Failure to notice a hazard may result in confusion due to a lack of understanding of the warning system's response to the hazard. Generally, when out of the control loop, humans are poor at monitoring tasks (Bainbridge, 1987).

Research findings on the effect of in-vehicle automation on situation awareness are mixed. For example, Stanton and Young (2005) found that situation awareness was reduced by the use of ACC. Similarly, Rudin-Brown et al. (2004) found that drivers tend to direct their attention away from the driving task and toward a secondary task (e.g., using an in-vehicle telematics device) while using ACC. However, Ma and Kaber (2005) found that in-vehicle automated systems generally facilitate driver situation awareness. They reported that the use of an ACC system improved driving task situation awareness under typical driving conditions and lowered driver mental workload.

Keeping the driver-in-the-loop is also particularly relevant to the occurrence of traffic incidents, where good situation awareness is crucial for drivers to be able to effectively cope with the situation. As such, a major research objective in ADAS research is to determine what techniques are optimal for keeping the driver-in-the-loop during automated control. A premise based on the above-mentioned human factors in vehicle automation is that driver involvement in car driving, under typical driving conditions, would be maintained at an optimal level if:

- (a) Mental workload would be at a moderate level
- (b) There would be good situation awareness throughout the drive
- (c) Drivers would have appropriate trust in the automated system(s), and
- (d) Negative behavioural adaptation (compensating behaviours) would not occur.

¹ *Note by the secretariat:* Articles 8 & 13 of the 1968 Vienna Convention on Road Traffic have been amended with effect on 23 March 2016 to overcome this limitation (ECE/TRANS/WP.1/145).

Automated in-vehicle systems developed and designed with control principles in mind would support and enhance the task of driving a car. Furthermore, ensuring that, during ADAS development, drivers stay informed and in control can avoid (or reduce) errors due to out-of-the-loop control problems.

4. Future work

Automation will bring the car driving more convenient and safe, however it will also cite some concern that automation could lead the driver to be less aware of the driving situation and increase risk. For the proper development of automation in vehicles, it will be needed to promote further research works on the points as follows:

- (a) To develop how to measure situation awareness in the context of driving, understand how it varies, estimates its preferred level and how that can be maintained.
- (b) To clarify what is underload or overload and how to measure it, and how to avoid over-dependency in accordance with the change of driver behavior as a result of adaptation.
- (c) To explore how to retain the responsibility in car driving when the automation level highly increases.

5. References

- Bainbridge, L. (1987). Ironies of Automation. In J. Rasmussen, K. Duncan, and J. Leplat (Eds.), *New Technology and Human Error*. Chichester and New York: John Wiley & Sons.
- Brook-Carter, N. & Parkes, A. (2000). *ADAS and Driver Behavioural Adaptation*. European Community: Competitive and Sustainable Growth Programme.
- Endsley, M.R. & Kiris, E.O. (1995). The out-of-the-loop performance problem and level of control in automation. *Human Factors*, 37(2), 381-94.
- Flemisch, F., Kelsch, J., Löper, C., Schieben, A., & Schindler, J. (2008). Automation spectrum, inner / outer compatibility and other potentially useful human factors concepts for assistance and automation. In D. de Waard, F.O. Flemisch, B. Lorenz, H. Oberheid, and K.A. Brookhuis (Eds.) (2008), *Human Factors for assistance and automation* (pp. 1 - 16). Maastricht, the Netherlands: Shaker Publishing.
- Hiramatsu, K. (2005). International Harmonized Research Activities – Intelligent Transport Systems (IHRA – ITS) Working Group Report. In *19th International Technical Conference on the Enhanced Safety of Vehicles (ESV)*. Washington, D.C.
- Ho, A.W.L. (2006). *Integrating automobile multiple intelligent warning systems: Performance and policy implications*. M.Sc. Thesis, MIT Press, MA.
- Kienle, M., Damböck, D., Kelsch, J., Flemisch, F. & Bengler, K. (2009). Towards an H-Mode for highly automated vehicles: driving with side sticks. Proceedings of the First *International Conference on Automotive User Interfaces and Interactive Vehicular Applications* (Automotive UI 2009), Sep 21-22 2009, Essen, Germany, p. 19-23.
- Lee, J.D., & See, K.A. (2004). Trust in automation: designing for appropriate reliance. *Human Factors*, 46(1), 50-80.
- Ma, R., & Kaber, D. B. (2005). Situation awareness and workload in driving while using adaptive cruise control and a cell phone. *International Journal of Industrial Ergonomics*, 35(10), 939-953.
- O.E.C.D. (1990). *Behavioural Adaptations to Changes in the Road Transport System*. OECD, Paris.
- Parasuraman, R., & Riley, V. (1997). Human and automation: Use, misuse, disuse, abuse. *Human Factors*, 39, 230-253.
- Reichart, G. (1993). Problems in vehicle systems. In A.M. Parkes & S. Franzen (Eds.), *Driving future vehicles* (pp. 143-146). London: Taylor & Francis.
- RESPONSE (2001). The integrated Approach of User, System and Legal Perspective: Final Report on Recommendations for Testing and Market Introduction. *Project TR4022, Deliverable no. 2.2*, September 2001.
- RESPONSE 3 (2009). *Code of Practice for the Design and Evaluation of ADAS, Version 5*, (PREVENT) Preventive and Active Safety Applications Integrated Project, EU IST contract number FP6-507075.
- Rudin-Brown, C.M. & Parker, H.A. (2004). Behavioral adaptation to adaptive cruise control: implications for preventive strategies. *Transportation Research, F*, 7, 59-76.

- Rumar, K. (1993). Road User Needs. In A.M. Parkes & S. Franzen (Eds.), *Driving future vehicles* (pp. 41-48). London: Taylor & Francis.
- Sheridan, T. B. (1992). *Telerobotics, Automation, and Human Supervisory Control*. The MIT Press,
- Stanton, N.A., & Young, M.S. (2005). Driver behaviour with adaptive cruise control. *Ergonomics*, 48(10), 1294–1313.
- Stanton, N. A., Young, M. S., & Walker, G H. (2007). The psychology of driving automation: a discussion with Professor Don Norman. *International Journal of Vehicle Design*, 45(3), 289-306.
- Thiffault, P. & Bergeron, J. (2003). Monotony of road environment and driver fatigue: a simulator study, *Accident Analysis & Prevention*, 35, pp. 381-391.
- UNECE WP.29 (2010). Guidelines on establishing requirements for high-priority warning signals, Informal Document No. WP.29-150-22. Vienna Convention. (1968). *Convention on Road Traffic*. E/CONF.56/16/Rev.1/Amnd.1.
- Weiner, E. L., & Curry, R. E. (1980). Flight-deck automation: Promises and Problems. *Ergonomics*, 23, 995-1011.
- Wickens, C.D., & Hollands, J.G. (2000). *Engineering Psychology and Human Performance* (3rd Ed). Upper Saddle River, NJ: Prentice-Hall Inc.
- Young, M.S. (2008). *Driver-centred Design*. Retrieved August 30, 2009 from http://www.autofocusasia.com/automotive_design_testing.
- Young, M.S, & Stanton, N.A. (1997). Automotive automation: Investigating the impact on drivers' mental workload. *International Journal of Cognitive Ergonomics*, 1(4), 325-336.

Annex 6

Guideline on cybersecurity and data protection

Guideline on measures ensuring cybersecurity and data protection of connected vehicles and vehicles with Automated Driving Technologies

1. Preamble

- 1.1. The digitalisation of mobility and the associated increase in the amount of data are creating new requirements to be met by vehicle safety and infrastructure and the protection of the rights and freedoms of data subjects.
- 1.2. As the automation and interconnectivity of driving functions increases, the issues of data encryption and cybersecurity will become more important.
- 1.3. Connected vehicles and vehicles with Automated Driving Technologies (ADT) thus require clear cybersecurity and data protection rules. It has to be ensured that vehicles are protected from external interference and manipulation.
- 1.4. This guideline is intended to present requirements to automotive manufacturers, component/system suppliers and service providers for systems to be installed in vehicles to provide a high level of cybersecurity and to ensure data protection. They can use alternative approaches where at least an equivalent level of security can be demonstrated.
- 1.5. This guideline is intended as interim guidance until the completion of ongoing research and collaboration activities and the development of more detailed globally harmonized requirements on cybersecurity and data protection.
- 1.6. This guideline shall serve as a basis for the development of prescriptions in UN Regulations to ensure cybersecurity and data protection.
- 1.7. This guideline does not affect existing data protection legislation. This guideline is not aimed at falling short of or going beyond legal data protection regulations.

2. Scope

- 2.1. This guideline addresses the measures for connected vehicles and vehicles with ADT with regard to cybersecurity and data protection.

3. Definitions

- 3.1. (reserved)
- 3.2. "*Connected vehicle*" means a vehicle with a device installed designed to allow a wireless connection or communication possibly relating to automated driving technologies with external devices, cars, networks or services.

- 3.3. "*Cybersecurity*" means preservation of confidentiality, integrity and availability of information in the "cyberspace", i.e. the complex environment resulting from the interaction of people, software and services (e.g. on the Internet) by means of technology devices and networks connected to it, which does not exist in any physical form.
- 3.4. "*Data protection*" means a natural person's right to respect for his or her private and family life, home and communications with regard to the processing of personal data.
- 3.5. "*Data subject*" means an individual who is the subject of personal data (e.g. vehicle owners or drivers).
- 3.6. "*Data protection by default*" means a controller's obligation to implement technical and organizational measures which ensure that, by default, only personal data which are necessary for each specific purpose of the processing are processed.
- 3.7. "*Data protection by design*" means a controller's obligation to implement technical and organizational measures appropriate to the controller's processing activity which are designed to implement data protection principles with the aim of protecting the rights of data subjects by reducing the likelihood and severity of the risk to his or her private and family life, home and communications.

4. The guideline's requirements

Connected vehicles and vehicles with ADT are intended to be fitted with measures ensuring cybersecurity and data protection and shall fulfil the requirements set forth below.

- 4.1. General:
- (a) Everyone's right to his or her privacy and communications has to be respected.
 - (b) Personal data must be processed lawfully, fairly and in a transparent manner in relation to the data subject.
 - (c) Automotive manufacturer, component/system supplier and service providers shall respect the principles of data protection by default and data protection by design (see definitions 3.6 and 3.7).
 - (d) Automotive manufacturers, component/system suppliers and service providers must ensure that there is adequate protection against manipulation and misuse both of the technical structure and of the data and processes.
 - (e) To prevent non-authorized access to vehicles via the "cyberspace" automotive manufacturers, component/system suppliers and service providers shall ensure the secure encryption of data and communications.
 - (f) The system shall be accessible for verifying the measures implemented by automotive manufacturers, component/system suppliers and service providers to ensure cybersecurity and data protection by independent authorised audit.
- 4.2. Data protection.

- 4.2.1. The principle of lawful, fair and transparent processing of personal data means in particular:
- (a) Respecting the identity and privacy of the data subject;
 - (b) Not discriminating against data subjects based on their personal data;
 - (c) Paying attention to the reasonable expectations of the data subjects with regard to the transparency and context of the data processing;
 - (d) Maintaining the integrity and trustworthiness of information technology systems and in particular not secretly manipulating data processing;
 - (e) Taking into account the benefit of data processing depending on the free flow of data, communication and innovation, as far as data subjects have to respect the processing of personal data with regard to the overriding general public interest;
 - (f) Ensuring the preservation of individual mobility data according to necessity and purpose.
- 4.2.2. The means of anonymization and pseudonymization techniques shall be used. Data subjects shall be provided with comprehensive information as to what data is collected and processed in the deployment of connected vehicles and vehicles with ADT, for what purposes and by whom. Data subjects shall give their consent to the collection and processing of their data on an informed and voluntary basis.
- 4.2.3. The collection and processing of personal data shall be limited to data that is relevant in the context of collection. If applicable, the data subject shall have the right to withdraw his or her consent if it involves functions that are not necessary for the operation of their vehicle or for road safety.
- 4.2.4. In addition, appropriate technical and organizational measures and procedures to ensure that the data subject's privacy is respected shall be implemented both at the time of the determination of the means for processing and at the time of the processing. The design of data processing systems installed in vehicles shall be data protection friendly, i.e. taking data protection and cybersecurity aspects into account when planning the components ("privacy by design") as well as designing the basic factory settings accordingly ("privacy by default").
- 4.3. Safety.
- 4.3.1. Standards for the functional safety of critical electric and electronic components or systems in vehicles such as ISO 26262 shall be applied in the light of security-related requirements for connected vehicles and vehicles with ADT.
- 4.3.2. The connection and communication of connected vehicles and vehicles with ADT:
- (a) Shall not influence internal devices and systems generating internal information necessary for the control of the vehicle without appropriate measures;
 - (b) Shall be designed to avoid fraudulent manipulation to the software of connected vehicles and vehicles with ADT as well as fraudulent access of the board information caused by cyber-attacks through:

- (i) Wireless connection;
 - (ii) Wired connection via the diagnosis port, etc.
 - (c) Shall be equipped with measures to ensure a safe mode in case of system malfunction, e.g. by redundancy in the system.
- 4.3.3. When connected vehicles and vehicles with ADT detect fraudulent manipulation by a cyber-attack, the system shall warn the driver and, if appropriate, control the vehicle safely according to the above requirements.
- 4.4. Security.
- 4.4.1. The protection of connected vehicles and vehicles with ADT requires verifiable security measures according security standards (e.g. ISO 27000 series, ISO/IEC 15408).
- 4.4.2. Connected vehicles and vehicles with ADT shall be equipped with:
- (a) Integrity protection measures assuring e.g. secure software updates;
 - (b) Appropriate measures to manage cryptographic keys.
- 4.4.3. The integrity of internal communications between controllers within connected vehicles and vehicles with ADT should be protected e.g. by authentication.
- 4.4.4. Online Services for remote access into connected vehicles and vehicles with ADT should have a strong mutual authentication and assure secure communication (confidential and integrity protected) between the involved entities.
-