Proposal for Supplement 3 to the 03 series of amendments to UN Regulation No. 129

Agenda Item 19

Submitted by the expert from the European Association of Automotive Suppliers*

The text reproduced below was prepared by the expert from the European Association of Automotive Suppliers (CLEPA), to introduce editorial changes in formal document ECE/TRANS/WP.29/GRSP/2019/12.

I. Proposal

Amend paragraph ~~4.8.3-2.3.4~~ to read/

"2.3.4.

"Universal booster cushion" (Non-Integral Universal Enhanced Child Restraint System without a backrest) is a category of Enhanced Child Restraint System without a backrest primarily designed for use in all i-Size and all Universal seating positions. If fitted, ISOFIX attachments are stowable. "

Amend paragraph 4.8.3. to read:

"4.8.3.

.....

Universal booster cushion

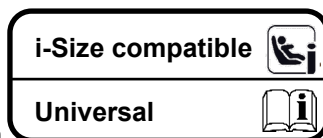

* In accordance with the programme of work of the Inland Transport Committee for 2018–2019 (ECE/TRANS/274, para. 123 and ECE/TRANS/2018/21/Add.1, Cluster 3.1), the World Forum will develop, harmonize and update UN regulations to enhance the performance of vehicles. The present document is submitted in conformity with that mandate.



Amend paragraph 6.1.3.6., to read:

"6.1.3.6

.....

Figure 2

Ruler of measurement device

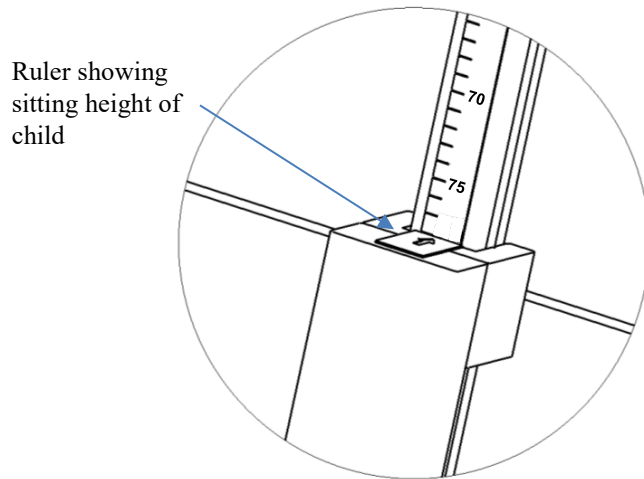

.....

Annex 2, amend to read:

"Annex 2

1. Arrangements of the approval mark

....

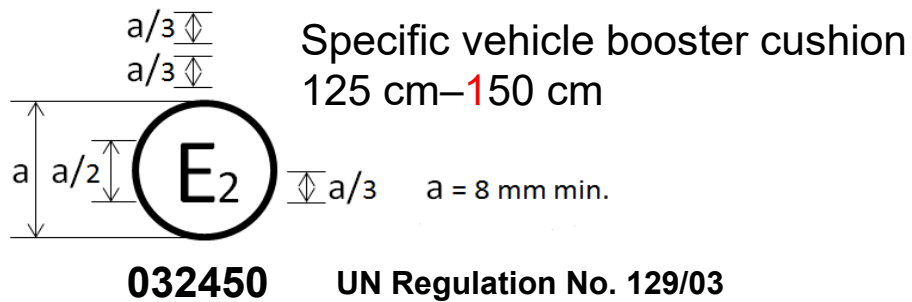

..."

Annex 26 , amend to read :

Annex 26

Lower torso body block test

Figure 1

Manikin block (based on truncated P10)

Material: Expanded polystyrene (EPS) (40 to 45 g/l) or alternative non deformable material

II. Justification

1. Editorial corrections Correction to paragraphs 2.3.4, 4.8.3 and to diagram in Figure 2 paragraph 6.1.3.6 and to the label in Annex 2, in ECE/TRANS/WP.29/GRSP/2019/12.
-