

**Economic and Social Council**Distr.: General
27 February 2014

Original: English

Economic Commission for Europe**Inland Transport Committee****World Forum for Harmonization of Vehicle Regulations****Working Party on Passive Safety****Fifty-fifth session**

Geneva, 19–23 May 2014

Item 18 of the provisional agenda

Regulation No. 129 (Enhanced Child Restraint Systems)**Draft 01 series of amendment to Regulation No. 129****Submitted by the expert from France***

The text reproduced below was prepared by the expert from France to introduce all the modifications needed in UN Regulation No. 129 (Enhanced Child Restraint System (ECRS)) that were suggested by the experts of the informal working group on Child Restraint Systems (IWG CRS) to extend the scope of this Regulation to Non-Integral child restraint systems ("Universal Booster" or "Specific to vehicle Booster") (Phase 2 of the UN Regulation). The modifications to the text of the UN Regulation (including ECE/TRANS/WP.29/2013/110) are marked in bold for new or strikethrough for deleted characters.

* In accordance with the programme of work of the Inland Transport Committee for 2012–2016 (ECE/TRANS/224, para. 94 and ECE/TRANS/2012/12, programme activity 02.4), the World Forum will develop, harmonize and update Regulations in order to enhance the performance of vehicles. The present document is submitted in conformity with that mandate.

I. Proposal

Uniform provisions concerning the approval of enhanced child restraint systems (ECRS) used on board of motor vehicles

Contents

Page

Regulation

1.	Scope	
2.	Definitions.....	
3.	Application for approval	
4.	Markings	
5.	Approval.....	
6.	General specifications	
7.	Tests	
8.	Test reports of type approval and of production qualification	
9.	Production qualification	
10.	Conformity of production and routine tests.....	
11.	Modification and extension of approval of an Enhanced Child Restraint System	
12.	Penalties for non-conformity of production	
13.	Production definitively discontinued.....	
14.	Information for users	
15.	Names and addresses of Technical Services responsible for conducting approval tests and of Type Approval Authorities	
16.	Transitional provisions	

Annexes

1	Communication	
2	Arrangements of the approval mark	
3	Arrangement of apparatus for dust resistance test.....	
4	Corrosion test	
5	Abrasion and microslip test.....	
6	Description of trolley	
	Appendix 1	
	Appendix 2 - Arrangement and use of anchorages on the test trolley	
	Appendix 3 - Definition of side impact door.....	
	Appendix 4 - Stopping device	

7	Curve of trolley's deceleration or acceleration, as function of time
	Appendix 1 - Frontal impact
	Appendix 2 - Rear impact
	Appendix 3 - Lateral impact.....
	Appendix 4
8	Description of dummies
9	Frontal impact test against a barrier
10	Rear impact test procedure
11	Type approval scheme (Flow chart ISO 9002:2000).....
12	Control of conformity of production
13	Test of energy absorbing material
14	Method of defining head impact area of devices with backrests and for rearward-facing devices defining the minimum size of side wings.....
15	Description of conditioning of adjusters mounted directly on Enhanced Child Restraint Systems
16	Typical buckle strength test device
17	Determination of performance criteria
18	Geometrical dimensions of i-Size Enhanced Child Restraint Systems
19	Assessment volumes for i-Size support-legs and support-leg feet
20	Minimum list of documents required for approval.....
21	Load application devices.....
22	Infant carrier module.....
23	Standard safety-belt

1. Scope

This Regulation applies (in its Phases 1 and 2) to Integral Universal ISOFIX **Enhanced** Child Restraint Systems (i-Size) and, **to** Integral Specific vehicle **ISOFIX Enhanced** Child Restraint Systems **and to non-integral Enhanced Child Restraint Systems Universal Booster or Specific to vehicle Booster**, for child occupants of power driven vehicles.

2. Definitions

For the purposes of this Regulation,

2.1. "**Enhanced Child Restraint System**" (ECRS) means a device capable of accommodating a child occupant in a sitting or supine position. It is so designed as to diminish the risk of injury to the wearer, in the event of a collision or of abrupt deceleration of the vehicle, by limiting the mobility of the child's body.

2.2. "**Enhanced Child restraint type**" means a **Enhanced** Child Restraint System which does not differ in such essential respects as:

The category in which the restraint is type approved;

The design, material and construction of the **Enhanced** Child Restraint System.

Convertible or modular **Enhanced** Child Restraint Systems shall be considered to not differ in their design, material and construction.

2.3. "**Integral Universal**" and "**Non-Integral Universal**"

2.3.1. "**i-Size**" (Integral Universal ISOFIX **Enhanced** Child Restraint Systems) is a category of **Enhanced** Child Restraint System for use in all i-Size seating position of a vehicle, as defined and approved according to Regulations Nos. 14 and 16.

[2.3.2. "**Universal Booster**" (Non-Integral Universal **Enhanced** Child Restraint System) is a category of **Enhanced** Child Restraint System for use in all universal "booster vehicle seating positions" of a vehicle suitable for **Enhanced** Child Restraints System of the "universal booster" category, as defined and approved according to Regulations Nos. 14 and 16.

This category is separated in two subcategories:

(a) "**Universal Booster Seat**" with integrated backrest;

(b) "**Universal Booster Cushion**" without backrest].

2.4. "**Integral**" and "**Non-Integral**"

2.4.1. "**Integral**" is a class of **Enhanced** Child Restraint System, meaning that the child is restrained only by components which comprise the **Enhanced** Child Restraint System (e.g. strap harness, impact shield, etc.), and not by means connected directly to the vehicle (e.g. **adult** seat belt).

2.4.2. "**Non-Integral**" is a class of **Enhanced** Child Restraint System, meaning that the retention of the child within the **Enhanced** Child Restraint

System is achieved by means connected directly to the vehicle (e.g. adult seat belt).

- 2.5. "ISOFIX" is a system that provides a method of connecting a **Enhanced** Child Restraint System to a vehicle. It is based on two vehicle anchorages and two corresponding attachments on the **Enhanced** Child Restraint System in conjunction with a means to limit the pitch rotation of the **Enhanced** Child Restraint System. All three vehicle anchorages are to be approved according to Regulation No. 14.
- 2.6. "*ISOFIX Universal*" is an ISOFIX comprising either a top-tether or a support-leg, to limit the pitch rotation of the **Enhanced** Child Restraint System, attached to, or supported by, the corresponding vehicle.
- 2.7. "**Specific vehicle ECRS**"
- 2.7.1. "*Specific vehicle ISOFIX*" is a category of **Integral Enhanced** Child Restraint System connecting to specific vehicle types. All vehicle anchorages are to be approved according to Regulation No. 14. It is also an indication for **Enhanced** Child Restraint Systems including dashboard as a vehicle contact zone.
- 2.7.2. "*Specific vehicle Booster*" is a category of **Non-Integral Enhanced Child Restraint System connecting to specific vehicle types. All vehicle anchorages are to be approved according to Regulation No. 14. This category includes vehicles "Built-in Boosters". This category is separated in two subcategories:**
- (a) "*Specific Vehicle Booster Seat*" with integrated backrest;
- (b) "*Specific Vehicle Booster Cushion*" without backrest.
- 2.8. "Size" indicates the stature of the Child.
- 2.8.1. "**Size range**" is a range for which the **Enhanced** Child Restraint System has been designed and approved.
- 2.8.2. **Enhanced** Child Restraint Systems may cover any size range provided that all requirements of **this regulation** are fulfilled.
- 2.9. "*Orientation*" indicates a direction in which a **Enhanced** Child Restraint System has been approved for use. The following distinctions are made:
- (a) Forward-facing means facing in the normal direction of travel of the vehicle;
- (b) Rearward-facing means facing in the direction opposite to the normal direction of travel of the vehicle;
- (c) Lateral-facing means facing perpendicular to the normal direction of travel of the vehicle.
- 2.10. "*Special Needs Restraint*" is a **Enhanced** Child Restraint System designed for children who have special needs as a result of either a physical or mental disability; this device may in particular permit additional restraining devices for any part of the child, but it shall contain as a minimum a primary means of restraint which complies with the requirements of this Regulation.
- 2.11. "*ISOFIX anchorage system*" means a system made up of **two** ISOFIX low anchorages fulfilling the requirements of Regulation No. 14 which is designed for attaching an ISOFIX **Enhanced** Child Restraint System in conjunction with an anti-rotation device.

- 2.11.1. "ISOFIX low anchorage" means one 6 mm diameter rigid round horizontal bar, extending from vehicle or seat structure to accept and restrain an ISOFIX **Enhanced** Child Restraint System with ISOFIX attachments.
- 2.11.2. "ISOFIX attachment" means one of the two connections, fulfilling the requirement of paragraph 6.3.3. of this Regulation, extending from the ISOFIX **Enhanced** Child Restraint System structure, and compatible with an ISOFIX low anchorage.
- 2.12. "Anti-rotation device" means a device intended to limit the rotation of the **Enhanced** Child Restraint System during a vehicle impact and consisting of:
- (a) A top-tether strap; or
 - (b) A support-leg.
- Meeting** the requirements of this Regulation and fitted to an ISOFIX anchorage system and ISOFIX top tether anchorages or vehicle floor contact surface meeting the requirements of Regulation No. 14.
- An "Anti-rotation device" for a "**Specific** vehicle ISOFIX" **Enhanced** Child Restraint System may comprise a top tether, a support-leg or any other means capable of limiting the rotation.
- 2.13. "ISOFIX top tether strap" means a webbing strap (or equivalent) which extends from the top of an ISOFIX **Enhanced** Child Restraint System to the ISOFIX top tether anchorage, and which is equipped with an adjustment device, a tension-relieving device, and an ISOFIX top tether connector.
- 2.13.1. "ISOFIX top tether anchorage" means a feature fulfilling the requirements of Regulation No. 14, such as a bar, located in a defined zone, designed to accept an ISOFIX top tether connector and transfer its restraint force to the vehicle structure.
- 2.13.2. "ISOFIX top tether connector" means a device intended to be attached to an ISOFIX top tether anchorage.
- 2.13.3. "ISOFIX top tether hook" means an ISOFIX top tether connector typically used to attach an ISOFIX top tether strap to an ISOFIX top tether anchorage as defined in **Figure 3** of Regulation No. 14.
- 2.13.4. "ISOFIX top tether attachment" is a device to secure the ISOFIX top tether strap to the ISOFIX **Enhanced** Child Restraint System.
- 2.14. "Tension relieving device" means a system which allows to release the device that adjusts and maintains the tension in the ISOFIX top tether strap.
- 2.15. "Support-leg" means an anti-rotation device permanently attached to a **Enhanced** Child Restraint System creating a load path between the **Enhanced** Child Restraint System and the vehicle structure. A support-leg shall be adjustable in length (Z direction) and may be additionally adjustable in other directions.
- 2.15.1. "Support-leg foot" means one or more part(s) of the support-leg of the **Enhanced** Child Restraint System intended (by design) to engage with the vehicle floor contact surface and designed to transmit the loading from the support-leg to the vehicle structure during a frontal impact.

- 2.15.2. "Support-leg foot contact surface" means the surface of the support-leg foot physically in contact with the vehicle floor contact surface and designed to spread the loads across the vehicle structure.
- 2.15.3. "Support-leg foot assessment volume" describes a spatial volume which denotes both the extent and limitations for the movement of the support-leg foot. It corresponds to the support-leg foot assessment volume for vehicles, as defined in Annex 10 of Regulation No. 14.
- 2.15.4. "Support-leg dimension assessment volume" means a volume defining the maximum dimensions of a support-leg, corresponding to the support-leg installation assessment volume for vehicles, as defined in Annex 17 of Regulation No. 16, ensuring the dimensional installation of a support-leg of an i-Size ECRS in an i-Size seating position of a vehicle.

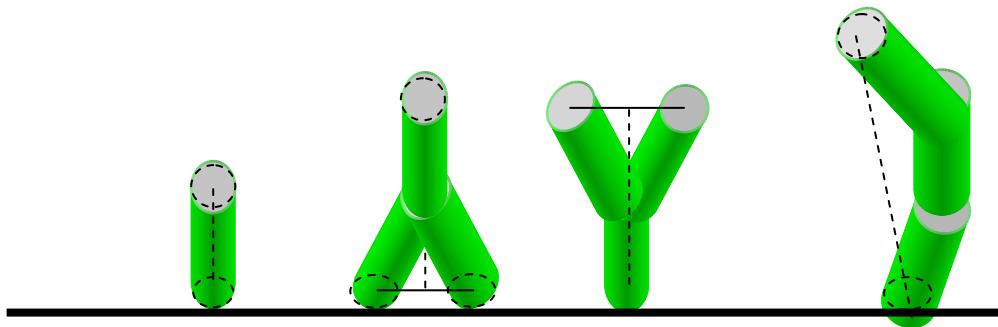

- 2.16. "CRF pitch angle" is the angle between the bottom surface of the fixture "ISO/F2 (B) as defined in Regulation No. 16 (Annex 17, Appendix 2, Figure 2) and the horizontal Z plane of the vehicle as defined in Regulation No. 14 (Annex 4, Appendix 2), with the fixture installed in the vehicle as defined in Regulation No. 16 (Annex 17, Appendix 2).

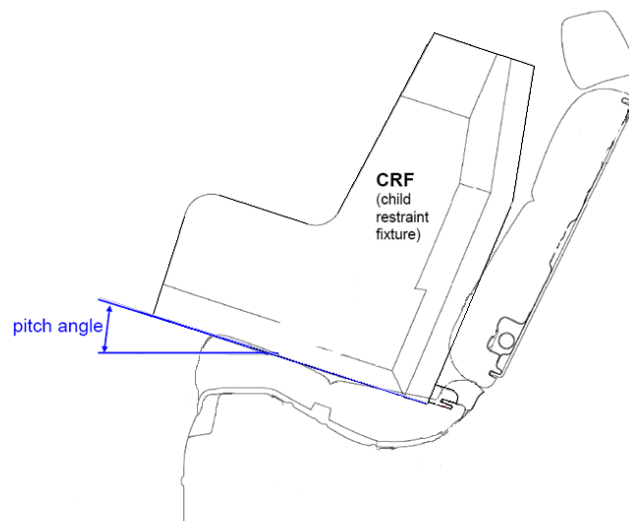

- 2.17. "*Vehicle Seat Fixture (VSF)*"
- 2.17.1.** "**ISOFIX Vehicle seat fixture**" or "**VSF1**" means a fixture, according to ISOFIX size classes whose dimensions are given in Figures 1 to 6 of Appendix 2 to Annex 17 to Regulation No. 16, used by a **Enhanced** Child Restraint System manufacturer to determine the appropriate dimensions of an ISOFIX **Enhanced** Child Restraint System and the location of its ISOFIX attachments.
- [2.17.2.** "**Universal Vehicle booster seat fixture**" or "**VSF2**" means a fixture, according to dimensions given in figure [10] of Annex [17] Appendix [2] of Regulation No. 16, used by a **Enhanced Child Restraint System** manufacturer to determine the appropriate dimensions of a "**Universal Booster**" and its compatibility with most vehicle seating positions, and in particular those which have been assessed according to Regulation No. 16 as being compatible with such a category of **Enhanced Child Restraint System.**]
- 2.18. "*Child-safety chair*" means a **Enhanced** Child Restraint System incorporating a chair in which the child is held.
- 2.19. "*Chair*" means a structure which is a constituent part of the **Enhanced** Child Restraint System and is intended to accommodate a child in a seated position.
- 2.20. "*Chair support*" means that part of a **Enhanced** Child Restraint System by which the chair can be raised.
- 2.21. "**ECRS Belt**" means a **Enhanced Child Restraint System** comprising a combination of straps with a securing buckle, adjusting devices and attachments.
- 2.22. "*Harness belt*" means a **ECRS** belt assembly comprising a lap belt **strap**, shoulder restraints and a crotch strap.
- 2.23. "*Y-shaped belt*" means a **ECRS** belt where the combination of straps is formed by a strap to be guided between the child's legs and a strap for each shoulder.
- 2.24. "*Carry cot*" means a restraint system intended to accommodate and restrain the child in a supine or prone position with the child's spine perpendicular to the median longitudinal plane of the vehicle. It is so designed as to distribute the restraining forces over the child's head and body excluding its limbs in the event of a collision.
- 2.25. "*Carry-cot restraint*" means a device used to restrain a carry-cot to the structure of the vehicle.
- 2.26. "*Infant carrier*" means a restraint system intended to accommodate the child in a rearward-facing semi-recumbent position. It is so designed as to distribute the restraining forces over the child's head and body excluding its limbs in the event of the frontal collision.
- 2.27. "*Child support*" means that part of a **Enhanced Child Restraint System** by which the child can be raised within the **Enhanced Child Restraint System**.
- 2.28. "*Impact shield*" means a device secured in front of the child and designed to distribute the restraining forces over the greater part of the height of the child's body in the event of a frontal impact.
- 2.29. "*Strap*" means a flexible component designed to transmit forces.

- 2.30. "*Lap strap*" means a strap which, either in the form of a complete **ECRS** belt or in the form of a component of such a **ECRS** belt passes across the front of, and restrains, directly or not, the child's pelvis.
- 2.31. "*Shoulder strap*" means that part of a **ECRS** belt which restrains the child's upper torso.
- 2.32. "*Crotch strap*" means a strap (or divided straps, where two or more pieces of webbing make it) attached to the **Enhanced** Child Restraint System and the lap strap and is so positioned as to pass between the child's thighs; it is designed to prevent the child sliding under the lap **belt strap** in normal use and prevent the lap **belt strap** moving up off the pelvis in an impact.
- 2.33. "*Child-restraining strap*" means a strap which is a constituent part of the **ECRS** belt (harness) and restrains only the body of the child.
- 2.34. "*Buckle*" means a quick release device which enables the child to be held by the restraint or the restraint by the structure of the car and can be quickly opened. The buckle may incorporate the adjusting device.
- 2.35. "*Enclosed buckle release button*", a buckle release button such that it shall not be possible to release the buckle using a sphere having a diameter of 40 mm.
- 2.36. "*Non-enclosed buckle release button*", a buckle release button such that it shall be possible to release the buckle using a sphere having a diameter of 40 mm.
- 2.37. "*Adjusting device*" means a device enabling the **ECRS** belt or its attachments to be adjusted to the physique of the wearer. The adjusting device may either be part of the buckle or be a retractor or any other part of the **ECRS** belt.
- 2.38. "*Quick adjuster*" means an adjusting device which can be operated by one hand in one smooth movement.
- 2.39. "*Adjuster mounted directly on **Enhanced** Child Restraint System*" means an adjuster for the harness belt which is directly mounted on the **Enhanced** Child Restraint System, as opposed to being directly supported by the strap that it is designed to adjust.
- 2.40. "*Energy absorber*" means a device which is designed to dissipate energy independently of or jointly with the strap and forms part of a **Enhanced** Child Restraint System.
- 2.41. "*Retractor*" means a device designed to accommodate a part or the whole of the strap of a **Enhanced** Child Restraint System. The term covers the following devices:
- 2.41.1. "*Automatically-locking retractor*", a retractor which allows extraction of the desired length of a strap and, when the buckle is fastened, automatically adjusts the strap to the wearer's physique, further extraction of the strap without voluntary intervention by the wearer being prevented.
- 2.41.2. "*Emergency-locking retractor*", a retractor which does not restrict the strap wearer's freedom of movement in normal driving conditions. Such a device has length-adjusting devices which automatically adjust the strap to the wearer's physique, and a locking mechanism actuated in an emergency by:
- 2.41.2.1. Deceleration of the vehicle, extraction of the strap from the retractor, or any other automatic means (single sensitivity);

- 2.41.2.2. A combination of any of these means (multiple sensitivity).
- 2.42. "*Inclined position*" means a special position of the chair which allows the child to recline.
- 2.43. "*Lying down/supine/prone position*" means a position where at least the child's head and body excluding its limbs are on a horizontal surface when at rest in the restraint.
- 2.44. "*Vehicle seat*" means a structure, which may or may not be integral with the vehicle structure, complete with trim and intended to seat one adult person. In this respect:
- 2.44.1.** "*Group of vehicle seats*" means either a bench seat or a plurality of seats which are separate but side by side (i.e. so fixed that the front anchorages of one seat are in line with the front or rear anchorages of another seat or on a line passing between those anchorages), each seat accommodating one or more seated adult persons.
- 2.44.2.** "*Vehicle bench seat*" means a structure complete with trim and intended to seat more than one adult person.
- 2.44.3.** "*Vehicle front seats*" means the group of seats situated foremost in the passenger compartment, i.e. having no other seat directly in front of them.
- 2.44.4.** "*Vehicle rear seats*" are fixed, forward-facing seats situated behind another group of vehicle seats.
- 2.45. "*Seat type*" means a category of adult seats which do not differ in such essential respects as the shape, dimensions and materials of the seat structure, the types and dimensions of the seat-lock adjustment and locking systems, and the type and dimensions of the adult safety-belt anchorage on the seat, of the seat anchorage, and of the affected parts of the vehicle structure.
- 2.46. "*Adjustment system*" means the complete device by which the vehicle seat or its parts can be adjusted to suit the physique of the seat's adult occupant; this device may, in particular, permit longitudinal displacement, and/or vertical displacement, and/or angular displacement.
- 2.47. "*Vehicle seat anchorage*" means the system, including the affected parts of the vehicle structure, by which the adult seat as a whole is secured to the vehicle structure.
- 2.48. "*Displacement system*" means a device enabling the adult seat or one of its parts to be displaced angularly or longitudinally, without a fixed intermediate position, to facilitate the entry and exit of passengers and the loading and unloading of objects.
- 2.49. "*Locking system*" means a device ensuring that the adult seat and its parts are maintained in the position of use.
- 2.50. "*Seat bight*" means the area close to the intersection of the surfaces of the vehicle seat cushion and the seat-back.
- 2.51. "*ECRS position*"**
- 2.51.1. "*ISOFIX position*" means a location which allows for the installation of either:
- (a) Universal ISOFIX **Enhanced** Child Restraint System as defined in Regulation No. 44; or

- (b) A "specific vehicle ISOFIX" **Enhanced** Child Restraint System as defined in Regulation No. 44 or a "specific vehicle ISOFIX" as defined in this Regulation; or
 - (c) An i-Size **Enhanced** Child Restraint System suitable for use in specific ISOFIX seating positions as defined by the vehicle manufacturer according to Regulation 16.
- [2.51.2. **"Universal Vehicle booster seating position" means a location which allows for the installation of a "Universal Booster" Enhanced Child Restraint System as defined in this Regulation.]**
- 2.52. *"Type approval test"*, means a test to determine the extent to which a **Enhanced** Child Restraint System type submitted for approval is capable of satisfying the requirements.
- 2.53. *"Production qualification test (qualification of production test)"*, means a test to determine whether the manufacturer is able to produce a **Enhanced** Child Restraint System in conformity with the **Enhanced** Child Restraint Systems submitted for type approval.
- 2.54. *"Routine testing"* (or conformity of production testing), means the testing of a number of restraint systems selected from a single batch to verify the extent to which they satisfy the requirements.
- 2.55. *"Shoulder strap positioner"* means a device intended to maintain, ~~during normal transit conditions~~, the appropriate shoulder strap position on the child's torso, **during normal transit conditions** by connecting the shoulder straps to one another.
- 2.56. **"Lock-off device" which locks and prevents movement of one section of the webbing of an adult safety-belt relative to another section of the webbing of the same belt. Such devices may act upon either diagonal or lap section or secure together both lap and diagonal sections of the adult belt. The term covers the following classes :**
- 2.56.1. **"Class A device"**, a device that prevents the child pulling webbing from the retractor through to the lap part of the belt, when the adult belt is used to restrain the child directly.
- 2.56.2. **"Class B device"**, a device that allows the retention of an applied tension in the lap part of an adult safety-belt, when the adult belt is used to restrain the **Enhanced** Child Restraint System. The device is intended to prevent webbing slipping from the retractor through the device, which would release the tension and place the restraint in a non-optimal position (to be used in phase III).

3. Application for approval

- 3.1. The application for approval of a type of **Enhanced** Child Restraint System shall be submitted by the holder of the trade mark or by his duly accredited representative and follow the type approval scheme described in Annex 11.
- 3.2. The application for approval, relating to each type of **Enhanced** Child Restraint System, shall be accompanied by:
 - 3.2.1. A technical description of the **Enhanced** Child Restraint System, specifying the straps and other materials used together with the predicted and

reproducible behaviour of load limiting devices. It shall be accompanied by drawings of the parts making up the **Enhanced** Child Restraint System and in the case of retractors, installation instructions for these retractors and their sensing devices, declaration on toxicity (para. 6.3.1.1.) and flammability (para. 6.3.1.2.), the drawings shall show the position intended for a single approval number and additional symbol(s) in relation to the circle of the approval mark.

- 3.2.2. The applicant shall indicate the kind of application:
- (a) Application for an i-Size **Enhanced** Child Restraint Systems; or
 - (b) Application for a Specific vehicle ISOFIX; **or**
 - (c) **Application for a Universal Booster Enhanced Child Restraint System; or**
 - (d) **Application for a Specific to vehicle Booster Enhanced Child Restraint System.**
- 3.2.3. For **Enhanced** Child Restraint Systems tested on the test trolley in a vehicle body shell in conformity with paragraph 7.1.3.2. of this Regulation or in a complete vehicle in conformity with paragraph 7.1.3.3. of this Regulation, the applicant shall submit documentation (drawings and/or pictures) regarding the combination of the **Enhanced** Child Restraint System and the car or the ISOFIX seating position and the relevant car environment for which the manufacturer has requested a Specific vehicle ~~ISOFIX~~ approval. This documentation needs to indicate:
- (a) The available area around the **Enhanced** Child Restraint System when installed on the **vehicle** seating position. In particular it shall include parts which might interfere with the **Enhanced** Child Restraint System during an impact;
 - (b) All relevant vehicle parts which might influence the (rotational) movement of the **Enhanced** Child Restraint System during an impact, due to their strength or stiffness.
- 3.2.4. Samples of the **Enhanced** Child Restraint System requested by the Technical Service responsible for conducting the test;
- 3.2.5. A 10-metre length of each type of strap used in the **Enhanced** Child Restraint System; and
- 3.2.6. Instructions and details of packaging in accordance with paragraph 14. of this Regulation.
- 3.2.7. In case of a "Specific vehicle ~~ISOFIX~~" application when tests are performed in a vehicle body shell, a body of the vehicle, including adult seats and the relevant parts of the car environment shall be available.
- 3.3. Annex 20 lists the minimum documents required to accompany the application for approval as indicated in paragraph 3.2. above and required elsewhere in this Regulation.
- 3.4. The Type Approval Authority of a Contracting Party shall verify, before granting type approval the existence of satisfactory arrangements and procedures for ensuring effective control so that **Enhanced** Child Restraint Systems, equipment or parts when in production conform to the approved type.

4. Markings

- 4.1. The samples of **Enhanced** Child Restraint Systems submitted for approval in conformity with the provisions of paragraphs 3.2.4. and 3.2.5. above shall be clearly and indelibly marked with the manufacturer's name, initials or trade mark.
- 4.2. The **Enhanced** Child Restraint System, except the strap(s) or harness, shall be marked clearly and indelibly with the year of production.
- 4.3. The orientation of the **Enhanced** Child Restraint System relative to the vehicle shall be clearly indicated on the product.

If the Enhanced Child Restraint System is to be used in combination with an adult safety belt, the correct routing of the webbing shall be clearly indicated by means of a drawing permanently attached to the Enhanced Child Restraint System. If the restraint is held in place by the adult safety-belt, the routes of the webbing shall be clearly marked on the product by colour coding. The colours for the safety-belt route to be used when the device is installed forward facing shall be red and when installed rear-facing shall be blue. The same colours shall also be used on the labels on the device that illustrate the methods of use.

There shall be a clear differentiation between the intended routes for the lap section and the diagonal section of the safety belt. Indication such as colour coding, words, shapes, etc. shall distinguish each section of the safety belt.

The marking defined in this paragraph shall be visible with the **Enhanced** Child Restraint System in the vehicle, with the child in the **Enhanced** Child Restraint System.

- 4.4. On the visible inner surface (including the side wing beside the child's head) in the approximate area where the child's head rests within the **Enhanced** Child Restraint System, rearward facing restraints shall have the following **label permanently attached** (the information shown is a minimum).

Label minimum size: 60 x 120 mm.

The label shall be stitched to the cover around its entire perimeter and/or permanently bonded to the cover over its entire back surface. Any other form of attachment that is permanent and not liable to removal from the product or to becoming obscured is acceptable. Flag type labels are specifically prohibited.

If sections of the restraint or any accessories supplied by the **Enhanced** Child Restraint System manufacturer are able to obscure the label an additional label is required. One warning label shall be permanently visible in all situations when the restraint is prepared for use in any configuration.



- 4.5. In the case of **Enhanced** Child Restraint Systems that can be used forward facing, it shall have the following label permanently attached and visible to the person installing a **Enhanced Child Restraint System** in the vehicle:

The manufacturer shall be permitted to include the word "months" to explain the symbol "M" in the label. The word "months" should be in a language commonly spoken in the country or countries where the product is sold. More than one language is allowed.

Minimum label size 40 x 40 mm

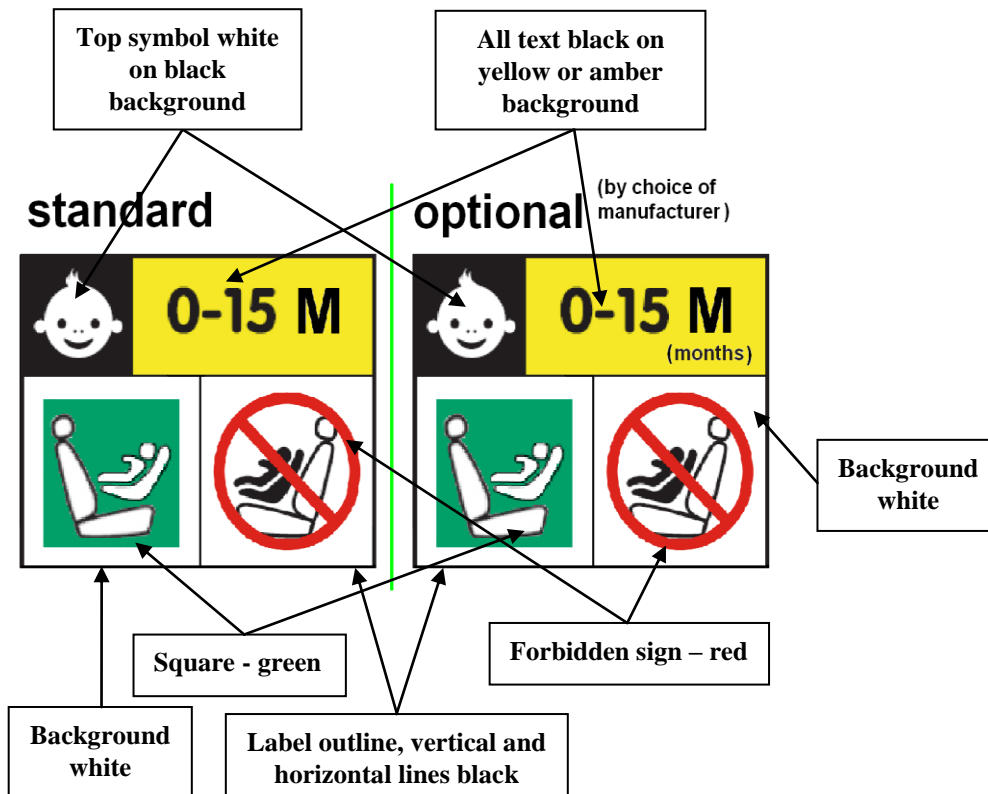

- 4.5.1 The size range of the Enhanced Child Restraint System in centimeters;
- 4.5.2 The maximum occupant mass allowed for the Enhanced Child Restraint System in kilograms.

- 4.6. **Marking for ECRS including ISOFIX connections** ~~i-Size marking~~ :

One of the following information **labels** shall be permanently visible to someone installing the **Enhanced** Child Restraint System in a vehicle:

- 4.6.1. **The i-Size ECRS:**

i-Size logo. The symbol shown below shall have minimum dimension of 25 x 25 mm and the pictogram shall contrast with the background. The pictogram shall be clearly visible either by means of contrasting colors or by adequate relief if it is molded or embossed;

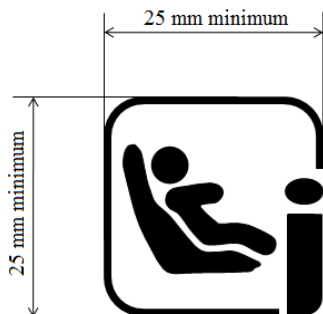

- 4.6.2. ~~The size range of the Child Restraint System in centimeters;~~
- 4.6.3. ~~The maximum occupant mass allowed for the Child Restraint System in kilograms.~~

4.6.2. **ISOFIX specific to vehicle ECRS:**



The *Specific vehicle ISOFIX Enhanced* Child Restraint System shall have a permanently attached label visible to the person installing the **Enhanced** Child Restraint System in the car, containing the following information:

Specific Vehicle ISOFIX 

4.7. **Booster marking**

- 4.7.1. **Universal booster Enhanced Child Restraint System shall have a permanently attached label, visible to the person installing the Enhanced Child Restraint System in the car, containing the following information:**

Universal booster 

- 4.7.2. **The *Specific vehicle booster* Enhanced Child Restraint System shall have a permanently attached label, visible to the person installing the Enhanced Child Restraint System in the car, containing the following information:**

Specific vehicle booster 

4.8. Additional markings

The following information may be conveyed by pictograms and/or text. The marking shall indicate:

- (a) The essential relevant steps needed for making the **Enhanced** Child Restraint System ready for installation. For example, the method of extending the ISOFIX attachment(s) shall be explained;
- (b) The position, function, and interpretation of any indicator shall be explained;
- (c) The position and if necessary the routing of top tethers, or other means of limiting **Enhanced** Child Restraint System rotation requiring action by the user, shall be indicated using one of the following symbols as appropriate;

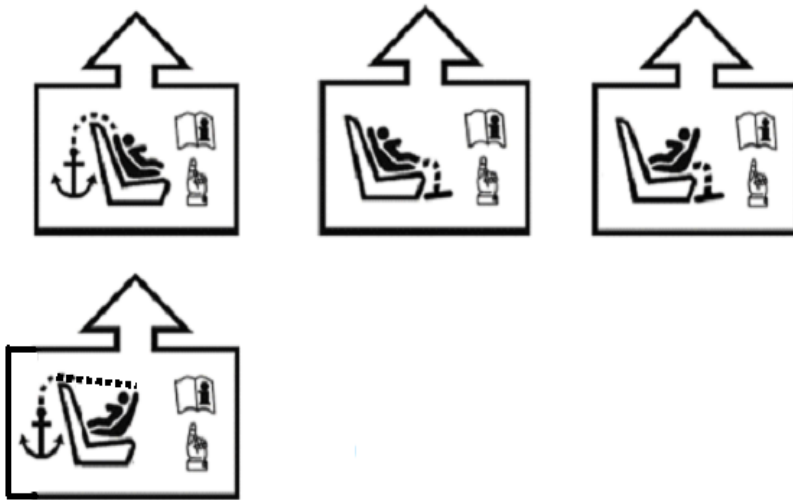

- (d) The adjustment of ISOFIX latches and the top tether, or other means of limiting **Enhanced** Child Restraint System rotation, requiring action by the user shall be indicated;
- (e) The marking shall be permanently attached and be visible to a user installing the **Enhanced** Child Restraint System;
- (f) Where necessary reference should be made to the **Enhanced** Child Restraint System user instructions and to the location of that document using the symbol below.



5. Approval

- 5.1. Each sample submitted in conformity with paragraphs 3.2.4. and 3.2.5. above shall meet the specifications set forth in paragraphs 6. to 7. of this Regulation in every respect before approval can be granted.
- 5.2. An approval number shall be assigned to each type approved. Its first two digits (at present 00 corresponding to the 00 series of amendments which entered into force on 9 July 2013) shall indicate the series of amendments incorporating the most recent major technical amendments made to the Regulation at the time of issue of the approval. The same Contracting Party shall not assign the same number to another type of **Enhanced** Child Restraint System covered by this Regulation.

A type of **Enhanced** Child Restraint System approved according to this Regulation shall not bear another approval mark according to Regulation No. 44 (**Enhanced** Child Restraint Systems).
- 5.3. Notice of approval or of extension or refusal of approval of a **Enhanced** Child Restraint System pursuant to this Regulation shall be communicated to the Parties to the Agreement which apply this Regulation by means of a form conforming to the model in Annex 1 to this Regulation.
- 5.4. In addition to the marks prescribed in paragraph 4. above, the following particulars shall be affixed in a suitable space to every **Enhanced** Child Restraint System conforming to a type approved under this Regulation:
 - 5.4.1. An international approval mark consisting of:
 - 5.4.1.1. A circle surrounding the letter "E" followed by the distinguishing number of the country which has granted approval;¹
 - 5.4.1.2. An approval number; the words "Regulation No." followed by the number of this regulation, a slash and the series of amendment ("Regulation No. XXX/XX");

¹ The distinguishing number of the Contracting Parties to the 1958 Agreement are reproduced in Annex 3 to the Consolidated Resolution on the Construction of Vehicles (R.E.3), document TRANS/WP.29/78/Rev.2/Amend.3.

- 5.4.2. The following additional symbols:
- 5.4.2.1. The words "i-Size universal ISOFIX", or "**universal booster**", or "specific vehicle ISOFIX" or "**specific vehicle booster**" depending on the category of **Enhanced** Child Restraint System;
- 5.4.2.2. The size range for which the **Enhanced Child Restraint System** has been designed;
- ECRS which can be converted into another configuration for taller children must accommodate an uninterrupted range of child statures.**
- Note: As an example, a booster shall not have a range of 100 cm to 130 cm and then an "interruption" before accommodating children from 140 cm to 150 cm.**
- 5.4.2.3. The symbol "S" in the case of a "Special Needs Restraint".
- 5.5. Annex 2 to this Regulation gives an example of the arrangement of the approval mark.
- 5.6. The particulars referred to in paragraph 5.4. above shall be clearly legible and be indelible, and may be affixed either by means of a label or by direct marking. The label or marking shall be resistant to wear.
- 5.7. The labels referred to in paragraph 5.6. above may be issued either by the Type Approval Authority which has granted the approval or, subject to that Type Approval Authority's authorization, by the manufacturer.

6. General specifications

- 6.1. Positioning and securing on the vehicle
- 6.1.1. **Enhanced** Child Restraint Systems in the i-Size category are for use in i-Size seating positions, when the **Enhanced** Child Restraint Systems are fitted in conformity with the vehicle manufacturer's instructions.
- [Enhanced Child Restraint Systems in the ~~Specific~~ universal booster category are for use in all universal vehicle booster seating positions.]**
- Enhanced** Child Restraint Systems in the specific vehicle ISOFIX category are for use in all ISOFIX positions and also in the luggage area, if the restraints are fitted in conformity with the vehicle manufacturer's instructions.
- Enhanced Child Restraint Systems in the specific vehicle booster category are for use in the vehicle booster seating position if they are fitted in conformity with the vehicle manufacturer's instructions.**
- 6.1.2. According to the category in which it belongs to, see Table 1, the **integral Enhanced** Child Restraint System shall be secured to the vehicle structure or to the vehicle seat structure:
- 6.1.2.1. For i-Size category, this shall be by means of two ISOFIX attachments with the addition of an anti-rotation device for both forward and rearward-facing **Enhanced** Child Restraint System;
- 6.1.2.2. For Specific Vehicle ISOFIX category: this shall be by means of the ISOFIX attachments designed by the manufacturer of the **Enhanced** Child Restraint System, secured to ISOFIX anchorage system as designed by the vehicle manufacturer.

Table 1
Possible configurations for type approval for **Integral Enhanced Child Restraint Systems**

	<i>Orientation</i>	<i>Category</i>	
		<i>i-Size ECRS</i>	<i>Integral Specific Vehicle ISOFIX ECRS</i>
INTEGRAL	Lateral facing (carry-cot)	NA	A
	Rearward facing	A	A
	Forward facing (integral)	A	A

With:

ECRS: Enhanced Child Restraint System-

A: Applicable

NA: Non-Applicable

6.1.2.3. For children under the age of 15 months only lateral facing or rearward facing **Enhanced** Child Restraint System shall be used. That means:

- (a) A **Enhanced** Child Restraint System designed for children up to 15 months of age shall be rearward facing and accommodate at least a child with a stature of 83 cm;
- (b) A forward facing **Enhanced** Child Restraint System shall not be designed to accommodate a stature below 71 cm;
- (c) A convertible seat in its rearward facing configuration shall be able to accommodate a child with a stature up to 83 cm. This shall not preclude a child stature greater than 83 cm.

The use of rearward facing **Enhanced** Child Restraint System may be applied to any age of child.

6.1.3. According to the category as defined by Table 2, the Non-Integral Enhanced Child Restraint System and the child shall be secured in a vehicle seating position:

6.1.3.1. For Universal Booster category, this shall be by means of the adult safety seat belt and possibly with ISOFIX attachments if these are stowable.

6.1.3.2. For Specific Vehicle Booster category, this shall be by means of the adult safety seat belt and possibly with attachments designed by the manufacturer of the Enhanced Child Restraint System, secured to anchorages as designed by the vehicle manufacturer.

Table 2
Possible configurations for type approval for Non-Integral Enhanced Child Restraint Systems

	<i>Orientation</i>	<i>Subcategory</i>	<i>Category</i>
Non Integral	Forward Facing		Universal Booster
			Specific Vehicle Booster (Built- in included)
		Booster Seat	A
		Booster Cushion	A
	Rearward Facing	Booster Seat & Booster Cushion	NA

A: Applicable

NA: Non-Applicable

- 6.1.3.3.** Non integral Enhanced Child Restraint System shall not be designed to accommodate a stature below [100 cm].
- 6.1.3.4.** Enhanced Child Restraint Systems of the Universal Booster category shall have a main load-bearing contact point, between the Enhanced Child Restraint System and the adult safety-belt. This point shall not be less than 150 mm from the Cr axis when measured with the Enhanced Child Restraint System on the dynamic test bench installed in accordance with paragraph 7.1.3.5.2.2. of this Regulation, without a dummy. This shall apply to all adjustment configurations and variable belt routings.
- 6.1.3.5.** If the adult seat belt is required to secure a universal booster category Enhanced Child Restraint System on the dynamic test bench, then this seat belt is defined in Annex 24 to this Regulation. The Enhanced Child Restraint System shall be secured onto the test bench using the appropriate standard seat belt described in Annex 23. The dummy shall not be installed unless the design of the restraint is such that the installation of a dummy would increase the amount of belt used. With the Enhanced Child Restraint System in the installed position, there shall be no tension in the belt, apart from that exerted by the standard retractor, where fitted. Where the retractor belt is used, this condition shall be met with at least 150 mm of belt remaining on the spool.
- 6.2.** Configuration of the Enhanced Child Restraint System
- 6.2.1.** The configuration of the **Enhanced** Child Restraint System shall be such that:
- 6.2.1.1.** The restraint of the child shall give the required protection in any position specified for the **Enhanced** Child Restraint System;
- For Special Needs Restraints the primary means of restraint shall give the required protection in any intended position of the **Enhanced** Child Restraint System without the use of the additional restraining devices which may be present;
- 6.2.1.2.** The **Enhanced** Child Restraint System shall be such that the child may be easily and readily restrained or removed. In the case of a **Enhanced** Child

Restraint System in which the child is restrained by means of a harness belt or a Y-shaped belt without a retractor each shoulder restraint and lap strap shall be capable of movement relative to each other during the procedure prescribed in paragraph 6.7.1.4. below; in these cases of the **Enhanced** Child Restraint System belt assembly may be designed with two or more connecting parts.

For Special Needs Restraints it is recognized that the additional restraining devices will restrict the speed by which a child can be restrained and removed. However, the additional devices shall be designed to release quickly so far as possible;

6.2.1.3. If it is possible to change the inclination of the **Enhanced** Child Restraint System, this change in inclination shall not require manual readjustment of any other part of the **Enhanced** Child Restraint System. A deliberate hand-action shall be necessary in order to change the inclination of the **Enhanced** Child Restraint System;

6.2.1.4. To prevent submarining, either by impact or through restlessness, a crotch strap shall be required on all **integral** forward-facing restraints incorporating an integral harness belt system.

Note: The Q serie of dummies have provisions to include pressure based abdominal sensors in the near future. Related injury criteria are under development.

6.2.1.5. All restraint devices utilizing a "lap strap" must positively guide the "lap strap" to ensure that the loads transmitted by the "lap strap" are transmitted through the pelvis. The assembly shall not subject weak parts of the child's body (abdomen, crotch, etc.) to excessive stresses.

Moreover, the design shall be such that compression loads shall not be imposed on the crown of the child's head in the event of a collision;

6.2.1.6. **For the universal or specific vehicle boosters, the lap portion of the adult seat belt shall be positively guided to ensure that the loads transmitted by the adult lap belt are transmitted through the pelvis. The shoulder belt portion of the adult safety belt shall be positively guided to ensure that the child torso and neck do not escape.**

6.2.1.7. All straps of the restraint shall be so placed that they cannot cause discomfort to the wearer in normal use or assume a dangerous configuration. The distance between the shoulder-straps in the vicinity of the neck should be at least the width of the neck of the appropriate dummy.

6.2.1.8. With the crotch strap attached and in its longest position if adjustable, it shall not be possible to adjust the lap strap to lie above the pelvis of both the smallest and largest dummy within the ~~mass groups~~ **"size range"** covered by the approval. For all forward-facing restraints, it shall not be possible to adjust the lap strap to lie above the pelvis of both the smallest and largest dummy within the ~~mass groups~~ **"size range"** covered by the approval.

6.2.1.9. During the dynamic test, as prescribed in paragraph 7.1.3., the lap belt shall not pass fully beyond the pelvic structure of the dummy during the period prior to maximum horizontal head excursion. An assessment shall be carried out using high speed video imaging.

- 6.2.1.10. At least worst case configuration of dynamic test must be performed on the Enhanced Child Restraint System preconditioned according to paragraphs 7.2.6.**
- 6.2.2. The **Enhanced** Child Restraint System shall be designed and installed so as to:
- 6.2.2.1. Not exhibit sharp edges or protrusions liable to cause damage to vehicle-seat covers or to occupant's clothing;
- 6.2.2.2. To ensure that its rigid parts do not, at any point, where they are in contact with straps, exhibit sharp edges capable of abrading the straps.
- 6.2.3. It shall not be possible to remove or detach without the use of specific tools, any components not designed to be removable or detachable. Any components that are designed to be removable for maintenance or adjustment purpose shall be so designed as to avoid any risk of incorrect assembly and use, as the assembly and disassembly processes shall be explained in detail in the restraint user guides. Any harness belt shall be capable of its full range of adjustment without disassembly.
- 6.2.4. "Special Needs Restraints" may have additional restraining devices; these shall be designed to avoid any risk of incorrect assembly, and shall be designed so that their means of release and mode of operation is immediately obvious to any rescuer in an emergency.
- 6.2.5. An **Enhanced** Child Restraint System may be designed for use in any ~~range~~ ~~of-size~~ range specified by the manufacturer provided that it satisfies the requirements laid down in this Regulation.
- 6.2.6. **Enhanced** Child Restraint Systems incorporating inflatable elements shall be so designed that the conditions of use (pressure, temperature, humidity) have no influence on their ability to comply with the requirements of this Regulation.
- 6.3. **Enhanced** Child Restraint System specifications
- 6.3.1 Material
- 6.3.1.1. The **Enhanced** Child Restraint System manufacturer shall declare in writing that the toxicity of materials used in the manufacture of restraint systems and accessible to the restrained child is in conformity with the relevant parts of EN 71-3:1994 **in its last edited version.** ~~A1-2000/AC~~ Tests confirming the validity of the declaration may be carried out at the discretion of the Technical Service.
- 6.3.1.2. The **Enhanced** Child Restraint System manufacturer shall declare in writing that the flammability of materials used to manufacture the **Enhanced Child Restraint System** is in conformity with the relevant paragraphs of EN 71-2 **in its last edited version.** Tests confirming the validity of the declaration may be carried out at the discretion of the Technical Service.
- 6.3.2. General characteristics
- 6.3.2.1. Internal geometric characteristics
- The Technical Service conducting the approval tests shall verify that the internal dimensions of the **Enhanced** Child Restraint System conform to the requirements of Annex 18. For any size within the size range declared by the manufacturer the ~~minimum~~ dimensions for **minimum** shoulder breadth,

minimum hip breadth and **minimum** sitting height shall be fulfilled together with ~~as well as~~ the **dimensions for minimum and maximum shoulder height**.

6.3.2.2. External dimensions

6.3.2.2.1. Integral Class Enhanced Child Restraint Systems

The maximum dimensions for width, height and depth of the **Enhanced** Child Restraint System and the locations of the ISOFIX anchorages system with which its attachments shall engage, shall be defined by the Vehicle Seat Fixture (VSF1) as defined in paragraph 2.17.1. of this Regulation.

- (a) i-Size Forward facing **Enhanced** Child Restraint Systems shall fit within the ISO/F2x size envelope for a reduced-height forward-facing toddler ECRS ISOFIX SIZE CLASS B1;
- (b) i-Size Rearward facing **Enhanced** Child Restraint Systems shall fit within the ISO/R2 size envelope for a reduced-size rearward-facing toddler ECRS ISOFIX SIZE CLASS D;
- (c) Specific vehicle ISOFIX **Enhanced** Child Restraint Systems **shall fit in vehicle(s) specified or shall ~~may fit within any~~ at least in one of ISO (R1, R2, R3, F2, F2X, F3, L1, L2) size envelope.**

6.3.2.2.2. Non-Integral Class Enhanced Child Restraint Systems

The maximum dimensions for width, height and depth of the Enhanced Child Restraint System and the locations of the ISOFIX anchorages system if any, with which its attachments shall engage, shall be defined by the Vehicle Seat Fixture (VSF2) as defined in paragraph 2.17.2. of this Regulation.

- (a) **Universal Booster Enhanced Child Restraint Systems shall fit within the ISO/Fxxx size envelope.**
- (b) **Specific Vehicle Booster Enhanced Child Restraint Systems shall fit in vehicle(s) specified by the child seat manufacturer.**

6.3.2.3. Mass

The mass of an integral ISOFIX **Enhanced** Child Restraint System (i-Size **Enhanced** Child Restraint System included) combined with the mass of the largest child intended to use the **Enhanced** Child Restraint System shall not exceed 33 kg. This mass limit is also applicable for Specific vehicle ISOFIX **Enhanced** Child Restraint Systems.

6.3.3. ISOFIX attachments

6.3.3.1. Type

ISOFIX attachments may be according to examples shown in Figure 0(a), or other appropriate designs that are part of a rigid mechanism having provision for adjustment, the nature of which is determined by the ISOFIX **Enhanced** Child Restraint System manufacturer.

Figure 0(a)

Key

- 1 ISOFIX **Enhanced** Child Restraint System attachment — example 1
- 2 ISOFIX **Enhanced** Child Restraint System attachment — example 2

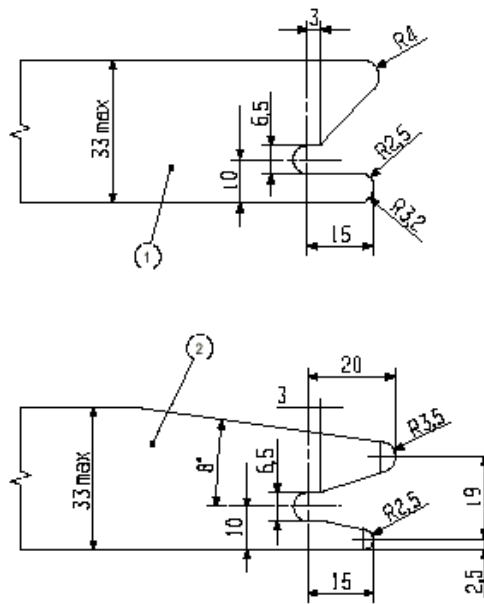

Dimensions in mm

6.3.3.2. Dimensions

Dimensions for the portion of the ISOFIX **Enhanced** Child Restraint System attachment that engages the ISOFIX anchorage system shall not exceed the maximum dimensions given by the envelope in Figure 0(b).

Figure 0(b)

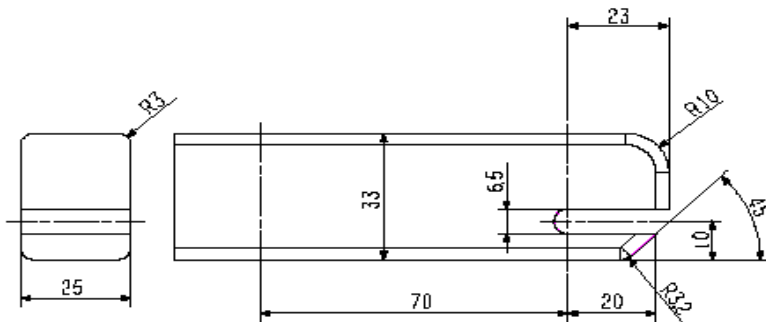

Dimensions in mm

6.3.3.3. Partial latching indication

The ISOFIX **Enhanced** Child Restraint System shall incorporate means by which there is a clear indication that both of the ISOFIX attachments are completely latched with the corresponding ISOFIX lower anchorages. The indication means may be audible, tactile or visual or a combination of two or more. In case of visual indication it shall be detectable under all normal lighting conditions.

6.3.4. ISOFIX **Enhanced** Child Restraint System top tether strap specifications

6.3.4.1. Top tether connector

The top tether connector shall be ISOFIX top tether hook as shown in Figure 0(c), or similar devices that fit within the envelope given by Figure 0(c).

6.3.4.2. ISOFIX top tether strap features

The ISOFIX top tether strap shall be supported by webbing (or its equivalent), having a provision for adjustment and release of tension.

6.3.4.2.1. ISOFIX Top tether strap length

ISOFIX **Enhanced** Child Restraint System top tether strap length shall be at least 2,000 mm.

6.3.4.2.2. No-slack indicator

The ISOFIX top tether strap or the ISOFIX **Enhanced** Child Restraint System shall be equipped with a device that will indicate that all slack has been removed from the strap. The device may be part of an adjustment and tension relieving device.

6.3.4.2.3. Dimensions

Engagement dimensions for ISOFIX top tether hooks are shown in Figure 0(c).

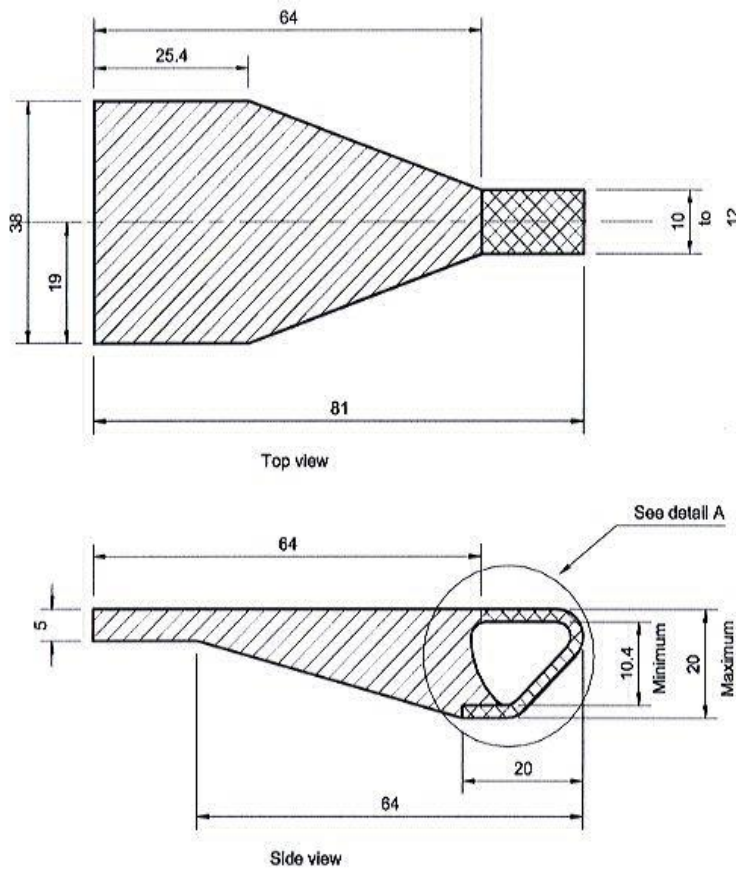

Figure 0(c)
ISOFIX top tether connector (hook type) dimensions

Dimensions in millimetres

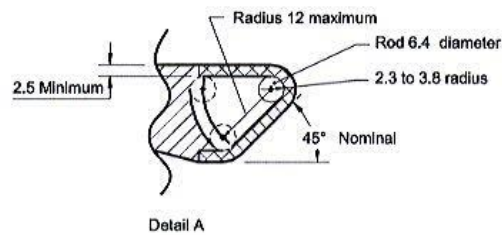



LEGEND:

-  Surrounding structure (if present)
-  Area in which the tether strap hook interface profile must be wholly located.

6.3.5. i-Size **Enhanced** Child Restraint System support-leg and support-leg foot requirements

i-Size **Enhanced** Child Restraint Systems fitted with support-legs must comply in all positions of use (e.g. in case of length adjustable attachment, base, etc. the shortest and longest position) with the geometrical provisions defined in this paragraph and its subparagraphs.

Compliance with the requirements specified in paragraphs 6.3.5.1. and 6.3.5.2. below may be verified by a physical or computer simulation.

The geometrical requirements in paragraphs 6.3.5.1. to 6.3.5.4. below are referenced to a coordinate system, whose origin is located centrally between the two ISOFIX attachments and on the centreline of the corresponding ISOFIX anchorage system.

The orientation of the axes of the coordinate system is referenced to the **Enhanced Child Restraint System** fixture(s):

- (a) The X' axis shall be parallel to the **Enhanced Child Restraint System Fixture (CRF)**² bottom surface and in the median longitudinal plane of the CRF;
- (b) The Y' axis shall be perpendicular to the median longitudinal plane;
- (c) The Z' axis shall be perpendicular to the CRF bottom surface.

In fulfilling the requirements of this section, the **Enhanced Child Restraint System** shall be installed in accordance with the user manual of the **Enhanced Child Restraint System**. The storage position of the support-leg is excluded from these requirements.

² Child Restraint Fixture (CRF) as defined in Regulation No. 16 (Safety-belts).

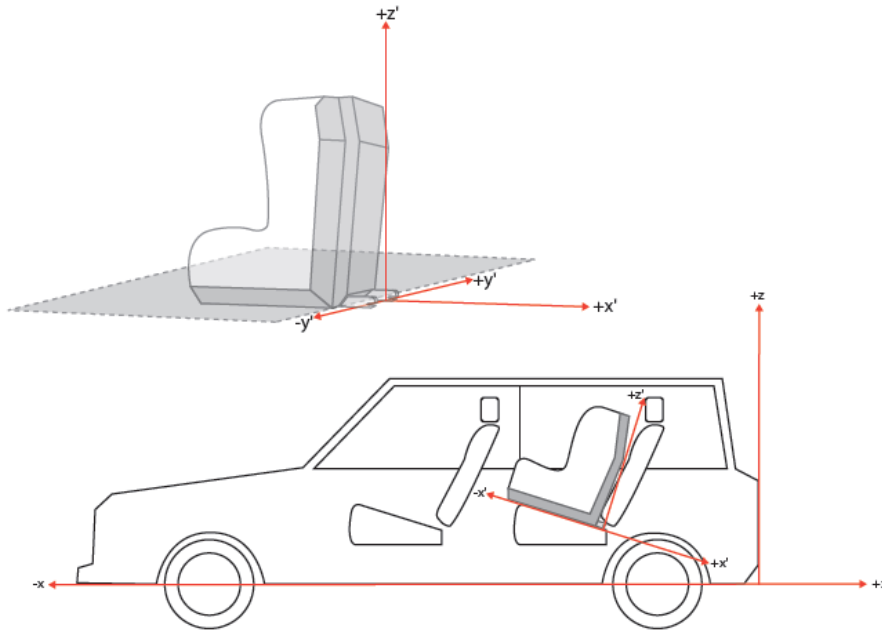

6.3.5.1. Support-leg and support-leg foot geometrical requirements

The support leg, including its attachment to the **Enhanced Child Restraint Systems** and the support-leg foot shall lie completely within the support leg dimension assessment volume (see also Figures 1 and 2 of Annex 19 of this Regulation), which is defined as follows:

- (a) In width by two planes parallel to the $X' - Z'$ plane separated by 200 mm, and centered around the origin; and
- (b) In length by two planes parallel to the $Z' - Y'$ plane and positioned at distances of 585 mm and 695 mm forward of the origin along the X' axis; and
- (c) In height by a plane parallel to the $X' - Y'$ plane, positioned at a distance of 70 mm above **the** origin and **measured** perpendicular to the $X' - Y'$ plane. Rigid, non-adjustable parts shall not extend beyond a plane parallel to the $X' - Y'$ plane, positioned at a distance of 285 mm below the origin and perpendicular to the $X' - Y'$ plane. For parts adjustable in the Z direction there shall be no limitation in height below the level of the CRF bottom surface, providing it is also possible to adjust them to meet the requirements of the support leg dimension assessment volume.

6.3.5.2. Support-leg foot adjustability requirements

The support-leg shall be adjustable in order to ensure that the support-leg foot can be positioned throughout the height range of the support-leg foot assessment volume as specified below (see also Figures 3 and 4 of Annex 19 to this Regulation). Where incremental adjustment is provided, the step between two locked positions shall not exceed 20 mm.

The support leg foot assessment volume is defined as follows:

- (a) In width by two planes parallel to the $X' - Z'$ plane, separated by 200 mm, and centered around the origin; and

- (b) In length by two planes parallel to the Z'-Y' plane and positioned at distances of 585 mm and 695 mm forward of the origin along the X' axis; and
- (c) In height by two planes parallel to the X'-Y' plane positioned at distances of 285 mm and 540 mm below the origin along the X' axis.

It shall be permissible for the support-leg to be adjustable beyond the height limits in the Z' direction, providing that no parts extend beyond the limiting planes in the X' and Y' directions.

6.3.5.3. Support-leg foot dimensions

The dimensions of the support-leg foot shall meet the following requirements:

- (a) Minimum support-leg contact surface shall be 2,500 mm², measured as a projected surface 10 mm above the lower edge of the support-leg foot (see Figure 0(d));
- (b) Minimum outside dimensions shall be 30 mm in the X' and Y' directions, with maximum dimensions being limited by the support-leg foot assessment volume;
- (c) Minimum radius of the edges of the support-leg foot shall be 3.2 mm.

Figure 0(d)

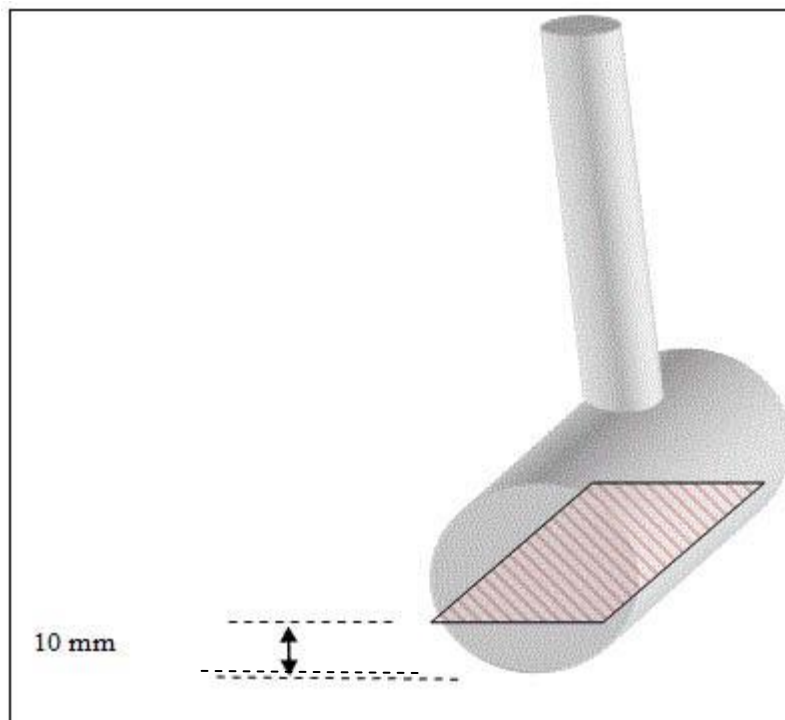

6.3.5.4. Support-leg foot jig

A jig shall be used to check that the support-leg foot meets the requirements defined in paragraph 6.3.5.2. above (see Figure 0(e)). As an alternative a computer simulation shall also be considered satisfactory.

The jig is defined as the ISOFIX CRF corresponding to the size class of the **Enhanced Child Restraint System**. The jig is expanded with two 6 mm diameter ISOFIX low anchorages. The striped box positioned in front of the jig is positioned and sized according paragraph 6.3.5.2. above. The **ECRS** shall have its attachments latched when conducting the assessment.

Figure 0(e)

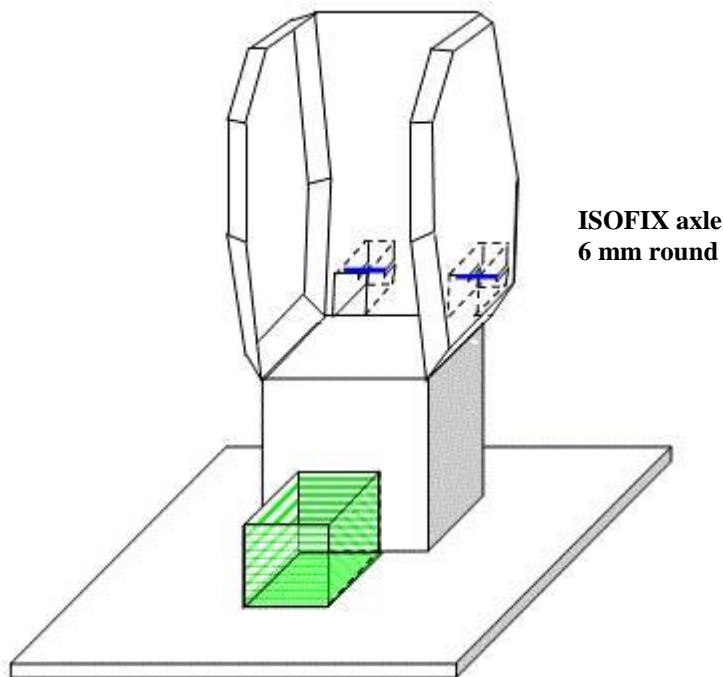

- 6.4. Control of markings
 - 6.4.1. The Technical Service conducting the approval tests shall verify that the markings conform to the requirements of paragraph 4. of this Regulation.
- 6.5. Control of instructions on installation and the instructions for use
 - 6.5.1. The Technical Service conducting the approval tests shall verify that the instructions on installation and the instructions for use conform to paragraph 14. of this Regulation.
- 6.6. Provisions applicable to the assembled **Enhanced** Child Restraint System
 - 6.6.1. Resistance to corrosion
 - 6.6.1.1. A complete **Enhanced** Child Restraint System, or the parts thereof that are liable to corrosion, shall be subject to the corrosion test specified in paragraph 7.1.1. below.
 - 6.6.1.2. After the corrosion test as prescribed in paragraphs 7.1.1.1. and 7.1.1.2. below, no signs of deterioration likely to impair the proper functioning of the **Enhanced** Child Restraint System, and no significant corrosion, shall be visible to the unaided eye of a qualified observer.
 - 6.6.2. Energy absorption
 - 6.6.2.1. For all devices with backrests, the areas defined in Annex 14 to this Regulation, when tested according to Annex 13, shall give a peak acceleration of less than 60g. This requirement applies also to areas of impact shields which are in the head strike area.
 - 6.6.2.2. In the case of **Enhanced** Child Restraint Systems with permanent mechanically attached adjustable head support devices, in which the height of the child harness is directly controlled by the adjustable head support, it is not necessary to demand energy absorbing material in areas as defined in Annex 14, which are not contactable by the dummy's head, i.e. behind the head support.
 - 6.6.3. Overturning
 - 6.6.3.1. The **Enhanced** Child Restraint System shall be tested as prescribed in paragraph 7.1.2.; at no point during the whole test shall the manikin be fully ejected from the device. In addition when the **test bench** is in the upside down position, the dummy's head shall not move more than 300 mm from its original position in a vertical direction relative to the **test bench**.
 - 6.6.4. Dynamic test
 - 6.6.4.1. General: **The dynamic test shall be performed on Enhanced Child Restraint Systems which have not previously been under load and the Enhanced Child Restraint System** shall be subjected to dynamic tests, in accordance with Table 2, in conformity with paragraph 7.1.3. below:

Table 2
Application of different criteria depending of test set up

<i>Frontal impact</i>				<i>Rear impact</i>		<i>Lateral impact</i>	
<i>Test on trolley+ standard seat</i>		<i>Test in car body</i>		<i>Test on trolley+ standard seat</i>	<i>Test in car body</i>	<i>Test on trolley+ standard seat</i>	
Forward facing	Rearward and lateral facing	Forward facing	Rearward and lateral facing	Rearward and lateral facing	Rearward and lateral facing	Forward facing	Rearward and lateral facing

Note 1: Standard seat means ~~test seat~~ or test bench as defined in annex 6.

Note 2: For lateral facing **Enhanced Child Restraint Systems** in lateral impact, if two positions are possible, then the dummy’s head shall be situated near the side door.

- 6.6.4.1.1. i-Size category **Enhanced** Child Restraint Systems shall be tested on the test ~~trolley by means of the test seat bench~~ prescribed in Annex 6, and in conformity with paragraph 7.1.3.1. below.
- 6.6.4.1.2. **Enhanced** Child Restraint Systems of the Specific vehicle categories shall be tested with each vehicle model for which the **Enhanced** Child Restraint System is intended. The Technical Service responsible for conducting the test may reduce the number of vehicle models tested if they do not differ greatly in the aspects listed in paragraph 6.6.4.1.2.3. of this Regulation. The **Enhanced** Child Restraint System may be tested in one of the following ways:
 - 6.6.4.1.2.1. **Enhanced** Child Restraint System according to paragraph 2.7. and in conformity with paragraph 6.3. of this Regulation and which fit in an envelope defined in Regulation No. 16, Annex 17, Appendix 2, on the test ~~trolley by means of the test bench~~ prescribed in Annex 6 and in conformity with paragraph 7.1.3.1. of this Regulation or in a vehicle body shell in conformity with paragraph 7.1.3.2. of this Regulation.
 - 6.6.4.1.2.2. For **Enhanced** Child Restraint System which **are** in conformity with paragraph 6.3. of this Regulation (for example ECRS using no anti-rotation device or using additional anchorages) or do not fit in any envelope defined in Regulation No. 16, Annex 17, Appendix 2 on the test trolley in a vehicle body shell in conformity with paragraph 7.1.3.2. or in a complete vehicle in conformity with paragraph 7.1.3.3. of this Regulation.
 - 6.6.4.1.2.3. Using sufficient parts of the vehicle body shell to be representative of the vehicle structure and impact surfaces. If the **Enhanced** Child Restraint System is intended for use in the rear seat, these shall include the back of the front seat, the rear seat, the floor pan, the B and C pillars and the roof. If the **Enhanced** Child Restraint System is intended for use in the front seat, the parts shall include the dashboard, the A pillars, the windscreen, any levers or knobs installed in the floor or on a console, the front seat, the floor pan and the roof. The Technical Service responsible for conducting the test may permit items to be excluded if they are found to be superfluous. Testing shall be as prescribed in paragraph 7.1.3.2. of this Regulation, except for lateral impact.
- 6.6.4.1.3. ~~The dynamic test shall be performed on Child Restraint Systems which have not previously been under load.~~ **Universal booster category Enhanced**

Child Restraint System shall be tested on the test bench prescribed in Annex 6, and in conformity with paragraph 7.1.3.1. below.

- 6.6.4.1.4. If an "Specific vehicle ISOFIX" **Enhanced** Child Restraint System is installed in the area behind the rearmost forward facing adult seat positions (for example, the luggage area), one test with the largest dummy/dummies, as allowed by the **Enhanced** Child Restraint System, on a complete vehicle as prescribed in paragraph 7.1.3.3. of this Regulation shall be performed. The other tests, including the conformity of production, may be done as prescribed in paragraph 7.1.3.2. of this Regulation, at the request of the manufacturer.
- 6.6.4.1.5. In the case of a "Special Needs Restraint" every dynamic test specified by this Regulation for the range of size specified by the manufacturer shall be performed twice: first, using the primary means of restraint and second, with all restraining devices in use. In these tests, special attention shall be given to the requirements in paragraphs 6.2.1.5. and 6.2.1.6. of this Regulation.
- 6.6.4.1.6. In the case of **an Enhanced** Child Restraint System making use of an anti-rotation device **and / or a shoulder strap positioner**, the dynamic test shall be carried out as follows:
- 6.6.4.1.6.1. With the anti-rotation device **and with the shoulder strap positioner** in use, and
- 6.6.4.1.6.2. without the anti-rotation device **and without the shoulder strap positioner** in use, unless a mechanism is provided to prevent incorrect use of the anti-rotation device **and / or the shoulder strap positioner**.
- 6.6.4.2. During the dynamic tests, no part of the **Enhanced** Child Restraint System affecting the restraint of the occupant shall fully or partially fracture, and no buckle, locking system or displacement system shall release or unlock. The only exception is where such parts or systems are identified as having a load limiting function in the manufacturer's technical description, as defined in paragraph 3.2.1. of this Regulation, and they comply with the following criteria:
- 6.6.4.2.1. Perform as predicted by the manufacturer.
- 6.6.4.2.2. Do not compromise the ability of the **Enhanced** Child Restraint System to protect the occupant.
- 6.6.4.3. Dummy criteria for frontal and rear impact.
- 6.6.4.3.1. Injury assessment criteria for frontal and rear impact as in Table 3.

Table 3

<i>Criterion</i>	<i>Abbreviation</i>	<i>Unit</i>	<i>Q0</i>	<i>Q1</i>	<i>Q1,5</i>	<i>Q3</i>	<i>Q6</i>	<i>Q10</i>
Head performance criterion (only in case of contact during in-vehicle testing)	HPC* (15)		600	600	600	800	800	?
Head acceleration 3 ms	A head 3 ms	g	75	75	75	80	80	?
Upper neck tension Force	Fz	N	For monitoring purpose only**					?

Criterion	Abbreviation	Unit	Q0	Q1	Q1,5	Q3	Q6	Q10
Upper neck flexion moment	My	Nm	For monitoring purpose only***					?
Chest acceleration 3 ms	A chest 3 ms	g	55	55	55	55	55	?
Chest deflection		m m	?	?	?	?	?	?
Abdominal pressure		Bar	?	?	?	?	?	?

* HPC: see Annex 17.

** To be reviewed within 3 years following entry into force of this Regulation.

*** To be reviewed within 3 years following entry into force of this Regulation.

6.6.4.4. Dummy’s head displacement for frontal and rear impact

6.6.4.4.1. **Enhanced** Child Restraint Systems of ~~i-Size~~ **universal** categories:

6.6.4.4.1.1. Forward facing **Enhanced** Child Restraint Systems

Head excursion: No part of the head of the dummy shall pass beyond the planes BA, DA and DE as defined in Figure 1 below **except for booster seats when using the largest dummy Q10 where the value in relation to DA plane is 840 mm and the value in relation to BA plane is 550 mm** This shall be judged up to 300 ms or the moment that the dummy has come to a definitive standstill whatever occurs first.

6.6.4.4.1.1.1. Where a test is conducted in accordance with paragraph 6.6.4.1.6.2. above, a tolerance of +10 per cent shall be applicable to the head excursion value distance between Cr point and plane AB

Figure 1

Arrangement for testing a forward-facing device

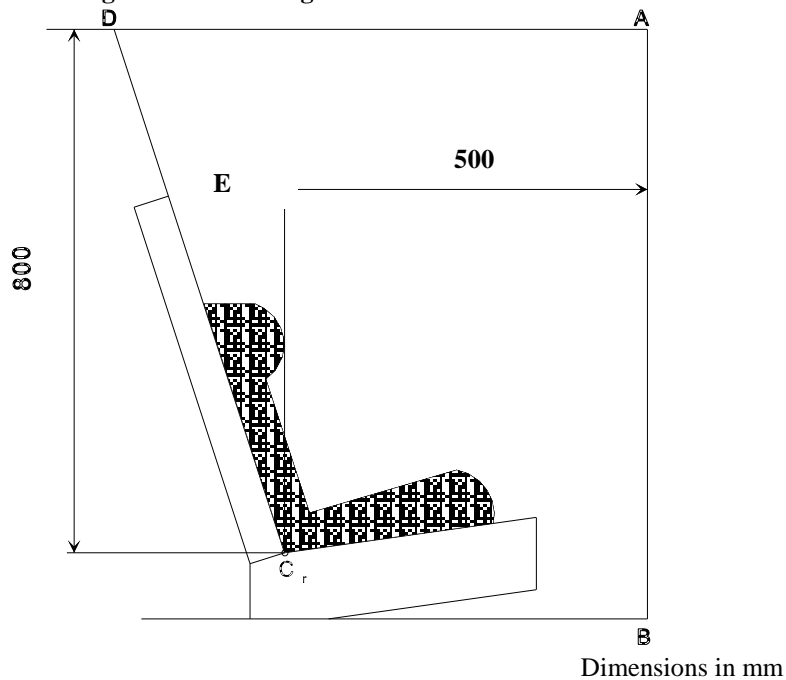

6.6.4.4.1.2. Rearward-facing **Enhanced** Child Restraint Systems and carrycots:

6.6.4.4.1.2.1. Head excursion: no part of the head of the dummy shall pass beyond the planes FD, FG and DE, as shown in Figure 2 below. This shall be judged up to 300 ms or the moment that the dummy has come to a definitive standstill whatever occurs first.

In the case there is a contact of such a **Enhanced** Child Restraint System with the 100 mm diameter bar and all injury assessment and dummy's head displacement criteria are met, there shall be one further dynamic test (front impact) with the heaviest dummy intended for the given range of size indication and without the 100 mm diameter bar; the requirements for this test are that all criteria other than forward displacement shall be met.

Where a test is conducted in accordance with paragraph 6.6.4.1.6.2. above, only the second configuration without 100 mm diameter bar will be considered.

Figure 2

Arrangement for testing a rearward-facing device, not supported by the dashboard

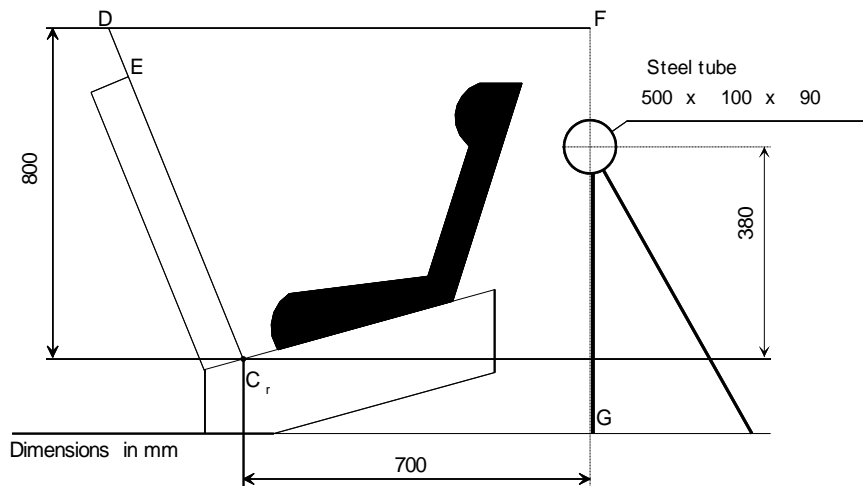

- 6.6.4.4.2. When **Enhanced** Child Restraint Systems of the "Specific vehicle ISOFIX" categories are tested in a complete vehicle or a vehicle body shell, the head performance criterion (HPC) and the Head Acceleration 3 ms shall be used as assessment criteria. Where there is no head contact, these criteria shall be satisfied without measurement, and recorded only as "No Head Contact". After a test, using a complete vehicle, it shall be possible to remove the fully assembled dummy from the **Enhanced** Child Restraint System without the use of mechanical leverage, or the use of tools on the Enhanced Child Restraint System or vehicle structure.
- 6.6.4.4.3 During the dynamic tests, no part of the **Enhanced** Child Restraint System restraining the child in position shall fail. This includes buckles, locking systems and reclining systems, except where identified as a load limiting device. Any load limiting device shall be identified in the manufacturers' technical descriptions as defined in paragraph 3.2.1. of this Regulation.
- 6.6.4.5. Dummy criteria for lateral impact for forward and rearward facing **Enhanced** Child Restraint System.
- 6.6.4.5.1. Main injury assessment criterion — Head containment

During the loading phase of lateral impact testing, up to 80 ms, side protection shall always be positioned at the level at the dummy’s-head centre of gravity perpendicular to the direction of the door intrusion. Head containment will be assessed by the following criteria:

- (a) No head contact with the door panel;
- (b) Head shall not exceed a vertical plane identified by a red line on top of the door (top view camera). This vertical plane is identified by a line on the impacted door as defined in Annex 6, Appendix 3, Figure 1. **This criteria is for monitoring purpose only for tests with Q10 dummy.**

6.6.4.5.2. Additional Injury assessment criteria for lateral impact

Criterion	Abbreviation	Unit	Q0	Q1	Q1,5	Q3	Q6	Q10
Head performance criterion	HPC (15)		600	600	600	800	800	For monitoring purpose only
Head acceleration 3 ms	A head 3 ms	g	75	75	75	80	80	
Upper neck tension force	Fz	N	For monitoring purpose only*					
Upper neck flexion moment	Mx	Nm	For monitoring purpose only**					

* To be reviewed within 3 years following entry into force of this Regulation.

** To be reviewed within 3 years following entry into force of this Regulation.

6.6.5. Resistance to temperature

6.6.5.1. Buckle assemblies, retractors, adjusters and lock-off devices that are liable to be affected by temperature, shall be subject to the temperature test specified in paragraph 7.2.7. below.

6.6.5.2. After the temperature test as prescribed in paragraph 7.2.7.1. below, no signs of deterioration likely to impair the proper functioning of the restraint of the child, shall be visible to the unaided eye of a qualified observer. The dynamic tests should then be performed.

6.7. Provisions applicable to individual components of the restraint

6.7.1. Buckle

6.7.1.1. The buckle shall be so designed as to preclude any possibility of incorrect manipulation. This means, inter/alia, that it shall not be possible for the buckle to be left in a partially closed position; it shall not be possible to exchange the buckle parts inadvertently when the buckle is being locked; the buckle shall only lock when all parts are engaged. Wherever the buckle is in contact with the child, it shall not be narrower than the minimum width of strap as specified in paragraph 6.7.4.1.1. below.. In the case of a "Special Needs Restraint" only the buckle on the primary means of restraint need comply with the requirements of paragraphs 6.7.1.2. to 6.7.1.8. inclusive.

6.7.1.2. The buckle, even when not under tension, shall remain closed whatever its position. It shall be easy to operate and to grasp. It shall be possible to open it by pressure on a button or on a similar device.

The surface to which this pressure shall be applied shall have, in the position of actual unlocking and when projected into a plane perpendicular to the button's initial direction of motion:

- (a) For enclosed devices, an area of not less than 4.5 cm² with a width of not less than 15 mm;
- (b) For non-enclosed devices, an area of 2.5 cm² and a width of not less than 10 mm. The width shall be the smaller of the two dimensions forming the prescribed area and shall be measured rectangular to the direction of movement of the release button.

- 6.7.1.3. The buckle release area shall be coloured red. No other part of the buckle shall be of this colour.
- 6.7.1.4. It shall be possible to release the child from the restraint by a single operation on a single buckle **after release of the shoulder strap positioner, if any**. It is allowed to remove the child together with devices such as infant carrier/carry-cot/carry-cot restraints if the **Enhanced** Child Restraint System can be released by operation of a maximum of two release buttons.
 - 6.7.1.4.1. **Shoulder strap positioner**
If a shoulder strap positioner is provided, it shall be designed so as to prevent incorrect manipulation. It shall not be possible to use the device in a manner which would cause the shoulder straps to twist. It shall be possible to fasten the device in no more than one action. The force required to fasten the device shall not exceed 15 N.
 - 6.7.1.4.2. The shoulder strap positioner shall be easy to operate and to grasp. It shall be possible to open it in one simple action, but it shall be difficult for the child occupant to manipulate the release mechanism. The force required to release the device shall not exceed 15 N.
 - 6.7.1.4.3. The shoulder strap positioner shall not exceed 60 mm in height.
- 6.7.1.5. Opening of the buckle shall enable the child to be removed independently of the "chair", "chair support" or "impact shield", if fitted, and if the device includes a crotch strap the crotch strap shall be released by operation of the same buckle.
- 6.7.1.6. The buckle shall be capable of withstanding the temperature test operation requirements given in paragraph 7.2.7. below and repeated operation, and shall, before the dynamic test prescribed in paragraph 7.1.3. below undergo a test comprising 5,000 ± 5 opening and closing cycles under normal conditions for use.
- 6.7.1.7. The buckle shall be subjected to the following tests of opening:
 - 6.7.1.7.1. **Test under load**
 - 6.7.1.7.1.1. A **Enhanced** Child Restraint System having already undergone the dynamic test prescribed in paragraph 7.1.3. below shall be used for this test.
 - 6.7.1.7.1.2. The force required to open the buckle in the test prescribed in paragraph 7.2.1.1. below shall not exceed 80 N.
 - 6.7.1.7.2. **No-load test**

- 6.7.1.7.2.1. A buckle which has not previously been subjected to a load shall be used for this test. The force needed to open the buckle when it is not under load shall be in the range of 40–80 N in the tests prescribed in paragraph 7.2.1.2. below
- 6.7.1.8. Strength
 - 6.7.1.8.1. During the test in accordance with paragraph 7.2.1.3.2. below no part of the buckle or the adjacent straps or adjusters shall break or be detached.
 - 6.7.1.8.2. Depending of the mass limit declared by the manufacturer, a harness buckle shall withstand:
 - 6.7.1.8.2.1. 4 kN, if the mass limit is less or equal to 13 kg;
 - 6.7.1.8.2.2. 10 kN, if the mass limit is greater than 13 kg.
 - 6.7.1.8.3. The Type Approval Authority may dispense with the buckle strength test if information already available renders the test superfluous.
- 6.7.2. Adjusting device
 - 6.7.2.1. The range of adjustment shall be sufficient to permit correct adjustment of the **Enhanced** Child Restraint System with all size for which the device is intended and to permit satisfactory installation in all i-Size compatible vehicles.
 - 6.7.2.2. All adjusting devices shall be of the quick adjuster type.
 - 6.7.2.3. Devices of the quick adjuster type shall be easy to reach when the **Enhanced** Child Restraint System is correctly installed and the child or dummy is in position.
 - 6.7.2.4. A device of the quick adjuster type shall be easily adjustable to the child's physique. In particular, in a test performed in accordance with paragraph 7.2.2.1. below, the force required to operate a manual adjusting device shall not exceed 50 N.
 - 6.7.2.5. Two samples of the **Enhanced** Child Restraint System adjusting devices shall be tested as prescribed by the temperature test operation requirements given in paragraph 7.2.7.1. and paragraph 7.2.3. below.
 - 6.7.2.5.1. The amount of strap slip shall not exceed 25 mm for one adjusting device or 40 mm for all adjusting devices.
 - 6.7.2.6. The device shall not break or become detached when tested as prescribed in paragraph 7.2.2.1. below.
 - 6.7.2.7. An adjuster mounted directly on the **Enhanced** Child Restraint System shall be capable of withstanding repeated operation and shall, before the dynamic test prescribed in paragraph 7.1.3. undergo a test comprising $5,000 \pm 5$ cycles as specified in paragraph 7.2.3.
- 6.7.3. Retractors
 - 6.7.3.1. Automatically-locking retractors
 - 6.7.3.1.1. The strap equipped with an automatically-locking retractor shall not unwind by more than 30 mm between locking positions of the retractor. After a rearward movement of the wearer the strap shall either remain in its initial position or return to that position automatically on subsequent forward movement of the wearer.

- 6.7.3.1.2. If the retractor is part of a lap ~~belt~~ **strap**, the retracting force of the strap shall be not less than 7 N as measured in the free length between the dummy and the retractor as prescribed in paragraph 7.2.4.1. below. If the retractor is part of a chest restraint, the retracting force of the strap shall be not less than 2 N or more than 7 N as similarly measured. If the strap passes through a guide or pulley, the retracting force shall be measured in the free length between the dummy and the guide or pulley. If the assembly incorporates a device, manually or automatically operated, that prevents the strap from being completely retracted, that device shall not be in operation when these measurements are effected.
- 6.7.3.1.3. The strap shall be repeatedly withdrawn from the retractor and allowed to retract, in the conditions prescribed in paragraph 7.2.4.2. below, until 5,000 cycles have been completed. The retractor shall then be subjected to the temperature test operation requirements given in paragraph 7.2.7.1. and corrosion test described in paragraph 7.1.1. below and the dust-resistance test described in paragraph 7.2.4.5. below. It shall then satisfactorily complete a further 5,000 cycles of withdrawal and retraction. After the above tests the retractor shall continue to operate correctly and to meet the requirements of paragraphs 6.7.3.1.1. and 6.7.3.1.2. above.
- 6.7.3.2. Emergency-locking retractors
- 6.7.3.2.1. An emergency-locking retractor shall when tested as prescribed in paragraph 7.2.4.3. satisfy the conditions below:
- 6.7.3.2.1.1. It shall be locked when the deceleration of the vehicle reaches 0.45 g;
- 6.7.3.2.1.2. It shall not lock for strap accelerations of less than 0.8 g as measured in the axis of strap extraction;
- 6.7.3.2.1.3. It shall not lock when its sensing device is tilted by not more than 12° in any direction from the installation position specified by its manufacturer;
- 6.7.3.2.1.4. It shall lock when its sensing device is tilted by more than 27° in any direction from the installation position specified by its manufacturer.
- 6.7.3.2.2. Where the operation of a retractor depends on an external signal or power source, the design shall ensure that the retractor locks automatically upon failure or interruption of that signal or power source.
- 6.7.3.2.3. A multiple-sensitivity emergency-locking retractor shall meet the requirements set out above. In addition, if one of the sensitivity factors relates to strap extraction, locking shall have occurred at a strap acceleration of 1.5 g as measured in the axis of strap extraction.
- 6.7.3.2.4. In the tests referred to in paragraphs 6.7.3.2.1.1. and 6.7.3.2.3. above, the amount of strap extraction occurring before the retractor locks shall not exceed 50 mm, starting at the length of unwinding specified in paragraph 7.2.4.3.1. below. In the test referred to in paragraph 6.7.3.2.1.2. above, locking shall not occur during the 50 mm of strap extraction starting at the length of unwinding specified in paragraph 7.2.4.3.1. below.
- 6.7.3.2.5. If the retractor is part of a lap ~~belt~~ **strap**, the retracting force of the strap shall be not less than 7 N as measured in the free length between the dummy and the retractor as prescribed in paragraph 7.2.4.1. below. If the retractor is part of a chest restraint, the retracting force of the strap shall be not less than 2 N or more than 7 N as similarly measured. If the strap passes through a guide or pulley, the retracting force shall be measured in the free length between the dummy and the guide or pulley. If the assembly incorporates a device,

manually or automatically operated, that prevents the strap from being completely retracted, that device shall not be in operation when these measurements are effected.

- 6.7.3.2.6. The strap shall be repeatedly withdrawn from the retractor and allowed to retract, in the conditions prescribed in paragraph 7.2.4.2., until 40,000 cycles have been completed. The retractor shall then be subjected to the temperature test operation requirements given in paragraph 7.2.7 and corrosion test described in paragraph 7.1.1. and to the dust-resistance test described in paragraph 7.2.4.5.
- 6.7.4. Straps
- 6.7.4.1. Width
- 6.7.4.1.1. The minimum width at the child-restraint straps which contact the dummy shall be 25 mm. These dimensions shall be measured during the strap strength test prescribed in paragraph 7.2.5.1. below, without stopping the machine and under a load equal to 75 per cent of the breaking load of the strap.
- 6.7.4.2. Strength after room conditioning
- 6.7.4.2.1. On two sample straps conditioned as prescribed in paragraph 7.2.5.2.1., the breaking load of the strap shall be determined as prescribed in paragraph 7.2.5.1.2. below.
- 6.7.4.2.2. The difference between the breaking loads of the two samples shall not exceed 10 per cent of the greater of the two breaking loads measured.
- 6.7.4.3. Strength after special conditioning
- 6.7.4.3.1. On two straps conditioned as prescribed in one of the provisions of paragraph 7.2.5.2. below (except para. 7.2.5.2.1. below), the breaking load of the strap shall be not less than 75 per cent of the average of the loads determined in the test referred to in paragraph 7.2.5.1. below.
- 6.7.4.3.2. In addition, the breaking load shall be not less than 3.6 kN for the restraints of i-Size **Enhanced** Child Restraint Systems.
- 6.7.4.3.3. The Type Approval Authority may dispense with one or more of these tests if the composition of the material used, or information already available, renders the test or tests superfluous.
- 6.7.4.3.4. The abrasion conditioning procedure of type 1 defined in paragraph 7.2.5.2.6. below shall only be performed when the microslip test defined in paragraph 7.2.3. below gives a result above 50 per cent of the limit prescribed in paragraph 6.7.2.5.1. above.
- 6.7.4.4. It shall not be possible to pull the complete strap through any adjusters, buckles or anchoring points.
- 6.7.5. ISOFIX attachment specifications
- "ISOFIX attachments" and latching indicators shall be capable of withstanding repeated operations and shall, before the dynamic test prescribed in paragraph 7.1.3. below, undergo a test comprising $2,000 \pm 5$ opening and closing cycles under normal conditions of use.
- 6.7.5.1. ISOFIX attachments and latching indicators shall be capable of withstanding repeated operations and shall, before the dynamic test prescribed in

paragraph 7.1.3., undergo a test comprising 2000 ± 5 opening and closing cycles under normal conditions of use."

- 6.7.5.2. ISOFIX attachments shall have a locking mechanism which complies with the requirements specified in (a) or (b) as follows:
- (a) Release of the locking mechanism of the complete seat, shall require two consecutive actions, the first of which should be maintained while the second is carried out; or
 - (b) The ISOFIX attachment opening force shall be at least 50 N when tested as prescribed in paragraph 7.2.8. below.
- 6.8. Classification
- 6.8.1. **Enhanced** Child Restraint Systems may cover any size range provided that the requirements for the whole range are fulfilled.

7. Tests

- 7.1. Tests of the assembled **Enhanced** Child Restraint System
- 7.1.1. Corrosion
- 7.1.1.1. The metal items of the **Enhanced** Child Restraint System shall be positioned in a test chamber as prescribed in Annex 4. In the case of a **Enhanced** Child Restraint System incorporating a retractor, the strap shall be unwound to full length less 100 ± 3 mm. Except for short interruptions that may be necessary, for example, to check and replenish the salt solution, the exposure test shall proceed continuously for a period of 50 ± 0.5 hours.
- 7.1.1.2. On completion of the exposure test the metal items of the **Enhanced** Child Restraint System shall be gently washed, or dipped, in clean running water with a temperature not higher than $38 \text{ }^\circ\text{C}$ to remove any salt deposit that may have formed and then allowed to dry at room temperature of $18 \text{ }^\circ\text{C}$ to $25 \text{ }^\circ\text{C}$ for 24 ± 1 hours before inspection in accordance with paragraph 6.6.1.2. above.
- 7.1.2. Overturning
- 7.1.2.1. ~~The dummy shall be equipped with the load application device as described in Annex 21 and placed in the restraints installed in accordance with this Regulation and taking into account the manufacturer's instructions and with the standard slack as specified in paragraph 7.1.3.5., applied for all systems identically. The manikin shall be equipped with either of the load application devices as appropriate and described in Annex 21. Place the manikin in the restraints installed in accordance with this Regulation and taking into account the manufacturer's instructions and with the standard slack as specified in paragraph 7.1.3.5. below, applied for all systems identically.~~
- 7.1.2.2. The restraint shall be fastened to the test bench or vehicle seat. The whole **Enhanced** Child Restraint System shall be rotated around a horizontal axis contained in the median longitudinal plane of the **Enhanced** Child Restraint System through an angle of $540^\circ \pm 5^\circ$ at a speed of 2-5 degrees/second and stopped in this position. For the purposes of this test, devices intended for use in specific cars may be attached to the test bench described in Annex 6.

- 7.1.2.3. At this static inverted position, a mass equivalent to four times that of the dummy shall be applied vertically downwards in a plane perpendicular to the axis of rotation in addition to the dummy utilizing the load application device described in Annex 21. The load shall be applied in a gradual controlled manner at a rate not exceeding gravitational acceleration or 400mm/min. Maintain the prescribed maximum load for a duration of 30 -0/+5 seconds.
- 7.1.2.4. Remove the load at a rate not exceeding 400 mm/min and measure displacement.
- 7.1.2.5. Rotate the whole seat for 180° to return to the starting position
- 7.1.2.6. This test cycle shall be carried out again rotating in the reverse direction. With the rotational axis in the horizontal plane and at 90° to that of the two earlier tests, the procedure shall be repeated in the two directions of rotation.
- 7.1.2.7. These tests shall be carried out using both the smallest and the largest appropriate dummy of the size range for which the restraining device is intended. Any adjustment of the dummy or **Enhanced** Child Restraint Systems during the complete test cycle is not allowed.
- 7.1.3. Dynamic testing for frontal, rear and lateral impact:
- (a) Frontal impact test shall be performed on i-Size (Integral Universal ISOFIX **Enhanced** Child Restraint Systems) ~~and~~ , Specific vehicle ISOFIX **Enhanced** Child Restraint Systems **and to non-integral Enhanced Child Restraint Systems Universal Boosters and specific to vehicle Booster;**
 - (b) Rear impact test shall be performed on i-Size and Specific Vehicle ISOFIX Rearward facing **Enhanced** Child Restraint Systems;
 - (c) Lateral impact test are performed only on the test bench for i-Size Integral Universal ISOFIX **Enhanced** Child Restraint Systems, Specific vehicle ISOFIX **and for non-integral Enhanced Child Restraint Systems Universal Boosters seat and specific to vehicle Booster seat.**
- 7.1.3.1. Tests using the trolley and test bench
- 7.1.3.1.1. Frontal and rear impact tests
- 7.1.3.1.1.1. The trolley and test bench used in the dynamic test shall meet the requirements of Annex 6 to this Regulation.
- 7.1.3.1.1.2. The trolley shall remain horizontal throughout deceleration or acceleration.
- 7.1.3.1.1.3. The test bench shall be rotated 180° when testing in compliance with the requirements of the rear impact test.
- 7.1.3.1.1.4. When testing a rearward-facing **Enhanced** Child Restraint System intended for use in the front seating position, the vehicle facia shall be represented by a rigid bar attached to the trolley in such a way that all the energy absorption takes place in the **Enhanced** Child Restraint System.
- 7.1.3.1.1.5. Deceleration or acceleration devices
- The applicant shall choose to use one of the two following devices:
- 7.1.3.1.1.5.1. Deceleration test device:

The deceleration of the trolley shall be achieved by using the apparatus prescribed in Annex 6 to this Regulation or any other device giving equivalent results. This apparatus shall be capable of the performance specified in paragraph 7.1.3.4. below and hereafter specified:

Calibration procedure:

The deceleration curve of the trolley, in the case of **Enhanced** Child Restraint System tests performed in accordance with paragraph 7.1.3.1. above, ballasted with inert masses up to 55 kg in order to reproduce one occupied **Enhanced** Child Restraint System, and in the case of **Enhanced** Child Restraint System tests in a vehicle body shell performed in accordance with paragraph 7.1.3.2. below, where the trolley is ballasted with the vehicle structure and inert masses up to (x times) 55 kg reproducing the number of (x) occupied **Enhanced** Child Restraint Systems, shall remain, in the case of frontal impact, within the hatched area of the graph in Annex 7, Appendix 1 to this Regulation, and, in the case of rear impact, within the hatched area of the graph in Annex 7, Appendix 2 to this Regulation.

During calibration of the stopping device, the stopping distance shall be 650 ± 30 mm for frontal impact, and 275 ± 20 mm for rear impact.

Dynamic testing conditions during testing:

For frontal and rear impact the deceleration shall be achieved with the apparatus calibrated as stated above, however:

- (a) The deceleration curve shall not have a more than 3 ms time duration exceedance of the lower borders of the performance requirements;
- (b) If the tests above were performed at a higher speed and/or the deceleration curve has exceeded the upper level of the hatched area and the **Enhanced** Child Restraint System meets the requirements, the test shall be considered satisfactory.

7.1.3.1.1.5.2. Acceleration test device

Dynamic testing conditions:

For frontal impact, the trolley shall be so propelled that, during the test, its total velocity change ΔV is $52 + 0 - 2$ km/h and its acceleration curve is within the hatched area of the graph in Annex 7, Appendix 1 and stay above the segment defined by the coordinates (5 g, 10 ms) and (9 g, 20 ms). The start of the impact (T0) is defined, according to ISO 17 373 for a level of acceleration of 0.5 g.

For rear impact, the trolley shall be so propelled that, during the test, its total velocity change ΔV is $32 + 2 - 0$ km/h and its acceleration curve is within the hatched area of the graph in Annex 7, Appendix 2 and stay above the segment defined by the coordinates (5 g, 5 ms) and (10 g, 10 ms). The start of the impact (T0) is defined, according to ISO 17 373 for a level of acceleration of 0.5 g.

Despite the fulfilment of the above requirements, the Technical Service shall use a mass of trolley (equipped with its test bench), as specified in paragraph 1. of Annex 6, superior to 380 kg.

However, if the tests above were performed at a higher speed and/or the acceleration curve has exceeded the upper level of the hatched area and the

Enhanced Child Restraint System meets the requirements, the test shall be considered satisfactory.

- 7.1.3.1.1.6. The following measurements shall be made:
 - 7.1.3.1.1.6.1. The trolley speed immediately before impact (only for deceleration sleds, needed for stopping distance calculation);
 - 7.1.3.1.1.6.2. The stopping distance (only for deceleration sleds), which may be calculated by double integration of the recorded sled deceleration;
 - 7.1.3.1.1.6.3. The displacement of the dummy's head in the vertical and horizontal direction of the tests with all Q-dummies necessary for the given i-Size indication for at least the first 300 ms;
 - 7.1.3.1.1.6.4. The parameters required to perform the injury assessment against the criteria as mentioned in paragraph 6.6.4.3.1. above for at least the first 300 ms;
 - 7.1.3.1.1.6.5. The trolley acceleration or deceleration for at least the first 300 ms.
- 7.1.3.1.1.7. After impact, the **Enhanced** Child Restraint System shall be inspected visually, without opening the buckle, to determine whether there has been any failure or breakage.
- 7.1.3.1.2. Rear impact
 - 7.1.3.1.2.1. The **test bench** shall be rotated 180° when testing its compliance with the requirements of the rear impact test.
 - 7.1.3.1.2.2. When testing a rearward-facing **Enhanced Child Restraint System** intended for use in the front seating position, the vehicle facia shall be represented by a rigid bar attached to the trolley in such a way that all the energy absorption takes place in the **Enhanced Child Restraint System**.
 - 7.1.3.1.2.3. The deceleration conditions shall satisfy the requirements of Annex 7, Appendix 2.
The acceleration conditions shall satisfy the requirements of Annex 7, Appendix 2.
 - 7.1.3.1.2.4. The measurements to be made shall be similar to those listed in paragraphs 7.1.3.1.1.4. to 7.1.3.1.1.5. above.
- 7.1.3.1.3. Lateral impact
 - 7.1.3.1.3.1. The test bench shall be rotated 90° when testing in compliance with the requirements of the lateral impact test.
 - 7.1.3.1.3.2. The lower ISOFIX anchorages should be movable in the Y direction to avoid damage of the attachments and test equipment. The ISOFIX anchorages shall be fixed to a sliding system allowing a movement of 200 mm - 0 mm +50 mm.
 - 7.1.3.1.3.3. The lateral impact loading to the **ECRS** shall be generated by a door panel as defined in Annex 6, Appendix 3. The surface of the panel shall be covered with padding as specified in Annex 6, Appendix 3.
 - 7.1.3.1.3.4. The test rig shall reproduce a relative velocity between the door panel and the test bench in compliance with Annex 7, Appendix 3. The maximum intrusion depth of the door panel is defined in Annex 6, Appendix 3. The relative velocity between the door panel and the test bench shall not be affected by contact with the **ECRS** and shall remain within the corridor defined in

Annex 7, Appendix 3. In a test where the door is stationary at time t_0 , the door shall be fixed and the dummy's ground velocity at t_0 shall be between 6.375 m/s and 7.25 m/s. In a test where the door is moving at t_0 , the door's ground velocity shall remain within the corridor defined in Annex 7, Appendix 3 at least until its intrusion reaches its maximum, and the dummy shall be stationary at t_0 .

- 7.1.3.1.3.5. The ECRS shall be tested in its most upright position.
- 7.1.3.1.3.6. At time t_0 defined Annex 7, Appendix 3, the dummy shall be in its initial position as defined in paragraph 7.1.3.5.2.1. below.
- 7.1.3.2. Test on trolley and vehicle body shell
 - 7.1.3.2.1. For frontal impact tests
 - 7.1.3.2.1.1. The method used to secure the vehicle during the test shall not be such as to strengthen the anchorages of the vehicle seats, adult safety belts and any additional anchorages required to secure the **Enhanced Child Restraint System** or to lessen the normal deformation of the structure. No part of the vehicle shall be present which, by limiting the movement of the dummy, would reduce the load imposed on the **Enhanced Child Restraint System** during the test. The parts of the structure eliminated may be replaced by parts of equivalent strength, provided they do not hinder the movement of the dummy.
 - 7.1.3.2.1.2. A securing device shall be regarded as satisfactory if it produces no effect on an area extending over the whole width of the structure and if the vehicle or structure is blocked or fixed in front at a distance of not less than 500 mm from the anchorage of the restraint system. At the rear the structure shall be secured at a sufficient distance behind the anchorages to ensure that all requirements of paragraph 7.1.3.2.1.1. above are fulfilled.
 - 7.1.3.2.1.3. The vehicle seat and **Enhanced Child Restraint System** shall be fitted and placed in a position chosen by the Technical Service conducting the approval tests to give the most adverse conditions in respect of strength, compatible with installation of the dummy in the vehicle. The position of the vehicle seat-back and **Enhanced Child Restraint System** shall be stated in the report. The vehicle seat-back, if adjustable for inclination, shall be locked as specified by the manufacturer or, in the absence of any specification, at an actual seat-back angle as near as possible to 25°.
 - 7.1.3.2.1.4. Unless the instructions for fitting and use require otherwise, the front seat shall be placed in the most forward normally used position for **Enhanced Child Restraints System** intended for use in the front seating position, and in the rearmost normally used position for **Enhanced Child Restraints System** intended for use in the rear seating position.
 - 7.1.3.2.1.5. The deceleration conditions shall satisfy the requirements of paragraph 7.1.3.4. below. The test bench will be the seat of the actual vehicle.
 - 7.1.3.2.1.6. The following measurements shall be made:
 - 7.1.3.2.1.6.1. The trolley speed immediately before impact (only for deceleration sleds, needed for stopping distance calculation);
 - 7.1.3.2.1.6.2. The stopping distance (only for deceleration sleds), which may be calculated by double integration of the recorded sled deceleration;
 - 7.1.3.2.1.6.3. Any contact of the dummy's head with the interior of the vehicle body shell;

- 7.1.3.2.1.6.4. The parameters required to perform the injury assessment against the criteria as mentioned in paragraph 6.6.4.3.1. above for at least the first 300 ms;
- 7.1.3.2.1.6.5. The trolley and vehicle body shell acceleration or deceleration for at least the first 300 ms.
- 7.1.3.2.1.7. After impact, the **Enhanced Child Restraint System** shall be inspected visually, without opening the buckle, to determine whether there has been any failure.
- 7.1.3.2.2. For rear impact tests
 - 7.1.3.2.2.1. The vehicle body shell shall be rotated 180° on the test trolley.
 - 7.1.3.2.2.2. Same requirements as for frontal impact (paras. 7.1.3.2.1.1. to 7.1.3.2.1.5. above) shall apply.
- 7.1.3.3. When testing with a complete vehicle
 - 7.1.3.3.1. The deceleration conditions shall satisfy the requirements of paragraph 7.1.3.4. below.
 - 7.1.3.3.2. For frontal impact tests the procedure shall be that set out in Annex 9 to this Regulation.
 - 7.1.3.3.3. For rear impact tests the procedure shall be that set out in Annex 10 to this Regulation.
 - 7.1.3.3.4. The following measurements shall be made:
 - 7.1.3.3.4.1. The speed of the vehicle/impactor immediately before impact (only for deceleration sleds, needed for stopping distance calculation);
 - 7.1.3.3.4.2. Any contact of the dummy's head with the interior of the vehicle;
 - 7.1.3.3.4.3. The parameters required to perform the injury assessment against the criteria as mentioned in paragraph 6.6.4.3.1. above for at least the first 300 ms.
 - 7.1.3.3.5. The front seats, if adjustable for inclination, shall be locked as specified by the manufacturer or, in the absence of any specification, at an actual seat-back angle as near as possible to 25°.
 - 7.1.3.3.6. After impact, the **Enhanced Child Restraint System** shall be inspected visually, without opening the buckle, to determine whether there has been any failure or breakage.

7.1.3.4. The conditions for dynamic test are summarized in Table 4:

Table 4

Test	Restraint	Frontal impact			Rear Impact			Lateral Impact		
		Speed (km/h)	Test Pulse No.	Stopping distance during test (mm)	Speed (km/h)	Test Pulse No.	Stopping distance during test (mm)	Speed (m/s)	Test Pulse No.	Stopping distance during test (mm) Maximum Intrusion
Trolley with test bench	Forward facing	50+0 -2	1	650 +/- 50	N.A.	N.A.	N.A.	7 +0.25 -0.625	3	250 +/- 50
	Rearward facing	50+0 -2	1	650 +/- 50	30+2 -0	2	275 +/-25	7 +0.25 -0.625	3	250 +/- 50
	Lateral facing	50+0 -2	1	650 +/- 50	30+2 -0	2	275 +/-25	7 +0.25 -0.625	3	250 +/- 50

Legend :

Test Pulse No. 1 - As prescribed in Annex 7 / Appendix 1 – Frontal impact

Test Pulse No. 2 - As prescribed in Annex 7 / Appendix 2 – Rear impact

Test Pulse No. 3 - As prescribed in Annex 7 / Appendix 3 – Lateral impact

N.A. : Not applicable

7.1.3.5. Dynamic test dummies

7.1.3.5.1. The **Enhanced** Child Restraint System shall be tested using the dummies prescribed in Annex 8 to this Regulation.

7.1.3.5.2. Installation for frontal, rear **and lateral** impacts.

7.1.3.5.2.1. Installation of a ~~an~~ **Integral Universal ISOFIX Enhanced** Child Restraint Systems (**i-Size**), or **Integral "Specific vehicle Isofix"** **Enhanced** Child Restraint Systems on the test bench.

The unoccupied ISOFIX **Enhanced** Child Restraint System shall be attached to the ISOFIX anchorage system.

Securing the ISOFIX attachments to the ISOFIX lower anchorages shall be permitted to draw the unoccupied **Enhanced** Child Restraint System towards those anchorages.

An additional force of 135 +/- 15N shall be applied in a plane parallel to the surface of the test seat cushion. The force shall be applied along the centre line of the **Enhanced** Child Restraint System and at a height no more than 100 mm above the cushion.

If present, the top tether shall be adjusted to achieve a tension load of 50 +/- 5N. Alternatively, and if present, the support-leg shall be adjusted according to the **Enhanced** Child Restraint System manufacturer's instructions.

The **Enhanced** Child Restraint System centre line shall be aligned with the centre line of the test bench.

The dummy shall be placed in the **Enhanced** Child Restraint System separate from the seat-back of the chair by a flexible spacer. The spacer shall be 2.5 cm thick and 6 cm wide. It shall have length equal to the shoulder height less the thigh height, both in the sitting position and relevant to the dummy size being tested. The resulting ~~length~~ **height** of the spacer is listed in the table below for

the different dummy sizes. The board should follow as closely as possible the curvature of the chair and its lower end should be at the height of the dummy's hip joint.

	<i>Q0</i>	<i>Q1</i>	<i>Q1.5</i>	<i>Q3</i>	<i>Q6</i>	<i>Q10</i> (design targets)
	Dimensions in mm					
Height of spacer device for positioning of dummy		229 ± 2	237 ± 2	250 ± 2	270 ± 2	359 ± 2

Adjust the ECRS belt in accordance with the manufacturer's instructions, but to a tension of 250 ± 25 N above the adjuster force, with a deflection angle of the strap at the adjuster of 45 ± 5°, or alternatively, the angle prescribed by the manufacturer.

The spacer shall then be removed and the dummy pushed towards to the seat back. Distribute the slack evenly throughout the harness.

The longitudinal plane passing through the centre line of the dummy shall be set midway between the two lower ECRS belt anchorages, however note shall also be taken of paragraph 7.1.3.2.1.3. above.

7.1.3.5.2.2. Installation of a non-integral Enhanced Child Restraint Systems "Universal Booster" or "Specific to vehicle Booster" on the test bench.

The unoccupied Booster shall be placed on the test bench.

If present and tested, securing the ISOFIX attachments to the ISOFIX lower anchorages shall be permitted to draw the unoccupied Enhanced Child Restraint System towards those anchorages. An additional force of 135 +/-15N shall be applied in a plane parallel to the surface of the test seat cushion. The force shall be applied along the centre line of the Enhanced Child Restraint System and at a height no more than 100mm above the cushion

The dummy shall be placed in the Enhanced Child Restraint System.

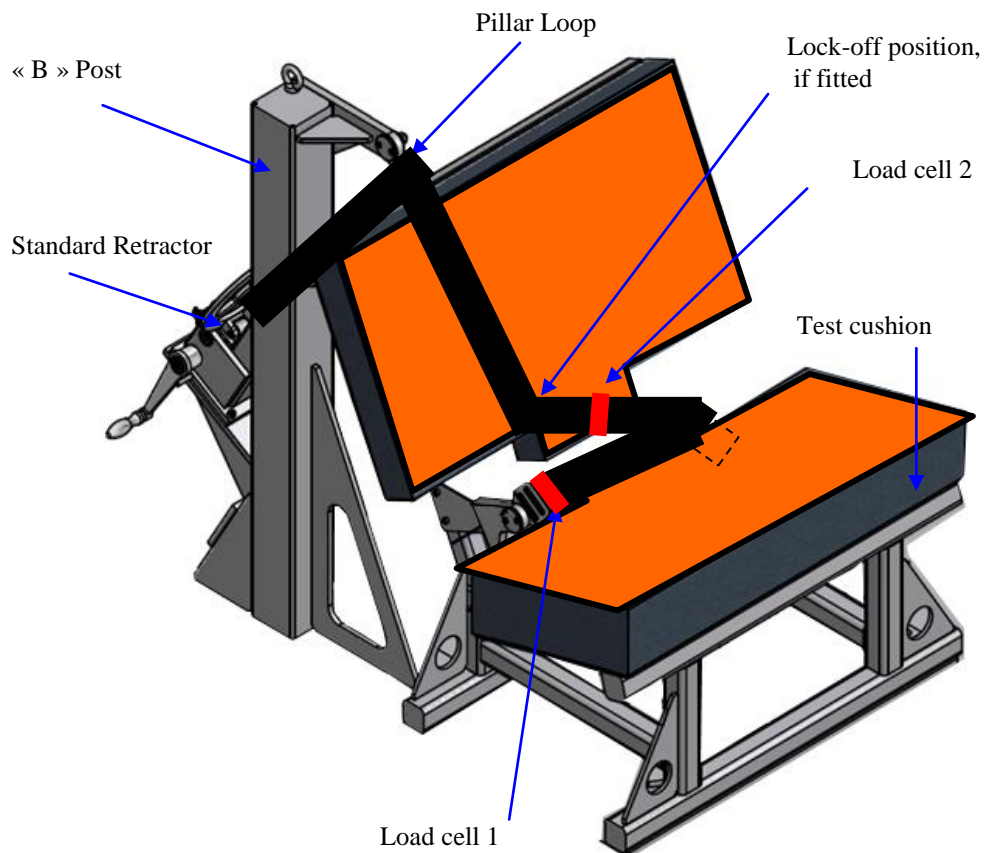

Fit load cell 1 to the outboard position as shown above. Install the Enhanced Child Restraint System into the correct position. If a lock-off device is fitted to the Enhanced Child Restraint System and acts upon the diagonal belt, place load cell 2 at a convenient position behind the Enhanced Child Restraint System between the lock-off device and the buckle as shown above. If no lock-off device is fitted or if the lock-off device is fitted at the buckle, position load cell at a convenient position between the pillar loop and the Enhanced Child Restraint System.

Adjust the lap portion of the reference belt to achieve, a tension load of $50\text{N} \pm 5\text{N}$ at load cell 1. Make a chalk mark on the webbing where it passes through the simulated buckle. While maintaining the belt at this position adjust the diagonal to achieve a tension of $50\text{N} \pm 5\text{N}$ at load cell 2 by either locking the webbing at the Enhanced Child Restraint System webbing locker or by pulling the belt close to the standard retractor.

Extract all webbing from the retractor spool and rewind with a tension in the belt of $4 + 3\text{N}$ between the retractor and pillar loop to drop to the retractor tension. The spool shall be locked before the dynamic test. Conduct the dynamic crash test.

7.1.3.5.2.3. After installation

After installation, the dummy position shall be adjusted so that:

The dummy centre line and the **Enhanced** Child Restraint System centre line shall be aligned exactly with the centre line of the test bench.

The arms of the dummy shall be positioned symmetrically. Elbows shall be positioned in such a way that the upper arms are closely aligned with the sternum.

Hands shall be positioned on the thighs.

Legs shall be positioned parallel to one another or at least symmetrically.

For lateral impact, positive measures shall be taken to ensure the stability of the dummy is maintained until t_0 and this shall be confirmed using video analysis. Any means used to stabilise the dummy before t_0 shall not influence the dummy kinematics after t_0 .

Because the foam of the test bench seat cushion will compress after installation of the **Enhanced** Child Restraint System, the dynamic test shall be conducted no more than 10 minutes after installation.

To allow the test bench seat cushion to recover, the minimum period between two tests using the same test bench seat cushion shall be 20 minutes.

Example for arm alignment:

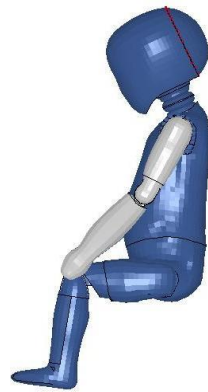

Arms are aligned with sternum

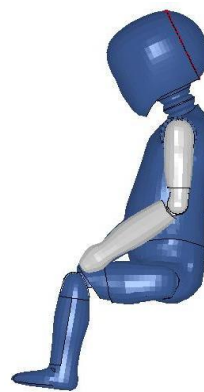

Arms are not aligned with sternum

7.1.3.6 † Size indication

The dynamic tests shall be conducted with the largest dummy and the smallest dummy as defined in the following tables according to the size range indicated by the manufacturer for the **Enhanced** Child Restraint System.

Table 6
Selection criteria for the dummy according to the range

<i>Size range indication</i>	≤ 60	$60 < x \leq 75$	$75 < x \leq 87$	$87 < x \leq 105$	$105 < x \leq 125$	> 125
Dummy	Q0	Q1	Q1.5	Q3	Q6	Q10 ³

Where the **Enhanced** Child Restraint System requires substantial modification for different sizes (e.g., convertible Enhanced Child Restraint

³ For lateral impact, Q6 dummy could be used for a size range up to 135 cm

System) or if the size range cover more than 3 size ranges a relevant intermediate dummy(ies) shall be tested in addition to the dummy(ies) defined above.

- 7.1.3.6.1. If the **Enhanced** Child Restraint System is designed for two or more children, one test shall be carried out with the heaviest dummies occupying all seating positions. A second test with the lightest and the heaviest dummies specified above shall be carried out. The tests shall be conducted using the test bench as shown in Annex 6, Appendix 3, Figure 3. The laboratory conducting the tests may, if it deems it advisable, add a third test with any combination of dummies or empty seat positions.
- 7.1.3.6.2. If the i-Size **Enhanced** Child Restraint System uses a top tether, one test shall be carried out with the smallest dummy with the shorter distance of the top tether (anchorage point G1). A second test shall be carried out with the heavier dummy with the longer distance of the top tether (anchorage point G2). Adjust the top tether to achieve a tension load of 50 ± 5 N. For side lateral impact the ISOFIX **Enhanced** Child Restraint System shall be tested with only the shorter distance of the top tether.
- 7.1.3.6.3. If the i-Size **Enhanced** Child Restraint System uses a support-leg, as an anti-rotation device the hereafter mentioned dynamic tests shall be carried out as follows:
- (a) The tests for frontal impact shall be conducted with the support-leg adjusted to its maximum adjustment compatible with the positioning of the trolley floor pan. The tests for rear impact shall be conducted with the worst case position selected by the Technical Service. During the tests the support-leg shall be supported by the trolley floor pan as described in Annex 6, Appendix 2, Figure 2;
 - (b) In the case of support-legs out of the plane of symmetry, the worst case shall be selected by the Technical Service for the test;
 - (c) In the case of Specific vehicle ISOFIX category, the support-leg shall be adjusted as specified by the **Enhanced** Child Restraint System manufacturer;
 - (d) The leg length of a support-leg shall be adjustable in such a way that it is able to cover the complete span of floor pan levels that are allowed for in Regulation No. 16, Annex 17 for car seats to be approved for the installation i-Size **Enhanced** Child Restraints Systems.
- 7.1.3.6.4. The test specified in paragraph 6.6.4.1.6.2. above is a requirement only for the largest dummy for which the **Enhanced** Child Restraint System is designed.
- 7.2. Testing of individual components
- 7.2.1. Buckle
- 7.2.1.1. Opening test under load
- 7.2.1.1.1. An **Enhanced** Child Restraint System already having been subjected to the dynamic test specified in paragraph 7.1.3. above shall be used for this test.
- 7.2.1.1.2. The **Enhanced** Child Restraint System shall be removed from the test ~~trolley~~ **bench** or the vehicle without opening the buckle. A tension of 200 ± 2 N shall be applied to the buckle. If the buckle is attached to a rigid part, the

force shall be applied reproducing the angle formed between the buckle and that rigid part during the dynamic test.

- 7.2.1.1.3. A load shall be applied at a speed of 400 ± 20 mm/min to the geometric centre of the buckle-release button along a fixed axis running parallel to the initial direction of motion of the button; the geometric centre applies to that part of the surface of the buckle to which the release pressure is to be applied. The buckle shall be secured against a rigid support during the application of the opening force.
- 7.2.1.1.4. The buckle opening force shall be applied, using a dynamometer or similar device in the manner and direction of normal use. The contact end shall be a polished metal hemisphere with radius 2.5 ± 0.1 mm.
- 7.2.1.1.5. The buckle opening force shall be measured and any failure noted.
- 7.2.1.2. Opening test under zero load
 - 7.2.1.2.1. A buckle assembly which has not previously been subjected to a load shall be mounted and positioned under a "no load" condition.
 - 7.2.1.2.2. The method of measuring the buckle opening force shall be as prescribed in paragraphs 7.2.1.1.3. and 7.2.1.1.4. above.
 - 7.2.1.2.3. The buckle opening force shall be measured.
- 7.2.1.3. Strength testing
 - 7.2.1.3.1. For the strength test two samples have to be used. All adjusters, except for adjusters mounted directly on a **Enhanced Child Restraint System** are included in the test.
 - 7.2.1.3.2. Annex 16 shows a typical device for a buckle strength test. The buckle is placed on the upper round plate (A) within the relief. All adjacent straps have a length of at least 250 mm and are arranged hanging down from the upper plate respective to their position at the buckle. The free strap ends are then wound round the lower round plate (B) until they come out at the plate's inner opening. All straps have to be vertical between A and B. The round clamping plate (C) is then lightly clamped against the lower face of (B), still allowing a certain strap movement between them. With a small force at the tensile machine the straps are tensioned and pulled between (B) and (C) until all straps are loaded respective to their arrangement. The buckle shall stay free from plate (A) or any parts at (A) during this operation and the test itself. (B) and (C) are then clamped firmly together and the tensile force is increased at a traverse speed of 100 ± 20 mm/min until the required values are reached.
- 7.2.2. Adjusting device
 - 7.2.2.1. Ease of adjustment
 - 7.2.2.1.1. When testing a manual adjusting device, the strap shall be drawn steadily through the adjusting device, having regard for the normal conditions of use, at a rate of 100 ± 20 mm/min and the maximum force measured to the nearest integer value of N after the first 25 ± 5 mm of strap movement.
 - 7.2.2.1.2. The test shall be carried out in both directions of strap travel through the device, the strap being subjected to the full travel cycle 10 times prior to the measurement.
- 7.2.3. Microslip test (see Annex 5, Figure 3)

- 7.2.3.1. The components or devices to be subjected to the microslip test shall be kept for a minimum of 24 hours before testing in an atmosphere having a temperature of $20\text{ °C} \pm 5\text{ °C}$ and a relative humidity of 65 ± 5 per cent. The test shall be carried out at a temperature between 15 °C and 30 °C .
- 7.2.3.2. The free end of the strap shall be arranged in the same configuration as when the device is in use in the vehicle, and shall not be attached to any other part.
- 7.2.3.3. The adjusting device shall be placed on a vertical piece of strap one end of which bears a load of $50 \pm 0.5\text{ N}$ (guided in a manner which prevents the load from swinging and the strap from twisting). The free end of the strap from the adjusting device shall be mounted vertically upwards or downwards as it is in the vehicle. The other end shall pass over a deflector roller with its horizontal axis parallel to the plane of the section of strap supporting the load, the section passing over the roller being horizontal.
- 7.2.3.4. The device being tested shall be arranged in such a way that its centre, in the highest position to which it can be raised, is $300 \pm 5\text{ mm}$ from a support table, and the load of 50 N shall be $100 \pm 5\text{ mm}$ from that support table.
- 7.2.3.5. 20 ± 2 pre-test cycles shall then be completed and $1,000 \pm 5$ cycles shall then be completed at a frequency of 30 ± 10 cycles per minute, the total amplitude being $300 \pm 20\text{ mm}$ or as specified in paragraph 7.2.5.2.6.2. above. The 50 N load shall be applied only during the time corresponding to a shift of $100 \pm 20\text{ mm}$ for each half period. Microslip shall be measured from the position at the end of the 20 pre-test cycles.
- 7.2.4. Retractor
- 7.2.4.1. Retracting force
- 7.2.4.1.1. The retracting forces shall be measured with the ~~safety~~ **ECRS** belt assembly, fitted to a dummy as for the dynamic test prescribed in paragraph 7.1.3. above. The strap tension shall be measured at the point of contact with (but just clear of) the dummy while the strap is being retracted at the approximate rate of 0.6 m/min .
- 7.2.4.2. Durability of retractor mechanism
- 7.2.4.2.1. The strap shall be withdrawn and allowed to retract for the required number of cycles at a rate of not more than 30 cycles per minute. In the case of emergency-locking retractors, a jolt to lock the retractor shall be introduced at each fifth cycle. The jolts occur in equal numbers at each of five different extractions, namely, 90, 80, 75, 70 and 65 per cent of the total length of the strap on the retractor. However, where the length of the strap exceeds 900 mm the above percentage shall be related to the final 900 mm of strap which can be withdrawn from the retractor.
- 7.2.4.3. Locking of emergency-locking retractors
- 7.2.4.3.1. The retractor shall be tested once for locking, when the strap has been unwound to its full length less $300 \pm 3\text{ mm}$.
- 7.2.4.3.2. In the case of a retractor actuated by strap movement, the extraction shall be in the direction in which it normally occurs when the retractor is installed in a vehicle.
- 7.2.4.3.3. When retractors are being tested for sensitivity to vehicle accelerations, they shall be tested at the above extraction length in both directions along two mutually perpendicular axes which are horizontal if the retractors are to be

installed in a vehicle as specified by the **Enhanced Child Restraint System** manufacturer. When this position is not specified, the testing authority shall consult the **Enhanced Child Restraint System** manufacturer. One of these test directions shall be chosen by the Technical Service conducting the approval tests to give the most adverse conditions with respect to actuation of the locking mechanism.

- 7.2.4.3.4. The design of the apparatus used shall be such that the required acceleration is given at an average rate of increase of acceleration of at least 25 g/s.⁴
- 7.2.4.3.5. For testing compliance with the requirements of paragraphs 6.7.3.2.1.3. and 6.7.3.2.1.4. above the retractor shall be mounted on a horizontal table and the table tilted at a speed not exceeding 2° per second until locking has occurred. The test shall be repeated with tilting in other directions to ensure that the requirements are fulfilled.
- 7.2.4.4. Corrosion testing
 - 7.2.4.4.1. The corrosion testing shall be carried out as paragraph 7.1.1. above.
- 7.2.4.5. Dust resistance testing
 - 7.2.4.5.1. The retractor shall be positioned in a test chamber as described in Annex 3 to this Regulation. It shall be mounted in an orientation similar to that in which it is mounted in the vehicle. The test chamber shall contain dust as specified in paragraph 7.2.4.5.2. below. A length of 500 mm of the strap shall be extracted from the retractor and kept extracted, except that it shall be subjected to 10 complete cycles of retraction and withdrawal within one or two minutes after each agitation of the dust. For a period of five hours, the dust shall be agitated every 20 minutes for five seconds by compressed air free of oil and moisture at a gauge pressure of 5.5 ± 0.5 bars entering through an orifice 1.5 ± 0.1 mm in diameter.
 - 7.2.4.5.2. The dust used in the test described in paragraph 7.2.4.5.1. above shall consist of about 1 kg of dry quartz. The particle size distribution shall be as follows:
 - (a) Passing 150 µm aperture, 104 µm wire diameter: 99 to 100 per cent;
 - (b) Passing 105 µm aperture, 64 µm wire diameter: 76 to 86 per cent;
 - (c) Passing 75 µm aperture, 52 µm wire diameter: 60 to 70 per cent.
- 7.2.5. Static test for straps
 - 7.2.5.1. Strap strength test
 - 7.2.5.1.1. Each test shall be carried out on two new samples of strap, conditioned as specified in paragraph 6.7.4. of this Regulation.
 - 7.2.5.1.2. Each strap shall be gripped between the clamps of a tensile strength-testing machine. The clamps shall be so designed as to avoid breakage of the strap at or near them. The speed of traverse shall be 100 ± 20 mm/min. The free length of the specimen between the clamps of the machine at the start of the test shall be $200 \text{ mm} \pm 40 \text{ mm}$.
 - 7.2.5.1.2.1. The tension shall be increased until the strap breaks and the breaking load noted.

⁴ $g = 9.81 \text{ m/s}^2$.

- 7.2.5.1.3. If the strap slips or breaks at or within 10 mm of either of the clamps, the test shall be invalid and a new test shall be carried out on another specimen.
- 7.2.5.2. Samples out from straps, as referred to in paragraph 3.2.3. of this Regulation, shall be conditioned as follows:
- 7.2.5.2.1. Room conditioning
- 7.2.5.2.1.1. The strap shall be kept for 24 ± 1 hours in an atmosphere having a temperature of $23 \text{ }^\circ\text{C} \pm 5 \text{ }^\circ\text{C}$ and a relative humidity of 50 ± 10 per cent. If the test is not carried out immediately after conditioning, the specimen shall be placed in a hermetically closed receptacle until the test begins. The breaking load shall be determined within five minutes after removal of the strap from the conditioning atmosphere or from the receptacle.
- 7.2.5.2.2. Light conditioning
- 7.2.5.2.2.1. The provisions of Recommendation ISO/105-B02 (1978), shall apply. The strap shall be exposed to light for the time necessary to produce fading of Standard Blue Dye No. 7 to a contrast equal to Grade 4 on the grey scale.
- 7.2.5.2.2.2. After exposure, the strap shall be kept for a minimum of 24 hours in an atmosphere having a temperature of $23 \text{ }^\circ\text{C} + 5 \text{ }^\circ\text{C}$ and a relative humidity of 50 ± 10 per cent. The breaking load shall be determined within five minutes after the removal of the strap from the conditioning installation.
- 7.2.5.2.3. Cold conditioning
- 7.2.5.2.3.1. The strap shall be kept for a minimum of 24 hours in an atmosphere having a temperature of $23 \text{ }^\circ\text{C} \pm 5 \text{ }^\circ\text{C}$ and a relative humidity of 50 ± 10 per cent.
- 7.2.5.2.3.2. The strap shall then be kept for 90 ± 5 minutes on a plain surface in a low-temperature chamber in which the air temperature is $-30 \text{ }^\circ\text{C} \pm 5 \text{ }^\circ\text{C}$. It shall then be folded and the fold shall be loaded with a weight of 2 ± 0.2 kg previously cooled to $-30 \text{ }^\circ\text{C} \pm 5 \text{ }^\circ\text{C}$. When the strap has been kept under load for 30 ± 5 minutes in the same low-temperature chamber, the weight shall be removed and the breaking load shall be measured within five minutes after removal of the strap from the low-temperature chamber.
- 7.2.5.2.4. Heat conditioning
- 7.2.5.2.4.1. The strap shall be kept for 180 ± 10 minutes in a heating-cabinet atmosphere having a temperature of $60 \text{ }^\circ\text{C} \pm 5 \text{ }^\circ\text{C}$ and a relative humidity 65 ± 5 per cent.
- 7.2.5.2.4.2. The breaking load shall be determined within five minutes after removal of the strap from the heating cabinet.
- 7.2.5.2.5. Exposure to water
- 7.2.5.2.5.1. The strap shall be kept fully immersed for 180 ± 10 minutes in distilled water, at a temperature of $20 \text{ }^\circ\text{C} \pm 5 \text{ }^\circ\text{C}$, to which a trace of wetting agent has been added. Any wetting agent suitable for the fibre being tested may be used.
- 7.2.5.2.5.2. The breaking load shall be determined within 10 minutes after removal of the strap from the water.
- 7.2.5.2.6. Abrasion conditioning
- 7.2.5.2.6.1. The components or devices to be submitted to the abrasion test shall be kept for a minimum of 24 hours before testing in an atmosphere having a

temperature of $23\text{ }^{\circ}\text{C} \pm 5\text{ }^{\circ}\text{C}$ and a relative humidity of 50 ± 10 per cent. The room temperature during the testing shall be between $15\text{ }^{\circ}\text{C}$ and $30\text{ }^{\circ}\text{C}$.

7.2.5.2.6.2. The table below sets out the general conditions for each test:

Table 8

	<i>Load (N)</i>	<i>Cycles per minute</i>	<i>Cycles (No.)</i>
Type 1 procedure	10 ± 0.1	30 ± 10	$1,000 \pm 5$
Type 2 procedure	5 ± 0.05	30 ± 10	$5,000 \pm 5$

Where there is insufficient strap to test over 300 mm of shift, the test may be applied over a shorter length subject to a minimum of 100 mm.

7.2.5.2.6.3. Particular test conditions

7.2.5.2.6.3.1. Type 1 procedure: For cases where the strap slides through the quick adjusting device. The 10 N load shall be vertically and permanently applied on one of the straps. The other strap, set horizontally, shall be attached to a device, giving the webbing a back and forth motion. The adjusting device shall be so placed that the horizontal strap of the webbing remains under tension (see Annex 5, Figure 1).

7.2.5.2.6.3.2. Type 2 procedure: For cases where the strap changes direction in passing through a rigid part. During this test, the angles of both webbing straps shall be as shown in Annex 5, Figure 2. The 5 N load shall be permanently applied. For cases where the strap changes direction more than once in passing through a rigid part, the load of 5 N may be increased so as to achieve the prescribed 300 mm of strap movement through that rigid part.

7.2.6. Conditioning test for adjusters mounted directly on a **Enhanced Child Restraint System**.

Install the largest dummy for which the restraint is intended, as if for the dynamic test, including the standard slack as specified in paragraph 7.1.3.5. above. Mark a reference line on the webbing where the free end of the webbing enters the adjuster.

Remove the dummy and place the restraint in the conditioning rig shown in Figure 1, Annex 16.

The webbing shall be cycled for a total distance of not less than 150 mm through the adjuster. This movement shall be such that at least 100 mm of webbing on the side of the reference line towards the free end of the webbing and the remainder of the moving distance (approx. 50 mm) on the integral harness side of the reference line moves through the adjuster.

If the length of webbing from the reference line to the free end of the webbing is insufficient for the movement described above, the 150 mm of movement through the adjuster shall be from the fully extended harness position.

The frequency of cycling shall be 10 ± 1 cycles/minute, with a velocity on "B" of 150 ± 10 mm/sec.

7.2.7. Temperature test

- 7.2.7.1. The components specified in paragraph 6.6.5.1. above shall be exposed to an environment over a water surface within a closed space, the environment having a temperature of not less than 80 °C, for a continuous period of not less than 24 hours and then cooled in an environment having a temperature not exceeding 23 °C. The cooling period shall immediately be followed by three consecutive 24 hour cycles with each cycle comprising the following consecutive sequences:
- (a) An environment having a temperature of not less than 100 °C shall be maintained for a continuous period of 6 hours and this environment shall be attained within 80 minutes of commencement of the cycle; then
 - (b) An environment having a temperature of not more than 0 °C shall be maintained for a continuous period of 6 hours and this environment shall be attained within 90 minutes; then
 - (c) An environment having a temperature of not more than 23 °C shall be maintained during the remainder of the 24 hour cycle.
- 7.2.8. The complete seat, or the component fitted with ISOFIX attachments (e.g. ISOFIX base) if it has a release button, is attached rigidly to a test rig in such a way that ISOFIX connectors are vertically aligned as shown in Figure 3. A 6 mm diameter bar, 350 mm long, shall be attached to the ISOFIX connectors. A mass of 5 kg shall be attached to the extremities of the bar.
- 7.2.8.1. An opening force shall be applied to the release button or handle along a fixed axis running parallel to the initial direction of motion of the button/handle; the geometric centre applies to that part of the surface of the ISOFIX attachment to which the release pressure is to be applied.
- 7.2.8.2. The ISOFIX attachment opening force shall be applied using a dynamometer or similar device in the normal manner and direction as indicated in the manufacturers user manual. The contact end shall be a polished metal hemisphere with radius 2.5 ± 0.1 mm for a release button or a polished metal hook with a radius of 25 mm.
- 7.2.8.3. If the design of the **Enhanced Child Restraint System** prevents the application of the procedure described in paragraphs 7.2.8.1. and 7.2.8.2., an alternative method may be applied with the agreement of the Technical Service carrying out the test.
- 7.2.8.4. The ISOFIX attachment opening force to be measured shall be that needed to disengage the first connector.
- 7.2.8.5. The test shall be carried out on a new seat, and repeated on a seat that has been subjected to the cycling procedure specified in paragraph 6.7.5.1.

Figure 3

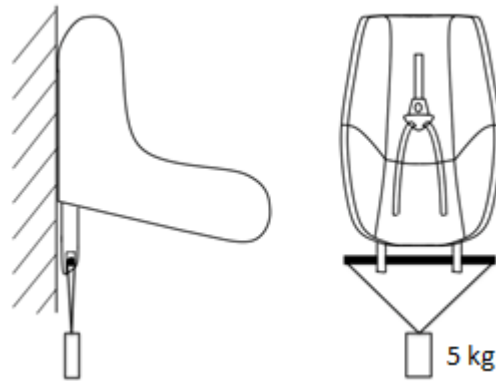

- 7.3. Certification of test bench cushion.
- 7.3.1. The test bench seat cushion shall be certified when new to establish initial values for impact penetration and peak deceleration, and then after every 50 dynamic tests or at least every month, whichever is the sooner, or before each test if the test rig is used frequently.
- 7.3.2. The certification and measuring procedures shall correspond to those specified in the latest version of ISO 6487; the measuring equipment shall correspond to the specification of a data channel with a channel filter class (CFC) 60.
- Using the test device defined in Annex 14 to this Regulation, conducts three tests, 150 ± 5 mm from the front edge of the cushion on the centre line and at 150 ± 5 mm in each direction from the centre line.
- Place the device vertically on a flat rigid surface. Lower the impact mass until it contacts the surface and set the penetration marker to the zero position. Place the device vertically above the test point, raise the mass 500 ± 5 mm and allow it to fall freely to make impact on the test bench seat cushion surface. Record the penetration and the deceleration curve.
- 7.3.3. The peak values recorded shall not deviate by more than 15 per cent from the initial values.
- 7.4. Registration of dynamic behaviour
- 7.4.1. In order to determine the behaviour of the dummy and its displacements, all dynamic tests shall be registered according to the following conditions:
- 7.4.1.1. Filming and recording conditions:
- (a) The frequency shall be at least 1,000 frames per second;
 - (b) The test shall be recorded on video or digital data carrier over at least the first 300 ms.
- 7.4.1.2. Estimation of uncertainty:
- Testing laboratories shall have and shall apply procedures for estimating uncertainty of measurement of the displacement of the dummy's head. The uncertainty shall be within ± 25 mm.

Examples of international standards of such procedure are EA-4/02 of the European Accreditation Organization or ISO 5725:1994 or the General Uncertainty Measurement (GUM) method.

- 7.5. The measuring procedures shall correspond to those defined in the latest version of ISO 6487. The channel frequency class shall be:

Table 9

<i>Type of measurement</i>	<i>CFC(F_H)</i>	<i>Cut-off frequency (F_N)</i>
Trolley acceleration	60	see ISO 6487 Annex A
Belt loads	60	see ISO 6487 Annex A
Chest acceleration	180	see ISO 6487 Annex A
Head acceleration	1,000	1,650 Hz
Upper neck force	1,000	
Upper neck moment	600	
Chest deflection	600	

The sampling rate should be a minimum of 10 times the channel frequency class (i.e. in installations with channel frequency class of 1,000, this corresponds to a minimum sampling rate of 10,000 samples per second per channel).

8. Test reports of type approval and of production qualification

- 8.1. The test report shall record the results of all tests and measurements including the following test data:
- (a) The type of device used for the test (acceleration or deceleration device);
 - (b) The total velocity change;
 - (c) The trolley speed immediately before impact only for deceleration sleds;
 - (d) The acceleration or deceleration curve during all the velocity change of the trolley and at least 300 ms;
 - (e) The time (in ms) when the head of the dummy reaches its maximum displacement during the performance of the dynamic test;
 - (f) The place occupied by the buckle during the tests, if it can be varied;
 - (g) Any failure or breakage;
 - (h) The following dummy criteria: HIC, Head Acceleration 3 ms, Upper Neck Tension Force, Upper Neck Moment, Thorax Chest Deflection; and
 - (i) ~~The lap-belt force.~~ **Adult Seat belt bench installation forces.**
- 8.2. If provisions relating to anchorages contained in Annex 6, Appendix 3, to this Regulation have not been respected, the test report shall describe how the **Enhanced Child Restraint System** is installed and shall specify important angles and dimensions.

- 8.3. When the **Enhanced Child Restraint System** is tested in a vehicle or vehicle structure, the test report shall specify the manner of attaching the vehicle structure to the trolley, the position of the **Enhanced Child Restraint System** and vehicle seat and the inclination of the vehicle seat-back.
- 8.4. The test reports of type approval and of production qualification shall record the verification of markings and of instructions on installation and use.

9. Production qualification

- 9.1. In order to make sure that the manufacturer's production system is satisfactory, the Technical Service, which conducted the type approval tests, shall carry out tests to qualify production in accordance with paragraph 9.2. below.

- 9.2. Qualifying the production of **Enhanced Child Restraint Systems**

The production of each new approved type of **Child Restraint System** ~~of categories i Size and specific to vehicle~~ shall be subjected to production qualification tests. Additional qualifications of production may be prescribed following paragraph **11.4**.

For this purpose, a random sample of 5 **Enhanced** Child Restraint Systems will be taken from the first production batch. The first production batch is considered to be the production of the first block containing a minimum of 50 **Enhanced** Child Restraint Systems and a maximum of 5,000 **Enhanced** Child Restraint Systems.

- 9.2.1. Dynamic tests for frontal and rear impact
- 9.2.1.1. Five **Enhanced** Child Restraint Systems shall be subjected to the dynamic test described in paragraph 7.1.3. above. The Technical Service that conducted the type approval tests shall choose the conditions that produced the maximum horizontal head excursion during the type approval dynamic tests, excluding the conditions described in paragraph 6.6.4.1.6.2. above. All the five **Enhanced** Child Restraint Systems shall be tested under the same conditions.
- 9.2.1.2. For each test described in paragraph 9.2.1.1. above, the injury criteria described in paragraph 6.6.4.3.1. above; and
- For forward facing the head excursion described in paragraph 6.6.4.4.1.1. above;
- For rearward facing and carrycots the head **excursion** described in paragraph 6.6.4.4.1.2.1. above ~~and head excursion described in 6.6.4.4.1.2.2. above;~~
- Shall be measured.
- 9.2.1.3. The maximum head excursion results shall comply with the following two conditions:
- 9.2.1.3.1. No value shall exceed 1.05 L, and
- $X + S$ shall not exceed L
- Where:

L = the limit value prescribed

X = the mean of the values

S = the standard deviation of the values.

- 9.2.1.3.2. The injury criteria results shall comply with the requirements of paragraph 6.6.4.3.1. above and, in addition, the X + S condition in paragraph 9.2.1.3.1. above shall be applied to the 3 ms clipped injury criteria results (as defined in para. 6.6.4.3.1. above) and recorded for information only.
- 9.2.2. Dynamic tests for lateral impact
- 9.2.3. Control of markings
 - 9.2.3.1. The Technical Service that conducted the approval tests shall verify that the markings conform to the requirements of paragraph 4. of this Regulation.
 - 9.2.3.2. Control of instructions on installation and the instructions for use.
 - 9.2.3.3. The Technical Service that conducted the approval tests shall verify that the instructions on installation and the instructions for use conform to paragraph 14. of this Regulation.

10. Conformity of production and routine tests

The conformity of production procedures shall comply with those set out in the Agreement, Appendix 2 (E/ECE/324–E/ECE/TRANS/505/Rev.2), with the following requirements:

- 10.1. Any **Enhanced Child Restraint System** approved to this Regulation shall be so manufactured as to conform to the type approved by meeting the requirements set forth in paragraphs 6. to 7. above.
- 10.2. The minimum requirements for conformity of production control procedures set forth in Annex 12 to this Regulation shall be complied with.
- 10.3. The Type Approval Authority which has granted type approval may at any time verify the conformity control methods applied in each production facility. The normal frequency of these verifications shall be twice a year.

11. Modification and extension of approval of an Enhanced Child Restraint System

- 11.1. Every modification of a **Enhanced Child Restraint System** shall be notified to the Type Approval Authority which approved the **Enhanced Child Restraint System**. The Type Approval Authority may then either:
 - 11.1.1. Consider that the modifications made are unlikely to have an appreciable adverse effect and that in any case the **Enhanced Child Restraint System** still complies with the requirements; or
 - 11.1.2. Require a further test report from the Technical Service responsible for conducting the tests.

- 11.2. Confirmation or refusal of approval, specifying the alterations, shall be communicated by the procedure specified in paragraph 5.3. above to the Parties to the Agreement applying this Regulation.
- 11.3. The Type Approval Authority issuing the extension of approval shall assign a series number for such an extension and inform thereof the other Parties to the 1958 Agreement applying this Regulation by means of a communication form conforming to the model in Annex 1 to this Regulation.
- 11.4. If a further test report is required, compare the horizontal head excursion result with the worst case from all results previously recorded:
- (a) If the excursion is greater, then new production qualification testing must be carried out;
 - (b) If the excursion is less, production qualification tests do not need to be carried out.

12. Penalties for non-conformity of production

- 12.1. The approval granted in respect of a **Enhanced** Child Restraint System pursuant to this Regulation may be withdrawn if a **Enhanced** Child Restraint System bearing the particulars referred to in paragraph 5.4. of this Regulation fails to pass the random checks described in paragraph 9. above or does not conform to the type approved.
- 12.2. If a Party to the Agreement which applies this Regulation withdraws an approval it has previously granted, it shall forthwith so notify the other Contracting Parties applying this Regulation by means of a communication form conforming to the model in Annex 1 to this Regulation.

13. Production definitively discontinued

- 13.1. If the holder of the approval completely ceases to manufacture a specific type of **Enhanced** Child Restraint System under this Regulation, he shall inform thereof the Type Approval Authority which granted the approval. Upon receiving the relevant communication, that Type Approval Authority shall inform the other Parties to the Agreement which apply this Regulation by means of a communication form conforming to the model in Annex 1 to this Regulation.

14. Information for users [To be reviewed]

- 14.1. Each **Enhanced** Child Restraint System shall be accompanied by instructions in the language of the country where the device is sold with the following content:
- 14.2. Instructions on installation shall include the following points:
- 14.2.1. For "i-Size" category **Enhanced** Child Restraint Systems the following label shall be clearly visible on the exterior of the packing:

Notice

This is an "i-Size" **Enhanced** Child Restraint System. It is approved **according to Regulation No.129**, for use in, "i-Size compatible" vehicle seating positions as indicated by vehicle manufacturers in the vehicle users' manual.

If in doubt, consult either the **Enhanced Child Restraint System** manufacturer or the retailer.

- 14.2.2. For universal booster category Enhanced Child Restraint Systems the following label shall be clearly visible on the exterior of the packing:**

Notice

This is a universal booster Enhanced Child Restraint System. It is approved according to Regulation No. 129, for use in, universal "booster vehicle seating positions" as indicated by vehicle manufacturers in the vehicle users' manual.

If in doubt, consult either the Enhanced Child Restraint System manufacturer or the retailer.

- 14.2.3. For "Specific vehicle **ISOFIX**" category **Enhanced** Child Restraint Systems information on the applicable vehicle shall be clearly visible at the point of sale without removing the **Enhanced Child Restraint System** from its packing;
- 14.2.4. The **Enhanced Child Restraint System** manufacturer shall provide information on the exterior packaging as to the address to which the customer can write to obtain further information on fitting the **Enhanced Child Restraint System** in specific cars;
- 14.2.5. The method of installation illustrated by photographs and/or very clear drawings;
- 14.2.6. The user shall be advised that the rigid items and plastic parts of a **Enhanced Child Restraint System** shall be so located and installed that they are not liable, during everyday use of the vehicle, to become trapped by a movable seat or in a door of the vehicle;
- 14.2.7. The user should be advised to use carry-cots perpendicular to the longitudinal axis of the vehicle;
- 14.2.8. In the case of rearward facing **Enhanced Child Restraint** Systems the customer shall be advised not to use them in seating positions where there is an active frontal airbag installed. This information shall be clearly visible at the point of sale without removing the packaging;
- 14.2.9. For "i-Size Special Needs Restraints" the following information shall be clearly visible at the point of sale without removing the **Enhanced Child Restraint System** from its packing:

This "i-Size Special Needs Restraint" is designed to give extra support to children who have difficulty in sitting correctly in conventional seats. Always consult your doctor to make sure that this restraint system is suitable for your child.

- 14.3. The instructions for use shall include the following points:

- 14.3.1. The "Size range" and the maximum occupant mass for which the device is intended;
- 14.3.2. The method of use shall be shown by photographs and/or very clear drawings. In the case of seats that can be used both forward and rearward facing, clear warning shall be given to keep the **Enhanced** Child Restraint System rearward facing until the child's age is greater than a stated limit, or some other dimensional criterion is exceeded;
- 14.3.3. For forward facing **Enhanced** Child Restraint System, the following information shall be clearly visible on the exterior of the packing:

"IMPORTANT - DO NOT USE FORWARD FACING BEFORE THE CHILD'S AGE EXCEEDS 15 months (Refer to instructions)".
- 14.3.4. The operation of the buckle and adjusting devices shall be explained clearly;
- 14.3.5. It shall be recommended that any straps holding the restraint to the vehicle should be tight, that any support-leg should be in contact with the vehicle floor, that any straps restraining the child should be adjusted to the child's body, and that straps should not be twisted;
- 14.3.6. The importance of ensuring that any lap strap is worn low down, so that the pelvis is firmly engaged, shall be stressed;
- 14.3.7. It shall be recommended that the device should be replaced when it has been subject to violent stresses in an accident;
- 14.3.8. Instructions for cleaning shall be given;
- 14.3.9. A general warning shall be given to the user concerning the danger of making any alterations or additions to the device without the approval of the Type Approval Authority, and a danger of not following closely the installation instructions provided by the **Enhanced Child Restraint System** manufacturer;
- 14.3.10. When the chair is not provided with a textile cover, it shall be recommended that the chair should be kept away from sunlight, otherwise it may be too hot for the child's skin;
- 14.3.11. It shall be recommended that children are not left in their **Enhanced** Child Restraint System unattended;
- 14.3.12. It shall be recommended that any luggage or other objects liable to cause injuries in the event of a collision shall be properly secured.
- 14.3.13. It shall be recommended that:
 - 14.3.13.1. The **Enhanced** Child Restraint System shall not be used without the cover;
 - 14.3.13.2. The **Enhanced** Child Restraint System cover should not be replaced with any other than the one recommended by the manufacturer, because the cover constitutes an integral part of the restraint performance.
- 14.3.14. There shall be provisions made so that the instructions can be retained on the **Enhanced Child Restraint System** for its life period or in the vehicle handbook in the case of built-in restraints.
- 14.3.15. For an "i-Size **Enhanced** Child Restraint System, the user shall also be referred to the vehicle manufacturer's handbook.

15. Names and addresses of Technical Services responsible for conducting approval tests and of Type Approval Authorities

The Parties to the 1958 Agreement applying this Regulation shall communicate to the United Nations Secretariat the names and addresses of the Technical Services responsible for conducting approval tests and of the Type Approval Authorities which grant approval and to which forms certifying approval or extension or refusal or withdrawal of approval, or production definitively discontinued, issued in other countries, are to be sent.

[16. Transitional provisions

- 16.1. As from the official date of entry into force of the 01 series of amendments, no Contracting Party applying this Regulation shall refuse to grant ECE approval under this Regulation as amended by the 01 series of amendments.**
- 16.2. As from 12-months after the date of entry into force of the 01 series of amendments, Contracting Parties applying this Regulation shall grant approvals only if the Enhanced Child Restraint System type to be approved meets the requirements of this Regulation as amended by the 01 series of amendments.**
- 16.3. During the 12-month period which follows the date of entry into force of the 01 series of amendments, Contracting Parties applying this Regulation can continue to grant type approvals to those Enhanced Child Restraint Systems which comply with the requirements of this Regulation as in its original version.**
- 16.4. During the 36-month period which follows the date of entry into force of the 01 series of amendments, Contracting Parties applying this Regulation shall not refuse to grant extensions of approval to the original version of this Regulation.]**

Annex 1

Communication

(Maximum format: A4 (210 x 297 mm))



issued by: Name of administration:

.....
.....
.....

- concerning:²
- Approval granted
 - Approval extended
 - Approval refused
 - Approval withdrawn
 - Production definitively discontinued

of restraining devices for child occupants of power-driven vehicles, pursuant to Regulation No. 129.

Approval No.: Extension No.:

- 1.1. Forward-facing **Enhanced Child Restraint System** /rearward-facing **Enhanced Child Restraint System** /lateral-facing **Enhanced Child Restraint System**
- 1.2. Integral/partial/booster cushion;²
- 1.3. Belt type:²
 - (Adult) three-point belt
 - (Adult) lap belt
 - Special type belt/retractor²
- 1.4. Other features: chair assembly/impact shield²
2. Trade name or mark
3. Manufacturer's designation of the **Enhanced Child Restraint System**
4. Manufacturer's name
5. If applicable, name of his representative
6. Address

¹ Distinguishing number of the country which has granted/extended/refused/withdrawn approval (see approval provisions in the Regulation).
² Strike out what does not apply.

7. Submitted for approval on
8. Technical Service conducting approval tests
9. Type of device: deceleration/acceleration²
10. Date of test report issued by that Service
11. Number of test report issued by that Service
12. Approval granted/extended/refused/withdrawn² for size range x to x for i-Size specific vehicle or for use as a "special needs restraint", position in vehicle.....
13. Position and nature of the marking
14. Place
15. Date
16. Signature
17. The following documents, bearing the approval number shown above, are attached to this communication:
 - (a) Drawings, diagrams and plans of the **Enhanced Child Restraint System**, including any retractor, chair assembly, impact shield fitted;
 - (b) Drawings, diagrams and plans of the vehicle structure and the seat structure, as well as of the adjustment system and the attachments, including any energy absorber fitted;
 - (c) Photographs of the **Enhanced Child Restraint System** and/or vehicle structure and seat structure;
 - (d) Instructions for fitting and use;
 - (e) List of vehicle models for which the restraint is intended.

Annex 2

Arrangements of the approval mark

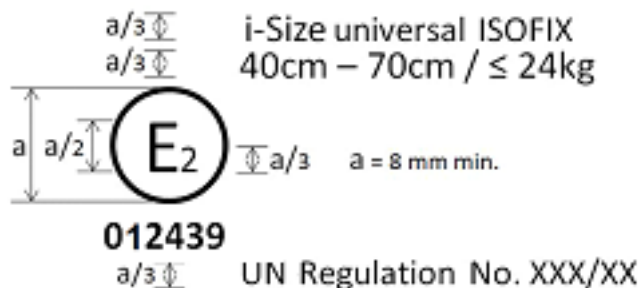

The **Enhanced** Child Restraint System bearing the above approval mark is a device capable of being fitted in any i-size compatible vehicle **seating position** and of being used for the 40 cm \varnothing - 70 cm size range and mass limit of 24 kg; it is approved in France (E 2) under the number 012439. The approval number indicates that the approval was granted in accordance with the requirements of the Regulation concerning the approval of **Enhanced Child Restraint Systems** used onboard of motor vehicles as amended by the 01 series of amendments. In addition the name of the regulation has to be identified on the approval mark followed by the series of amendment according to which the approval has been granted.



The **Enhanced** Child Restraint System bearing the above approval mark is a device not capable of being fitted in every vehicle and capable of being used for the 40 cm \varnothing - 70 cm size range and mass limit of 24 kg; it is approved in France (E 2) under the number 012450. The approval number indicates that the approval was granted in accordance with the requirements of the Regulation concerning the approval of Specific vehicle ISOFIX **Enhanced Child Restraint Systems** used onboard of motor vehicles as amended by the 01 series of amendments. In addition the name of the regulation has to be identified on the approval mark followed by the series of amendment according to which the approval has been granted.

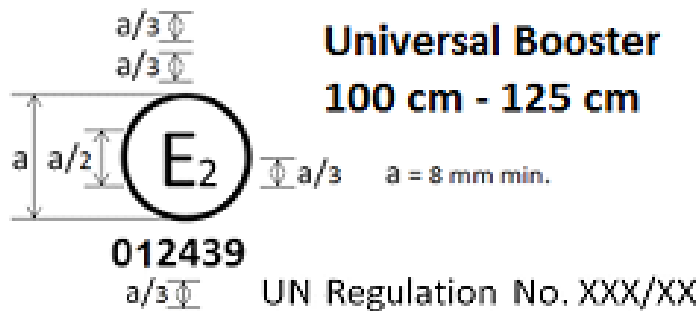

The Enhanced Child Restraint System bearing the above approval mark is a device capable of being fitted in any Universal Booster Vehicle seating position and of being used for the 100 cm - 125 cm size range; it is approved in France (E 2) under the number 012439. The approval number indicates that the approval was granted in accordance with the requirements of the Regulation concerning the approval of Enhanced Child Restraint Systems used onboard of motor vehicles as amended by the 01 series of amendments. In addition the name of the regulation has to be identified on the approval mark followed by the series of amendment according to which the approval has been granted.

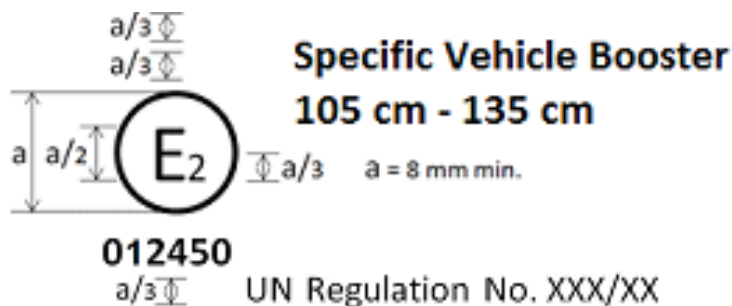

The Enhanced Child Restraint System bearing the above approval mark is a device not capable of being fitted in every vehicle but capable of being used for the 105 cm - 135 cm size range; it is approved in France (E 2) under the number 012450. The approval number indicates that the approval was granted in accordance with the requirements of the Regulation concerning the approval of Specific Vehicle Booster Enhanced Child Restraint Systems used onboard of motor vehicles as amended by the 01 series of amendments. In addition the name of the regulation has to be identified on the approval mark followed by the series of amendment according to which the approval has been granted.

Note: The approval number and additional symbol(s) shall be placed close to the circle and either above or below the "E" or to left or right of it. The digits of the approval number shall be on the same side of the "E" and oriented in the same direction. The additional symbol(s) shall be diametrically opposite the approval number. The use of Roman numerals as approval numbers should be avoided so as to prevent any confusion with other symbols.

Annex 3

Arrangement of apparatus for dust resistance test

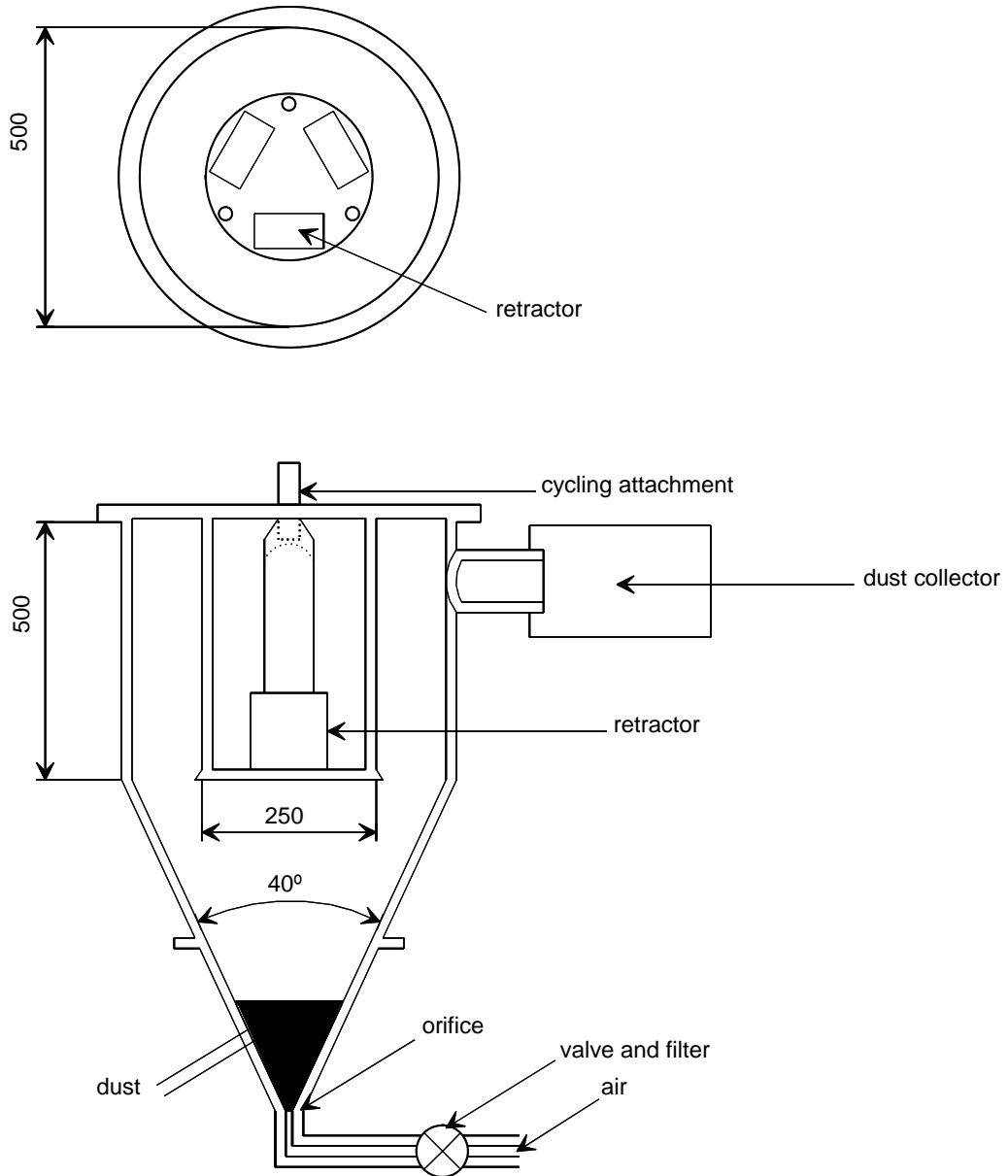

Annex 4

Corrosion test

1. Test apparatus
 - 1.1. The apparatus shall consist of a mist chamber, a salt solution reservoir, a supply of suitably conditioned compressed air, one or more atomizing nozzles, sample supports, provision for heating the chamber, and necessary means of control. The size and detailed construction of the apparatus shall be optional, provided that the test conditions are met.
 - 1.2. It is important to ensure that drops of solution accumulated on the ceiling or cover of the chamber do not fall on test samples.
 - 1.3. Drops of solution which fall from test samples shall not be returned to the reservoir for respraying.
 - 1.4. The apparatus shall not be constructed of materials that will affect the corrosiveness of the mist.
2. Location of test samples in the mist cabinet
 - 2.1. Samples, except retractors, shall be supported or suspended between 15° and 30° from the vertical and preferably parallel to the principal direction of horizontal flow of mist through the chamber, based upon the dominant surface being tested.
 - 2.2. Retractors shall be supported or suspended so that the axes of the reel for storing the strap shall be perpendicular to the principal direction of horizontal flow of mist through the chamber. The strap opening in the retractor shall also be facing in this principal direction.
 - 2.3. Each sample shall be so placed as to permit free settling of mist on all samples.
 - 2.4. Each sample shall be so placed as to prevent salt solution from one sample dripping on to any other sample.
3. Salt solution
 - 3.1. The salt solution shall be prepared by dissolving 5 ± 1 parts by mass of sodium chloride in 95 parts of distilled water. The salt shall be sodium chloride substantially free of nickel and copper and containing not more than 0.1 per cent of sodium iodide and not more than 0.3 per cent of total impurities in the dry state.
 - 3.2. The solution shall be such that, when atomized at 35 °C, the collected solution is in the pH range of 6.5 to 7.2.
4. Compressed air
 - 4.1. The compressed air supply to the nozzle or nozzles for atomizing the salt solution shall be free of oil and dirt, and maintained at a pressure between 70 kN/m² and 170 kN/m².

5. Conditions in the mist chamber
 - 5.1. The exposure zone of the mist chamber shall be maintained at $35\text{ °C} \pm 5\text{ °C}$. At least two clean mist collectors shall be placed within the exposure zone, so that no drops of solution from the test samples or any other sources are collected. The collectors shall be placed near the test samples, one as near as possible to any nozzle and one as far as possible from all nozzles. The mist shall be such that, for each 80 cm^2 of horizontal collecting area, from 1.0 to 2.0 ml of solution per hour, when measured over an average of at least 16 hours, is collected in each collector.
 - 5.2. The nozzle or nozzles shall be directed or baffled, so that the spray does not impinge directly on the test samples.

Annex 5

Abrasion and microslip test

Figure 1
Procedure type 1

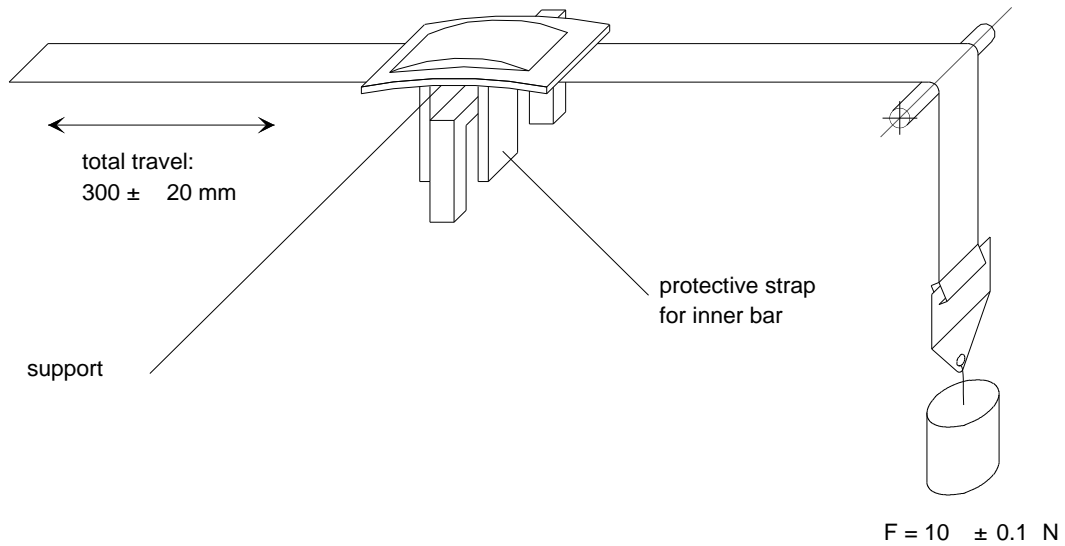

Example a

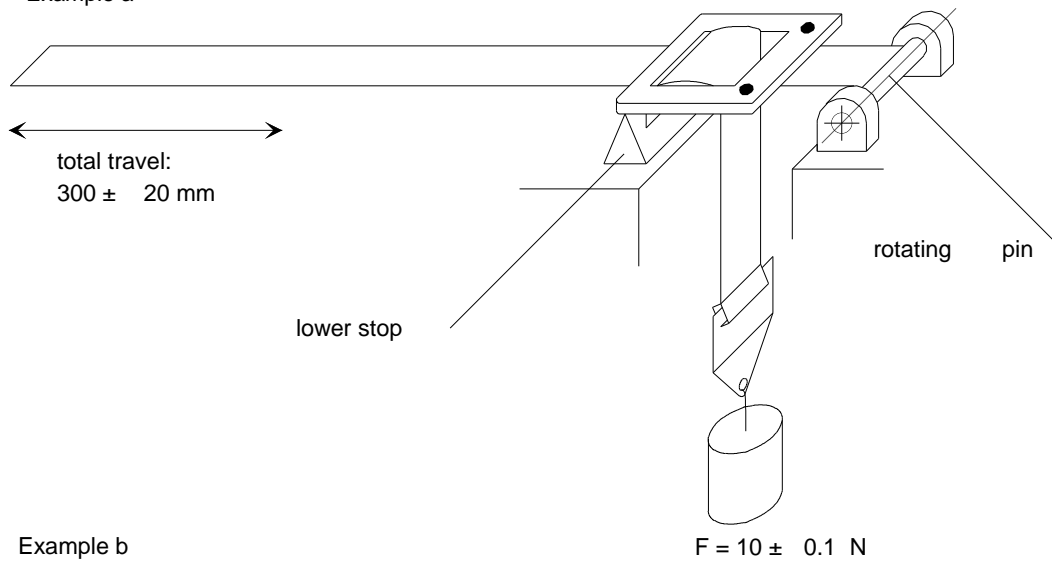

Example b
Examples of test arrangements corresponding
to the type of adjusting device

Figure 2
Procedure type 2

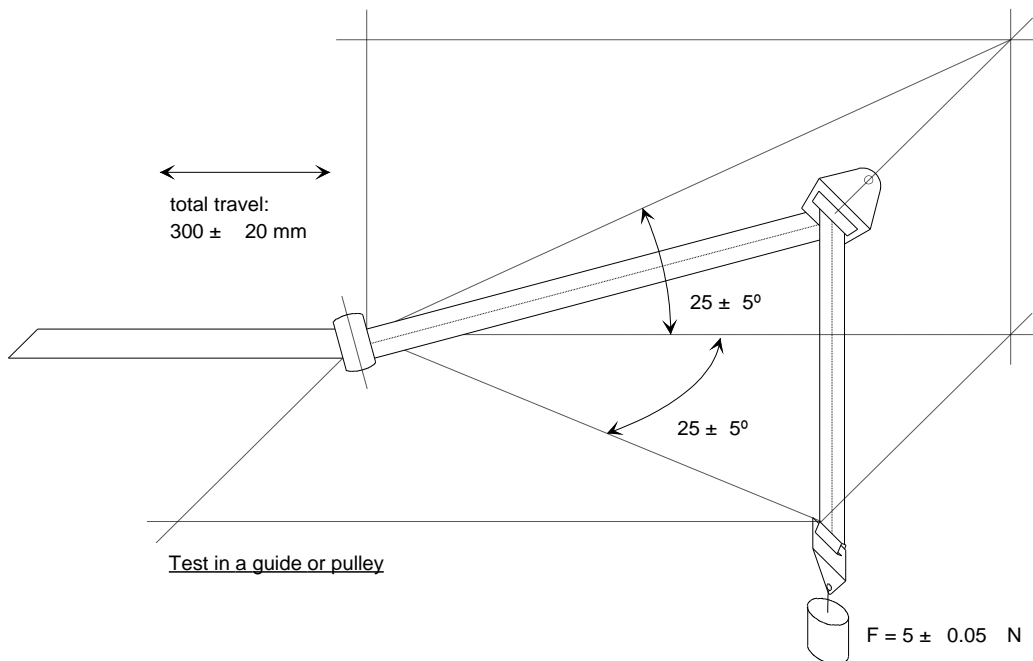
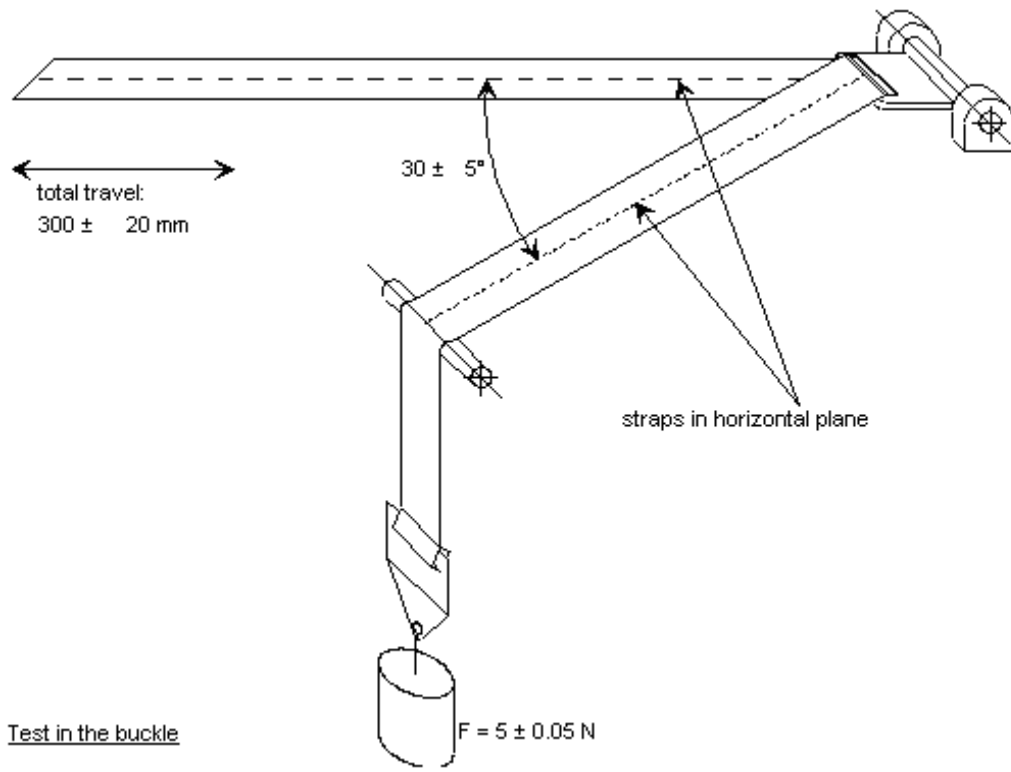
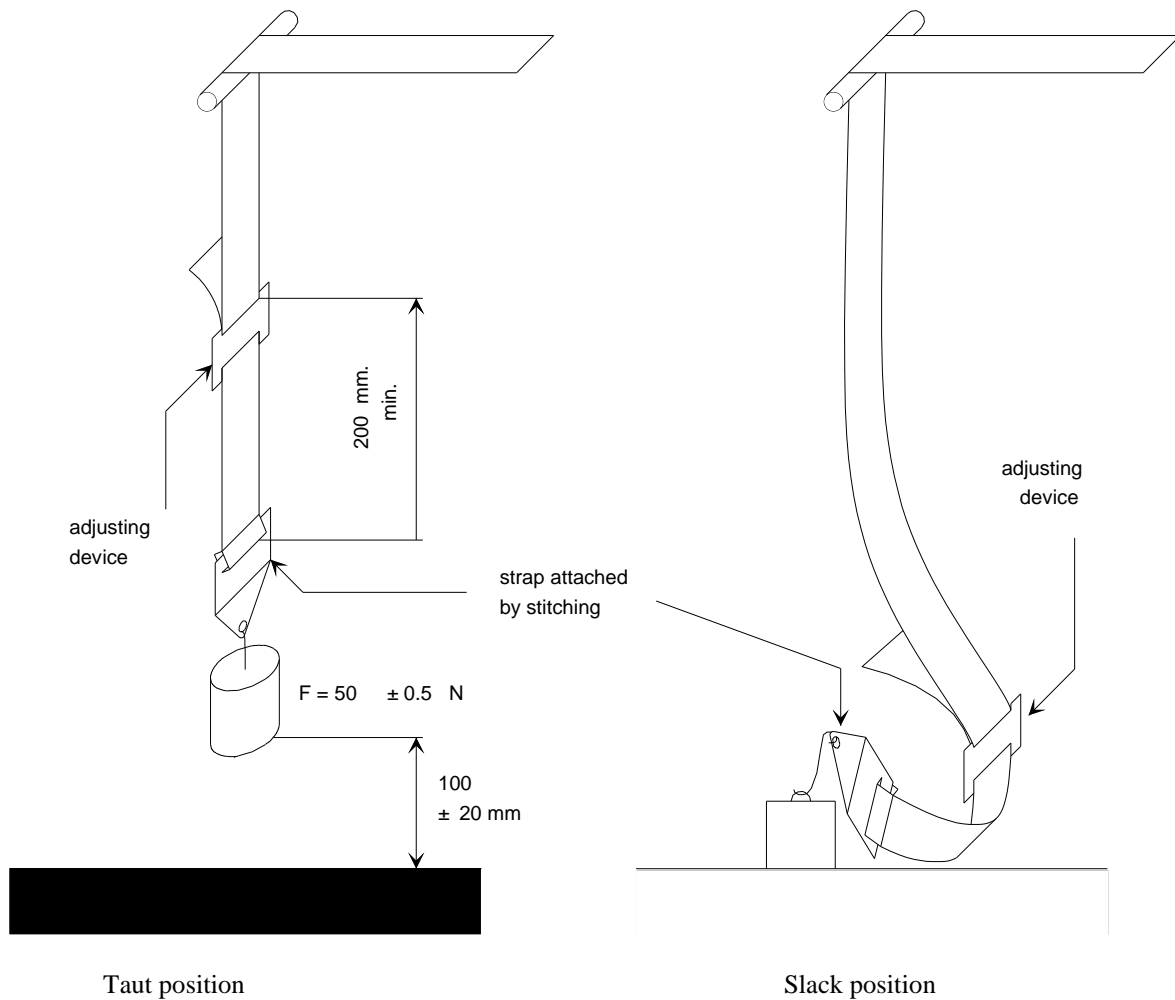

Figure 3
Microslip Test

Total travel: 300 ± 20 mm



The load of 50 N on the testing device shall be vertically guided in such a way as to prevent load-swing and twisting of the strap.

The attaching device shall be fixed to the load of 50 N in the same manner as in the vehicle.

Annex 6

Description of trolley

1. Trolley
 - 1.1. For tests on **Enhanced Child Restraints System**, the trolley, carrying the seat only, shall have a mass greater than 380 kg. For tests on **Enhanced Child Restraint Systems** in the "Specific vehicle' ISOFIX" category, the trolley with the attached vehicle structure shall have a mass greater than 800 kg.
2. Calibration screen
 - 2.1. A calibration screen shall be attached firmly to the trolley with a movement limit line plainly marked on it to enable compliance with forward movement criteria to be determined from photographic records.
3. Test bench
 - 3.1. The test bench shall be constructed as follows:
 - 3.1.1. A rigid back, fixed, dimensions of which are given in Appendix 1 to this annex;
 - 3.1.2. Rigid seating, dimensions of which are given in Appendix 1 to this annex. The rear part of the seating is made from a rigid sheet metal,. The front part of the seating is also made of a 20 mm diameter tube;
 - 3.1.3. For access to the ISOFIX anchorage system, openings shall be made at the rear of the test bench seat cushion, as prescribed in Appendix 1 to this annex;
 - 3.1.4. The width of the test bench shall be 800 mm;
 - 3.1.5. The back and the seating shall be covered with polyurethane foam, the characteristics of which are given in Table 1. The dimensions of the cushion are given in Appendix 1 to this annex;

Table 1

	<i>Standard</i>	<i>Value</i>	<i>Unit</i>
Density	EN ISO 845	68-74	Kg/m ³
Compression resistance	EN ISO 3386/1 (40 % compression)	13	kPa
Indentation Load Deflection (ILD)	EN ISO 2439B (40 % compression)	500 (+/15%)	N
Tensile strength	EN ISO 1798	≥ 150	kPa
Ultimate elongation	EN ISO 1798	≥ 120	%
Compression set	EN ISO 1856 (22hr/50 %/70 °C)	≤ 3	%

- 3.1.6. The polyurethane foam shall be covered with a sun shade cloth, made of poly-acrylate fibre, the characteristics of which are given in Table 2.

Table 2

Specific mass (g/m ²)	290
Breaking strength according to DIN 53587 on test specimen 50 mm wide:	
Lengthwise (kg):	120
Breadth wise (kg):	80

- 3.1.7. Covering the test bench seat cushion and the test bench seat back cushion
- 3.1.7.1. The test bench seat cushion is produced out of a square foam block (800 x 575 x 135 mm) in such a way (see Figure 1 of Appendix 1 to this annex) that its shape resembles the shape of the aluminium bottom-plate specified in Figure 2 of Appendix 1 to this annex.
- 3.1.7.2. Six holes are drilled in the bottom-plate in order to fasten it to the trolley with bolts. The holes are drilled alongside the longest side of the plate, three on each side, their position being dependent on the construction of the trolley. Six bolts are put through the holes. It is recommended to glue the bolts on the plate with an appropriate adhesive. Afterwards, the bolts are fastened with nuts.
- 3.1.7.3. The cover material (1,250 x 1,200 mm, see Figure 3 of Appendix 1 to this annex) is cut across the width in such a way that it is not possible for the material to overlap after covering. There should be a gap of about 100 mm between the edges of the cover material. Therefore the material has to be cut at about 1,200 mm.
- 3.1.7.4. The cover material is marked with two lines which run across the width. They are drawn 375 mm from the centreline of the cover material (see Figure 3 of Appendix 1 to this annex).
- 3.1.7.5. The test bench seat cushion is placed upside down on the cover material with the aluminium bottom-plate on top.
- 3.1.7.6. On both sides the cover material is stretched until the lines drawn on it match the edges of the aluminium bottom-plate. At each bolt position, small incisions are made and the cover material is pulled over the bolts.
- 3.1.7.7. At the position of the grooves in the bottom-plate and in the foam, the cover material should be incised.
- 3.1.7.8. The cover is glued to the aluminium plate with flexible glue. The nuts have to be removed before gluing.
- 3.1.7.9. The flaps on the side are folded onto the plate and are glued as well.
- 3.1.7.10. The flaps in the grooves are folded inside and taped with a strong tape.
- 3.1.7.11. The flexible glue has to dry for at least 12 hours.
- 3.1.7.12. The test bench seat-back cushion is covered in exactly the same way as the test bench seat cushion, only the lines on the cover material (1,250 x 850 mm) are drawn 333 mm apart from the centreline of the material.

- 3.1.8. Line Cr is coincident with the intersection line between the top plane of the test bench seat cushion and the front plane of the test bench seat-back cushion.
- 3.2. Test of rearward-facing devices
- 3.2.1. A special frame shall be fitted on the trolley in order to support the **Enhanced Child Restraint System** as shown in Figure 1.
- 3.2.2. A steel tube shall be attached firmly to the trolley in such a way that a load of $5,000 \pm 50$ N applied horizontally to the centre of the tube does not cause a movement greater than 2 mm.
- 3.2.3. The dimensions of the tube shall be: 500 x 100 x 90 mm.

Figure 1
Arrangements for testing a rearward - facing device

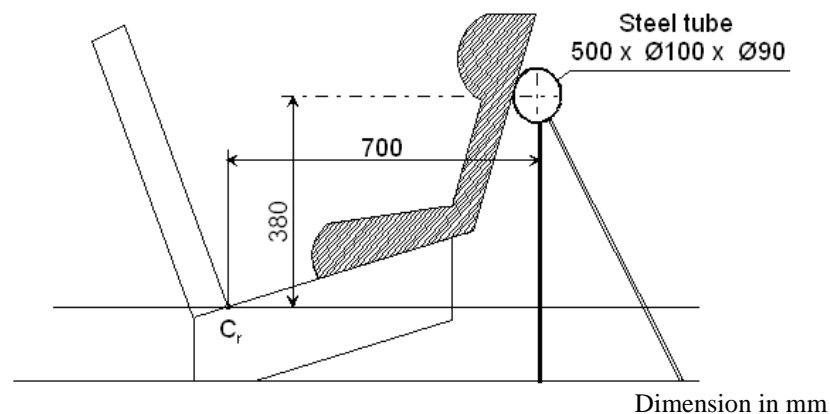

- 3.3. Trolley floor pan
- 3.3.1. The floor pan of the trolley shall be constructed of a flat sheet of metal of uniform thickness and material, see Figure 2 of Appendix 3 to this annex.
- 3.3.1.1. The floor pan shall be rigidly mounted on the trolley. The height of the floor pan relative to the C_r axis projection point, dimension¹ in **Annex 6** Appendix 2, Figure 2, shall be adjusted to meet the requirements of paragraph 7.1.3.6.3.
- 3.3.1.2. The floor pan shall be designed so that the surface hardness should not be below 120 HB, according to EN ISO 6506-1:1999.
- 3.3.1.3. The floor pan shall withstand an applied vertical concentrated load of 5 kN without causing a vertical movement greater than 2 mm referring to C_r axis and without any permanent deformation occurring.
- 3.3.1.4. The floor pan shall have a surface roughness not exceeding Ra 6,3 according to ISO 4287:1997.

¹ The dimension shall be of 210 mm with an adjustment range of ± 70 mm.

- 3.3.1.5. The floor pan shall be designed so that no permanent deformation is occurring after a dynamic test of a **Enhanced Child Restraint System**, according to this Regulation.
- 4. Stopping device
 - 4.1. The device consists of two identical absorbers mounted in parallel.
 - 4.2. If necessary, an additional absorber shall be used for each 200 kg increase in nominal mass. Each absorber shall comprise:
 - 4.2.1. An outer casing formed from a steel tube;
 - 4.2.2. A polyurethane energy-absorber tube;
 - 4.2.3. A polished-steel olive-shaped knob penetrating into the absorber; and
 - 4.2.4. A shaft and an impact plate.
 - 4.3. The dimensions of the various parts of this absorber are shown in the diagram reproduced in Appendix 2 to this annex.
 - 4.4. The characteristics of the absorbing material are given in Table 3 and Table 4 of this annex.
 - 4.5. The stopping device assembly shall be maintained for at least 12 hours at a temperature between 15 °C and 25 °C before being used for the calibration tests described in Annex 7 to this Regulation. The stopping device shall, for each type of test, meet the performance requirements laid down in Annex 7, Appendices 1 and 2. For dynamic tests of a **Enhanced Child Restraint System**, the stopping device assembly shall be maintained for at least 12 hours at the same temperature, to within ± 2 °C, as that of the calibration test. Any other device giving equivalent results can be accepted.

Table 3
Characteristics of the absorbing material "A"²

<i>(ASTM Method 2000 (1980) unless otherwise stated)</i>	
Shore hardness A:	88 ± 2 at 20 °C ± 5 °C temperature
Breaking strength:	$R_o \geq 300 \text{ kg/cm}^2$
Minimum elongation:	$A_o \geq 400 \text{ percent}$
Module at 100 per cent elongation:	$\geq 70 \text{ kg/cm}^2$
Module at 300 per cent elongation:	$\geq 130 \text{ kg/cm}^2$
Low temperature brittleness (ASTM Method D 736):	5 hours at -55 °C
Compression set (Method B):	22 hours at 70 °C ≤ 45 per cent
Density at 25 °C:	1.08 to 1.12
Ageing in air (ASTM Method D 573 (1981)):	
70 hours at 100 °C:	Shore hardness: max. variation ±3 Breaking strength: decrease < 10 per cent of R_o Elongation: decrease < 10 per cent of A_o Weight: decrease < 1 per cent
Immersion in oil (ASTM Method D 471 (1979) Oil No. 1):	
70 hours at 100 °C:	Shore hardness: max. variation ±4 Breaking strength: decrease < 15 per cent of R_o Elongation: decrease < 10 per cent of A_o Volume: swelling < 5 per cent
Immersion in oil (ASTM Method D 471 (1979) Oil No. 3):	
70 hours at 100 °C:	Breaking strength: decrease < 15 per cent of R_o Elongation: decrease < 15 per cent of A_o Volume: swelling < 20 per cent
Immersion in distilled water:	
1 week at 70 °C:	Breaking strength: decrease < 35 per cent of R_o
	Elongation: increase < 20 per cent of A_o

² The address to obtain the relevant ASTM standards is: ASTM, 1916 Race Street, Philadelphia, USA PA 19 103.

Table 4
Characteristics of the Absorbing Material "B"

<i>ASTM Method 2000 (1980) unless otherwise stated</i>	
Shore hardness A:	88 ± 2 at $20 \text{ }^\circ\text{C} \pm 5 \text{ }^\circ\text{C}$ temperature
Breaking strength:	$R_o \geq 300 \text{ kg/cm}^2$
Minimum elongation:	$A_o \geq 400$ percent
Module at 100 per cent elongation:	$\geq 70 \text{ kg/cm}^2$
Module at 300 per cent elongation:	$\geq 130 \text{ kg/cm}^2$
Low temperature brittleness (ASTM Method D 736):	5 hours at $-55 \text{ }^\circ\text{C}$
Compression set (Method B):	22 hours at $70 \text{ }^\circ\text{C} \leq 45$ percent
Density at $25 \text{ }^\circ\text{C}$:	1.08 to 1.12
Ageing in air (ASTM Method D 573 (1981)):	
70 hours at $100 \text{ }^\circ\text{C}$:	Shore hardness: max. variation ± 4 Breaking strength: decrease < 15 percent of R_o Elongation: decrease < 10 percent of A_o Volume: swelling < 5 percent
Immersion in oil (ASTM Method D 471 (1979) Oil No. 3):	
70 hours at $100 \text{ }^\circ\text{C}$:	Breaking strength: decrease < 15 percent of R_o Elongation: decrease < 15 percent of A_o Volume: swelling < 20 percent
Immersion in distilled water:	
1 week at $70 \text{ }^\circ\text{C}$	Breaking strength: decrease < 35 percent of R_o
	Elongation: increase < 20 percent of A_o

Annex 6 - Appendix 1

Figure 1
Dimensions in mm of the seat and the seat cushions

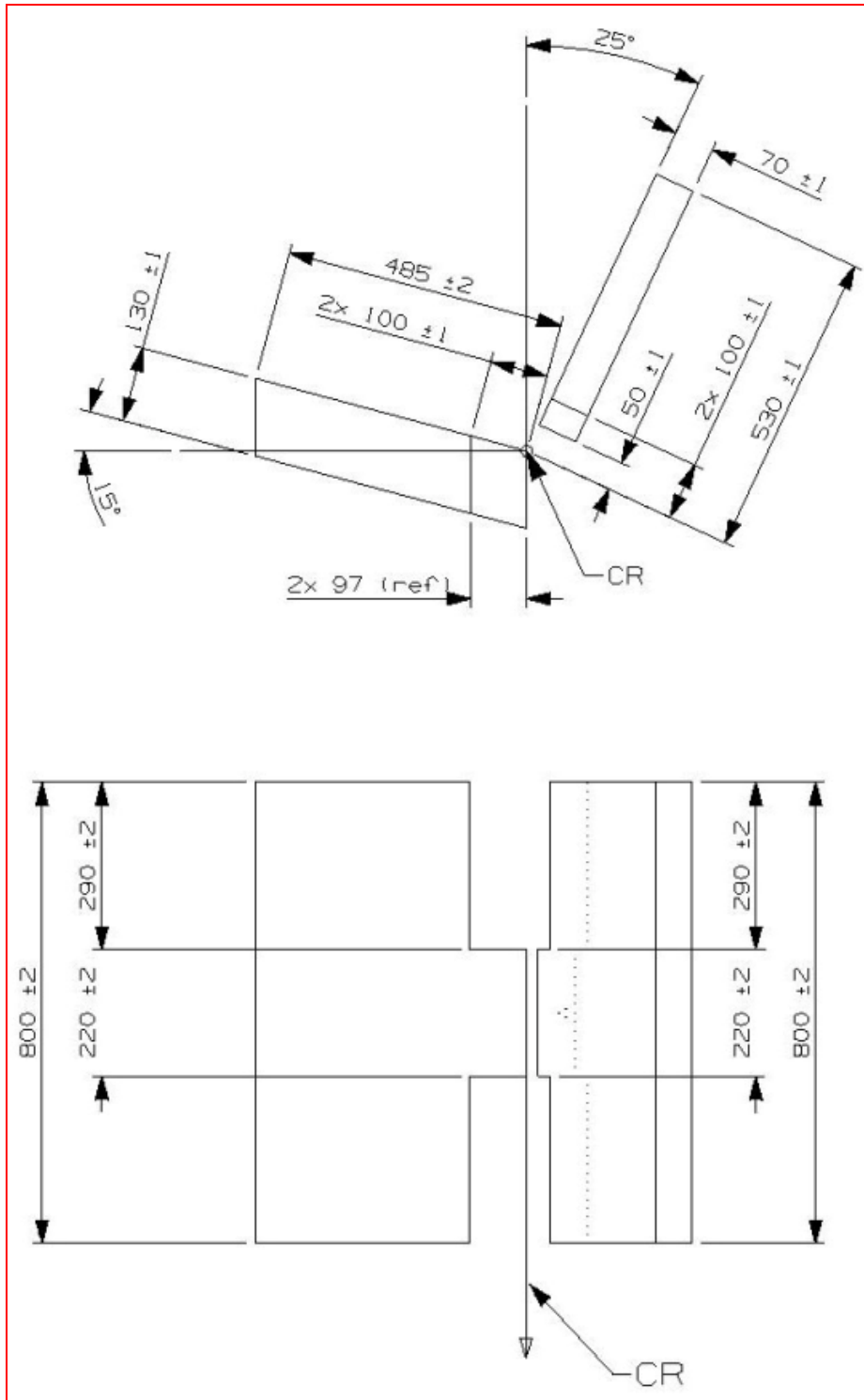

Figure 2
Dimensions of the aluminum bottom-plate and dimensions of the aluminium backrest plate

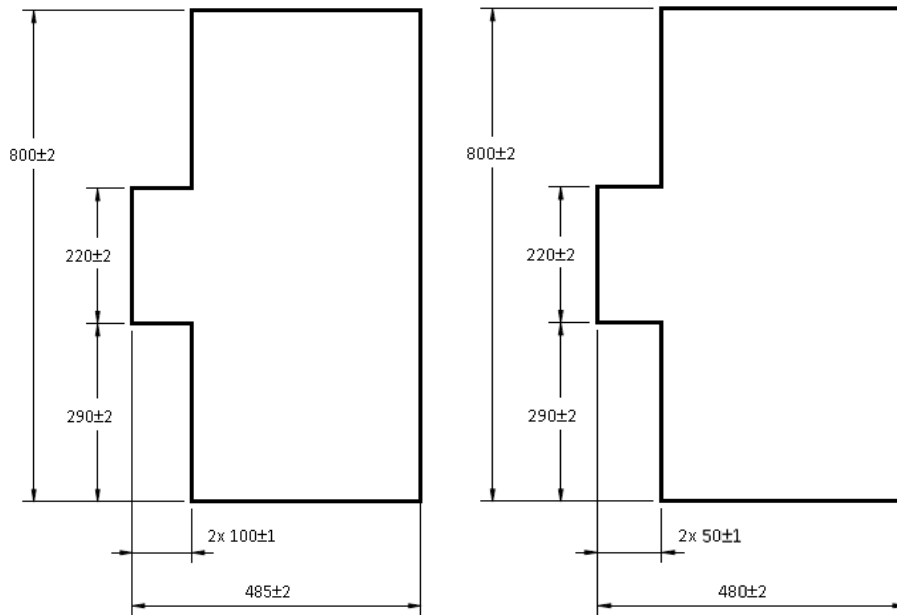
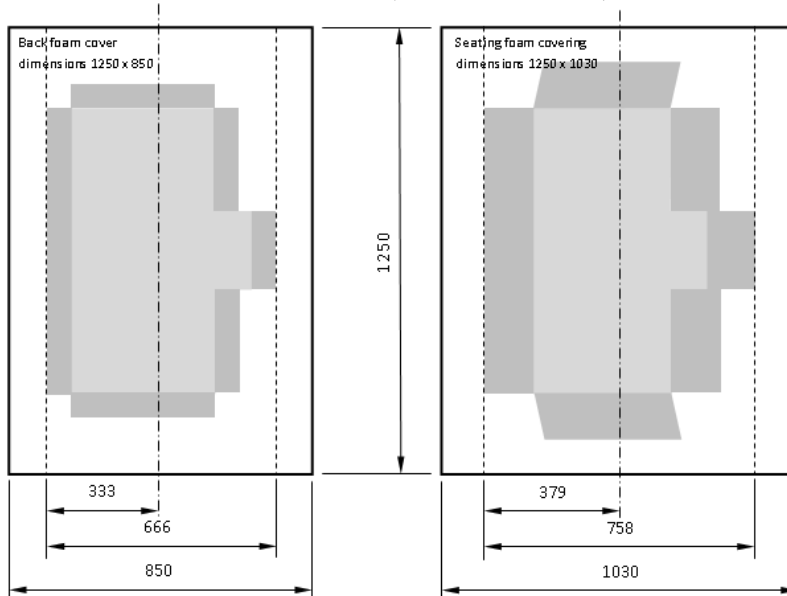

Figure 3
Dimensions of the cover material (dimensions in mm)



Annex 6 - Appendix 2

Arrangement and use of anchorages on the test trolley

1. The anchorages shall be positioned as shown in the figure below.
2. **Enhanced** Child Restraint Systems in the i-Size "universal", "specific" and "restricted" categories shall use the following anchorage points: H₁ and H₂.
3. For testing of **Enhanced** Child Restraint Systems with top tether, the anchorage G₁ or G₂ shall be used.
4. In the case of **Enhanced** Child Restraint Systems utilising a support-leg, the Technical Service shall select the anchorages to be used according to paragraph 3. above and with the support-leg adjusted as specified in paragraph 7.1.3.6.3. of this Regulation.
5. The structure carrying the anchorages shall be rigid. The upper anchorages shall not be displaced by more than 0.2 mm in the longitudinal direction when a load of 980 N is applied to them in that direction. The trolley shall be so constructed that no permanent deformation shall occur in the parts bearing the anchorages during the test.

Figure 1

Top View – Bench with anchorages (Tolerance general: ±2)

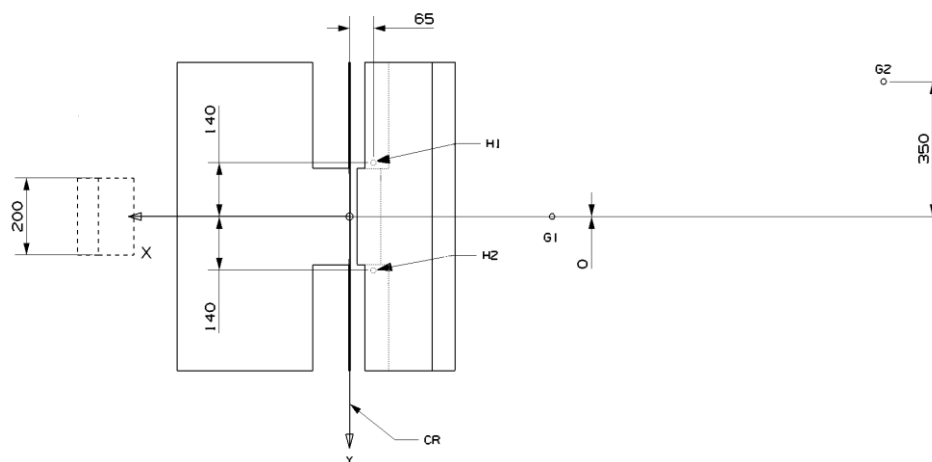
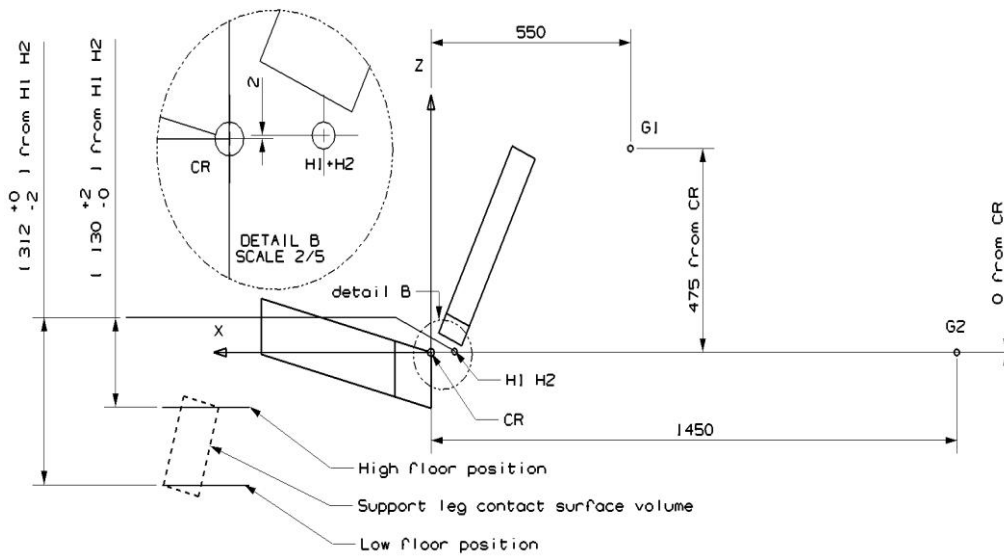

Figure 2
Side View – Bench with anchorages (Tolerance general: ± 2)



Definition of belt anchorages

The next table gives the belt anchorages points.

Table 1
Suggested lowered anchorage

Direction	Upper Anchorage (P)			Buckle (A2)			Lower outer (A1)		
	X	Y	Z	X	Y	Z	X	Y	Z
Distance (mm)	-240	-220	-630	-29	200	59	10	-200	14.5

Annex 6 - Appendix 3

Definition of side impact door

1. Door panel definition

The dimension and initial position of the impact door relative to the bench are described in the following figures.

The stiffness and strength of the door panel shall be sufficient to avoid excessive oscillation or significant deformation during lateral dynamic test.

Figure 1
Door panel geometry and position at T0 – Top view

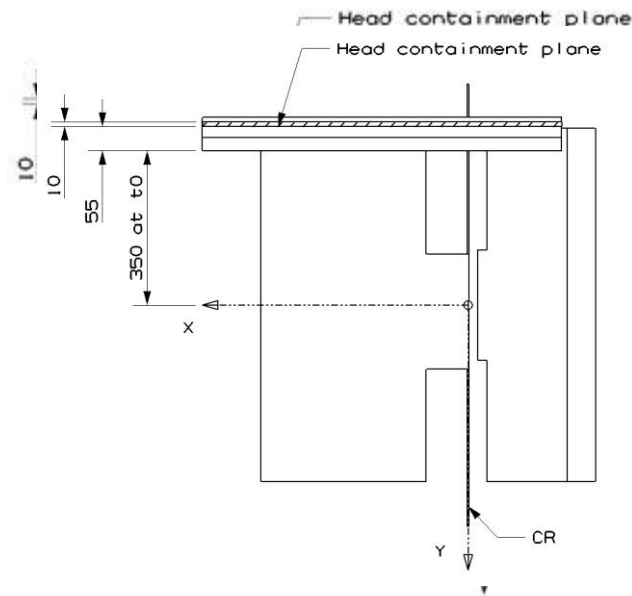

Figure 2
Door panel geometry – Side view

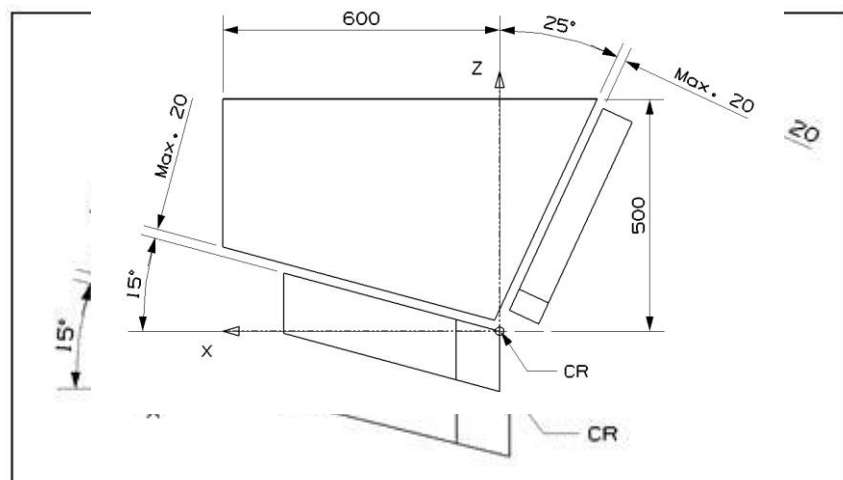
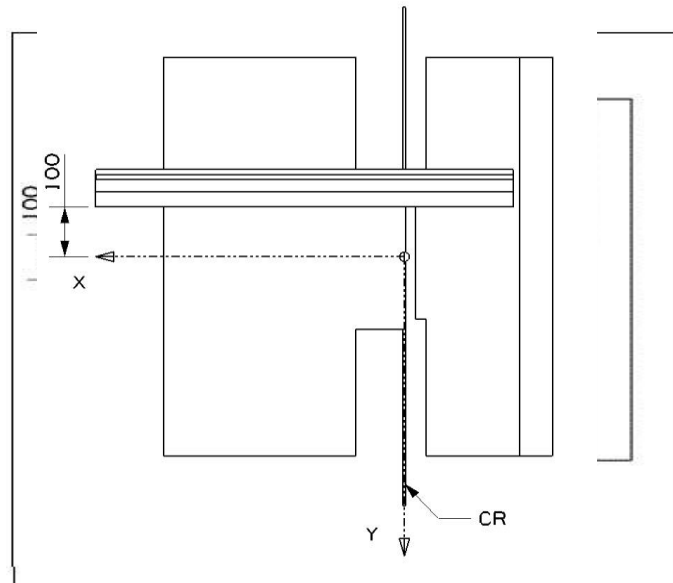

Figure 3
Door panel approximate maximum intrusion – Side view (For information)



2. Panel padding specification

2.1. General

The impacting surface of the door panel shall be entirely covered with a padding material 55 mm in thickness (see Figure 1 above). The material shall comply with the performance criteria specified in paragraph 2.3 (figure 4 bellow). of this appendix when tested in accordance with paragraph 2.2. of this appendix.

A material combination that has been found to meet these requirements is detailed in paragraph 2.4. of this appendix.~~The door panel is padded with 55 mm padding material (Annex 6, Appendix 3, Figure 1), which has to comply with the performance criteria as described in Appendix 3 to this Regulation, paragraph 2.3. realised in a test set up as described in Appendix 3 to this Regulation, paragraph 2.2.~~

2.2. Test procedure for the assessment of panel padding material

The test set up consists of a simple drop test using a spherical head form. The spherical head form has a diameter of 150 mm and a mass of 6 kg (± 0.1 kg). The impact speed is 4 m/s (± 0.1 m/s). The instrumentation should allow the assessment of the time of first contact between the impactor and the sample as well as the head form acceleration at least in direction of impact (Z-direction).

The material sample should have the dimensions of 400 x 400 mm. The sample should be impacted in its centre.

2.3. Performance criteria for the padding material

The time of first contact between sample material and head form (t_0) is 0 ms.

The impactor acceleration shall not exceed 58 g.

Figure 4
Corridor for the padding material

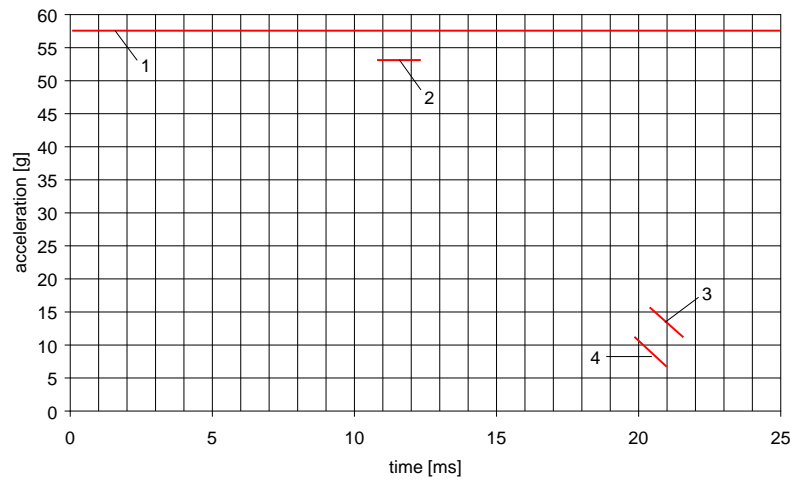

Key

- 1 - Upper limit of 58 g
- 2 - Lower limit for the maximum peak at 53 g (11 to 12 ms)
- 3 - Upper limit for the decline of acceleration (15 g at 20,5 ms to 10 g at 21,5 ms)
- 4 - Lower limit for the decline of acceleration (10 g at 20 ms to 7 g at 21 ms)

2.4. Example of material meeting the test requirements:

Rubber cell foam Polychloropren CR4271 measuring 35 mm in thickness attached to the door panel structure to which shall then be attached a subsequent layer of Styrodur C2500 20 mm in thickness. The Styrodur needs to be replaced after each test.

Annex 6 - Appendix 4

Stopping device Frontal impact dimensions (in mm)

Figure 1

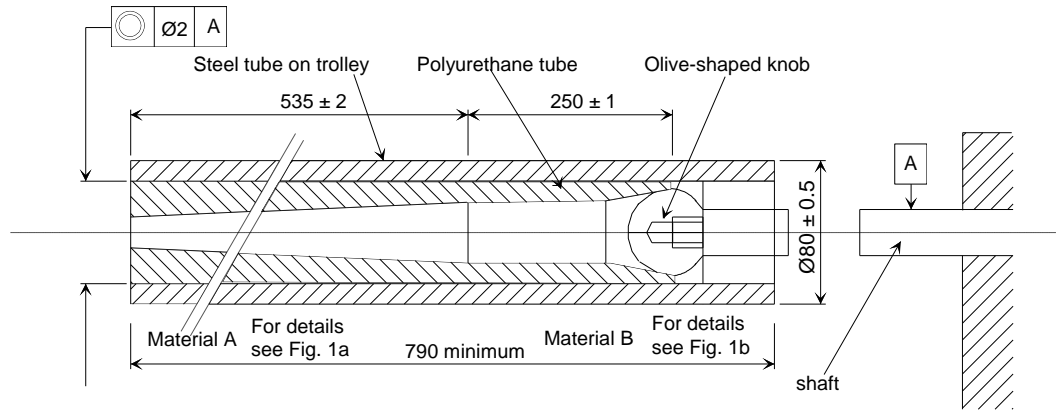

Play defined according to external diameter of polyurethane tube (light push fit)

3.2  surface finish

Figure 1a
Material A

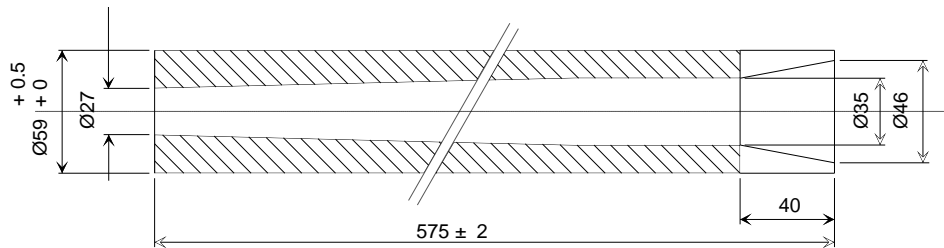

Figure 1b
Material B

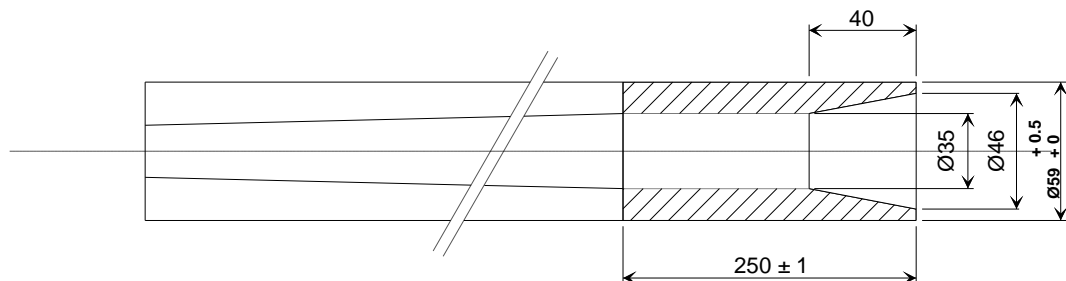
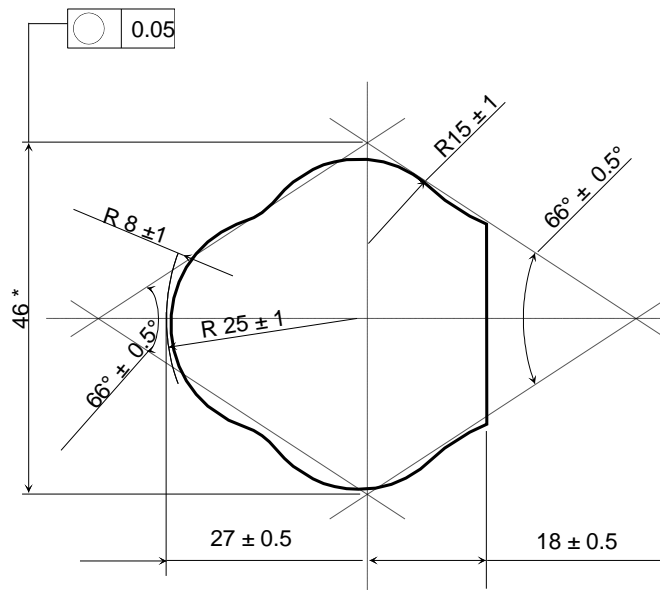

Figure 2
Stopping device olive-shaped knob



* This dimension can vary between 43 and 49 mm

Dimensions in mm

Figure 3
Stopping device olive-shaped knob

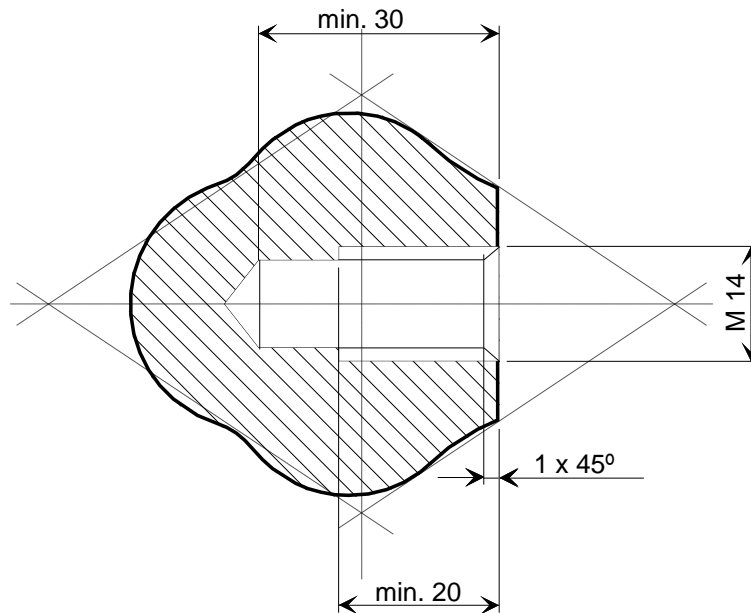

Dimensions in mm

Figure 4

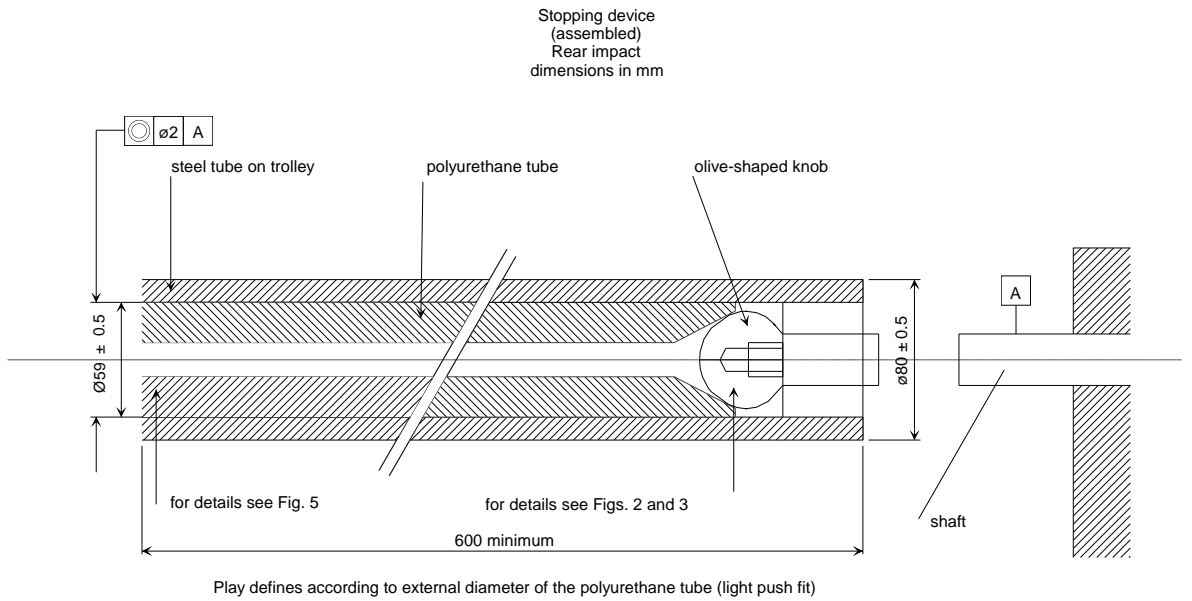
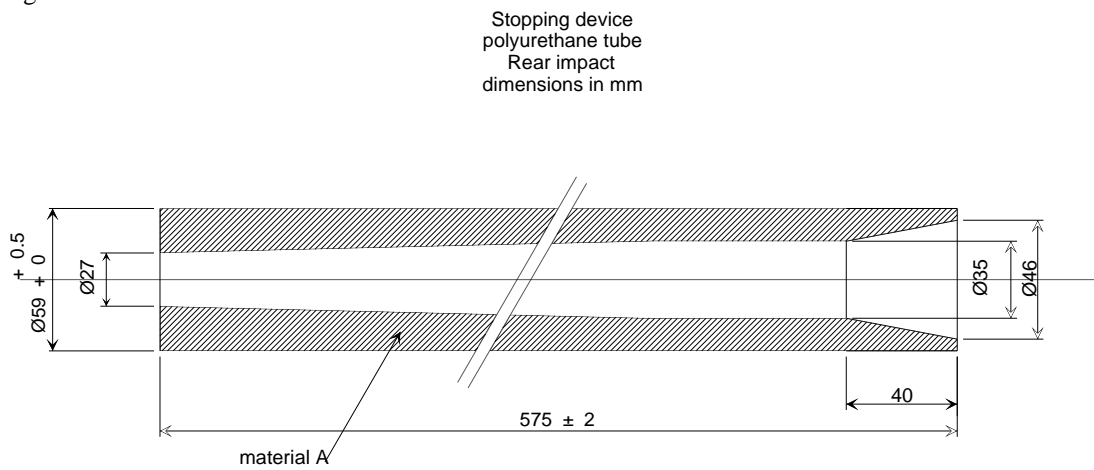

Figure 5



Annex 7

Curve of trolley's deceleration or acceleration, as function of time

In all cases the calibration and measuring procedures shall correspond to those defined in the International Standard ISO 6487; the measuring equipment shall correspond to the specification of a data channel with a channel frequency class (CFC) 60.

Annex 7 - Appendix 1

Frontal impact

Curve of trolley's deceleration or acceleration, as function of time

Frontal impact – Test pulse 1

<i>Definition of the different curves</i>		
<i>Time (ms)</i>	<i>Acceleration (g) Low corridor</i>	<i>Acceleration (g) High corridor</i>
0	-	10
20	0	-
50	20	28
65	20	-
+80	-	28
100	0	-
120	-	0

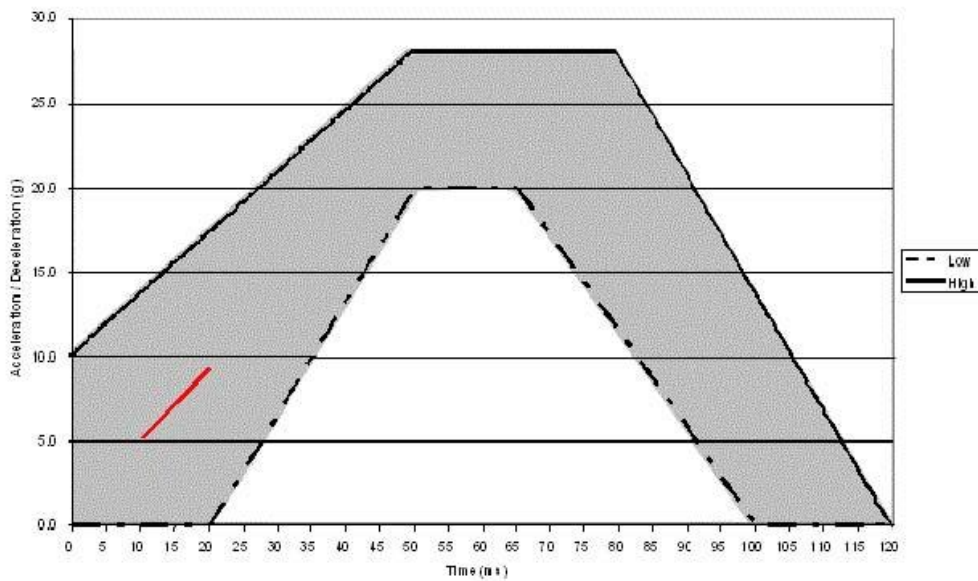

The additional segment applies only for the acceleration sled.

Annex 7 - Appendix 2

Rear impact

Curves of trolley's deceleration or acceleration, as function of time

Rear impact – Test pulse 2

<i>Definition of the different curves</i>		
<i>Time (ms)</i>	<i>Acceleration (g) Low corridor</i>	<i>Acceleration (g) High corridor</i>
0	-	21
10	0	
10	7	-
20	14	-
37	14	-
52	7	-
52	0	
70	-	21
70	-	0

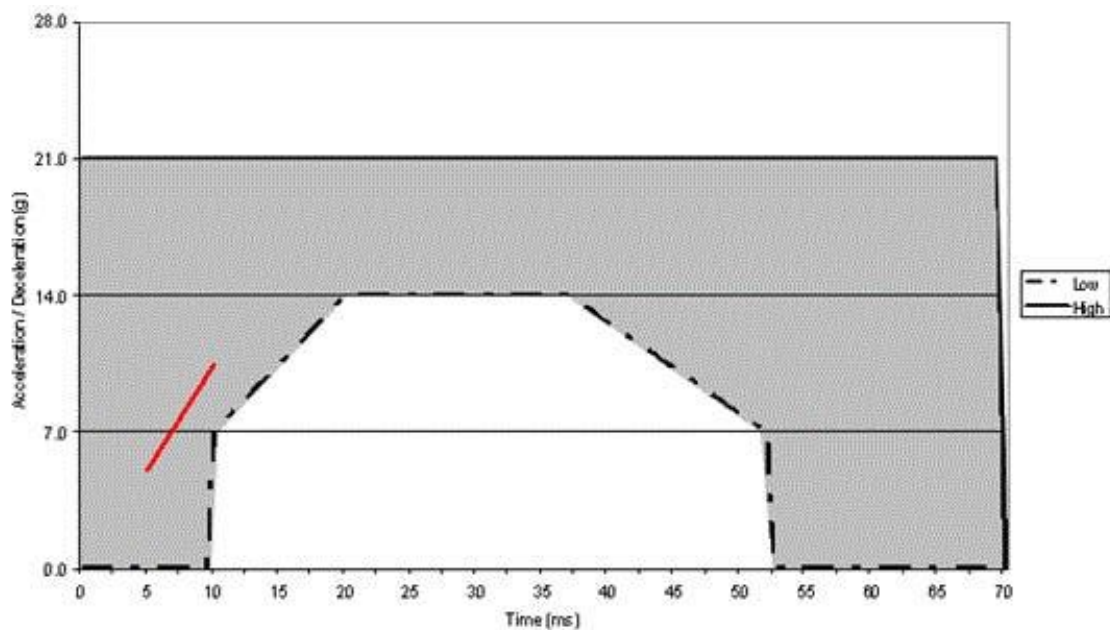

The additional segment applies only for the acceleration sled.

Annex 7 - Appendix 3

Lateral impact

Curve of relative velocity between trolley and door panel as function of time

Lateral impact – Test velocity corridor 3

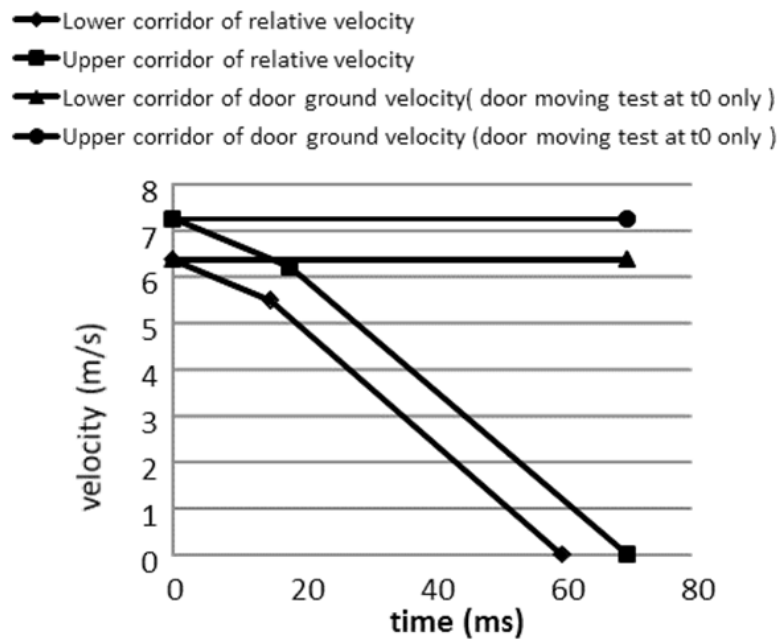

<i>Definition of the different curves</i>		
<i>Time (ms)</i>	<i>Relative door / bench velocity (m/s)</i>	
	<i>Lower corridor</i>	<i>Upper corridor</i>
0	6.375	7.25
15	5.5	-
18	-	6.2
60	0	-
70	-	0

Remark: The corridor shall be defined on experiences of respective test labs.

~~Annex 7 – Appendix 4~~

~~1. Door panel definition~~

~~The door panel geometry shall be in line with the bench definition.~~

~~Drawing to describe the door will be proposed in line with the NPACS bench.~~

~~2. Panel padding specification~~

~~2.1. General~~

~~The impacting surface of the door panel shall be entirely covered with a padding material 55 mm in thickness. The material shall comply with the performance criteria specified in paragraph 2.3. of this appendix when tested in accordance with paragraph 2.2. of this appendix.~~

~~A material combination that has been found to meet these requirements is detailed in paragraph 2.4. of this appendix.~~

~~2.2. Test procedure for the assessment of panel padding material~~

~~The test set up consists of a simple drop test using a spherical head form. The spherical head form has a diameter of 150 mm and a mass of 6 kg (± 0.1 kg). The impact speed is 4 m/s (± 0.1 m/s). The instrumentation should allow the assessment of the time of first contact between the impactor and the sample as well as the head form acceleration at least in direction of impact (Z direction).~~

~~The material sample should have the dimensions of 400 x 400 mm. The sample should be impacted in its centre.~~

~~2.3. Performance criteria for the padding material~~

~~The time of first contact between sample material and head form (t_0) is 0 ms.~~

~~The impactor acceleration shall not exceed 58 g.~~

Figure 1
Corridor for the padding material

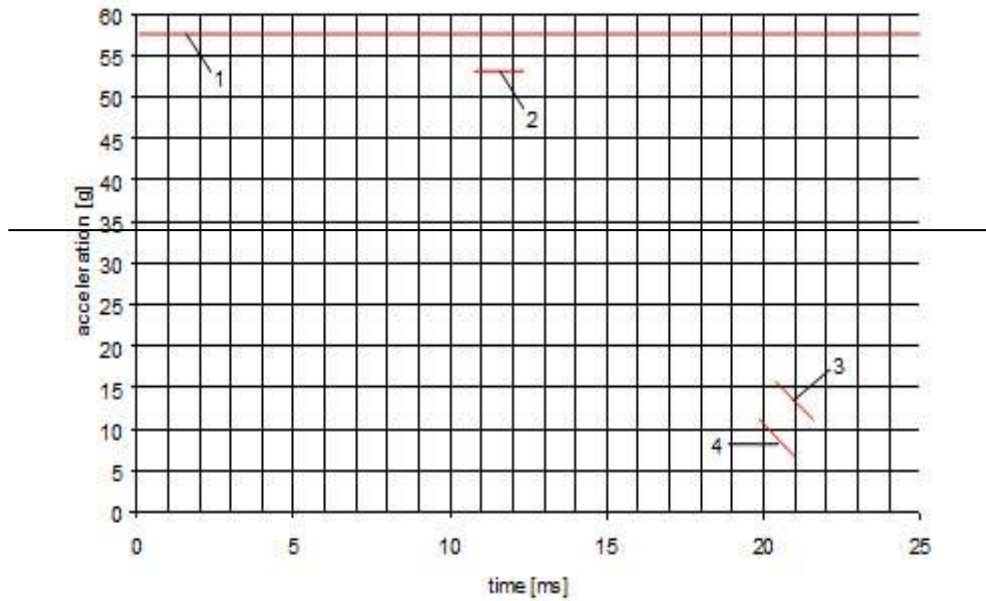

Key

- 1 Upper limit of 58 g
- 2 Lower limit for the maximum peak at 53 g (11 to 12 ms)
- 3 Upper limit for the decline of acceleration (15 g at 20,5 ms to 10 g at 21,5 ms)
- 4 Lower limit for the decline of acceleration (10 g at 20 ms to 7 g at 21 ms)

2.4. Example of material meeting the test requirements:

Rubber cell foam Polychloropren CR4271 measuring 35 mm in thickness attached to the door panel structure to which shall then be attached a subsequent layer of Styrodur C2500 20 mm in thickness. The Styrodur needs to be replaced after each test.

Annex 8

Description of dummies

1. General
 - 1.1. The dummies prescribed in this Regulation are described in this annex, in technical drawings held by Humanetics Innovative Solutions Inc. and in the user manuals delivered with the dummies.
 - 1.2. Alternative dummies may be used provided that:
 - 1.2.1. Their equivalence can be demonstrated to the satisfaction of the Type Approval Authority, and
 - 1.2.2. Their use is recorded in the test report, and in the communication form described in Annex 1 to this Regulation.
2. Description of the dummies
 - 2.1. The dimensions and masses of the Q0, Q1, Q1.5, Q3, Q6 and Q10 dummies described below are based on the anthropometry of 50th per centile children aged 0, 1, 1.5, 3, 6 and 10.5 years respectively.
 - 2.2. The dummies consist of a metal and plastic skeleton covered with plastic skinned foam parts to complete body components.
3. Construction
 - 3.1. Head

The head is largely made from synthetics. The head cavity is large enough to allow use of several instruments, including linear accelerometers and angular velocity sensors.
 - 3.2. Neck

The neck is flexible and allows shear and bending in all directions. The segmented design allows a realistic rotational behaviour. The neck is equipped with low stretch neck-cord in order to prevent excessive elongation. The neck-cord is also designed to act as a safety cord in case of rubber failure. A six channel load cell can be mounted at the neck-head and neck-torso interface. The Q0, Q1 and Q1.5 cannot accommodate the load cell between neck and torso.
 - 3.3. Thorax

The thorax of the child is represented by a single rib-cage. The deformation can be measured with a string potentiometer in Q1 and Q1.5 and an IR-TRACC sensors in Q3, Q6 and Q10. The shoulders are connected with a flexible joint to the thorax, allowing deformation forwards.
 - 3.4. Accelerometers can be mounted on the spine to measure linear accelerations. The Q0 thorax has a simplified layout with an integral foam part for the complete torso.
 - 3.5. Abdomen

The abdomen is foam covered with skin. Biomechanical data from children has been used to determine the required stiffness. The Q0 abdomen has a simplified layout with an integral foam part for the complete torso.

3.6. Lumbar spine

The lumbar spine is a flexible rubber column, which allows shear and bending in all directions. A six channel load cell can be mounted between the lumbar spine and the pelvis, except for the Q0.

3.7. Pelvis

The pelvis is constructed from an iliac-sacrum bone part covered with a plastic flesh outer contour simulation. In the bone part removable hip joints are inserted. An accelerometer array can be mounted in the pelvis. Special hip joints are available that allow to position the dummy in a standing position. The Q0 pelvis has a simplified layout with an integral foam part for the complete torso.

3.8. Legs

The legs are constructed with metal reinforced plastic bones cover with PVC skinned foam parts that represent the upper and lower flesh. The knee joints can be locked in any position. This feature can be used to facilitate positioning the dummy in a standing position. (Note that the dummy does not have the ability to stand without external support.) The Q0 legs have a simplified layout with one integral part per leg with a fixed angle at the knee.

3.9. Arms

The arms are constructed with plastic bones cover with PVC skinned foam parts that represent the upper and lower flesh. The elbow joints can be locked in any position. The Q0 arms have a simplified layout with one integral part per arm with a fixed angle at the elbow.

4. Main characteristics

4.1. Mass

Table 1
Q-dummy mass distributions

	Q0	Q1	Q1.5	Q3	Q6	Q10 Design targets
<i>Mass in [kg]</i>						
Head + Neck (incl. acc. mount)	1.10 ± 0.10	2.41 ± 0.10	2.80 ± 0.10	3.17 ± 0.10	3.94 ± 0.10	4.19
Torso (incl. acc. mount and chest deflection sensor)	1.50 ± 0.15	4.21 ± 0.25	4.74 ± 0.25	6.00 ± 0.30	9.07 ± 0.40	14.85 (incl. suit)
Legs (together)	0.58 ± 0.06	1.82 ± 0.20	2.06 ± 0.20	3.54 ± 0.10	6.90 ± 0.10	12.50
Arms (together)	0.28 ± 0.03	0.89 ± 0.20	1.20 ± 0.20	1.48 ± 0.10	2.49 ± 0.10	4.00
Suit	0.27 ± 0.05	0.27 ± 0.05	0.30 ± 0.05	0.40 ± 0.10	0.55 ± 0.10	(see torso)
Total	3.73 ± 0.39	9.6 ± 0.80	11.10 ± 0.80	14.59 ± 0.70	22.95 ± 0.80	35.54

4.2. Principal dimensions

Figure 2

Main dimensions of dummy

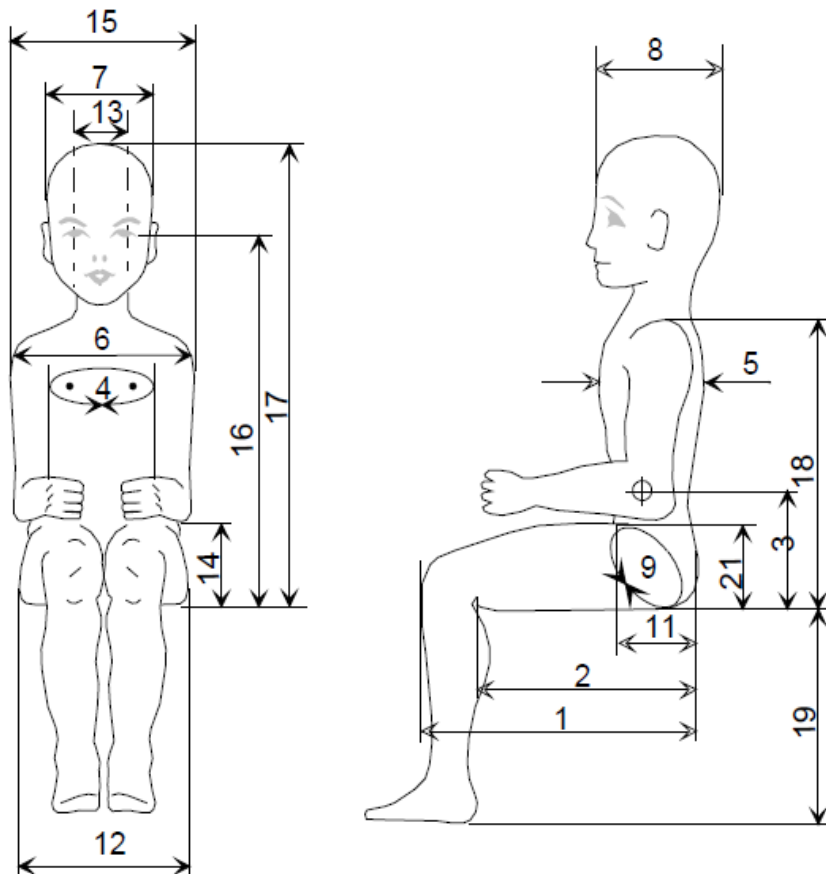

Table 2
Q-dummy dimensions

No.		Q0	Q1	Q1.5	Q3	Q6	Q10 (design targets)
		<i>Dimensions in mm</i>					
17	Seating height (head tilted forward)	355 ± 9	479 ± 9	499 ± 9	544 ± 9	601 ± 9	< 748 ± 9
18	Shoulder height (sitting)	225 ± 7	298 ± 7	309 ± 7	329 ± 7	362 ± 7	473 ± 7
	Stature (head tilted forward)	-	740 ± 9	800 ± 9	985 ± 9	1143 ± 9	< 1443 ± 9
5	Chest depth	-	114 ± 5	113 ± 5	146 ± 5	141 ± 5	171 ± 5
15	Shoulder width	230 ± 7	227 ± 7	227 ± 7	259 ± 7	305 ± 7	338 ± 7
13	Neck diameter	44	61.9¹	61.9¹	61.9¹	61.9² 58.0³ 76.0⁴	65.0¹ 85.9⁴
12	Hip width	-	191 ± 7	194 ± 7	200 ± 7	223 ± 7	270 ± 7
1	Back of buttocks to front of knees	130 ± 5	211 ± 5	235 ± 5	305 ± 5	366 ± 5	488 ± 5
2	Back of buttocks to popliteus	-	161 ± 5	185 ± 5	253 ± 5	299 ± 5	418 ± 5
21	Thigh height, sitting		69	72	79	92	114
	Height of spacer device for positioning of dummy ⁵		229 ± 2	237 ± 2	250 ± 2	270 ± 2	359 ± 2

⁺ See section 7.1.3.5.2.1: Height of spacer device (hinged board or similar flexible device) equals shoulder height sitting minus thigh height sitting.

Notes:

- Adjustments of joints

Joints should be adjusted according to procedures included in the Q-dummy manuals⁶

¹ The neck diameter is taken as the diameter of the top and bottom plate of the Q dummy necks. Middle disks are 56,9 mm

² Q6 neck disk at top

³ Q6 neck disk at bottom

⁴ Neck shield diameter

⁵ See paragraph 7.1.3.5.2.1: Height of spacer device (hinged board or similar flexible device) equals shoulder height sitting minus thigh height sitting.

2. Instrumentation

Instrumentation in the Q family of dummies shall be installed and calibrated according to procedures contained in the Q-dummy manuals²

⁶ The technical specifications and detailed drawings of Q-dummy, and the technical specifications for their adjustment for the tests of this Regulation are deposited in a transitory way on the website of the informal working group on **Enhanced** Child Restraint Systems (www2.unece.org/wiki/display/trans/Q-dummy+drawings) of the UNECE, Palais de Nations, Geneva, Switzerland. At the time of the adoption of this Regulation by the World Forum for Harmonization of Vehicle Regulations (WP.29), the text restricting the use of the drawings and technical specifications will be removed from the individual pages and they will be reloaded on the above-mentioned website. After a time period needed by the Informal Working Group to finalize the examination of the technical specifications and drawings of dummies to cover the phase 2 of the Regulation, the final and agreed drawings will be relocated in the Mutual Resolution of the 1958 and 1998 Agreements, hosted in the website of the World Forum WP.29.

Annex 9

Frontal impact test against a barrier

- 1.1. Testing ground

The test area shall be large enough to accommodate the run-up track, barrier and technical installations necessary for the test. The last part of the track, for at least 5 m before the barrier, shall be horizontal, flat and smooth.
- 1.2. Barrier

The barrier consists of a block of reinforced concrete not less than 3 m wide at the front and not less than 1.5 m high. The barrier shall be of such thickness that it weighs at least 70 tonnes. The front face shall be vertical, perpendicular to the axis of the run-up track, and covered with plywood boards 20 ± 1 mm thick in good condition. The barrier shall be either anchored in the ground or placed on the ground with, if necessary, additional arresting devices to limit its displacement. A barrier with different characteristics, but giving results at least equally conclusive, may likewise be used.
- 1.3. Propulsion of the vehicle

At the moment of impact, the vehicle shall no longer be subjected to the action of any additional steering or propelling device or devices. It shall reach the obstacle on a course perpendicular to the collision wall; the maximum lateral disalignment permitted between the vertical median line of the front of the vehicle and the vertical median line of the collision wall is ± 30 cm.
- 1.4. State of the vehicle
 - 1.4.1. The vehicle under test shall either be fitted with all the normal components and equipment included in its unladen service weight or be in such a condition as to fulfil this requirement in so far as the components and equipment of concern to the passenger compartment and the distribution of the service weight of the vehicle as a whole are concerned.
 - 1.4.2. If the vehicle is driven by external means, the fuel installation shall be filled to at least 90 per cent of its capacity, either with fuel or with a non-inflammable liquid, having a density and a viscosity close to those of the fuel normally used. All other systems (brake-fluid containers, radiator, etc.) shall be empty.
 - 1.4.3. If the vehicle is driven by its own engine, the fuel tank shall be at least 90 per cent full. All other liquid-holding tanks shall be filled to capacity.
 - 1.4.4. If the manufacturer so requests, the Technical Service responsible for conducting the tests may allow the same vehicle as is used for tests prescribed by other Regulations (including tests capable of affecting its structure) to be used also for the tests prescribed by this Regulation.
- 1.5. Impact velocity

The impact velocity shall be $50 +0/-2$ km/h. However, if the test has been carried out at a higher impact velocity and the vehicle has satisfied the conditions prescribed, the test is considered satisfactory.

1.6. Measuring instruments

The instrument used to record the speed referred to in paragraph 1.5. above shall be accurate within 1 per cent.

Annex 10

Rear impact test procedure

1. Installations, procedures and measuring instruments
 - 1.1. Testing ground

The test area shall be large enough to accommodate the propulsion system of the impactor and to permit after-impact displacement of the vehicle impacted and installation of the test equipment. The part in which vehicle impact and displacement occur shall be horizontal. (The slope shall be less than 3 per cent measured over any length of one metre.)
 - 1.2. Impactor
 - 1.2.1. The impactor shall be of steel and of rigid construction.
 - 1.2.2. The impacting surface shall be flat and at least 2,500 mm wide and 800 mm high. Its edges shall be rounded to a radius of curvature of between 40 and 50 mm. It shall be clad with a layer of plywood 20 ± 1 mm thick.
 - 1.2.3. At the moment of impact the following requirements shall be met:
 - 1.2.3.1. The impacting surface shall be vertical and perpendicular to the median longitudinal plane of the impacted vehicle;
 - 1.2.3.2. The direction of movement of the impactor shall be substantially horizontal and parallel to the median longitudinal plane of the impacted vehicle;
 - 1.2.3.3. The maximum lateral deviation permitted between the median vertical line of the surface of the impactor and the median longitudinal plane of the impacted vehicle shall be 300 mm. In addition, the impacting surface shall extend over the entire width of the impacted vehicle;
 - 1.2.3.4. The ground clearance of the lower edge of the impacting surface shall be 175 ± 25 mm.
 - 1.3. Propulsion of the impactor

The impactor may either be secured to a carriage (moving barrier) or form part of a pendulum.
 - 1.4. Special provisions applicable where a moving barrier is used
 - 1.4.1. If the impactor is secured to a carriage (moving barrier) by a restraining element, the latter shall be rigid and be incapable of being deformed by the impact; the carriage shall, at the moment of impact, be capable of moving freely and no longer be subject to the action of the propelling device.
 - 1.4.2. The combined mass of carriage and impactor shall be $1,100 \pm 20$ kg.
 - 1.5. Special provisions applicable where a pendulum is used
 - 1.5.1. The distance between the centre of the impacting surface and the axis of rotation of the pendulum shall be not less than 5 m.
 - 1.5.2. The impactor shall be freely suspended by rigid arms, rigidly secured to it. The pendulum so constituted shall be substantially incapable of being deformed by the impact.

- 1.5.3. A stopping device shall be incorporated in the pendulum to prevent any secondary impact by the impactor on the test vehicle.
- 1.5.4. At the moment of impact, the velocity of the centre of percussion of the pendulum shall be between 30 and 32 km/h.
- 1.5.5. The reduced mass " m_r " at the centre of percussion of the pendulum is defined as a function of the total mass " m ", of the distance " a "¹ between the centre of percussion and the axis of rotation, and of the distance " l " between the centre of gravity and the axis of rotation, by the following equation:

$$m_r = m \cdot \frac{l}{a}$$

- 1.5.6. The reduced mass " m_r " shall be $1,100 \pm 20$ kg.
- 1.6. General provisions relating to the mass and velocity of the impactor
If the test has been conducted at an impact velocity higher than those prescribed in paragraph 1.5.4. above and/or with a mass greater than those prescribed in paragraphs 1.5.3. or 1.5.6. above, and the vehicle has met the requirements prescribed, the test shall be considered satisfactory.
- 1.7. State of the vehicle during the test
The vehicle being tested shall either be fitted with all the normal components and equipment included in its unladen service weight or be in such condition as to fulfil this requirement in so far as the distribution of the service weight of the vehicle as a whole is concerned.
- 1.8. The complete vehicle with the **Enhanced** Child Restraint System installed in accordance with the fitting instructions shall be placed on a hard, flat and level surface, with the handbrake off and in neutral gear. More than one **Enhanced** Child Restraint System may be tested in the same impact test.

¹ The distance " a " is equal to the length of the synchronous pendulum under consideration.

Annex 11

Type approval scheme (Flow chart ISO 9002:2000)

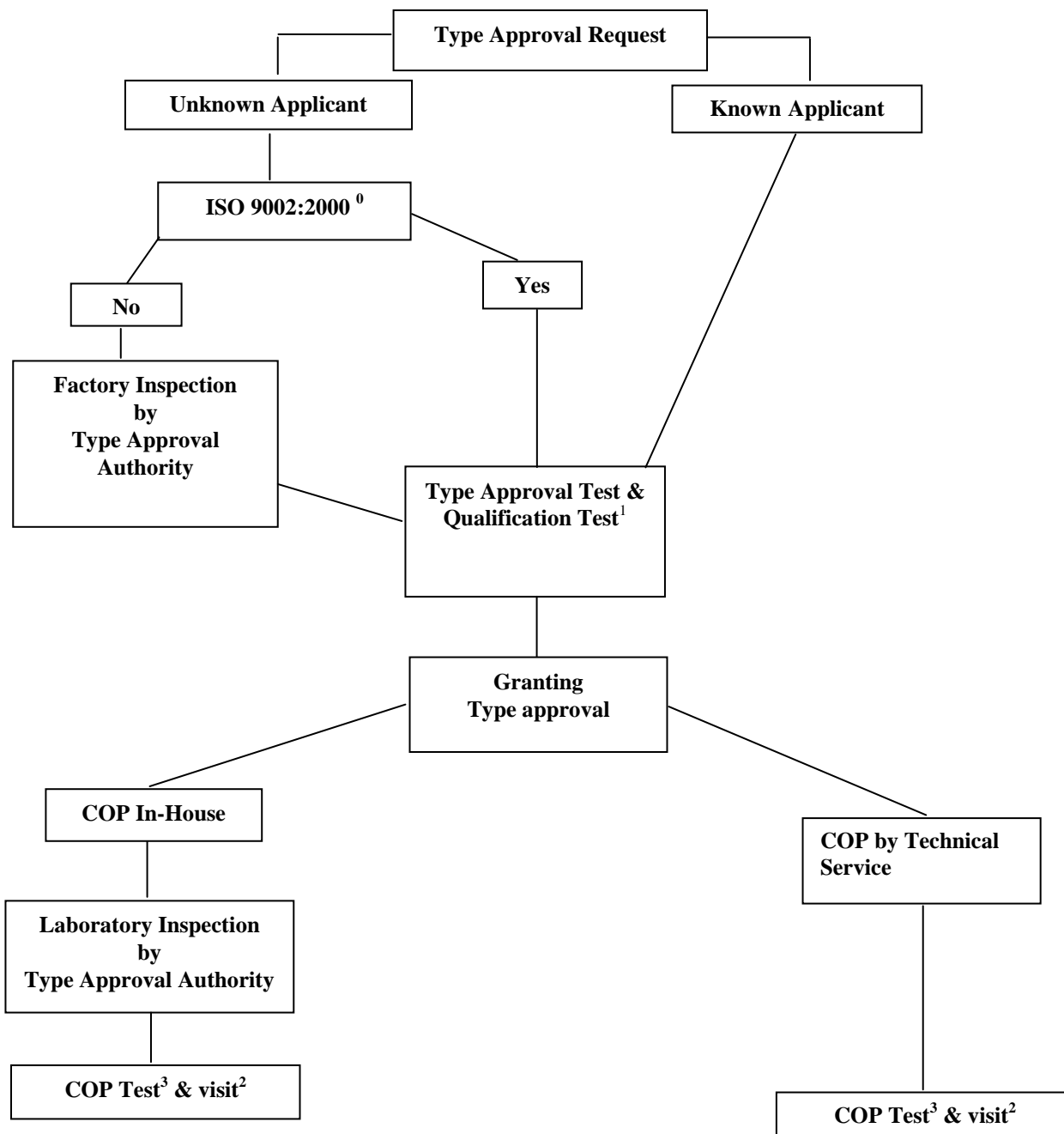

Notes:

0. Or an equivalent standard to this one with the permissible exclusion of the requirements related to the concepts of design and development; point 7.3. of ISO 9002:2000 "Customer satisfaction and continual improvement"
1. These tests shall be done by Technical Services
2. Visit to the manufacturer for inspection and random sampling by the Type Approval Authority or Technical Service
 - (a) If there is no ISO 9002:2000: 2 times a year;
 - (b) If there is an ISO 9002:2000: 1 time a year.
3. Tests in accordance with Annex 13
 - (a) If there is no ISO 9002:2000:
 - (i) Of the Type Approval Authority or Technical Service during the visit of footnote 2a above;
 - (ii) Of the manufacturer between the visits of footnote 2b above;
 - (b) If there is an ISO 9002:2000: taken by the manufacturer, procedure checked during visit of footnote 2b above.

Annex 12

Control of conformity of production

1. Tests

Enhanced Child Restraint Systems shall be required to demonstrate compliance with the requirements on which the following tests are based:
- 1.1. Verification of the locking threshold and durability of emergency locking retractors

According to the provisions of paragraph 7.2.4.3. of this Regulation in the most unfavourable direction as appropriate after having undergone the durability testing detailed in paragraphs 7.2.4.2., 7.2.4.4. and 7.2.4.5. of this Regulation as a requirement of paragraph 6.7.3.2.6. of this Regulation.
- 1.2. Verification of the durability of automatically locking retractors

According to the provisions of paragraph 7.2.4.2. of this Regulation supplemented by the tests in paragraphs 7.2.4.4. and 7.2.4.5. of this Regulation as a requirement of paragraph 6.7.3.1.3. of this Regulation.
- 1.3. Test for strength of straps after conditioning

According to the procedure described in paragraph 6.7.4.2. of this Regulation after conditioning according to the requirements of paragraphs 7.2.5.2.1. to 7.2.5.2.5. of this Regulation.
- 1.3.1. Test for strength of straps after abrasion

According to the procedure described in paragraph 6.7.4.2. of this Regulation after conditioning according to the requirements described in paragraph 7.2.5.2.6. of this Regulation.
- 1.4. Microslip test

According to the procedure described in paragraph 7.2.3. of this Regulation.
- 1.5. Energy absorption

According to the provisions of paragraph 6.6.2. of this Regulation.
- 1.6. Verification of the performance requirements of the **Enhanced** Child Restraint System when subjected to the appropriate dynamic test:

According to the provisions set out in paragraph 7.1.3. of this Regulation with any buckle having been pre-conditioned according to the requirements of paragraph 6.7.1.6. of this Regulation such that the appropriate requirements of paragraph 6.6.4. of this Regulation (for the overall performance of the **Enhanced** Child Restraint System) and paragraph 6.7.1.7.1. of this Regulation (for the performance of any buckle under load) are complied with.
- 1.7. Temperature test

According to the provisions of paragraph 6.6.5. of this Regulation.

2. Test frequency and results
- 2.1. The frequency of testing to the requirements of paragraphs 1.1. to 1.5. and 1.7. above shall be on a statistically controlled and random basis in accordance with one of the regular quality assurance procedure, and shall be conducted at least once per year.
- 2.2. Minimum conditions for the control of conformity of **Enhanced** Child Restraint Systems of category Universal, "~~Semi Universal~~" and "~~Restricted~~", in relation to the dynamic tests according to paragraph 1.6. above.
- In accordance with the relevant authorities, the holder of an approval will supervise the control of conformity following the method of batch control (para. 2.2.1. below) or following the method of continuous control (para. 2.2.2. below).
- 2.2.1. Batch control for the **Enhanced** Child Restraint Systems
- 2.2.1.1. The holder of an approval shall divide the **Enhanced** Child Restraint Systems into batches which are as uniform as possible in regard to raw material or intermediate products involved in their manufacture (different colour of shell, different manufacture of harness) and in regard to production conditions. The numbers in a batch shall not exceed 5,000 units.
- In agreement with the relevant authorities the tests can be carried out by the Technical Service or under the responsibility of the holder of an approval.
- 2.2.1.2. A sample shall be taken in each batch in accordance with the provisions of paragraph 2.2.1.4. below from a minimum of 20 per cent of the batch quantity, which has to be produced of the actual batch.
- 2.2.1.3. The characteristics of the **Enhanced** Child Restraint Systems and the number of dynamic tests to be conducted are given in paragraph 2.2.1.4. below
- 2.2.1.4. In order to be accepted, a batch of **Enhanced** Child Restraint Systems shall satisfy the following conditions.

<i>Number in the batch</i>	<i>Number of samples/ Enhanced Child Restraint Systems characteristics</i>	<i>Combined number of samples</i>	<i>Acceptance criteria</i>	<i>Rejection criteria</i>	<i>Degree of control rigour</i>
N<500	1st = 1MH	1	0	-	Normal
	2nd = 1MH	2	1	2	
500<N<5,000	1st = 1MH+1LH	2	0	2	Normal
	2nd = 1MH+1LH	4	1	2	
N<500	1st = 2MH	2	0	2	Strengthened
	2nd = 2MH	4	1	2	
500<N<5,000	1st = 2MH+2LH	4	0	2	Strengthened
	2nd = 2MH+2LH	8	1	2	

Notes:

MH means harder configuration (the least good results obtained in approval or extension of approval)
LH signifies a less hard configuration.

This dual sampling plan functions as follows:

For a normal control, if the first sample does not contain any defective units the batch is accepted without testing a second sample. If it contains two defective units the batch is rejected. Finally, if it contains one defective unit a second sample is extracted and it is the cumulative number, which shall satisfy the condition of column 5 of the table above.

There is a change from normal control to strengthened control if, out of 5 consecutive batches, two are rejected. Normal control is resumed if 5 consecutive batches are accepted.

If any batch is rejected, the production is considered to be non-conforming and the batch shall not be released.

If two consecutive batches subjected to the strengthened control are rejected, the provisions of paragraph 13. of this Regulation are applied.

2.2.1.5. The control of **Enhanced** Child Restraint Systems conformity is undertaken starting with the batch manufactured after the first batch which was subjected to production qualification.

2.2.1.6. The test results described in paragraph 2.2.1.4. above shall not exceed L, where L is the limit value prescribed for each approval test.

2.2.2. Continuous control

2.2.2.1. The holder of an approval shall be obliged to carry out continuous quality control of his manufacturing process on a statistical basis and by sampling. In agreement with the relevant authorities, the tests can be carried out by the Technical Service or under the responsibility of the holder of an approval which is responsible for the traceability of the product.

2.2.2.2. The samples shall be taken in accordance with the provisions of paragraph 2.2.2.4. below.

2.2.2.3. The characteristic of the **Enhanced** Child Restraint Systems is taken at random and the tests to be carried out are described in paragraph 2.2.2.4. below.

2.2.2.4. Control shall meet the following requirements:

<i>Enhanced Child Restraint Systems taken</i>	<i>Degree of control rigour</i>
0.02 per cent means one Enhanced Child Restraint System taken from every 5,000 manufactured	Normal
0.05 per cent means one Enhanced Child Restraint System taken from every 2,000 manufactured	Strengthened

This dual sampling plan functions as follows:

If the **Enhanced** Child Restraint System is considered to conform, the production conforms.

If the **Enhanced** Child Restraint System does not meet the requirements, a second **Enhanced** Child Restraint System shall be taken.

If the second **Enhanced** Child Restraint System meets the requirements, the production conforms.

If both (the first and the second) **Enhanced** Child Restraint Systems do not meet the requirements, the production does not conform and **Enhanced** Child Restraint Systems that are likely to present the same failure shall be withdrawn and necessary steps shall be taken to re-establish the conformity of the production.

Strengthened control will replace normal control if, out of 10,000 **Enhanced** Child Restraint Systems manufactured consecutively, the production has to be withdrawn twice.

Normal control is resumed if 10,000 **Enhanced** Child Restraint Systems manufactured consecutively are considered to conform.

If production subjected to the strengthened control has been withdrawn on two consecutive occasions, the provisions of paragraph 13. of this Regulation are applied.

- 2.2.2.5. The continuous control of **Enhanced** Child Restraint Systems is undertaken starting after the production qualification.
- 2.2.2.6. The test results described in paragraph 2.2.2.4. above shall not exceed L, where L is the limit value prescribed for each approval test.
- 2.3. For "Specific vehicle **ECRS** ~~ISOFIX~~" devices according to paragraph 2.1.2.4.1. above, the **Enhanced** Child Restraint System manufacturer may choose Conformity of Production procedures according to either paragraph 2.2. above, on a test bench, or paragraphs 2.3.1. and 2.3.2. below, in a vehicle body shell.
- 2.3.1. For "Specific vehicle ~~ISOFIX~~ **ECRS**" devices, the following test frequencies shall apply once every eight weeks:
- At each test all requirements according to paragraphs 6.6.4. and 6.7.1.7.1. of this Regulation shall be fulfilled. If all tests during one year show satisfactory results, the manufacturer may, after agreement with the Type Approval Authority, reduce the frequencies as follows: once every 16 weeks.
- However, a minimum frequency of one test per year shall be permitted where annual production is 1,000 **Enhanced** Child Restraint Systems or less.
- 2.3.2. Where a test sample fails a particular test to which it has been subjected, a further test to the same requirement shall be carried out on at least three other samples. In the case of dynamic tests if one of the latter fails, the production is considered to be non-conforming and the frequency shall be raised to the higher one if the lower one was used according to paragraph 2.3. above and necessary steps shall be taken to re-establish the conformity of the production.
- 2.4. When production is found to be non-conforming according to paragraphs 2.2.1.4., 2.2.2.4. or 2.3.2. above, the holder of the approval or his duly accredited representative shall:
- 2.4.1. Notify the Type Approval Authority which has granted type approval indicating what steps have been taken to re-establish the conformity of production.
- 2.5. The manufacturer shall advise the Type Approval Authority on a quarterly basis, the volume of products produced against each approval number,

providing a means of identifying which products correspond to that approval number.

Annex 13

Test of energy absorbing material

1. Headform
 - 1.1. The headform shall consist of a solid wooden hemisphere with an added smaller spherical segment as shown in Figure A below. It shall be constructed so that it can be dropped freely along the axis marked and it shall have provision for mounting an accelerometer in order to measure the acceleration along the direction of fall.
 - 1.2. The headform shall have a total mass, including the accelerometer of 2.75 ± 0.05 kg.

Figure A
Headform

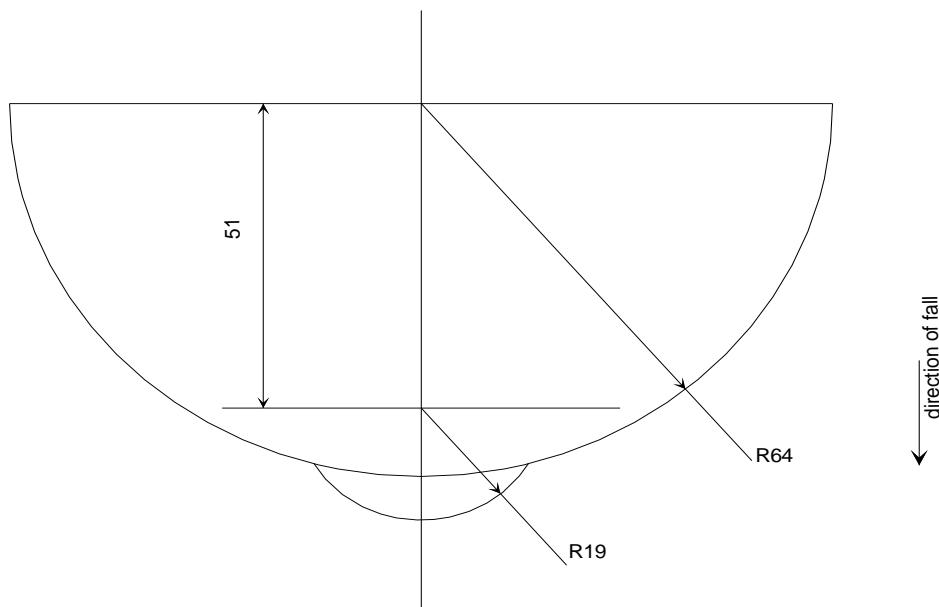

2. Instrumentation

The acceleration shall be recorded during the test, using equipment in accordance with channel frequency class 1000 as specified in the latest version of ISO 6487.
3. Procedure
 - 3.1. The **Enhanced Child Restraint System** shall be placed in the region of impact on a rigid flat surface, whose minimum dimensions are 500x 500 mm, so that the direction of impact is perpendicular to the inner surface of the restraint system in the area of impact
 - 3.2. Raise the headform to a height of 100 $-0/+5$ mm from the respective upper surfaces of the assembled **Enhanced Child Restraint System** to the lowest point on the headform, and allow it to fall. Record the acceleration experienced by the headform during impact.

Annex 14

Method of defining head impact area of devices with backrests and for rearward-facing devices defining the minimum size of side wings

1. Place the device on the test **bench** described in Annex 6. Reclinable devices shall be set in the most upright position. Place the smallest manikin in the device in accordance with the manufacturer's instructions. Mark a point "A" on the backrest on the same horizontal level as the shoulder of the smallest manikin at a point 2 cm inside the outer edge of the arm. All internal surfaces above the horizontal plane passing through point A, shall be tested in accordance with Annex 13. This area shall include the backrest and side wings, including the inner edges (zone of radius) of the side wings. In the case of carrycot devices where a symmetrical installation of the dummy is not possible according to the device and manufacturer instructions, the area complying with Annex 13 shall be all internal surfaces above a point "A", as previously defined, in the head direction, when measured with this dummy in the carrycot in its worst position consistent with the manufacturer instructions and the carrycot positioned on the test bench.

If a symmetrical installation of the dummy in the carrycot may be possible, the whole inner area shall comply with Annex 13.

2. For rearward-facing devices there shall be side wings with a depth of minimum 90 mm measured from the median of the surface of the backrest. These side wings shall start at the horizontal plane passing through point "A" and continue to the top of the **Enhanced** Child Restraint System seat-back. Starting from a point 90 mm below the top of the **Enhanced** Child Restraint System seat-back, the depth of the side wing may be gradually reduced.

Annex 15

Description of conditioning of adjusters mounted directly on Enhanced Child Restraint Systems

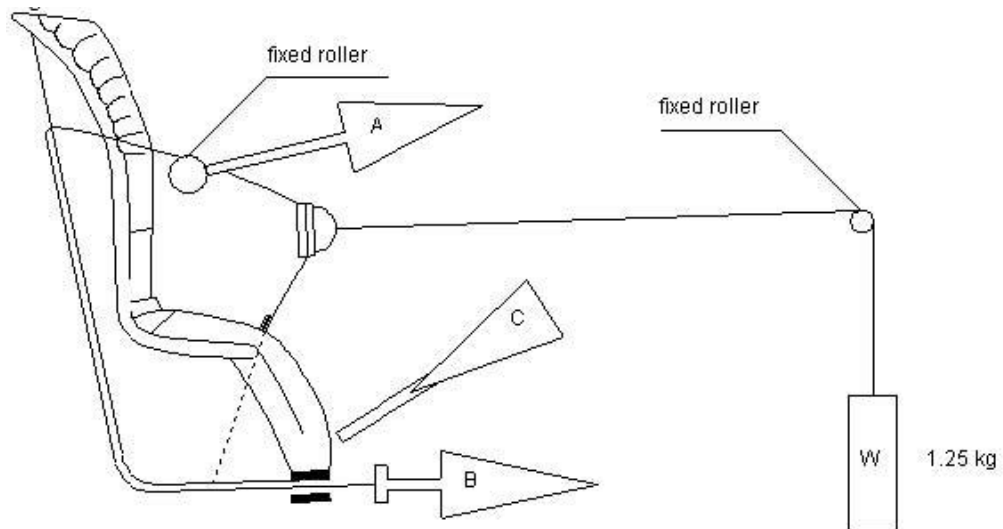
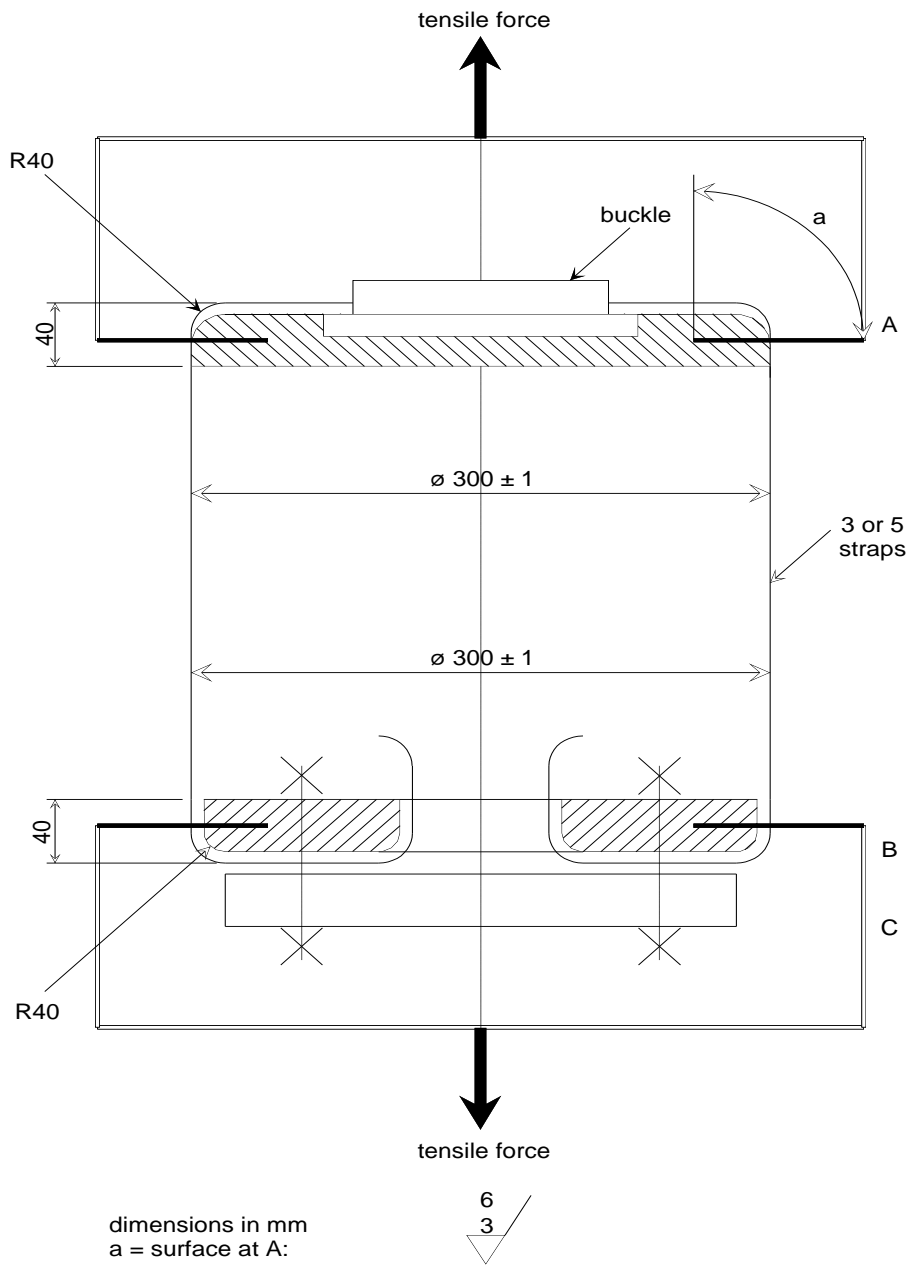

Figure 1

1. Method
 - 1.1. With the webbing set at the reference position described in paragraph 7.2.6., withdraw at least 50 mm of webbing from the integral harness by pulling on the free end of the webbing.
 - 1.2. Attach the adjusted part of the integral harness to the pulling device A.
 - 1.3. Activate the adjuster and pull at least 150 mm of webbing into the integral harness. This represents half of one cycle and puts pulling device A to the maximum webbing extraction position.
 - 1.4. Connect free end of webbing to pulling device B.
2. The cycle is:
 - 2.1. Pull B at least 150 mm whilst A exerts no tension on the integral harness.
 - 2.2. Activate the adjusters and pull A whilst B exerts no tension on the free end of the webbing.
 - 2.3. At the end of stroke, de-activate the adjuster.
 - 2.4. Repeat cycle as specified in paragraph 6.7.2.7. of this Regulation.

Annex 16

Typical buckle strength test device



Annex 17

Determination of performance criteria

1. Head Performance Criterion (HPC)
 - 1.1. This criterion is considered to be satisfied when, during the test, there is no contact between the head and any vehicle component.
 - 1.2. If that is not the case, a calculation of the value of HPC is made, on the basis of the acceleration (a),¹ by the following expression:

$$\text{HPC} = (t_2 - t_1) \left[\frac{1}{t_2 - t_1} \int_{t_1}^{t_2} a dt \right]^{2.5}$$

In which:

- 1.2.1. The term "a" is the resultant acceleration is measured in units of gravity, g (1 g = 9,81 m/s²);
- 1.2.2. If the beginning of the head contact can be determined satisfactorily, t₁ and t₂ are the two time instants, expressed in seconds, defining an interval between the beginning of the head contact and the end of the recording for which the value of HPC is maximum;
- 1.2.3. If the beginning of the head contact cannot be determined, t₁ and t₂ are the two time instants, expressed in seconds, defining a time interval between the beginning and the end of the recording for which the value of HPC is maximum;
- 1.2.4. Values of HPC for which the time interval (t₁ - t₂) is greater than ~~36~~ **15** ms are ignored for the purposes of calculating the maximum value.
- 1.3. The value of the resultant head acceleration during forward impact which is exceeded for 3 ms cumulatively is calculated from the resultant head acceleration.

¹ The acceleration (a) referring to the centre of gravity is calculated from the triaxial components of the acceleration measured with a CFC of 1,000.

Annex 18

Geometrical dimensions of i-Size Enhanced Child Restraint Systems

Figure 1

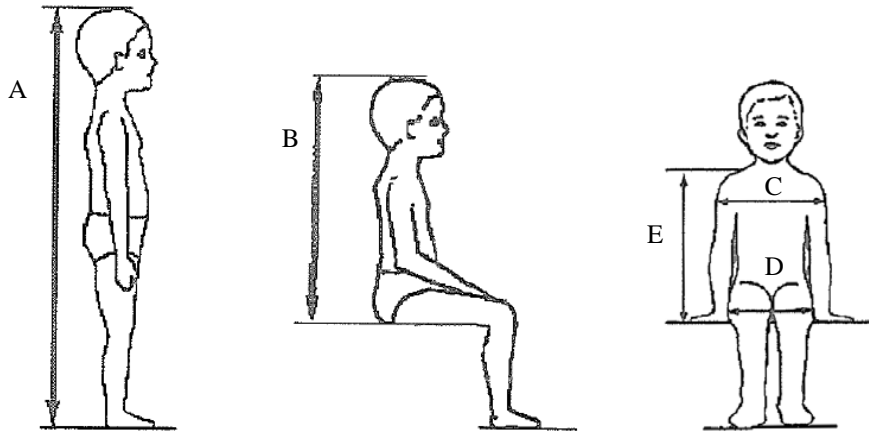

<i>Stature cm</i>	<i>Sitting height cm</i>	<i>Shoulder breadth cm</i>	<i>Hip breadth cm</i>	<i>Shoulder height cm</i>	
<i>A</i>	<i>B</i>	<i>C</i>	<i>D</i>	<i>E</i>	
	<i>95%ile</i>	<i>95%ile</i>	<i>95%ile</i>	<i>5%ile</i>	<i>95%ile</i>
40	NA	NA	NA	NA	NA
45	39.0	12.1	14.2	27.4	29.0
50	40.5	14.1	14.8	27.6	29.2
55	42.0	16.1	15.4	27.8	29.4
60	43.5	18.1	16.0	28.0	29.6
65	45.0	20.1	17.2	28.2	29.8
70	47.1	22.1	18.4	28.3	30.0
75	49.2	24.1	19.6	28.4	31.3
80	51.3	26.1	20.8	29.2	32.6
85	53.4	26.9	22.0	30.0	33.9
90	55.5	27.7	22.5	30.8	35.2
95	57.6	28.5	23.0	31.6	36.5
100	59.7	29.3	23.5	32.4	37.8
105	61.8	30.1	24.9	33.2	39.1
110	63.9	30.9	26.3	34.0	40.4
115	66.0	32.1	27.7	35.5	41.7
120	68.1	33.3	29.1	37.0	43.0
125	70.2	34.5	30.5	38.5	44.3
130	72.3	35.7	31.9	40.0	46.1
135	74.4	36.9	33.3	41.5	47.9
140	76.5	38.1	34.7	43.0	49.7
145	78.6	39.3	36.3	44.5	51.5
150	81.1	41.5	37.9	46.3	53.3

When measured under a contact force of 50 N with the device described in Figure 2 of this annex the following tolerances will be applied to the dimensions:

Minimum Sitting height:

- From 40 to 87 cm B - **5 per cent**
- From 87 cm and up B - **10 per cent,**

Minimum shoulder breadth: C $_{-0}^{+2}$ cm

Minimum hip breadth: D $_{-0}^{+2}$ cm

Minimum shoulder height (5 percentile): E1 $_{-2}^{+0}$ cm

Maximum shoulder height (95 percentile): E2 $_{-0}^{+2}$ cm

The mass of the device described in Figure 2 of this annex must be 10 kg +/- 1 kg

Figure 2
Side and front view of the measuring device

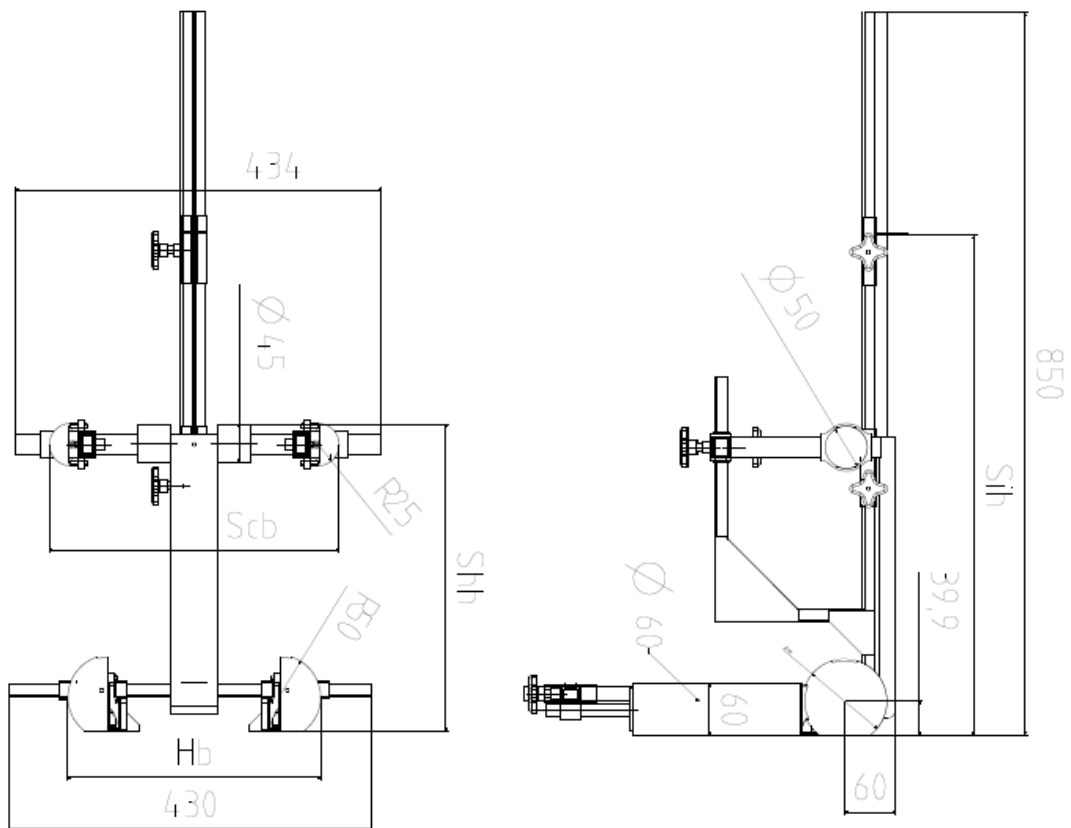

Notes:

- Hb: Hip breadth variable from 140 to 380 mm
- Scb : Shoulder breadth variable from 120 to 400 mm
- Sih : Sitting height variable from 400 to 800 mm
- Shh : Shoulder height variable from 270 to 540 mm

Figure 3
3D view of the measuring device

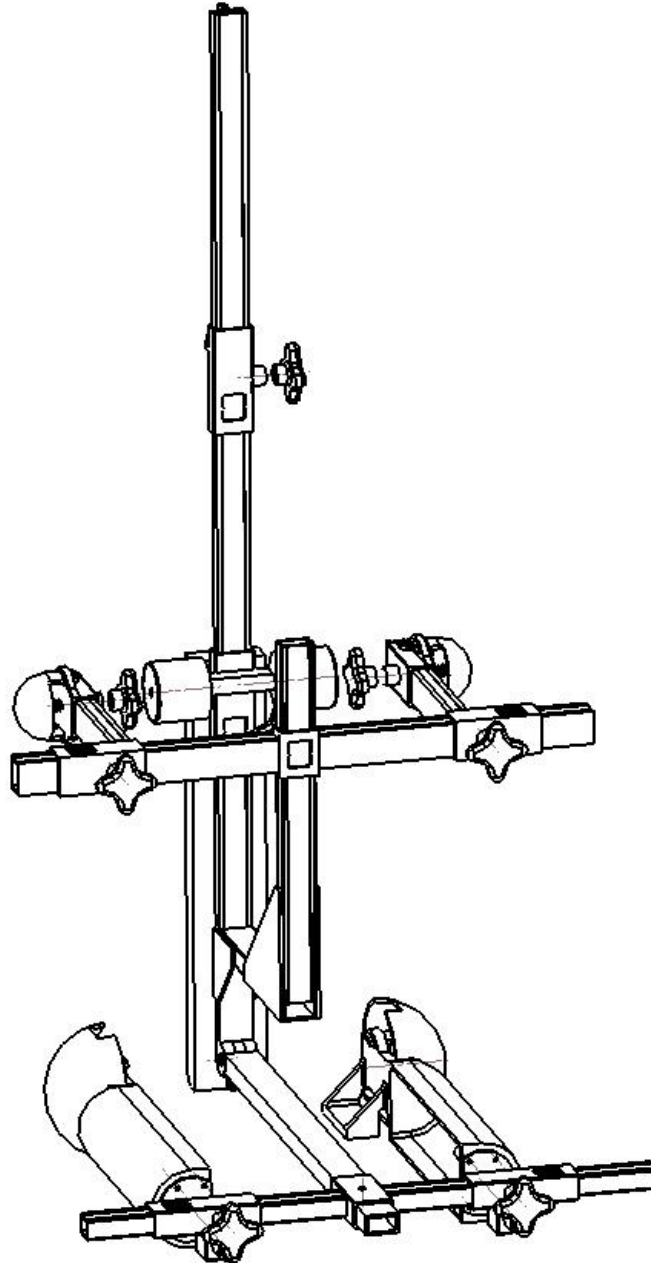

Annex 19

Assessment volumes for i-size support-legs and support-leg feet

Figure 1
Side view of the support leg dimension assessment volume

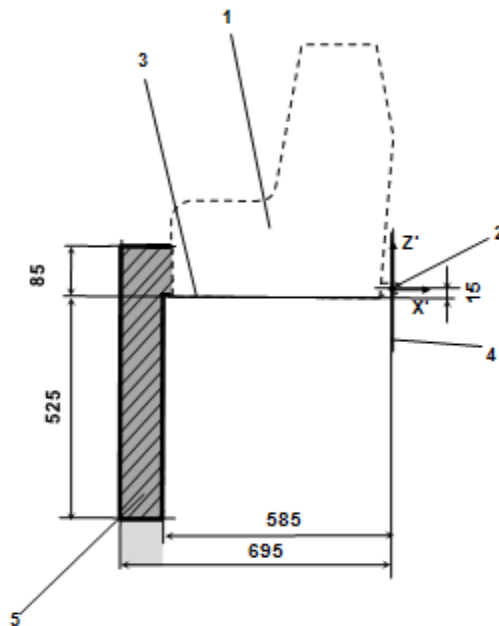

Key:

1. **Enhanced Child Restraint System** Fixture (CRF).
2. ISOFIX low anchorages bar.
3. Plane formed by the bottom surface of the CRF, which is parallel to and 15 mm below the X'-Y' plane of the coordinate system.
4. Z'-Y' plane of the coordinate system.
5. Upper part of the support-leg dimension assessment volume, which shows the dimensional limitations in X' and Y' direction, the upper height limit in Z' direction, as well as the lower height limitation in Z' direction for rigid, not in Z' direction adjustable support leg components.

Note: Drawing not to scale.

Figure 2
3D view of the support leg dimension assessment volume

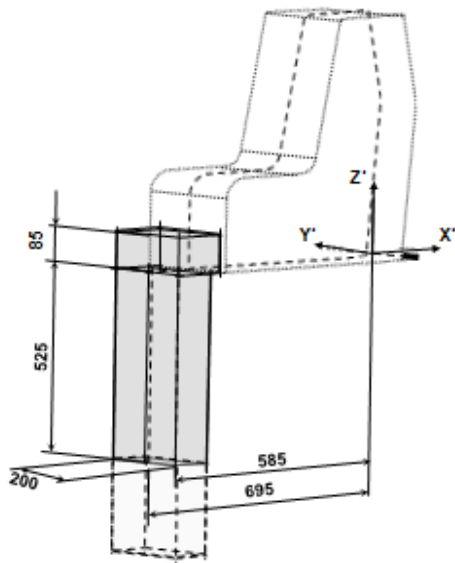

Note: Drawing not to scale.

Figure 3
Side view of the support leg foot assessment volume

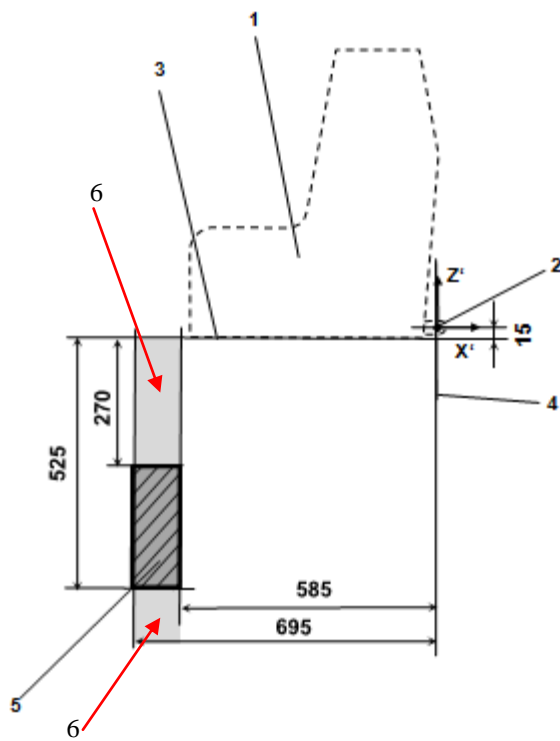

Key:

1. **Enhanced Child Restraint System** Fixture (CRF)
2. ISOFIX low anchorages bar
3. Plane formed by the bottom surface of the CRF, which is parallel to and 15 mm below the X'-Y' plane of the coordinate system
4. Z'-Y' plane of the coordinate system
5. Support-leg foot assessment volume, which shows the required adjustment range of the support-leg foot in Z' directions, as well as the dimensional limitations in X' and Y' direction
6. Additional volumes shows the additional permissible adjustment range in Z' direction for the support-leg foot

Note:

1. Drawing not to scale.

Figure 4

3D view of the support leg foot assessment volume

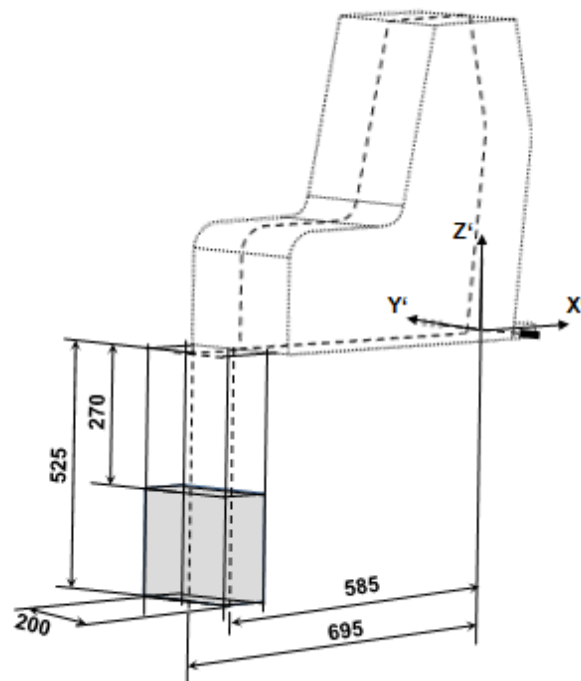

Notes:

1. Drawing not to scale.

Annex 20

Minimum list of documents required for approval

	<i>i-Size ECRS</i>	<i>Specific vehicle ISOFIX ECRS</i>	<i>Paragraph</i>
General documents	Application letter/request	Application letter/request	3.1.
	Technical description of the ECRS	Technical description of the ECRS	3.2.1.
	Installation instruction for retractors	Installation instruction for retractors	3.2.1.
	Declaration on toxicity	Declaration on toxicity	3.2.1.
	Declaration on flammability	Declaration on flammability	3.2.1.
	Instructions and details of packaging	Instructions and details of packaging	3.2.6.
	Material specifications of the parts	Material specifications of the parts	2.46. and 2.2.1.1. of Annex 12
	Assembly instructions for removable parts	Assembly instructions for removable parts	6.2.3.
	Documentation on information for users	Documentation on information for users, including reference to the applicable vehicle(s)	14.
		List of vehicle model(s)	Annex 1
	CoP clearance documents including company organisation chart, Chamber of Commerce registry, production plant declaration, quality system certificate, CoP procedure declaration	CoP clearance documents including company organisation chart, Chamber of Commerce registry, production plant declaration, quality system certificate, CoP procedure declaration and declaration on procedures for sampling per product type	3.1. and Annex 11
Drawings/pictures	Exploded view drawing of ECRS and drawings of all its relevant parts	Exploded view drawing of ECRS and drawings of all its relevant parts	3.2.1. and Annex 1
	Position of approval mark	Position of approval mark	3.2.1.
		Drawings or pictures regarding the combination of the ECRS and the car or the ISOFIX seating position and the relevant car environment ¹	3.2.3.
		Drawings of vehicle and seat structure, adjustment system and attachments ¹	Annex 1
	Photographs of CRS	Photographs of ECRS and/or vehicle and seat structure	Annex 1

	<i>i-Size ECRS</i>	<i>Specific vehicle ISOFIX ECRS</i>	<i>Paragraph</i>
	<p>In case not marked on the sample(s) at the time of submission for approval:</p> <p>Example of marking of manufacturer's name, initials or trade mark, the year of production, orientation, warning labels, i-Size logo, size range, occupant mass and additional markings.</p>	<p>In case not marked on the sample(s) at the time of submission for approval:</p> <p>Example of marking of manufacturer's name, initials or trade mark, the year of production, orientation, warning labels, i-Size logo, size range, occupant mass, specific vehicle ISOFIX marking and additional markings.</p>	4.
<p>¹ In case tested on the test trolley in a vehicle body shell in conformity with paragraph 7.1.3.2. or in a complete vehicle in conformity with paragraph 7.1.3.3. of this Regulation.</p>			

Annex 21

Load application devices

Load application device I

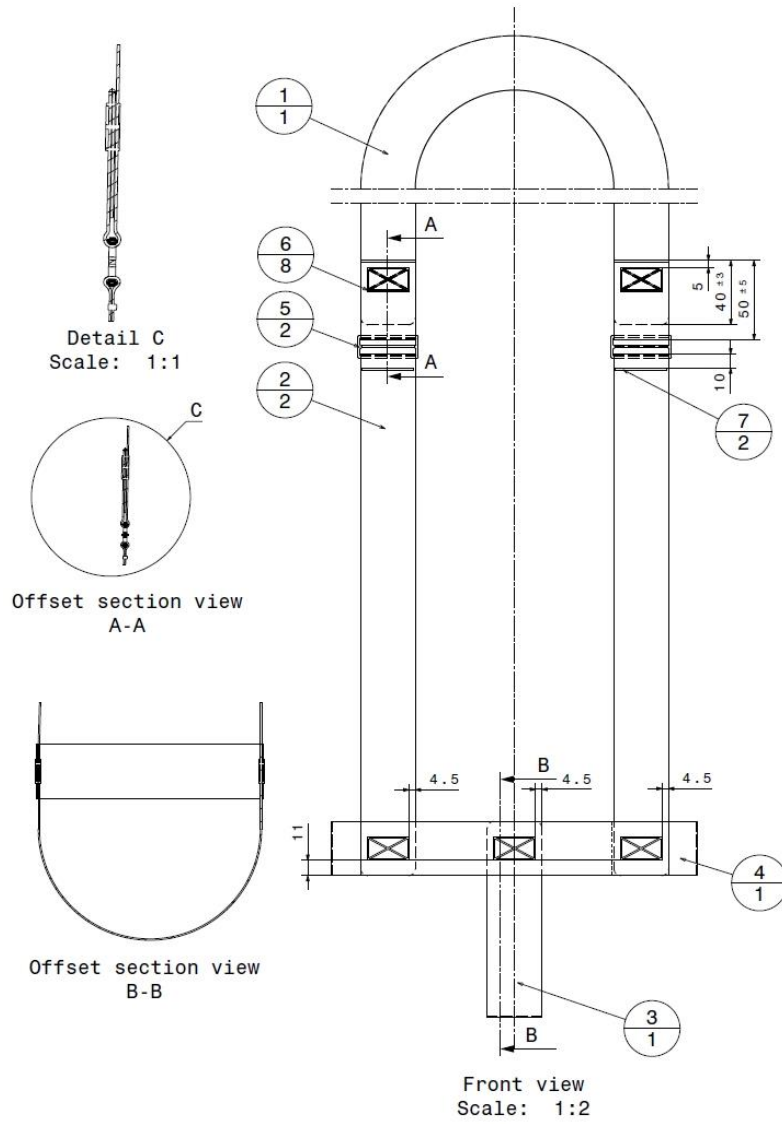

No.	Part Number	Name	Information	Quantity
1	PV000009.1	Head belt – 39 mm	-	1
2	PV000009.2	Shoulder belt lh-rh – 39 mm	-	2
3	PV000009.3	Crotch belt – 39 mm	-	1
4	PV000009.4	Hip belt – 39 mm	-	1
5	102 18 31	Stitch pattern (30 x 17)	Stich: 77, thread: 30, colour: SABA grey	8
6	PV000009.5	Plastic buckle		2
7	PV000009.6	Stitch pattern (2 x 37)	Stich: 77, thread: 30, colour: SABA grey	2

Stretch length	(+/- 5 mm)					
	Dummy Q 0	Q 1	Q 1,5	Q 3	Q 6	Q 10
Head belt	1 000 mm	1 000 mm	1 000 mm	1 200 mm	1 200 mm	1 200 mm
Shoulder belt	750 mm	850 mm	950 mm	1 000 mm	1 100 mm	1 300 mm
Crotch belt	300 mm	350 mm	400 mm	400 mm	450 mm	570 mm
Hip belt	400 mm	500 mm	550 mm	600 mm	700 mm	800 mm
Dimension X	120 mm	130 mm	140 mm	140 mm	150 mm	160 mm

Belt			
Width	Thickness	Expansion	Fastness
39 mm +/- 1 mm	1 mm +/- 0,1 mm	5,5 – 6,5 %	Min. 15 000 N

Stich pattern	Min. required force
12 x 12 mm	3,5 kN
30 x 12 mm	5,3 kN
30 x 17 mm	5,3 kN
30 x 30 mm	7,0 kN

all belt radius = 5 mm

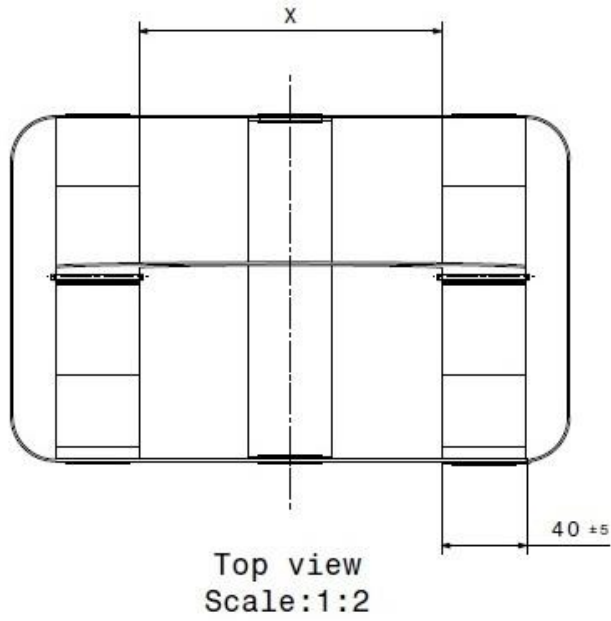

Load application device II

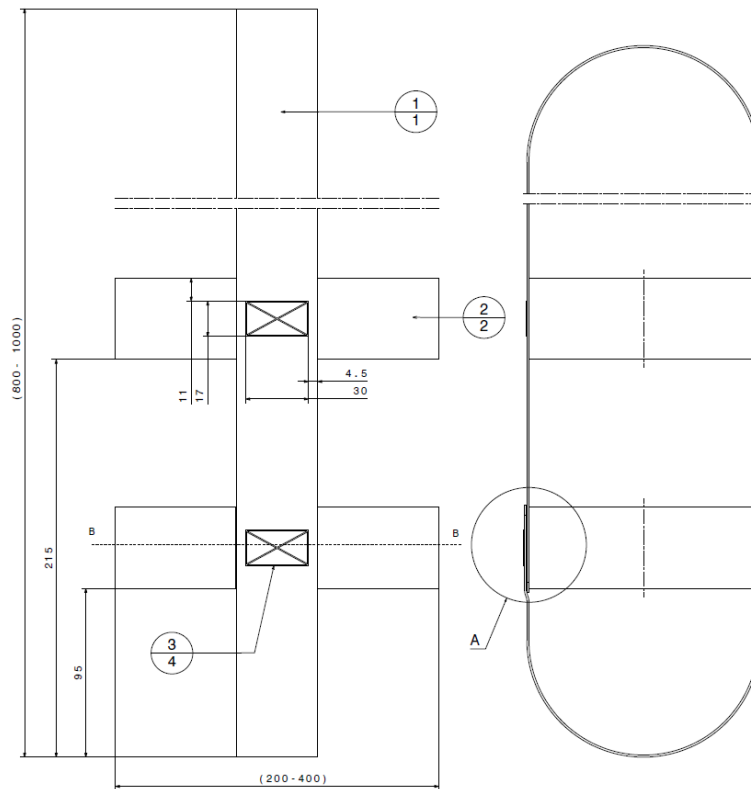

No.	Name	Information	Quantity
1	Main belt – 39 mm	-	1
2	Hip belt (upper/lower)– 39 mm	-	2
3	Stitch pattern (30 x 17)	Stich: 77, thread: 30-	4

Stretch length	(+/- 5 mm)					
	Q 0	Q 1	Q 1,5	Q 3	Q 6	Q 10
Main belt (A)	1 740 mm	1 850 mm	1 900 mm	2 000 mm	2 000 mm	2 100 mm
Hip belt (B)	530 mm	560 mm	600 mm	630 mm	660 mm	700 mm
Lower dimension (C)	125 mm	150 mm	150 mm	170 mm	200 mm	200 mm
Mid dimension (D)	270 mm	300 mm	350 mm	380 mm	380 mm	400 mm

Belt			
Width	Thickness	Expansion	Fastness
39 mm +/- 1 mm	1 mm +/- 0,1 mm	5,5 – 6,5 %	Min. 15 000 N

Stitch pattern	Min. required force
12 x 12 mm	3,5 kN
30 x 12 mm	5,3 kN
30 x 17 mm	5,3 kN
30 x 30 mm	7,0 kN

all belt radius = 5 mm

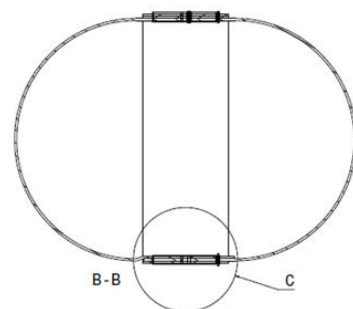
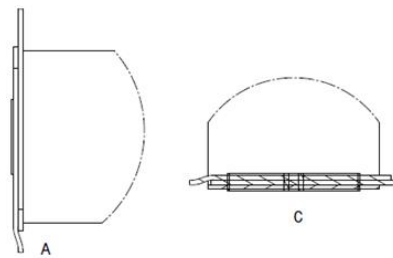

Top view
Scale:1:2



Isometric view
Scale:1:10

Annex 22

Infant carrier module

1. **Definition**

"Infant carrier module" means a module that is part of an Integral Enhanced Child Restraint System restraining a child up to 15-months old and up to 13 kg and which can be used as a stand alone Enhanced Child Restraint System. It is designed to be removed from the vehicle with the child inside and without opening any harness and to carry it outside of the vehicle.
2. **Provisions applied to the infant carrier module**
 - 2.1. **Belt routing shall comply with paragraphs 4.3. and 6.1.9. of Regulation No. 44.**
 - 2.2. **Frontal impact test shall comply with paragraph 7.1.4. of Regulation No. 44.**
 - 2.3. **Rear impact test shall comply with paragraph 7.1.4. of Regulation No. 44.**
 - 2.4. **Overturning test shall comply with paragraph 7.1.3. of Regulation No. 44.**

Annex 23

Standard safety-belt

1. The safety-belt for the dynamic test and for the maximum length requirements shall be made to one of the two configurations shown in Figure 1. These are a three point retracting belt.
2. The three-point retracting belt has the following rigid parts a retractor (R), a pillar loop (P), two anchorage points (A1 and A2) (see Figure 1), and a central part (N, in detail in Figure 3). The retractor shall comply with the requirements of Regulation No. 16 for retraction force. The retractor spool diameter is 33 ± 0.5 mm (example is given in Mutual Resolution No. 1 (M.R.1))
3. The retracting belt shall be fitted to the anchorages on the test bench, described in Annex 6, Appendix 2 as follows:
 - (a) Belt anchorage A1 shall be fitted to trolley anchorages B0 (outboard);
 - (b) Belt anchorage A2 shall be fitted to trolley anchorage A (inboard);
 - (c) Belt pillar loop P shall be fitted to trolley anchorage C;
 - (d) Belt retractor R shall be fitted to trolley anchorage such that the spool centre-line is positioned on Re.

The value of X in Figure 1 below is 200 ± 5 mm. The effective strap length between A1 and the centre-line of the retractor spool Re (when the webbing is fully extracted including the minimum length of 150 mm for testing of Enhanced Child Restraint System shall be ± 5 mm when measured in a straight line without load and on a horizontal surface; this length may be increased for testing of restricted category; for all categories with the Enhanced Child Restraint System installed there shall be a minimum of 150 mm of strap length on the retractor spool.

4. The strap requirements for the belt as follows:
 - (a) Material : polyester spinnblack;
 - (b) Width : 48 ± 2 mm at 10,000 N;
 - (c) Thickness : 1.0 ± 0.2 mm;
 - (d) Elongation : $8 \pm 2\%$ at 10,000 N.

Figure 1
Standard seat belt configurations

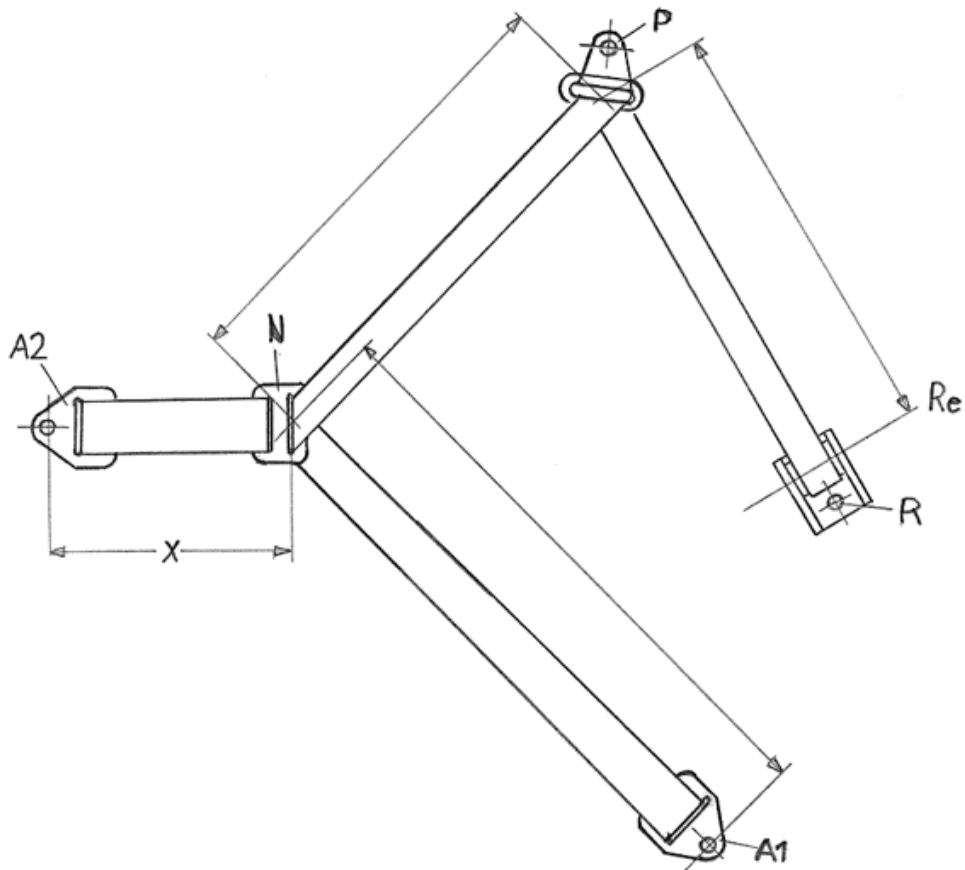

Figure 2
Typical standard anchorage plate

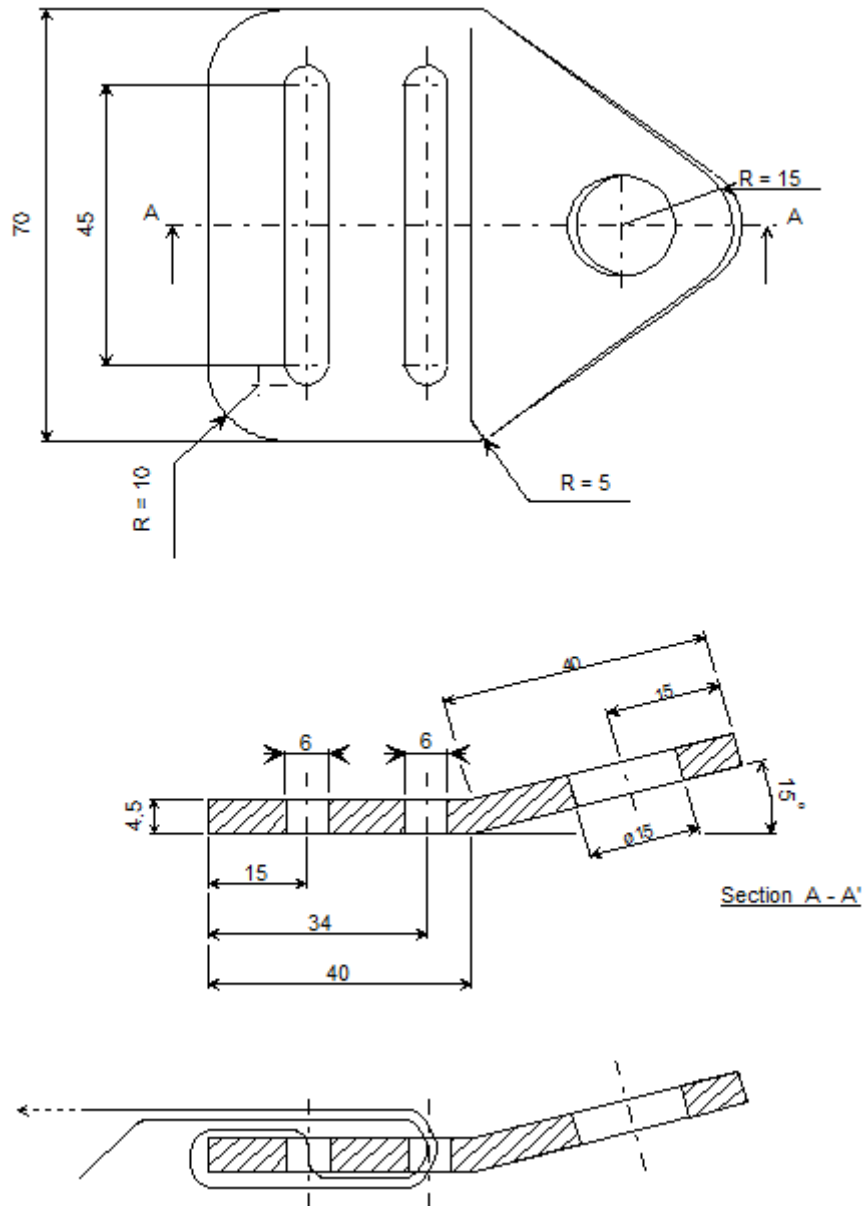

Figure 3
Central part of the standard belt configuration

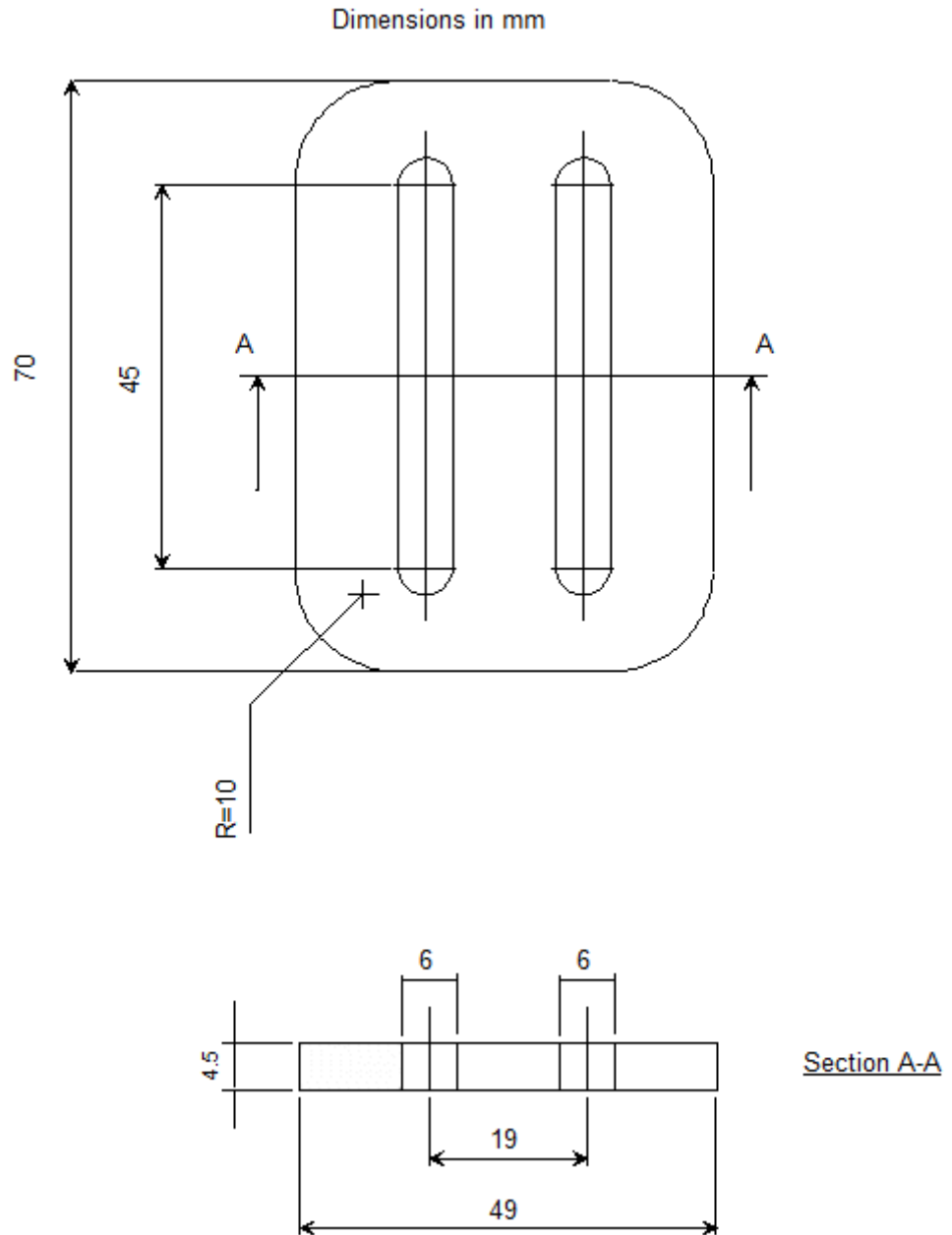

Figure 4
Pillar loop

Finish : Chromium plated

