

## **Proposal for the 05 series of amendments to Regulation No. 10 (Electromagnetic compatibility)**

At its 69th session GRE agreed document GRE/2013/3 and Corr.1 from OICA together with additional amendments, as draft 05 series of amendments to Regulation No. 10 (GRE/69, paragraph 33). This has since become WP.29/2013/73, which was submitted to WP.29 and AC.1 for consideration at their November 2013 sessions as draft 05 series of amendments to Regulation No. 10.

GRE also agreed to resume consideration of an additional proposal from OICA (GRE-69-26 Rev.1) on the basis of a revised document that the expert from OICA volunteered to prepare for the October 2013 session of GRE. This document has since become GRE/2013/41.

In the meantime OICA experts have reviewed WP.29/2013/73 as well as the amendments proposed in GRE/2013/41, and have prepared a revised set of amendments contained in informal document GRE-70-14, which supersedes GRE/2013/41.

Moreover, the OICA experts have consolidated the proposals of documents WP.29/2013/73 and GRE-70-14 in the present document, which constitute the current proposal for the 05 series of amendments to Regulation No. 10 and which supersedes WP.29/2013/73.

*Contents, amend to read:*

"...

6. Specifications in configurations other than REESS charging mode coupled to the power grid
7. Additional specifications in the configuration REESS charging mode coupled to the power grid

..."

*Annexes, insert new Annexes 17 to 22, to read:*

- "17 Method(s) of testing for emission of harmonics generated on AC power lines from an ESA
- 18 Method(s) of testing for emission of voltage changes, voltage fluctuations and flicker on AC power lines from an ESA
- 19 Method(s) of testing for emission of radiofrequency conducted disturbances on AC or DC power lines from an ESA
- 20 Method(s) of testing for emission of radiofrequency conducted disturbances on network and telecommunication access from an ESA
- 21 Method of testing for immunity of an ESA to electrical fast transient/burst disturbances conducted along AC and DC power lines

22 Method of testing for immunity of ESAs to surges conducted along AC and DC power lines"

*Text of the Regulation,*

*Paragraph 1.3., amend to read:*

"1.3. It covers:

- (a) Requirements regarding the immunity ... vehicle statutory data;
- (b) Requirements regarding the control ... retrofitted to the vehicle;
- (c) Additional requirements for vehicles and ESAs providing coupling systems for charging the REESS regarding the control of emissions and immunity from this connection between vehicle and power grid."

*Paragraphs 2.5. to 2.7., amend to read:*

"2.5. *"Broadband emission"* means an emission, which has a bandwidth greater than that of a particular measuring apparatus or receiver (International Special Committee on Radio Interference CISPR 25).

2.6. *"Narrowband emission"* means an emission which has a bandwidth less than that of a particular measuring apparatus or receiver CISPR 25).

2.7. *"Electrical/electronic system"* means (an) electrical and/or electronic device(s) or set(s) of devices together with any associated electrical connections which form part of a vehicle but which are not intended to be type approved separately from the vehicle."

Paragraphs 2.12. to 2.14., amend to read:

- "2.12.        "Immunity related functions" are:
- (a)    Functions related to the direct control of the vehicle:
    - (i)     ...
  - ...
  - (f)    Function related to charging mode when coupled to the power grid:
    - (i)     for vehicle test: by leading to unexpected vehicle motion
    - (ii)    for ESA test: by leading to an incorrect charging condition (e.g. over-current, over-voltage)
- 2.13.        "REESS" means the rechargeable energy storage system that provides electric energy for electric propulsion of the vehicle.
- 2.14.        "Coupling system for charging the REESS" means the electrical circuit installed in the vehicle used for charging the REESS."

Insert a new paragraph 2.15., to read:

- "2.15.        "REESS charging mode coupled to the power grid" means the normal charging operation mode of the vehicle and/or charging system."

Paragraph 3.1.3., amend to read:

- "3.1.3.        The vehicle manufacturer shall draw up ... and those which provide coupling systems for charging the REESS."

Paragraph 3.1.9., amend to read:

- "3.1.9.        Vehicle type approval shall be applied for both REESS and coupling system for charging the REESS as they are considered as electrical/electronic systems."

Paragraph 3.2.1., amend to read:

- "3.2.1.        Applicability of this Regulation to ESA:

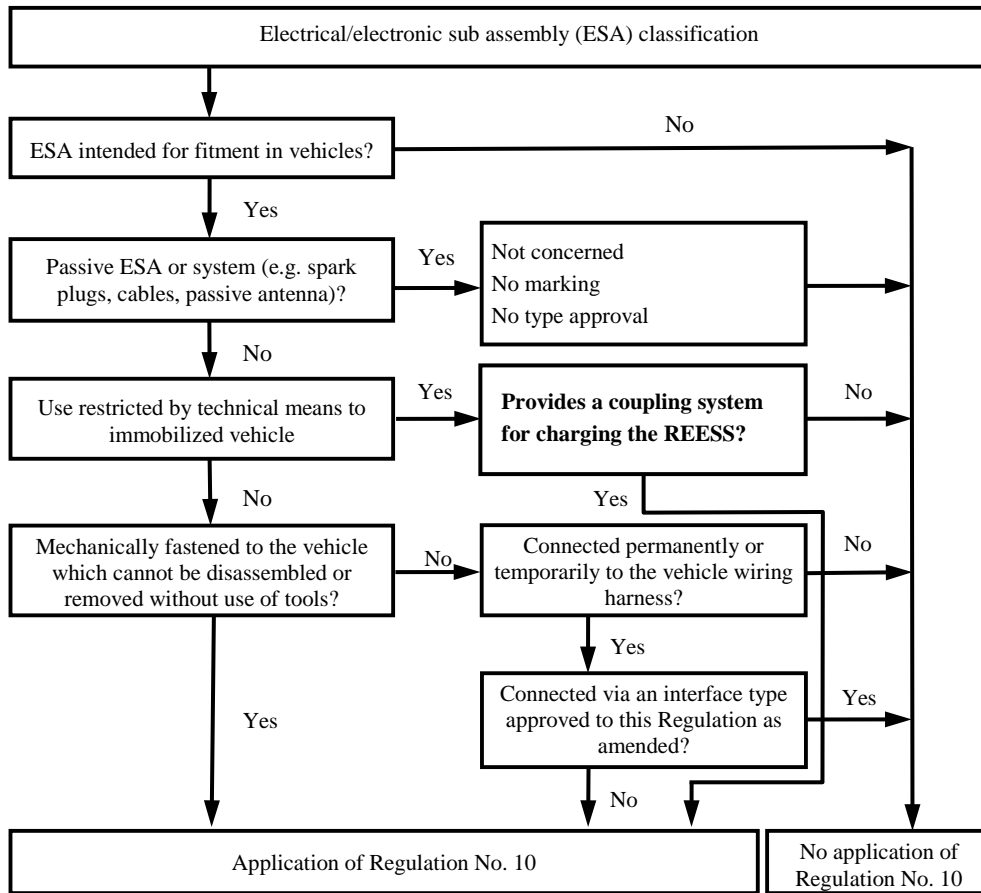

Paragraph 3.2.9., amend to read:

"3.2.9. Components sold as aftermarket equipment and intended for the installation in motor vehicles need no type approval if they are not related to immunity related functions (see paragraph 2.12.). In this case a declaration shall be issued by the manufacturer that the ESA fulfils the requirements of this Regulation and in particular the limits defined in paragraphs 6.5., 6.6., 6.7., 6.8. and 6.9."

Insert a new paragraph 3.2.10., to read:

"3.2.10. The applicant shall specify the approval number(s) according to the Regulation(s), other than this Regulation No. 10, for which approval has also been granted, if applicable."

Paragraph 4.1.1.1., amend to read:

"4.1.1.1. Approval of a vehicle installation

A vehicle installation may be type approved directly by following the provisions laid down in paragraph 6. and, if applicable, in paragraph 7. of this Regulation. If this procedure is chosen by a vehicle manufacturer, no separate testing of electrical/electronic systems or ESAs is required."

Paragraph 4.2.1.1., amend to read:

"4.2.1.1. If the representative vehicle fulfils the requirements of paragraph 6. and, if applicable, paragraph 7. of this Regulation, type approval shall be granted."

Paragraph 4.2.2.1., amend to read:

"4.2.2.1. If the representative ESA system(s) fulfil(s) the requirements of paragraph 6. and, if applicable, paragraph 7. of this Regulation, type approval shall be granted."

Paragraph 5.1., amend to read:

"5.1. An approval number shall be assigned to each vehicle or ESA type approved. The first two digits of this number (at present 05) shall indicate the series of amendments corresponding to the most recent essential technical amendments made to the Regulation at the date of approval. A Contracting Party may not assign the same approval number to another type of vehicle or ESA."

Paragraph 6., amend to read:

"6. Specification in configurations other than REESS charging mode coupled to the power grid"

Paragraphs 6.9. and 6.9.1., renumber as paragraphs 6.7. and 6.7.1., and amend to read:

"6.7. Specifications concerning the emission of transient conducted disturbances generated by ESAs on 12/24 V supply lines.

6.7.1. Method of testing

The emission of ESA representative of its type shall be tested by the method(s) according to ISO 7637-2 as described in Annex 10 for the levels given in Table 1.

Table 1

Maximum allowed pulse amplitude

Polarity of pulse amplitude	Maximum allowed pulse amplitude for	
	Vehicles with 12 V systems	Vehicles with 24 V systems
Positive	+ 75 V	+ 150 V
Negative	- 100 V	- 450 V

Paragraphs 6.7. to 6.7.2.2., renumber as paragraphs 6.8. to 6.8.2.2.

Paragraphs 6.8. and 6.8.1., renumber as paragraphs 6.9. and 6.9.1. and amend to read:

"6.9. Specifications concerning the immunity of ESAs to transient disturbances conducted along 12/24 V supply lines.

6.9.1. Method of testing

The immunity of ESA representative of this type shall be tested by the method(s) according to ISO 7637-2 as described in Annex 10 with the test levels given in Table 2.

Table 2

Immunity of ESA

Test pulse number	Immunity test level	Functional status for systems:	
		Related to immunity related functions	Not related to immunity related functions

1	III	C	D
2a	III	B	D
2b	III	C	D
3a/3b	III	A	D
4	III	B (for ESA which shall be operational during engine start phases) C (for other ESA)	D

*Paragraph 6.10.3.*, amend to read:

"6.10.3. ESAs with no immunity related functions need not be tested for immunity to radiated disturbances and shall be deemed to comply with paragraph 6.8. and with Annex 9 to this Regulation."

*Paragraph 6.10.5.*, amend to read:

"6.10.5. Emission of transient conducted disturbances generated by ESAs on 12/24 V supply lines.

ESAs that are not switched, contain no switches or do not include inductive load need not be tested for transient conducted emission and shall be deemed to comply with paragraph 6.7."

*Paragraphs 7. to 7.1.1.*, amend to read:

"7. Additional specifications in the configuration "REESS charging mode coupled to the power grid"

7.1. General specifications

7.1.1. A vehicle and its electrical/electronic system(s) or ESA(s) shall be so designed, constructed and fitted as to enable the vehicle, in configuration "REESS charging mode coupled to the power grid", to comply with the requirements of this Regulation."

*Paragraph 7.1.2.*, renumber as 7.1.1.1. and amend to read:

"7.1.1.1. A vehicle in configuration "REESS charging mode coupled to the power grid" shall be tested for radiated emissions, immunity to radiated disturbances, conducted emissions and immunity to conducted disturbances."

Insert new paragraph 7.1.1.2., to read:

- "7.1.1.2. ESAs in configuration "REESS charging mode coupled to the power grid" shall be tested for radiated and conducted emissions, for immunity to radiated and conducted disturbances."

Paragraph 7.1.3., renumber as paragraph 7.1.2. and amend to read:

- "7.1.2. Before testing the Technical Service has to prepare a test plan in conjunction with the manufacturer, for the configuration "REESS charging mode coupled to the power grid" configuration which contains at least mode of operation, stimulated function(s), monitored function(s), pass/fail criterion (criteria) and intended emissions."

Insert new paragraphs 7.1.3. and 7.1.4., to read:

- "7.1.3. A vehicle in configuration "REESS charging mode coupled to the power grid" should be tested with the charging cable delivered by the manufacturer. In this case, the cable shall be type approved as part of the vehicle.
- 7.1.4. Artificial networks
- AC Power mains shall be applied to the vehicle / ESA through 50  $\mu$ H/50  $\Omega$  AN(s) as defined in CISPR 16-1-2 clause 4.3.
- DC Power mains shall be applied to the vehicle / ESA through 5  $\mu$ H/50  $\Omega$  AN(s) as defined in CISPR 25.
- High voltage power line shall be applied to the ESA through a 5  $\mu$ H/50  $\Omega$  HV-AN(s) as defined in Appendix 8."

Paragraph 7.3.2.1., amend to read:

- "7.3.2.1. If measurements are made using the method described in Annex 11, the limits for input current  $\leq 16$  A per phase are those defined in IEC 61000-3-2 and given in Table 3.

Table 3  
Maximum allowed harmonics (input current  $\leq 16$  A per phase)

Harmonic number <i>n</i>	Maximum authorized harmonic current A
Odd harmonics	
3	2.3
5	1.14
7	0.77
9	0.40
11	0.33
13	0.21
$15 \leq n \leq 39$	$0.15 \times 15/n$
Even harmonics	
2	1.08
4	0.43
6	0.30
$8 \leq n \leq 40$	$0.23 \times 8/n$

Paragraph 7.3.2.2., amend to read:

"7.3.2.2. If measurements are made using the method described in Annex 11, the limits for input current  $> 16$  A and  $\leq 75$  A per phase are those defined in IEC 61000-3-12, and given in given in Table 4, Table 5 and Table 6."

Paragraph 7.4.2.1., amend to read:

"7.4.2.1. If measurements are made using the method described in Annex 12, the limits for rated current  $\leq 16$  A per phase and not subjected to conditional connection are those defined in IEC 61000-3-3, clause 5."

Table 7, shall be deleted.

Paragraph 7.4.2.2., amend to read:

"7.4.2.2. If measurements are made using the method described in Annex 12, the limits for rated current  $> 16$  A and  $\leq 75$  A per phase and subjected to conditional connection are those defined in IEC 61000-3-11, clause 5."

Table 8, shall be deleted.

Paragraphs 7.5.2.1. and 7.5.2.2., amend to read:

"7.5.2.1. If measurements are made using the method described in Annex 13, the limits on AC power lines are those defined in IEC 61000-6-3 and given in Table 7.

Table 7

**Maximum allowed radiofrequency conducted disturbances on AC power lines**

<i>Frequency (MHz)</i>	<i>Limits and detector</i>
0.15 to 0.5	66 to 56 dB $\mu$ V (quasi-peak) 56 to 46 dB $\mu$ V (average) (linearly decreasing with logarithm of frequency)
0.5 to 5	56 dB $\mu$ V (quasi-peak) 46 dB $\mu$ V (average)
5 to 30	60 dB $\mu$ V (quasi-peak) 50 dB $\mu$ V (average)

7.5.2.2. If measurements are made using the method described in Annex 13, the limits on DC power lines are those defined in IEC 61000-6-3 and given in Table 8.

Table 8

**Maximum allowed radiofrequency conducted disturbances on DC power lines**

<i>Frequency (MHz)</i>	<i>Limits and detector</i>
0.15 to 0.5	79 dB $\mu$ V (quasi-peak) 66 dB $\mu$ V (average)
0.5 to 30	73 dB $\mu$ V (quasi-peak) 60 dB $\mu$ V (average)

Paragraph 7.6.2.1., amend to read:

"7.6.2.1. If measurements are made using the method described in Annex 14, the limits on network and telecommunication access (telecommunication access as defined in clause 3.6. of CISPR22) are those defined in IEC 61000-6-3 and given in Table 9.



Table 9

**Maximum allowed radiofrequency conducted disturbances on network and telecommunication access**

<i>Frequency (MHz)</i>	<i>Voltage limits (detector)</i>	<i>Current limits (detector)</i>
0.15 to 0.5	84 to 74 dB $\mu$ V (quasi-peak) 74 to 64 dB $\mu$ V (average) (linearly decreasing with logarithm of frequency)	40 to 30 dB $\mu$ A (quasi-peak) 30 to 20 dB $\mu$ A (average) (linearly decreasing with logarithm of frequency)
0.5 to 30	74 dB $\mu$ V (quasi-peak) 64 dB $\mu$ V (average)	30 dB $\mu$ A (quasi-peak) 20 dB $\mu$ A (average)

*Paragraph 7.9.2.1.*, amend to read:

"7.9.2.1. If tests are made using the methods described in Annex 16, the immunity test levels shall be:

- (a) For AC power lines:  $\pm 2$  kV test voltage in open circuit between line and earth and  $\pm 1$  kV between lines (pulse 1.2  $\mu$ s / 50  $\mu$ s), with a rise time (Tr) of 1.2  $\mu$ s, and a hold time (Th) of 50  $\mu$ s. Each surge shall be applied five times with a maximum delay of 1 minute between each pulse. This has to be applied for the following phases: 0, 90, 180 and 270°,
- (b) For DC power lines:  $\pm 0.5$  kV test voltage in open circuit between line and earth and  $\pm 0.5$  kV between lines (pulse 1.2  $\mu$ s / 50  $\mu$ s) with a rise time (Tr) of 1.2  $\mu$ s, and a hold time (Th) of 50  $\mu$ s. Each surge shall be applied five times with a maximum delay of 1 minute."

*Insert new paragraphs 7.10. to 7.19.*, to read:

"7.10. Specifications concerning broadband electromagnetic interference caused by ESAs

7.10.1. Method of measurement

The electromagnetic radiation generated by the ESA representative of its type shall be measured by the method described in Annex 7.

7.10.2. ESA broadband type approval limits

7.10.2.1. If measurements are made using the method described in Annex 7, the limits shall be 62 to 52 dB  $\mu$ V/m in the 30 to 75 MHz frequency band, this limit decreasing logarithmically with frequencies above 30 MHz, and 52 to 63 dB  $\mu$ V/m in the 75 to 400 MHz band, this limit increasing logarithmically with frequencies above 75 MHz as shown in Appendix 6. In the 400 to 1,000 MHz frequency band the limit remains constant at 63 dB  $\mu$ V/m.

7.10.2.2. On the ESA representative of its type, the measured values, expressed in dB  $\mu$ V/m, shall be below the type approval limits.

7.11. Specifications concerning emission of harmonics on AC power lines from ESAs

7.11.1. Method of measurement

The harmonics emission on AC power lines generated by the ESA representative of its type shall be measured using the method described in Annex 17. The method of measurement shall be defined by the manufacturer in accordance with the Technical Service.

7.11.2. ESA type approval limit

7.11.2.1. If measurements are made using the method described in Annex 17, the limits for input current  $\leq 16$  A per phase are those defined in IEC 61000-3-2 and given in Table 10.

Table 10

**Maximum allowed harmonics (input current  $\leq 16$  A per phase)**

Harmonic number <i>n</i>	Maximum authorized harmonic current A
<i>Odd harmonics</i>	
3	2.3
5	1.14
7	0.77
9	0.40
11	0.33
13	0.21
$15 \leq n \leq 39$	$0.15 \times 15/n$
<i>Even harmonics</i>	
2	1.08
4	0.43
6	0.30
$8 \leq n \leq 40$	$0.23 \times 8/n$

7.11.2.2. If measurements are made using the method described in Annex 17, the limits for input current  $> 16$  A and  $\leq 75$  A per phase are those defined in IEC 61000-3-12 and given in Table 11, Table 12 and Table 13.

Table 11

**Maximum allowed harmonics (input current  $> 16$  A and  $\leq 75$  A per phase) for equipment other than balanced three-phase equipment.**

Minimum $R_{sce}$	Acceptable individual harmonic current $I_n/I_1$ %						Maximum current harmonic ratio %	
	$I_3$	$I_5$	$I_7$	$I_9$	$I_{11}$	$I_{13}$	THD	PWHD
33	21.6	10.7	7.2	3.8	3.1	2	23	23
66	24	13	8	5	4	3	26	26
120	27	15	10	6	5	4	30	30
250	35	20	13	9	8	6	40	40
$\geq 350$	41	24	15	12	10	8	47	47

Relative values of even harmonics lower or equal to 12 shall be lower than  $16/n$  %. Even harmonics greater than 12 are taken into account in the THD and PWHD in the same way than odd harmonics.  
Linear interpolation between successive values of  $R_{sce}$  is authorized.

Table 12

**Maximum allowed harmonics (input current > 16 A and ≤ 75 A per phase) for balanced three-phase equipment.**

Minimum $R_{sce}$	Acceptable individual harmonic current $I_n/I_1$ %				Maximum current harmonic ratio %	
	$I_5$	$I_7$	$I_{11}$	$I_{13}$	THD	PWHD
33	10.7	7.2	3.1	2	13	22
66	14	9	5	3	16	25
120	19	12	7	4	22	28
250	31	20	12	7	37	38
≥ 350	40	25	15	10	48	46

Relative values of even harmonics lower or equal to 12 shall be lower than  $16/n$  %. Even harmonics greater than 12 are taken into account in the THD and PWHD in the same way as odd harmonics.  
Linear interpolation between successive values of  $R_{sce}$  is authorized.

Table 13

**Maximum allowed harmonics (input current > 16 A and ≤ 75 A per phase) for balanced three-phase equipment under specific conditions**

Minimum $R_{sce}$	Acceptable individual harmonic current $I_n/I_1$ %				Maximum current harmonic ratio %	
	$I_5$	$I_7$	$I_{11}$	$I_{13}$	THD	PWHD
33	10.7	7.2	3.1	2	13	22
≥ 120	40	25	15	10	48	46

Relative values of even harmonics lower or equal to 12 shall be lower than  $16/n$  %. Even harmonics greater than 12 are taken into account in the THD and PWHD in the same way as odd harmonics.

- 7.12. Specifications concerning emission of voltage changes, voltage fluctuations and flicker on AC power lines from ESAs
- 7.12.1. Method of measurement
- The emission of voltage changes, voltage fluctuations and flicker on AC power lines generated by the ESA representative of its type shall be measured using the method described in Annex 18. The method of measurement shall be defined by the ESA manufacturer in accordance with the Technical Service.
- 7.12.2. ESA type approval limit
- 7.12.2.1. If measurements are made using the method described in Annex 18, the limits for rated current ≤ 16 A per phase and not subjected to conditional connection are those defined in IEC 61000-3-3, clause 5.
- 7.12.2.2. If measurements are made using the method described in Annex 18, the limits for rated current > 16 A and ≤ 75 A per phase and subjected to conditional connection are those defined in IEC 61000-3-11, clause 5.
- 7.13. Specifications concerning emission of radiofrequency conducted disturbances on AC or DC power lines from ESA

- 7.13.1. Method of measurement  
The emission of radiofrequency conducted disturbances on AC or DC power lines generated by the ESA representative of its type shall be measured using the method described in Annex 19. The method of measurement shall be defined by the ESA manufacturer in accordance with the Technical Service.
- 7.13.2. ESA type approval limit
  - 7.13.2.1. If measurements are made using the method described in Annex 19, the limits on AC power lines are those defined in IEC 61000-6-3 and given in Table 14.

Table 14  
**Maximum allowed radiofrequency conducted disturbances on AC power lines**

<i>Frequency (MHz)</i>	<i>Limits and detector</i>
0.15 to 0.5	66 to 56 dB $\mu$ V (quasi-peak) 56 to 46 dB $\mu$ V (average) (linearly decreasing with logarithm of frequency)
0.5 to 5	56 dB $\mu$ V (quasi-peak) 46 dB $\mu$ V (average)
5 to 30	60 dB $\mu$ V (quasi-peak) 50 dB $\mu$ V (average)

- 7.13.2.2. If measurements are made using the method described in Annex 19, the limits on DC power lines are those defined in IEC 61000-6-3 and given in Table 15.

Table 15  
**Maximum allowed radiofrequency conducted disturbances on DC power lines**

<i>Frequency (MHz)</i>	<i>Limits and detector</i>
0.15 to 0.5	79 dB $\mu$ V (quasi-peak) 66 dB $\mu$ V (average)
0.5 to 30	73 dB $\mu$ V (quasi-peak) 60 dB $\mu$ V (average)

- 7.14. Specifications concerning emission of radiofrequency conducted disturbances on network and telecommunication access from ESA
  - 7.14.1. Method of measurement  
The emission of radiofrequency conducted disturbances on network and telecommunication access generated by the ESA representative of its type shall be measured using the method described in Annex 20. The method of measurement shall be defined by the ESA manufacturer in accordance with the Technical Service.
  - 7.14.2. ESA type approval limit
    - 7.14.2.1. If measurements are made using the method described in Annex 20, the limits on network and telecommunication access (telecommunication access as defined in Clause 3.6 of CISPR22) are those defined in IEC 61000-6-3 and given in Table 16.

Table 16

**Maximum allowed radiofrequency conducted disturbances on network and telecommunication access**

<i>Frequency (MHz)</i>	<i>Voltage limits (detector)</i>	<i>Current limits (detector)</i>
0.15 to 0.5	84 to 74 dB $\mu$ V (quasi-peak) 74 to 64 dB $\mu$ V (average) (linearly decreasing with logarithm of frequency)	40 to 30 dB $\mu$ A (quasi-peak) 30 to 20 dB $\mu$ A (average) (linearly decreasing with logarithm of frequency)
0.5 to 30	74 dB $\mu$ V (quasi-peak) 64 dB $\mu$ V (average)	30 dB $\mu$ A (quasi-peak) 20 dB $\mu$ A (average)

- 7.15. Specifications concerning the immunity of ESAs to electrical fast transient/burst disturbances conducted along AC and DC power lines.
- 7.15.1. Method of testing
- 7.15.1.1. The immunity to electrical fast transient/burst disturbances conducted along AC and DC power lines of the ESA representative of its type shall be tested by the method described in Annex 21.
- 7.15.2. ESA immunity type approval limits
- 7.15.2.1. If tests are made using the methods described in Annex 21, the immunity test levels, for AC or DC power lines, shall be:  $\pm 2$  kV test voltage in open circuit, with a rise time (Tr) of 5 ns, and a hold time (Th) of 50 ns and a repetition rate of 5 kHz for at least 1 minute.
- 7.15.2.2. The ESA representative of its type shall be considered as complying with immunity requirements if, during the tests performed in accordance with Annex 21, there shall be no degradation of performance of "immunity related functions", according to paragraph 2.2. of Annex 9.
- 7.16. Specifications concerning the immunity of ESAs to surge conducted along AC or DC power lines
- 7.16.1. Method of testing
- 7.16.1.1. The immunity to surge conducted along AC / DC power lines of the ESA representative of its type shall be tested by the method described in Annex 22.
- 7.16.2. ESA immunity type approval limits
- 7.16.2.1. If tests are made using the methods described in Annex 22, the immunity test levels shall be:
- (a) For AC power lines:  $\pm 2$  kV test voltage in open circuit between line and earth and  $\pm 1$  kV between lines (pulse 1.2  $\mu$ s / 50  $\mu$ s), with a rise time (Tr) of 1.2  $\mu$ s, and a hold time (Th) of 50  $\mu$ s. Each surge shall be applied five times with a maximum delay of 1 minute between each pulse. This has to be applied for the following phases: 0, 90, 180 and 270°,
- (b) For DC power lines:  $\pm 0.5$  kV test voltage in open circuit between line and earth and  $\pm 0.5$  kV between lines (pulse 1.2  $\mu$ s / 50  $\mu$ s) with a rise time (Tr) of 1.2  $\mu$ s, and a hold time (Th) of 50  $\mu$ s. Each surge shall be applied five times with a maximum delay of 1 minute.
- 7.16.2.2. The ESA representative of its type shall be considered as complying with immunity requirements if, during the tests performed in accordance with

Annex 22, there shall be no degradation of performance of "immunity related functions", according to paragraph 2.2. of Annex 9.

7.17. Specifications concerning the emission of transient conducted disturbances generated by ESAs on 12 / 24 V supply lines

7.17.1. Method of testing

The emission of ESA representative of its type shall be tested by the method(s) according to ISO 7637-2, as described in Annex 10 for the levels given in Table 17.

Table 17

**Maximum allowed pulse amplitude**

Polarity of pulse amplitude	Maximum allowed pulse amplitude for	
	Vehicles with 12 V systems	Vehicles with 24 V systems
Positive	+ 75 V	+ 150 V
Negative	- 100 V	- 450 V

7.18. Specifications concerning immunity of ESAs to electromagnetic radiation

7.18.1. Method(s) of testing

The immunity to electromagnetic radiation of the ESA representative of its type shall be tested by the method(s) chosen from those described in Annex 9.

7.18.2. ESA immunity type approval limits

7.18.2.1. If tests are made using the methods described in Annex 9, the immunity test levels shall be 60 volts/m rms for the 150 mm stripline testing method, 15 volts/m rms for the 800 mm stripline testing method, 75 volts/m rms for the Transverse Electromagnetic Mode (TEM) cell testing method, 60 mA rms for the Bulk Current Injection (BCI) testing method and 30 volts/m rms for the free field testing method in over 90 per cent of the 20 to 2,000 MHz frequency band, and to a minimum of 50 volts/m rms for the 150 mm stripline testing method, 12.5 volts/m rms for the 800 mm stripline testing method, 62.5 volts/m rms, for the TEM cell testing method, 50 mA rms for the bulk current injection (BCI) testing method and 25 volts/m rms for the free field testing method over the whole 20 to 2,000 MHz frequency band.

7.18.2.2. The ESA representative of its type shall be considered as complying with immunity requirements if, during the tests performed in accordance with Annex 9, there shall be no degradation of performance of "immunity related functions".

7.19. Specifications concerning the immunity of ESAs to transient disturbances conducted along 12 / 24 V supply lines.

7.19.1 Method of testing

The immunity of ESA representative of its type shall be tested by the method(s) according to ISO 7637-2, as described in Annex 10 with the test levels given in Table 18.

Table 18  
Immunity of ESA

Test pulse number	Immunity test level	Functional status for systems:	
		Related to immunity related functions	Not related to immunity related functions
1	III	C	D
2a	III	B	D
2b	III	C	D
3a/3b	III	A	D
4	III	B (for ESA which shall be operational during engine start phases) C (for other ESA)	D

Paragraph 7.10. (former), renumber as paragraph 7.20.

Insert new paragraph 7.20.1, to read:

"7.20.1. When there is no direct connection to a telecommunication network which includes telecommunication service additional to the charging communication service, Annex 14 and Annex 20 shall not apply."

Paragraph 7.10.1. (former), renumber as paragraph 7.20.2.

Insert new paragraphs 7.20.3. to 7.20.5., to read:

"7.20.3. When network and telecommunication access of the ESA uses Power Line Transmission (PLT) on its AC/DC power lines, Annex 20 shall not apply.

7.20.4. Vehicles and / or ESA which are intended to be used in "REESS charging mode coupled to the power grid" in the configuration connected to a DC-charging station with a length of a DC network cable shorter than 30 m do not have to fulfil the requirements of Annex 13, Annex 15, Annex 16, Annex 19, Annex 21 and Annex 22.

In this case, the manufacturer shall provide a statement that the vehicle and/or ESA can be used in "REESS charging mode coupled to the power grid" only with cables shorter than 30 m. This information shall be made publicly available following the type approval.

7.20.5. Vehicles and / or ESA which are intended to be used in "REESS charging mode coupled to the power grid" in the configuration connected to a local / private DC-charging station without additional participants do not have to fulfil requirements of Annexes 13, 15, 16, 19, 21 and 22.

In this case, the manufacturer shall provide a statement that the vehicle and / or ESA can be used in "REESS charging mode coupled to the power grid" only with a local/private DC charging station without additional participants. This information shall be made publicly available following the type approval."

Paragraph 8.2., amend to read:

"8.2. Where the additional or substitution part(s) has (have) not received approval pursuant to this Regulation, and if testing is considered necessary, the whole vehicle shall be deemed to conform if the new or revised part(s) can be shown to conform to the relevant requirements of paragraph 6. and, if

applicable, of paragraph 7. or if, in a comparative test, the new part can be shown not to be likely to adversely affect the conformity of the vehicle type."

*Paragraph 9.1.*, amend to read:

"9.1. Vehicles or components or ESAs approved under this Regulation shall be so manufactured as to conform to the type approved by meeting the requirements set forth in paragraph 6. and, if applicable, in paragraph 7. above."

*Paragraphs 9.3. to 9.3.3.*, amend to read:

"9.3. If the Competent Authority is not satisfied with the checking procedure of the manufacturer, then paragraphs 9.3.1., 9.3.2. and 9.3.3. below shall apply.

9.3.1. When the conformity of a vehicle, component or ESA taken from the series is being verified, production shall be deemed to conform to the requirements of this Regulation in relation to broadband electromagnetic disturbances and narrowband electromagnetic disturbances if the levels measured do not exceed by more than 4 dB (60 per cent) the reference limits prescribed in paragraphs 6.2.2.1., 6.2.2.2., 6.3.2.1., 6.3.2.2. and, if applicable, paragraphs 7.2.2.1. and 7.2.2.2. for vehicles and paragraphs 6.5.2.1., 6.6.2.1., and, if applicable, paragraph 7.10.2.1. for ESAs (as appropriate).

9.3.2. When the conformity of a vehicle, component or ESA taken from the series is being verified, production shall be deemed to conform to the requirements of this Regulation in relation to immunity to electromagnetic radiation if the vehicle ESA does not exhibit any degradation relating to the direct control of the vehicle which could be observed by the driver or other road user when the vehicle is in the state defined in Annex 6, paragraph 4., and is subjected to a field strength, expressed in Volts/m, up to 80 per cent of the reference limits prescribed in paragraph 6.4.2.1., and, if applicable, paragraph 7.7.2.1. for vehicles and paragraph 6.8.2.1. and, if applicable, paragraph 7.18.2.1. for ESAs above.

9.3.3. If the conformity of a component, or Separate Technical Unit (STU) taken from the series is being verified, production shall be deemed to conform to the requirements of this Regulation in relation to immunity to conducted disturbances and emission if the component or STU shows no degradation of performance of "immunity related functions" up to levels given in paragraph 6.9.1. and, if applicable, paragraph 7.19.1., and does not exceed the levels given in paragraph 6.7.1. and, if applicable, paragraph 7.17.1."

*Paragraph 10.1.*, amend to read:

"10.1. The approval granted in respect of a type of vehicle, component or separate technical unit pursuant to this Regulation may be withdrawn if the requirements laid down in paragraph 6. and, if applicable, paragraph 7. above are not complied with or if the selected vehicles fail to pass the tests provided for in paragraph 6. and, if applicable, paragraph 7. above."

*Paragraph 13.1.*, amend to read:

"13.1. General"

*Former paragraphs 13.1. and 13.3. combined to new paragraph 13.1.1.*, to read:

"13.1.1. As from the official date of entry into force of the most recent series of amendments:



- (a) No Contracting Party applying this Regulation shall refuse to grant approval under this Regulation as amended by these most recent series of amendments; and
- (b) Contracting Parties applying this Regulation shall not refuse to grant extensions of approvals to the preceding series of amendments to this Regulation.

*Paragraph 13.8. (former), renumber as paragraph 13.1.2. and amended to read:*

"13.1.2. Notwithstanding paragraphs 13.3.1. to 13.4.2., approvals granted to the preceding series of amendments to the Regulation for vehicle type which are not equipped with a coupling system to charge the REESS, or for component or separate technical unit which doesn't include a coupling part to charge the REESS, shall remain valid and Contracting Parties applying this Regulation shall continue to accept them."

*Insert a new paragraph 13.2., to read:*

"13.2. Transitional provisions applicable to 03 series of amendments."

*Paragraph 13.2. (former), amend to read:*

"13.2.1. As from 11 July 2009 (12 months after the date of entry into force of this Regulation, as amended by the 03 series of amendments), Contracting Parties applying this Regulation shall grant approvals only if the vehicle type, component or separate technical unit to be approved meets the requirements of this Regulation as amended by the 03 series of amendments."

*Paragraphs 13.3. and 13.4. (former), shall be deleted*

*Insert a new paragraph 13.3., to read:*

"13.3. Transitional provisions applicable to the 04 series of amendments."

*Paragraph 13.5., renumber as paragraph 13.3.1. and amend to read:*

"13.3.1. As from 28 October 2014 (36 months after the official date of entry into force of this Regulation, as amended by the 04 series of amendments), Contracting Parties applying this Regulation shall grant approvals only if the vehicle type, component or separate technical unit, to be approved meets the requirements of this Regulation as amended by the 04 series of amendments."

*Paragraphs 13.6. to 13.8. (former), shall be deleted.*

*Insert new paragraphs 13.4. and 13.4.1., to read:*

"13.4. Transitional provisions applicable to the 05 series of amendments.

13.4.1. As from [?? October 2017] ([36] months after the date of entry into force of the 05 series of amendments), Contracting Parties applying this Regulation shall grant type approvals only if the vehicle type, component or separate technical unit, to be approved meets the requirements of this Regulation as amended by the 05 series of amendments."

*Appendix 2, amend to read:*

" ... (See paragraphs 6.2.2.1. and 7.2.2.1. of this Regulation)"

*Appendix 3, amend to read:*

" ... (See paragraphs 6.2.2.2. and 7.2.2.2. of this Regulation)"

*Appendix 6, amend to read:*

" ... (See paragraphs 6.5.2.1. and 7.10.2.1. of this Regulation)"

Insert a new Appendix 8, to read:

## "Appendix 8

### HV artificial network

Figure 1  
HV artificial network

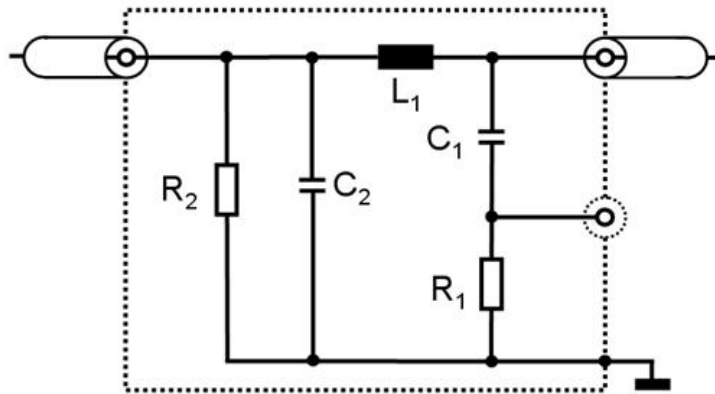

<i>Legend</i>	$C_2: 0.1 \mu F$
$L_1: 5 \mu H$	$R_1: 1 k\Omega$
$C_1: 0.1 \mu F$	$R_2: 1 M\Omega$ (discharging $C_2$ to $< 50 V_{dc}$ within 60 s)

Figure 2  
Impedance of HV artificial network

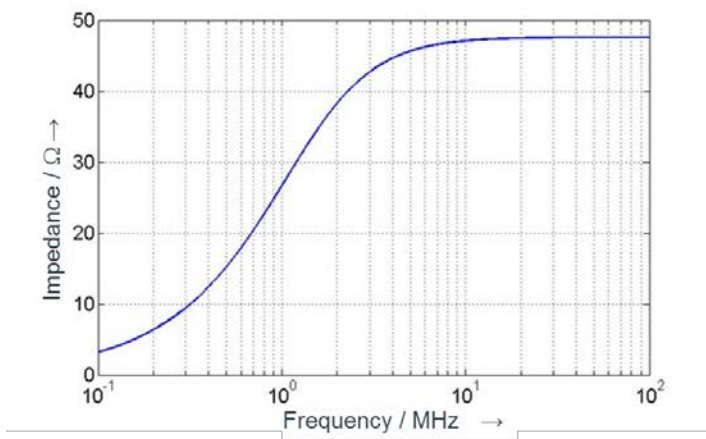
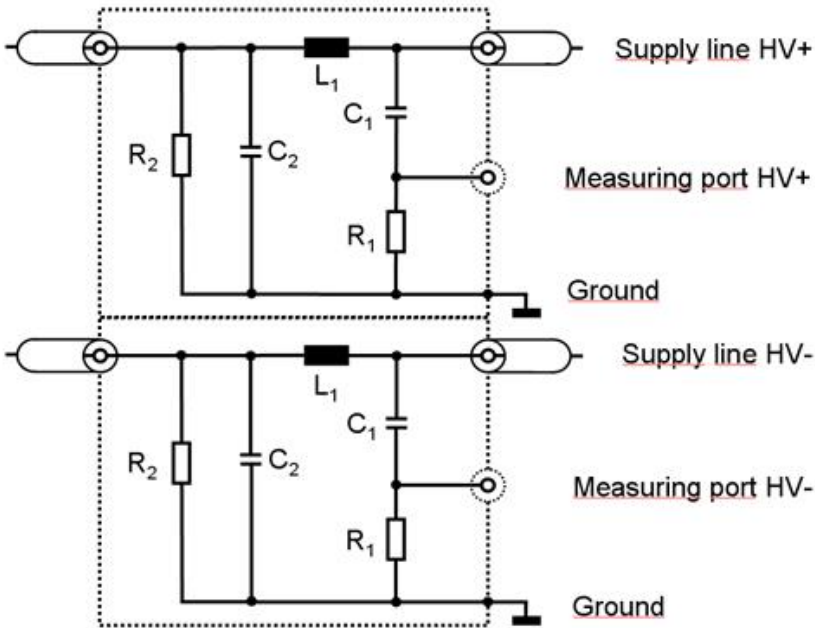

Figure 3  
Combination of HV artificial network



..

Annex 1, amend to read:

## "Annex 1

### Examples of approval marks

Model A

(See paragraph 5.2. of this Regulation)

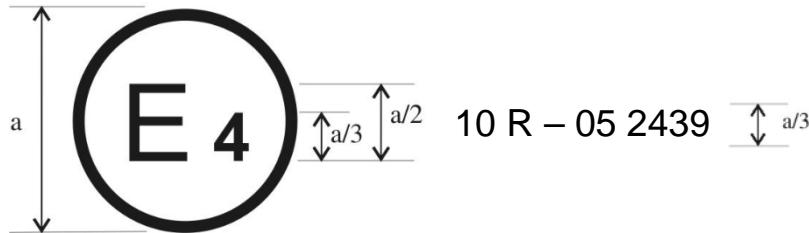

a = 6 mm

The above approval mark affixed to a vehicle or ESA shows that the vehicle type concerned has, with regard to electromagnetic compatibility, been approved in the Netherlands (E 4) pursuant to Regulation No. 10 under approval No. 05 2439. The approval number indicates that the approval was granted according to the requirements of Regulation No. 10 as amended by the 05 series of amendments.

Model B

(See paragraph 5.2. of this Regulation)

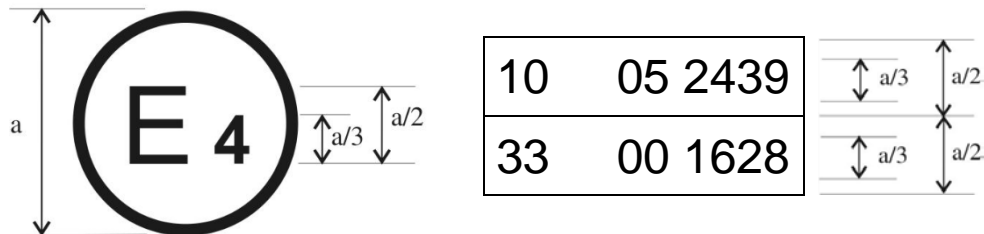

a = 6 mm min

The above approval mark affixed to a vehicle or ESA shows that the vehicle type concerned has, with regard to electromagnetic compatibility, been approved in the Netherlands (E 4) pursuant to Regulations Nos. 10 and 33.<sup>1</sup> The approval numbers indicate that, at the date when the respective approvals were given, Regulation No. 10 included the 05 series of amendments and Regulation No. 33 was still in its original form."

<sup>1</sup> The second number is given merely as an example.

*Annex 2A, insert new items 70. to 72., to read:*

- "70. Minimum Rsce value (see chapter 7.3.)
- 71. Charging cable delivered with the vehicle: yes/no<sup>1</sup>
- 72. If charging cable delivered with the vehicle:
  - Length (m).....
  - Cross sectional area (mm<sup>2</sup>) ....."

*Annex 2B, insert new items 10. to 15., to read:*

"Only applicable for charging systems:

- 10. Charger: on board/external<sup>1</sup>.....
- 11. Charging current: direct current/alternating current (number of phases/frequency)<sup>1</sup>.....
- 12. Maximal nominal current (in each mode if necessary).....
- 13. Nominal charging voltage .....
- 14. Basic ESA interface functions: ex. L1/L2/L3/N/PE/control pilot .....
- 15. Minimum Rsce value (see chapter 7.11.) ....."

Annex 4, amend to read:

## "Annex 4

### **Method of measurement of radiated broadband electromagnetic emissions from vehicles**

1. General
  - 1.1. The test method described in this Annex shall only be applied to vehicles. This method concerns both configurations of the vehicle:
    - (a) Other than "REESS charging mode coupled to the power grid".
    - (b) "REESS charging mode coupled to the power grid"
  - 1.2. Test method

This test is intended to measure the broadband emissions generated by electrical or electronic systems fitted to the vehicle (e.g. ignition system or electric motors).

If not otherwise stated in this Annex the test shall be performed according to CISPR 12.
2. Vehicle state during tests
  - 2.1. Vehicle in configuration other than "REESS charging mode coupled to the power grid".
    - 2.1.1. Engine

The engine shall be in operation according to CISPR 12.
    - 2.1.2. Other vehicle systems

All equipment capable of generating broadband emissions which can be switched on permanently by the driver or passenger should be in operation in maximum load, e.g. wiper motors or fans. The horn and electric window motors are excluded because they are not used continuously.
  - 2.2. Vehicle in configuration "REESS charging mode coupled to the power grid".

The state of charge (SOC) of the traction battery shall be kept between 20 per cent and 80 per cent of the maximum SOC during the whole frequency range measurement (this may lead to split the measurement into different sub-bands with the need to discharge the vehicle's traction battery before starting the next sub-bands). If the current consumption can be adjusted, then the current shall be set to at least 80 per cent of its nominal value.

The test set-up for the connection of the vehicle in configuration "REESS charging mode coupled to the power grid" is shown in Figures 3a to 3h (depending of AC or DC power charging mode, location of charging plug and charging with or without communication) of Appendix 1 to this Annex.
  - 2.3. Charging station / Power mains

The charging station may be placed either in the test location or outside the test location.

*Note 1:* If the communication between the vehicle and the charging station could be simulated, the charging station may be replaced by the supply from power mains.

In both case, duplicated power mains and communication lines socket(s) shall be placed in the test location with the following conditions:

- (a) It shall be placed on the ground plane.
- (b) The length of the harness between the power mains/communication lines socket and the AN(s)/IS(s) shall be kept as short as possible.
- (c) The harness between the power mains/communication lines socket and the AN(s)/IS(s) shall be placed as close as possible to the ground plane.

*Note 2:* The power mains and communication lines socket(s) should be filtered.

If the charging station is placed inside the test location then the harness between charging station and the power mains / communication lines socket shall be placed with the following conditions:

- (a) The harness on charging station side shall hang vertically down to the ground plane.
- (b) The extraneous length shall be placed as close as possible to the ground plane and "Z-folded" if necessary.

*Note 3:* the charging station should be placed outside the beam width of the receiving antenna.

#### 2.4. Artificial networks

The AN(s) shall be mounted directly on the ground plane. The cases of the AN(s) shall be bonded to the ground plane.

The measuring port of each AN shall be terminated with a 50  $\Omega$  load.

The AN shall be placed as defined in Figures 3a to 3h.

#### 2.5. Impedance Stabilization

Communication lines shall be applied to the vehicle through IS(s).

The impedance stabilization (IS) to be connected in the network and communication cables is defined in CISPR 22, paragraph 9.6.2.

The IS(s) shall be mounted directly on the ground plane. The case of the IS(s) shall be bonded to the ground plane.

The measuring port of each IS shall be terminated with a 50  $\Omega$  load.

The IS shall be placed as defined in Figures 3e to 3h.

#### 2.6. Power charging / communication cable

The power charging / communication cable shall be placed in a straight line between the AN(s) / IS(s) and the vehicle charging plug. The projected cable length shall be 0.8 m (+0.2/-0 m).

If the length of the cable is longer than 1 m, the extraneous length shall be "Z-folded" in less than 0.5 m width.

The charging / communication cable at vehicle side shall hang vertically at a distance of 100 mm (+200/-0 mm) from the vehicle body.

The whole cable shall be placed on a non-conductive, low relative permittivity (dielectric-constant) material ( $\epsilon_r \leq 1.4$ ), at 100 mm ( $\pm 25$  mm) above the ground plane.

3. Measuring location
  - 3.1. As an alternative to the requirements of CISPR 12 for vehicles of category L, the test surface may be any location that fulfils the conditions shown in the Figure of the appendix to this annex. In this case the measuring equipment shall lie outside the part shown in Figure 1 of the appendix to this annex.
  - 3.2. Enclosed test facilities may be used if correlation can be shown between the results obtained in the enclosed test facility and those obtained at an outdoor site. Enclosed test facilities do not need to meet the dimensional requirements of the outdoor site other than the distance from the antenna to the vehicle and the height of the antenna.
4. Test requirements
  - 4.1. The limits apply throughout the frequency range 30 to 1,000 MHz for measurements performed in a semi anechoic chamber or an outdoor test site.
  - 4.2. Measurements can be performed with either quasi-peak or peak detectors. The limits given in paragraphs 6.2. and 6.5. of this Regulation are for quasi-peak detectors. If peak detectors are used a correction factor of 20 dB as defined in CISPR 12 shall be applied.
  - 4.3. The measurements shall be performed with a spectrum analyser or a scanning receiver. The parameters to be used are defined in Table 1 and Table 2.

Table 1  
**Spectrum analyser parameters**

Frequency range MHz	Peak detector		Quasi-peak detector		Average detector	
	RBW at -3 dB	Scan time	RBW at -6 dB	Scan time	RBW at -3 dB	Scan time
30 to 1,000	100/120 kHz	100 ms/MHz	120 kHz	20 s/MHz	100/120 kHz	100 ms/MHz

Note:

If a spectrum analyser is used for peak measurements, the video bandwidth shall be at least three times the resolution bandwidth (RBW).

Table 2  
**Scanning receiver parameters**

Frequency range MHz	Peak detector			Quasi-peak detector			Average detector		
	BW at -6 dB	Step size <sup>a</sup>	Dwell time	BW at -6 dB	Step size <sup>a</sup>	Dwell time	BW at -6 dB	Step size <sup>a</sup>	Dwell time
30 to 1,000	120 kHz	50 kHz	5 ms	120 kHz	50 kHz	1 s	120 kHz	50 kHz	5 ms

<sup>a</sup> For purely broadband disturbances, the maximum frequency step size may be increased up to a value not greater than the bandwidth value.

- 4.4. Measurements

The Technical Service shall perform the test at the intervals specified in the CISPR 12 standard throughout the frequency range 30 to 1,000 MHz.



Alternatively, if the manufacturer provides measurement data for the whole frequency band from a test laboratory accredited to the applicable parts of ISO 17025 and recognized by the Type Approval Authority, the Technical Service may divide the frequency range in 14 frequency bands 30–34, 34–45, 45–60, 60–80, 80–100, 100–130, 130–170, 170–225, 225–300, 300–400, 400–525, 525–700, 700–850 and 850–1,000 MHz and perform tests at the 14 frequencies giving the highest emission levels within each band to confirm that the vehicle meets the requirements of this annex.

In the event that the limit is exceeded during the test, investigations shall be made to ensure that this is due to the vehicle and not to background radiation.

4.5. Readings

The maximum of the readings relative to the limit (horizontal and vertical polarization and antenna location on the left and right-hand sides of the vehicle) in each of the 14 frequency bands shall be taken as the characteristic reading at the frequency at which the measurements were made."

Annex 4, Appendix, amend to read:

## "Annex 4 – Appendix

Figure 1

Clear horizontal surface free of electromagnetic reflection delimitation of the surface defined by an ellipse

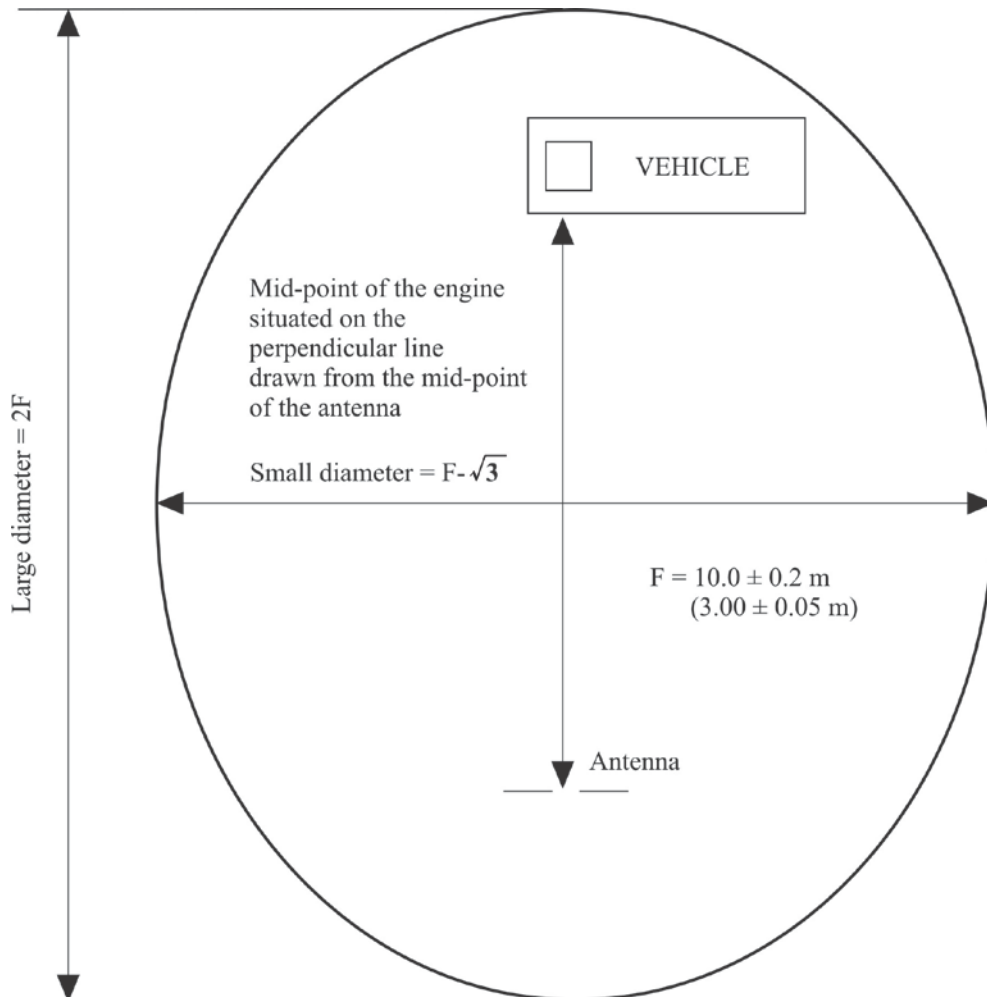

Figure 2  
Position of antenna in relation to the vehicle

Figure 2a  
Dipole antenna in position to measure the vertical radiation components

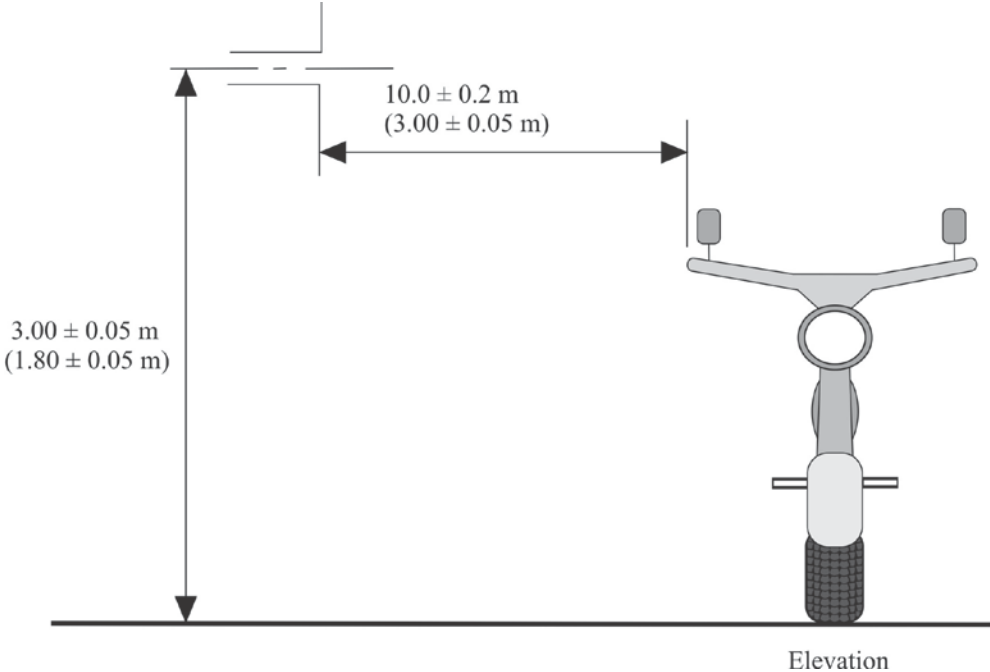

Figure 2b  
Dipole antenna in position to measure the horizontal radiation components

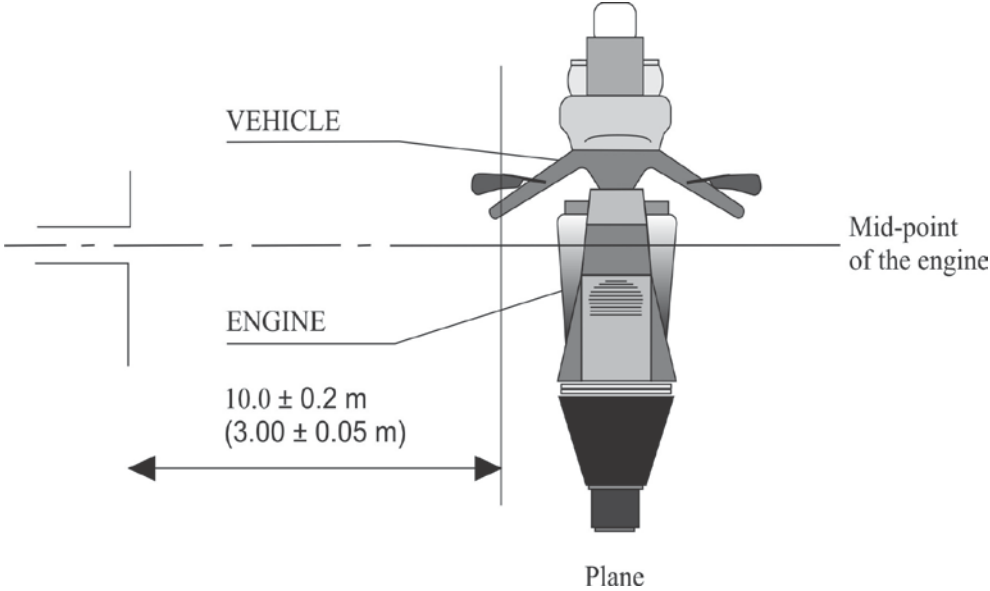

Figure 3  
**Vehicle in configuration "REESS charging mode" coupled to the power grid**

Example of test set-up for vehicle with plug located on vehicle side (AC powered without communication)

Figure 3a

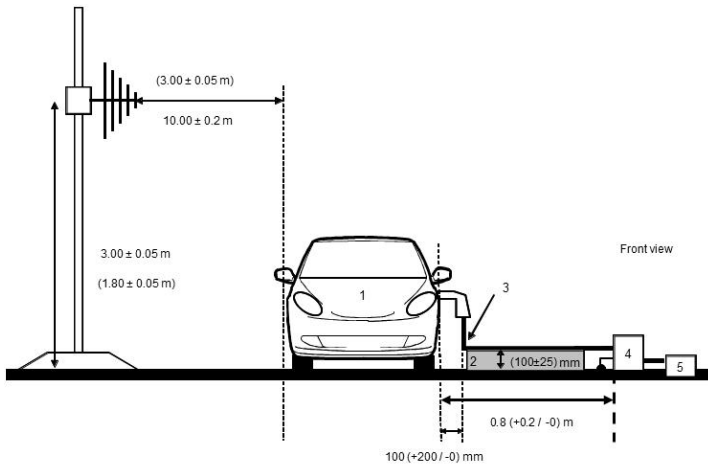
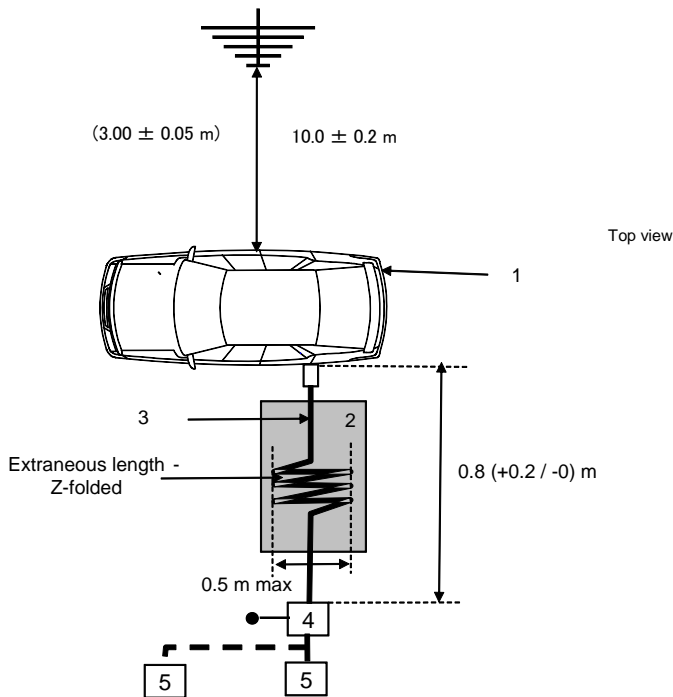

Figure 3b



Legend

- 1 Vehicle under test
- 2 Insulating support
- 3 Charging cable
- 4 Artificial Network(s) grounded
- 5 Power mains socket

Vehicle in configuration "REESS charging mode" coupled to the power grid

Example of test setup for vehicle with plug located front/rear of vehicle (AC powered without communication)

Figure 3c

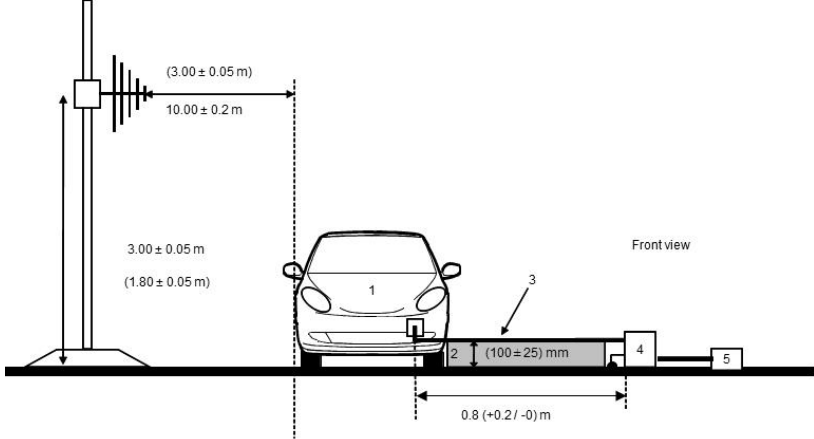
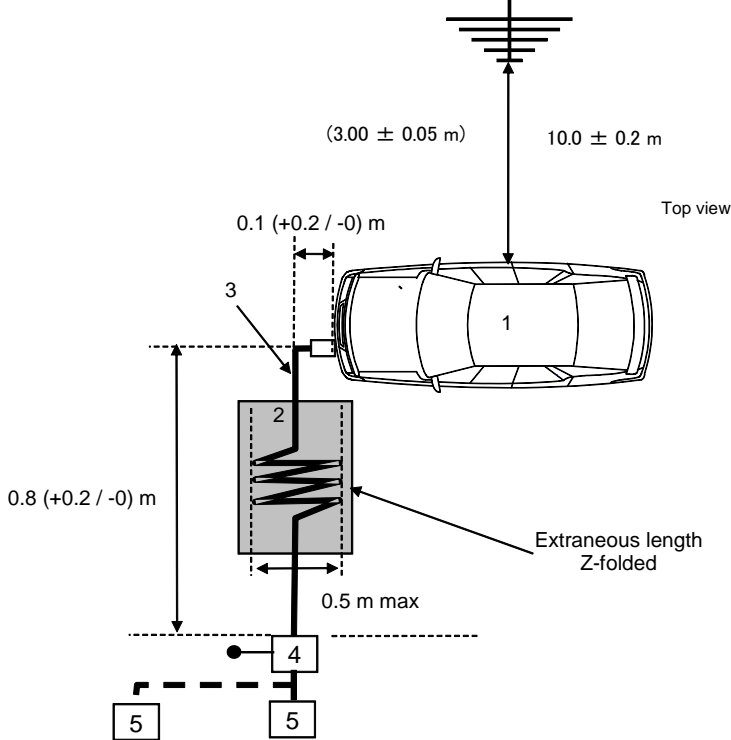

Figure 3d



Legend

- 1 Vehicle under test
- 2 Insulating support
- 3 Charging cable
- 4 Artificial Network(s) grounded
- 5 Power mains socket

Vehicle in configuration "REESS charging mode" coupled to the power grid

Example of test set-up for vehicle with plug located on vehicle side (AC or DC powered with communication)

Figure 3e

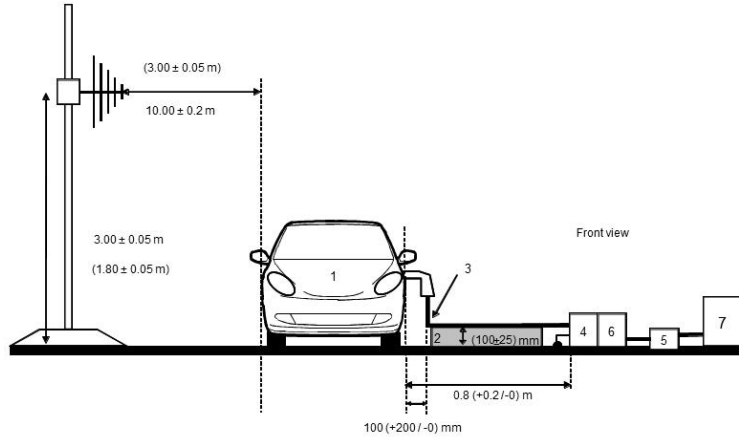
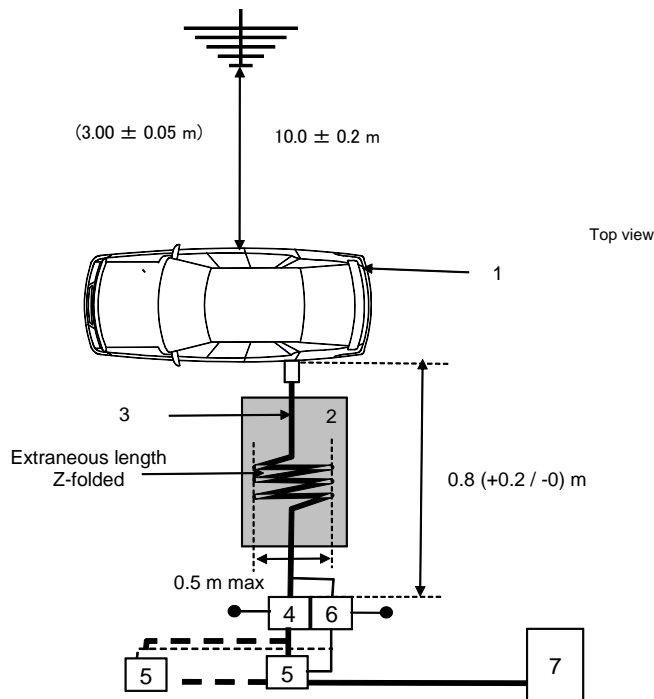

Figure 3f



Legend

- 1 Vehicle under test
- 2 Insulating support
- 3 Charging / communication cable
- 4 AC or DC Artificial Network(s) grounded
- 5 Power mains socket
- 6 Impedance Stabilization(s) grounded
- 7 Charging Station

Vehicle in configuration "REESS charging mode" coupled to the power grid

Example of test setup for vehicle with plug located front/rear of the vehicle (AC or DC powered with communication)

Figure 3g

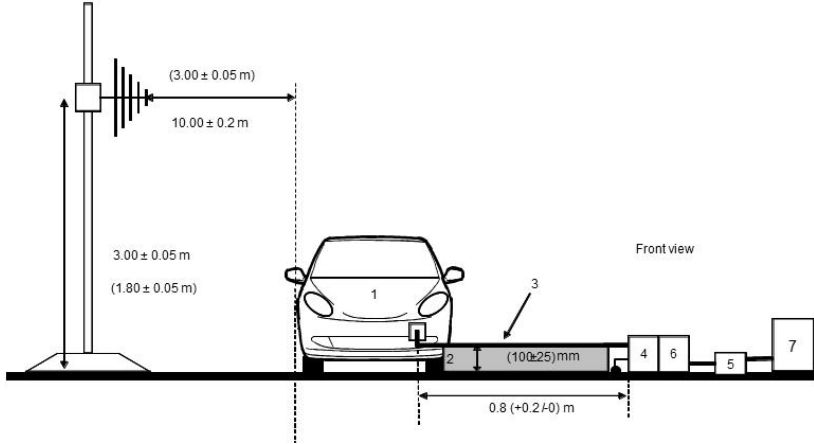
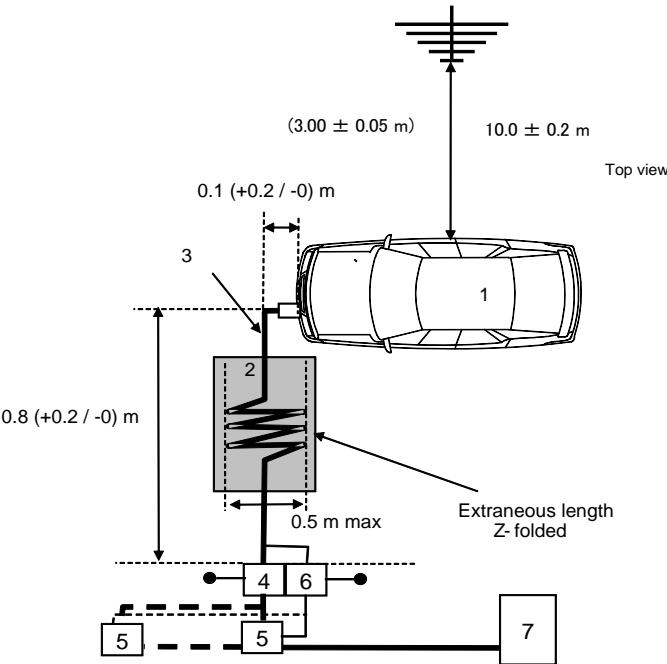

Figure 3h



Legend

- 1 Vehicle under test
- 2 Insulating support
- 3 Charging / communication cable
- 4 AC or DC Artificial Network(s) grounded
- 5 Power mains socket
- 6 Impedance Stabilisation(s) grounded
- 7 Charging Station

Annex 5, paragraphs 1. to 1.2., amend to read:

- "1. General
- 1.1. The test method described in this annex shall only be applied to vehicles. This method concerns only the configuration of the vehicle other than "REESS charging mode coupled to the power grid".
- 1.2. Test method
 

This test is intended to measure the narrowband electromagnetic emissions that may emanate from microprocessor-based systems or other narrowband source.

If not otherwise stated in this annex the test shall be performed according to CISPR 12 or CISPR 25."

Annex 5, insert a new paragraph 3.3., to read:

- "3.3. The measurements shall be performed with a spectrum analyser or a scanning receiver. The parameters to be used are defined in Table 1 and Table 2.

Table 1  
Spectrum analyser parameters

Frequency range MHz	Peak detector		Quasi-peak detector		Average detector	
	RBW at -3 dB	Scan time	RBW at -6 dB	Scan time	RBW at -3 dB	Scan time
30 to 1,000	100/120 kHz	100 ms/MHz	120 kHz	20 s/MHz	100/120 kHz	100 ms/MHz

Note: If a spectrum analyser is used for peak measurements, the video bandwidth shall be at least three times the resolution bandwidth (RBW)

Table 2  
Scanning receiver parameters

Frequency range MHz	Peak detector			Quasi-peak detector			Average detector		
	BW at -6 dB	Step size <sup>a</sup>	Dwell time	BW at -6 dB	Step size <sup>a</sup>	Dwell time	BW at -6 dB	Step size <sup>a</sup>	Dwell time
30 to 1,000	120 kHz	50 kHz	5 ms	120 kHz	50 kHz	1 s	120 kHz	50 kHz	5 ms

<sup>a</sup> For purely broadband disturbances, the maximum frequency step size may be increased up to a value not greater than the bandwidth value."

Annex 5, paragraph 3.3. (former), renumber as paragraph 3.4. and amend to read:

- "3.4. Measurements
 

The Technical Service shall perform the test at the intervals specified in the CISPR 12 standard throughout the frequency range 30 to 1,000 MHz.

Alternatively, if the manufacturer provides measurement data for the whole frequency band from a test laboratory accredited to the applicable parts of ISO 17025 and recognized by the Type Approval Authority, the Technical Service may divide the frequency range in 14 frequency bands 30–34, 34–45, 45–60, 60–80, 80–100, 100–130, 130–170, 170–225, 225–300, 300–400, 400–525, 525–700, 700–850 and 850–1,000 MHz and perform tests at the 14 frequencies giving the highest emission levels within each band to confirm that the vehicle meets the requirements of this Annex.



In the event that the limit is exceeded during the test, investigations shall be made to ensure that this is due to the vehicle and not to background radiation including broadband radiation from any ESA."

Annex 5, paragraph 3.4. (former), renumber as paragraph 3.5.

Annex 6, paragraphs 1. to 1.3., amend to read:

"1. General

1.1. The test method described in this annex shall only be applied to vehicles. This method concerns both configurations of vehicle:

- (a) Other than "REESS charging mode coupled to the power grid".
- (b) "REESS charging mode coupled to the power grid"

1.2. Test method

This test is intended to demonstrate the immunity of the vehicle electronic systems. The vehicle shall be subject to electromagnetic fields as described in this annex. The vehicle shall be monitored during the tests.

If not otherwise stated in this annex the test shall be performed according to ISO 11451-2.

1.3. Alternative test methods

The test may be alternatively performed in an outdoor test site for all vehicles. The test facility shall comply with (national) legal requirements regarding the emission of electromagnetic fields.

If a vehicle is longer than 12 m and/or wider than 2.60 m and/or higher than 4.00 m, BCI (bulk current injection) method according to ISO 11451-4 shall be used in the frequency range 20 to 2,000 MHz with levels defined in paragraph 6.8.2.1. of this Regulation."

Annex 6, paragraph 2.1., amend to read:

"2.1. Vehicle in configuration other than "REESS charging mode coupled to the power grid."

Annex 6, paragraph 2.2., amend to read:

"2.2. Vehicle in configuration "REESS charging mode coupled to the power grid".

Annex 6, paragraph 2.2.1.2., amend to read:

"2.2.1.2. Basic vehicle conditions

The paragraph defines minimum test conditions (as far as applicable) and failures criteria for vehicle immunity tests. Other vehicle systems, which can affect immunity related functions, shall be tested in a way to be agreed between manufacturer and Technical Service.

<i>"REESS charging mode" vehicle test conditions</i>	<i>Failure criteria</i>
The REESS shall be in charging mode. The REESS state of charge (SOC) shall be kept between 20 per cent and 80 per cent of the maximum SOC during the whole frequency range measurement (this may lead to split the measurement in different sub-bands with the need to discharge the vehicle's traction battery before starting the next sub-bands). If the current consumption can be adjusted, then the current shall be set to at least 20 per cent of its nominal value.	Vehicle sets in motion.

Annex 6, insert new paragraphs 2.2.3. to 2.6., to read:

"2.2.3. The test set-up for the connection of the vehicle in configuration "REESS charging mode coupled to the power grid" is shown in Figures 4a to 4h (depending of AC or DC power charging mode, location of charging plug and charging with or without communication) of the appendix to this annex.

2.3. Charging station / Power mains

The charging station may be placed either in the test location or outside the test location.

*Note 1:* If the communication between the vehicle and the charging station could be simulated, the charging station may be replaced by the supply from power mains.

In both case duplicated power mains and communication lines socket(s) shall be placed in the test location with the following conditions:

- (a) It shall be placed on the ground plane.
- (b) The length of the harness between the power mains / communication lines socket and the AN(s) / IS(s) shall be kept as short as possible.
- (c) The harness between the power mains / communication lines socket and the AN(s) / IS(s) shall be placed as close as possible of the ground plane.

*Note 2:* The power mains and communication lines socket(s) should be filtered.

If the charging station is placed inside the test location then harness between charging station and the power mains / communication lines socket shall be placed with the following conditions:

- (a) The harness at charging station side shall hang vertically down to the ground plane.
- (b) The extraneous length shall be placed as close as possible of the ground plane and "Z-folded" if necessary.

*Note 3:* the charging station should be placed outside the beam width of the emitting antenna.

2.4. Artificial networks

The AN(s) shall be mounted directly on the ground plane. The cases of the AN(s) shall be bonded to the ground plane.

The measuring port of each AN shall be terminated with a 50  $\Omega$  load.

The AN shall be placed as defined in Figures 4a to 4h.

2.5. Impedance Stabilization

Communication lines shall be applied to the vehicle through IS(s).

The impedance stabilization (IS) to be connected in the network and communication cables is defined in CISPR 22 paragraph 9.6.2.

The IS(s) shall be mounted directly on the ground plane. The case of the IS(s) shall be bonded to the ground plane.

The measuring port of each IS shall be terminated with a 50  $\Omega$  load.

The IS shall be placed as defined in Figures 4e to 4h.

2.6. Power charging / communication cable

The power charging / communication cable shall be placed in a straight line between the AN(s) / IS(s) and the vehicle charging plug. The projected cable length shall be 0.8 m (+0.2/-0 m).

If the length of the cable is longer than 1 m, the extraneous length shall be "Z-folded" in less than 0.5 m width.

The charging / communication cable at vehicle side shall hang vertically at a distance of 100 mm (+200/-0 mm) from the vehicle body.

The whole cable shall be placed on a non-conductive, low relative permittivity (dielectric-constant) material ( $\epsilon_r \leq 1.4$ ), at 100 mm ( $\pm 25$  mm) above the ground plane."

*Annex 6, paragraph 3.2.*, amend to read:

"3.2. For category M, N, O vehicles according to ISO 11451-2."

*Annex 6, paragraph 4.1. and 4.1.1.*, amend to read:

"4.1. Frequency range, dwell times, polarization

The vehicle shall be exposed to electromagnetic radiation in the 20 to 2,000 MHz frequency ranges in vertical polarization.

The test signal modulation shall be:

- (a) AM (amplitude modulation), with 1 kHz modulation and 80 per cent modulation depth in the 20 to 800 MHz frequency range, and
- (b) PM (pulse modulation), Ton 577  $\mu$ s, period 4,600  $\mu$ s in the 800 to 2,000 MHz frequency range,

if not otherwise agreed between Technical Service and vehicle manufacturer.

Frequency step size and dwell time shall be chosen according to ISO 11451-1.

4.1.1. The Technical Service shall perform the test at the intervals specified in ISO 11451-1 throughout the frequency range 20 to 2,000 MHz.

Alternatively, if the manufacturer provides measurement to data for the whole frequency band from a test laboratory accredited to the applicable parts of ISO 17025 and recognized by the Type Approval Authority, the Technical Service may choose a reduced number of spot frequencies in the range, e.g. 27, 45, 65, 90, 120, 150, 190, 230, 280, 380, 450, 600, 750, 900, 1,300 and 1,800 MHz to confirm that the vehicle meets the requirements of this annex.

If a vehicle fails the test defined in this annex, it shall be verified as having failed under the relevant test conditions and not as a result of the generation of uncontrolled fields."

*Annex 6, paragraph 5.1.1.*, amend to read:

"5.1.1. The substitution method according to ISO 11451-1, shall be used to establish the test field conditions."

Annex 6, Appendix, amend to read:

## "Annex 6 – Appendix

Figure 1

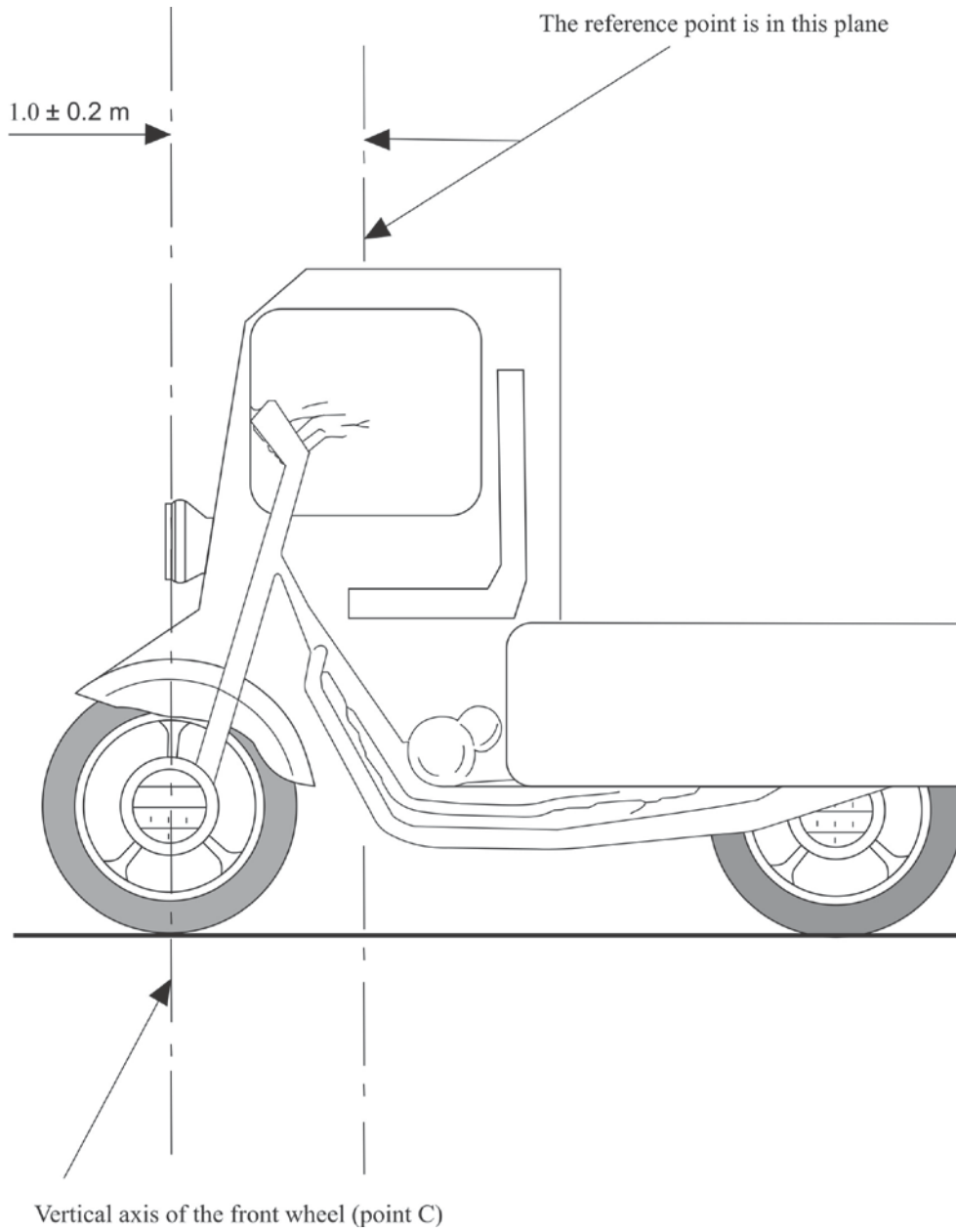

Figure 2

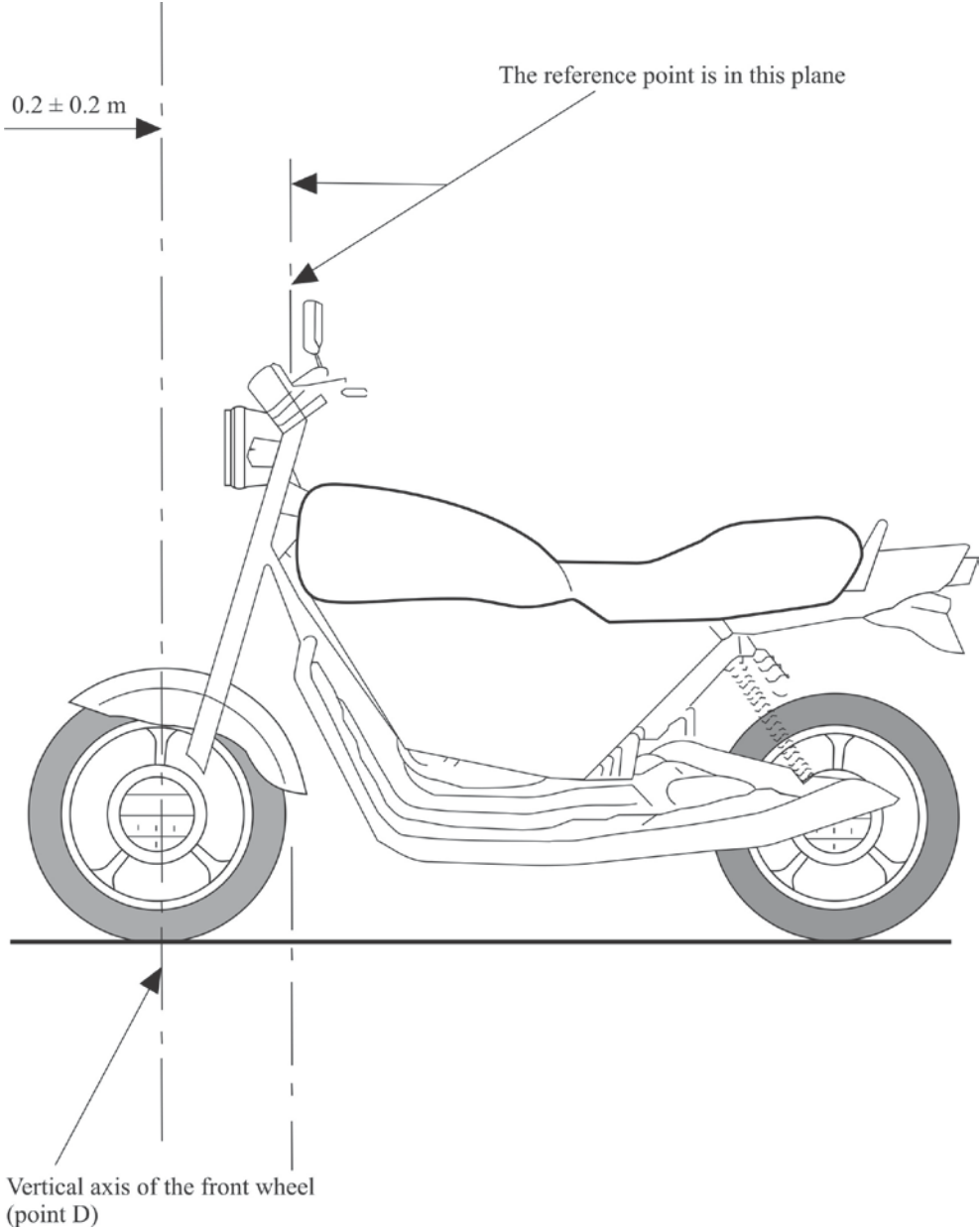

Figure 3

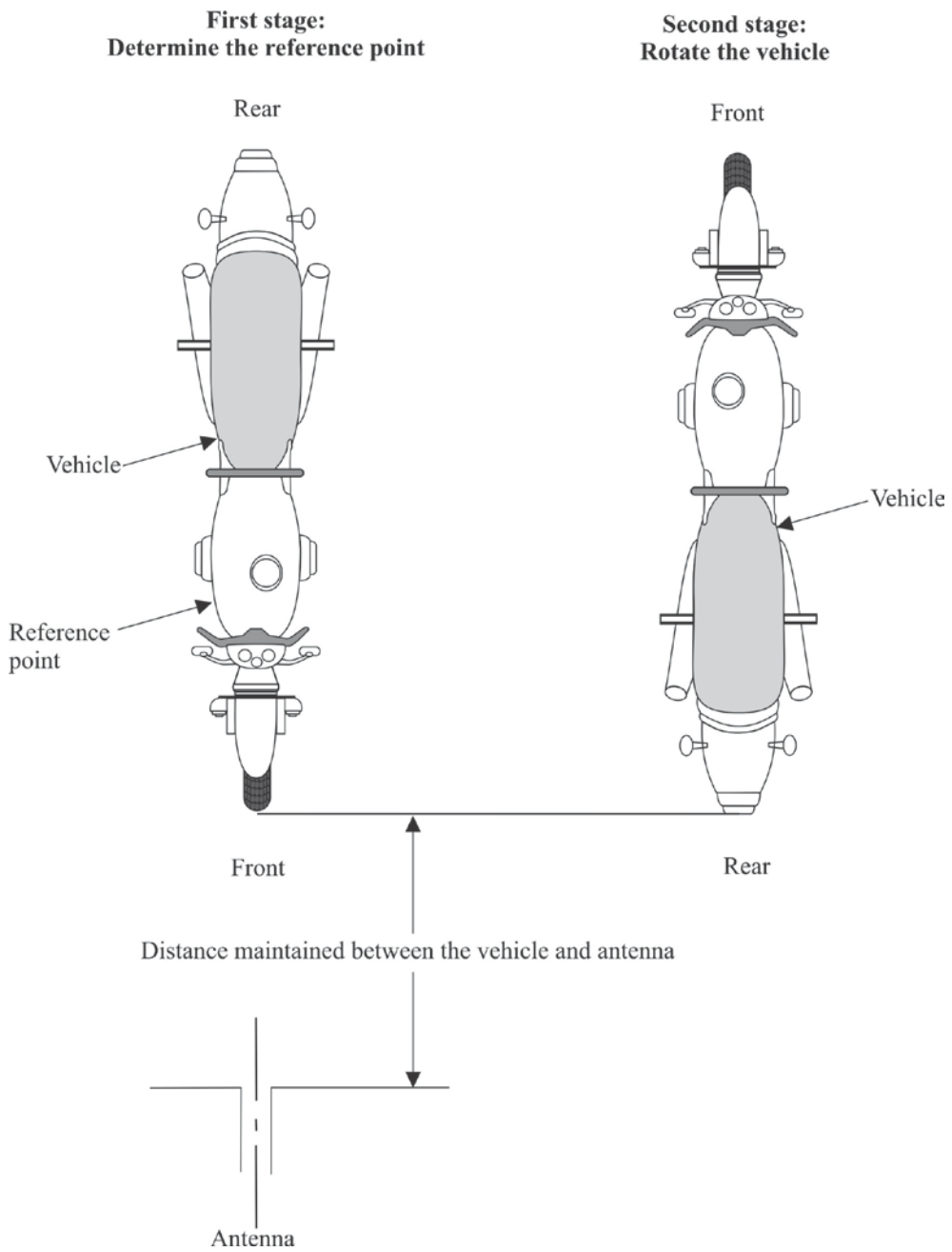

Figure 4  
Vehicle in configuration "REESS charging mode coupled to the power grid"

Example of test set-up for vehicle with plug located on the vehicle side (AC power charging without communication)

Figure 4a

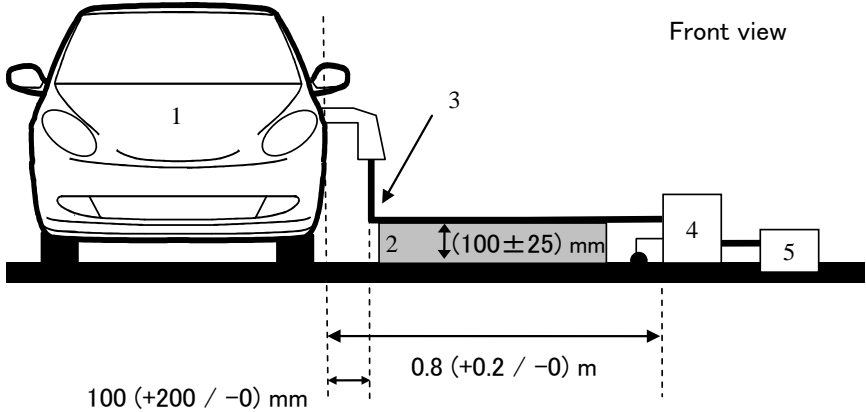
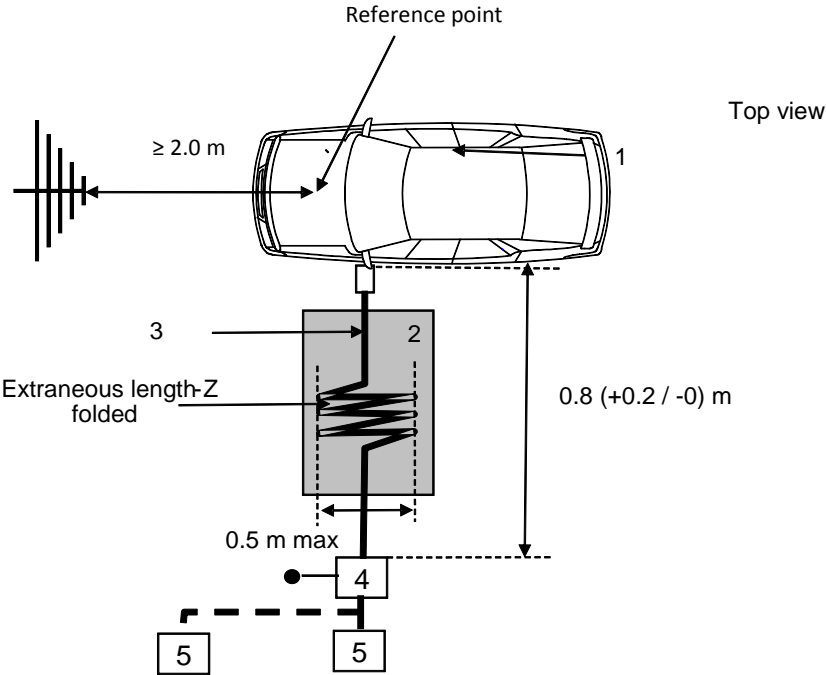

Figure 4b



Legend

- 1 Vehicle under test
- 2 Insulating support
- 3 Charging cable
- 4 Artificial Network(s) grounded
- 5 Power mains socket

Example of test set-up for vehicle with plug located front / rear of vehicle (AC power charging without communication)

Figure 4c

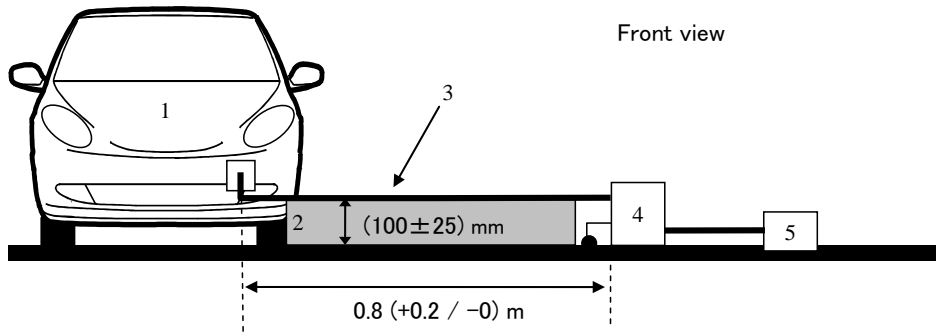
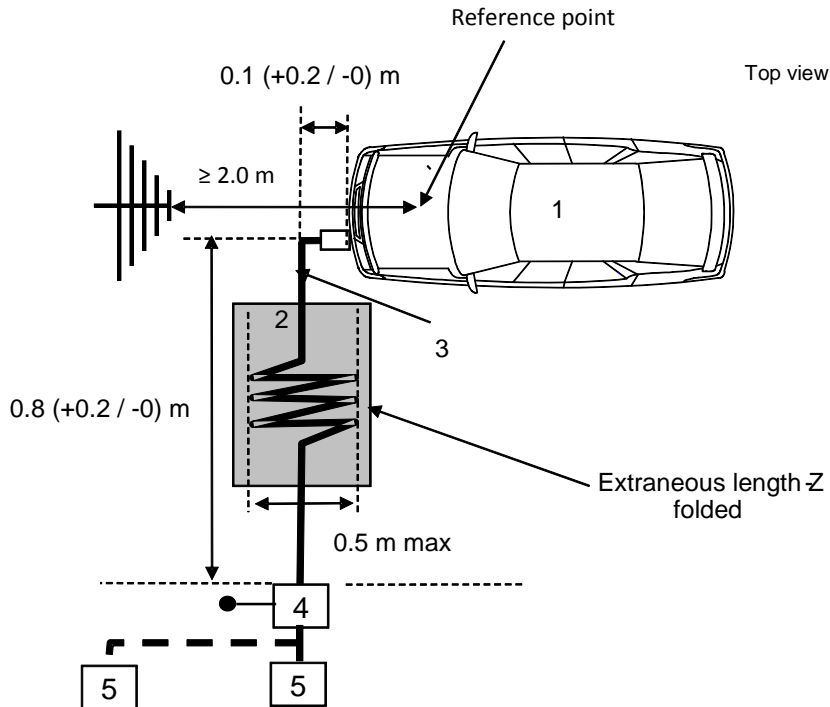

Figure 4d



Legend

- 1 Vehicle under test
- 2 Insulating support
- 3 Charging cable
- 4 Artificial Network(s) grounded
- 5 Power mains socket



Example of test set-up for vehicle with plug located on vehicle side (AC or DC power charging with communication)

Figure 4e

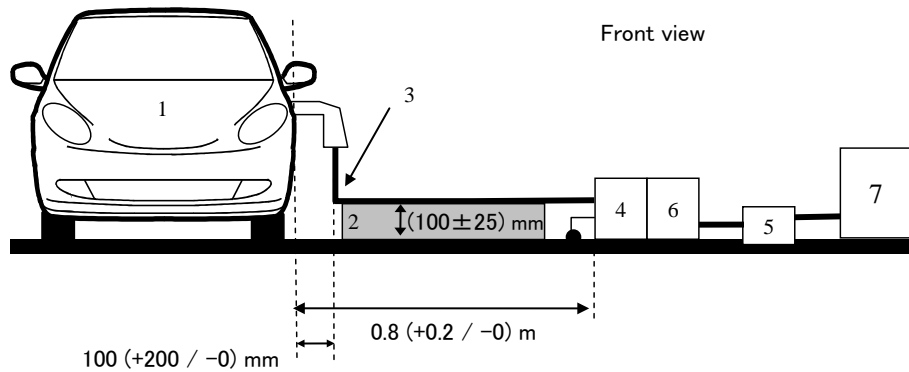
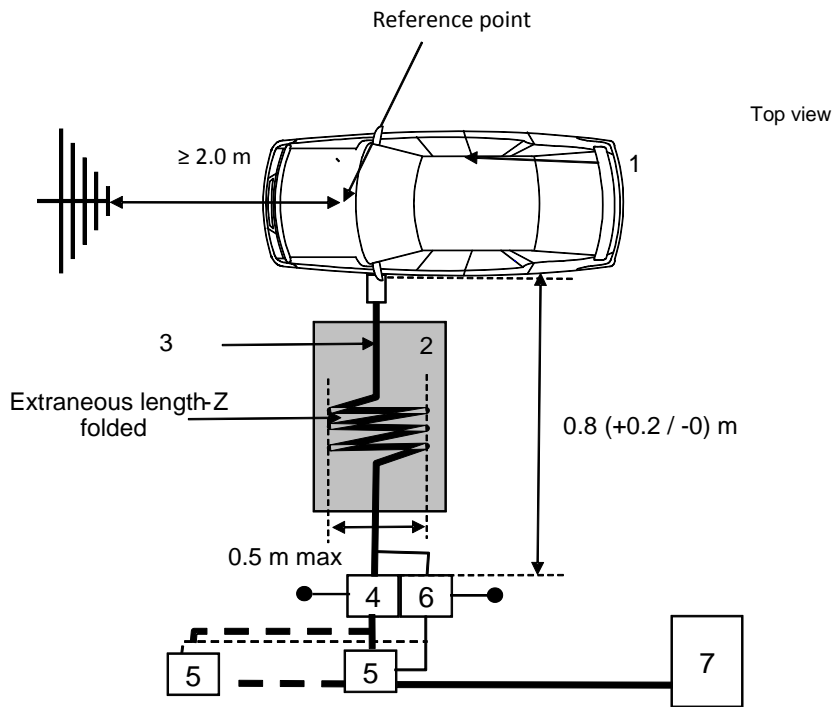

Figure 4f



Legend

- 1 Vehicle under test
- 2 Insulating support
- 3 Charging / communication cable
- 4 AC or DC Artificial Network(s) grounded
- 5 Power mains socket
- 6 Impedance Stabilisation(s) grounded
- 7 Charging Station

Example of test set-up for vehicle with plug located front / rear of the vehicle (AC or DC power charging with communication)

Figure 4g

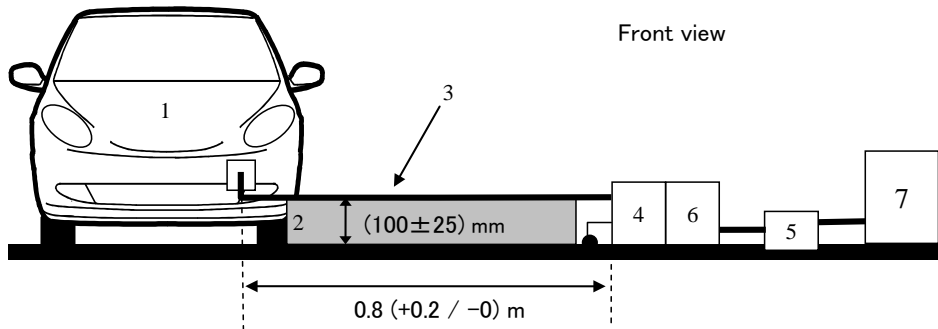
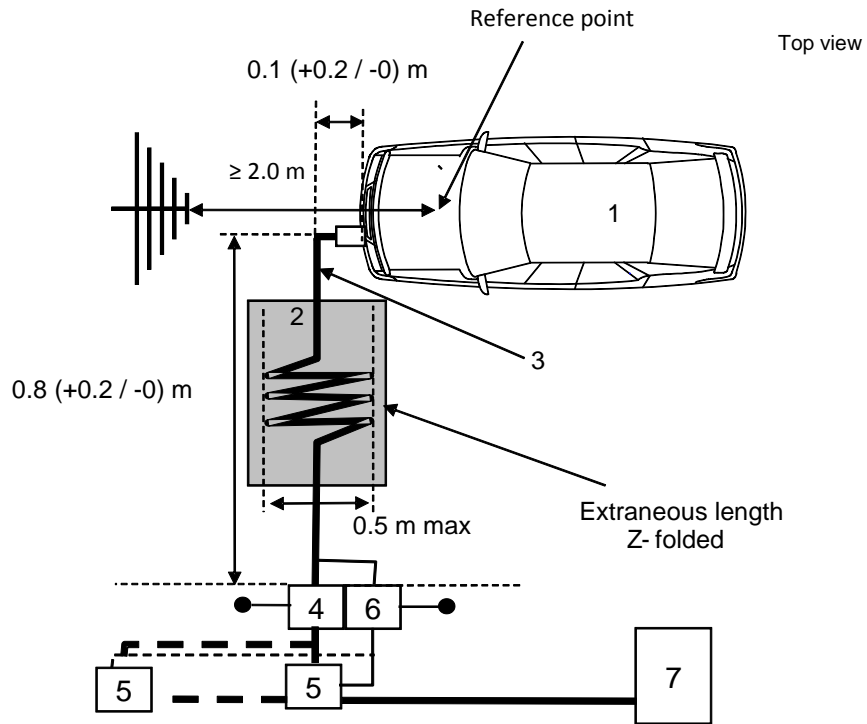

Figure 4h



Legend

- 1 Vehicle under test
- 2 Insulating support
- 3 Charging / communication cable
- 4 AC or DC Artificial Network(s) grounded
- 5 Power mains socket
- 6 Impedance Stabilisation(s) grounded
- 7 Charging Station

Annex 7, amend to read:

## "Annex 7

### **Method of measurement of radiated broadband electromagnetic emissions from electrical/electronic sub-assemblies (ESAs)**

1. General
  - 1.1. The test method described in this annex may be applied to ESAs, which may be subsequently fitted to vehicles, which comply with Annex 4.

This method concerns both kinds of ESA:

    - (a) Other ESAs than involved in "REESS charging mode coupled to the power grid".
    - (b) ESAs involved in "REESS charging mode coupled to the power grid".
  - 1.2. Test method

This test is intended to measure broadband electromagnetic emissions from ESAs (e.g. ignition systems, electric motor, onboard battery charging unit, etc.)

If not otherwise stated in this annex the test shall be performed according CISPR 25.
2. ESA state during tests
  - 2.1. The ESA under test shall be in normal operation mode, preferably in maximum load.

ESAs involved in "REESS charging mode coupled to the power grid" shall be in charging mode.

The state of charge (SOC) of the traction battery shall be kept between 20 per cent and 80 per cent of the maximum SOC during the whole frequency range measurement (this may lead to split the measurement in different sub-bands with the need to discharge the vehicle's traction battery before starting the next sub-bands)

If the test is not performed with a REESS the ESA should be tested at rated current. If the current consumption can be adjusted, then the current shall be set to at least 80 per cent of its nominal value.
3. Test arrangements
  - 3.1. For ESA other than involved in "REESS charging mode coupled to the power grid" the test shall be performed according to the ALSE method described in clause 6.4. of CISPR 25.
  - 3.2. For ESAs in configuration "REESS charging mode coupled to the power grid" the test arrangement shall be according to Figure 2 of the appendix to Annex 7.
    - 3.2.1. The shielding configuration shall be according to the vehicle series configuration. Generally all shielded HV parts shall be properly connected

with low impedance to ground (e. g. AN, cables, connectors etc.). ESAs and loads shall be connected to ground. The external HV power supply shall be connected via feed-through-filtering.

- 3.2.2. Unless otherwise specified the length of the LV harness and the HV harness parallel to the front edge of the ground plane shall be 1,500 mm ( $\pm 75$  mm). The total length of the test harness including the connector shall be 1,700 mm (+300/-0 mm). The distance between the LV harness and the HV harness shall be 100 mm (+100/-0 mm).
- 3.2.3. All of the harnesses shall be placed on a non-conductive, low relative permittivity material ( $\epsilon_r \leq 1.4$ ), at 50 mm ( $\pm 5$  mm) above the ground plane.
- 3.2.4. Shielded supply lines for HV+ and HV- line and three phase lines may be coaxial cables or in a common shield depending on the used plug system. The original HV-harness from the vehicle may be used optionally.
- 3.2.5. Unless otherwise specified, the ESA case shall be connected to the ground plane either directly or via defined impedance.
- 3.2.6. For onboard chargers, the AC/DC power lines shall be placed the furthest from the antenna (behind LV and HV harness). The distance between the AC/DC power lines and the closest harness (LV or HV) shall be 100 mm (+100/-0 mm).
- 3.3. Alternative measuring location  
As an alternative to an absorber lined shielded enclosure (ALSE) an open area test site (OATS), which complies with the requirements of CISPR 16-1-4 may be used (see appendix to this annex).
- 3.4. Ambient  
To ensure that there is no extraneous noise or signal of a magnitude sufficient to affect materially the measurement, measurements shall be taken before or after the main test. In this measurement, the extraneous noise or signal shall be at least 6 dB below the limits of interference given in paragraph 6.5.2.1. of this Regulation, except for intentional narrowband ambient transmissions.
- 4. Test requirements
  - 4.1. The limits apply throughout the frequency range 30 to 1,000 MHz for measurements performed in a semi anechoic chamber or an outdoor test site.
  - 4.2. Measurements can be performed with either quasi-peak or peak detectors. The limits given in paragraphs 6.2. and 6.5. of this Regulation are for quasi-peak detectors. If peak detectors are used a correction factor of 20 dB as defined in CISPR 12 shall be applied.
  - 4.3. The measurements shall be performed with a spectrum analyser or a scanning receiver. The parameters to be used are defined in Table 1 and Table 2.

Table 1  
**Spectrum analyser parameters**

Frequency range MHz	Peak detector		Quasi-peak detector		Average detector	
	RBW at -3 dB	Scan time	RBW at -6 dB	Scan time	RBW at -3 dB	Scan time
30 to 1,000	100/120 kHz	100 ms/MHz	120 kHz	20 s/MHz	100/120 kHz	100 ms/MHz

*Note:*

If a spectrum analyser is used for peak measurements, the video bandwidth shall be at least three times the resolution bandwidth (RBW).

Table 2  
**Scanning receiver parameters**

Frequency range MHz	Peak detector			Quasi-peak detector			Average detector		
	BW at -6 dB	Step size <sup>a</sup>	Dwell time	BW at -6 dB	Step size <sup>a</sup>	Dwell time	BW at -6 dB	Step size <sup>a</sup>	Dwell time
30 to 1,000	120 kHz	50 kHz	5 ms	120 kHz	50 kHz	1 s	120 kHz	50 kHz	5 ms

<sup>a</sup> For purely broadband disturbances, the maximum frequency step size may be increased up to a value not greater than the bandwidth value.

*Note:*

For emissions generated by brush commutator motors without an electronic control unit, the maximum step size may be increased up to five times the bandwidth.

#### 4.4. Measurements

Unless otherwise specified the configuration with the LV harness closer to the antenna shall be tested.

The phase centre of the antenna shall be in line with the centre of the longitudinal part of the wiring harnesses for frequencies up to 1,000 MHz.

The Technical Service shall perform the test at the intervals specified in the CISPR 12 standard throughout the frequency range 30 to 1,000 MHz.

Alternatively, if the manufacturer provides measurement to data for the whole frequency band from a test laboratory accredited to the applicable parts of ISO 17025 and recognized by the Type Approval Authority, the Technical Service may divide the frequency range in 14 frequency bands 30–34, 34–45, 45–60, 60–80, 80–100, 100–130, 130–170, 170–225, 225–300, 300–400, 400–525, 525–700, 700–850 and 850– 1,000 MHz and perform tests at the 14 frequencies giving the highest emission levels within each band to confirm that the ESA meets the requirements of this annex.

In the event that the limit is exceeded during the test, investigations shall be made to ensure that this is due to the ESA and not to background radiation.

#### 4.5. Readings

The maximum of the readings relative to the limit (horizontal/vertical polarization) in each of the 14 frequency bands shall be taken as the characteristic reading at the frequency at which the measurements were made."

Annex 7, Appendix, insert a new Figure 2, to read:

"Figure 2  
**Test configuration for ESAs involved in "REESS charging mode coupled to the power grid" (example for biconical antenna)**

Top view (horizontal polarization)

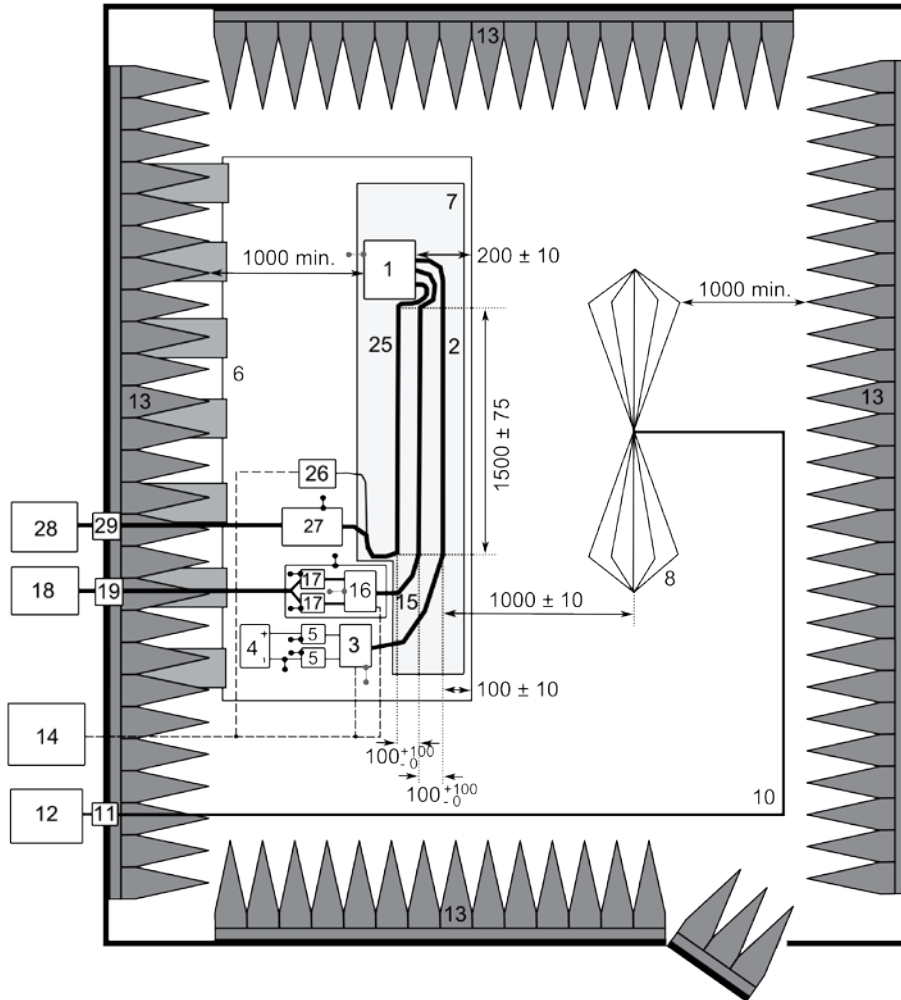

Legend:

- |   |                                      |
|---|--------------------------------------|
| 1 ESA (grounded locally if required in test plan)   | 14 Stimulation and monitoring system |
| 2 LV Test harness   | 15 HV harness                        |
| 3 LV Load simulator (placement and ground connection according to CISPR 25 paragraph 6.4.2.5) | 16 HV load simulator                 |
| 4 Power supply (location optional)  | 17 HV AN                             |
| 5 LV Artificial network (AN)  | 18 HV power supply                   |
| 6 Ground plane (bonded to shielded enclosure)   | 19 HV feed-through                   |
| 7 Low relative permittivity support ( $\epsilon_r \leq 1.4$ )                                 | 25 AC/DC charger harness             |
| 8 Biconical antenna   | 26 AC/DC load simulator (e.g. PLC)   |
| 10 High-quality coaxial cable e.g. double-shielded (50 $\Omega$ )                             | 27 50 $\mu$ H LISN (AC) or HVAN (DC) |
| 11 Bulkhead connector   | 28 AC/DC power supply                |
| 12 Measuring instrument   | 29 AC/DC feed-through                |
| 13 RF absorber material   |                                      |

Annex 8, amend to read:

## "Annex 8

### **Method of measurement of radiated narrowband electromagnetic emissions from electrical/electronic sub-assemblies**

1. General
  - 1.1. The test method described in this annex may be applied to ESAs, which may be subsequently fitted to vehicles, which comply, with Annex 5.

This method concerns only ESA other than those involved in "REESS charging mode coupled to the power grid".
  - 1.2. Test method

This test is intended to measure the narrowband electromagnetic emissions such as might emanate from a microprocessor-based system.

If not otherwise stated in this annex the test shall be performed according to CISPR 25.
2. ESA state during tests

The ESA under test shall be in normal operation mode, preferably in maximum load.
3. Test arrangements
  - 3.1. The test shall be performed according to ALSE method described in clause 6.4. of CISPR 25.
  - 3.2. Alternative measuring location

As an alternative to an absorber lined shielded enclosure (ALSE) an open area test site (OATS) which complies with the requirements of CISPR 16-1-4 may be used (see Figure 1 of the appendix to Annex 7).
  - 3.3. Ambient

To ensure that there is no extraneous noise or signal of a magnitude sufficient to affect materially the measurement, measurements shall be taken before or after the main test. In this measurement, the extraneous noise or signal shall be at least 6 dB below the limits of interference given in paragraph 6.6.2.1. of this Regulation, except for intentional narrowband ambient transmissions.
4. Test requirements
  - 4.1. The limits apply throughout the frequency range 30 to 1,000 MHz for measurements performed in semi anechoic chambers or outdoor test sites.
  - 4.2. Measurements shall be performed with an average detector.
  - 4.3. The measurements shall be performed with a spectrum analyser or a scanning receiver. The parameters to be used are defined in Tables 1 and 2.

Table 1  
Spectrum analyser parameters

Frequency range MHz	Peak detector		Quasi-peak detector		Average detector	
	RBW at -3 dB	Scan time	RBW at -6 dB	Scan time	RBW at -3 dB	Scan time
30 to 1,000	100/120 kHz	100 ms/MHz	120 kHz	20 s/MHz	100/120 kHz	100 ms/MHz

Note:

If a spectrum analyser is used for peak measurements, the video band width shall be at least three times the resolution band width (RBW)

Table 2  
Scanning receiver parameters

Frequency range MHz	Peak detector			Quasi-peak detector			Average detector		
	BW at -6 dB	Step size <sup>a</sup>	Dwell time	BW at -6 dB	Step size <sup>a</sup>	Dwell time	BW at -6 dB	Step size <sup>a</sup>	Dwell time
30 to 1,000	120 kHz	50 kHz	5 ms	120 kHz	50 kHz	1 s	120 kHz	50 kHz	5 ms

<sup>a</sup> For purely broadband disturbances, the maximum frequency step size may be increased up to a value not greater than the bandwidth value.

Note:

For emissions generated by brush commutator motors without an electronic control unit, the maximum step size may be increased up to five times the band width.

#### 4.4. Measurements

The Technical Service shall perform the test at the intervals specified in the CISPR 12 standard throughout the frequency range 30 to 1,000 MHz.

Alternatively, if the manufacturer provides measurement to data for the whole frequency band from a test laboratory accredited to the applicable parts of ISO 17025 and recognized by the Type Approval Authority, the Technical Service may divide the frequency range in 14 frequency bands 30–34, 34–45, 45–60, 60–80, 80–100, 100–130, 130–170, 170–225, 225–300, 300–400, 400–525, 525–700, 700–850 and 850–1,000 MHz and perform tests at the 14 frequencies giving the highest emission levels within each band to confirm that the ESA meets the requirements of this annex. In the event that the limit is exceeded during the test, investigations shall be made to ensure that this is due to the ESA and not to background radiation including broadband radiation from the ESA.

#### 4.5. Readings

The maximum of the readings relative to the limit (horizontal/vertical polarisation) in each of the 14 frequency bands shall be taken as the characteristic reading at the frequency at which the measurements were made."



Annex 9, amend to read:

## "Annex 9

### **Method(s) of testing for immunity of electrical/electronic sub-assemblies to electromagnetic radiation**

1. General
  - 1.1. The test method(s) described in this annex applies to ESAs.
  - 1.2. Test methods
 

This method concerns both kinds of ESA:

    - (a) Other ESAs than involved in "REESS charging mode coupled to the power grid".
    - (b) ESAs involved in "REESS charging mode coupled to the power grid".
  - 1.2.1. ESAs may comply with the requirements of any combination of the following test methods at the manufacturer's discretion provided that these results in the full frequency range specified in paragraph 3.1. of this annex being covered:
    - (a) Absorber chamber test according to ISO 11452-2;
    - (b) TEM cell testing according to ISO 11452-3;
    - (c) Bulk current injection testing according to ISO 11452-4;
    - (d) Stripline testing according to ISO 11452-5;
    - (e) 800 mm stripline according to paragraph 5. of this annex.

ESAs in configuration "REESS charging mode coupled to the power grid" shall comply with the requirements of the combination of the Absorber chamber test according to ISO 11452-2 and Bulk current injection testing according to ISO 11452-4 at the manufacturer's discretion provided that these results in the full frequency range specified in paragraph 3.1. of this annex being covered.

(Frequency range and general test conditions shall be based on ISO 11452-1).
2. State of ESA during tests
  - 2.1. The test conditions shall be according ISO 11452-1.
  - 2.2. The ESA under test shall be switched on and shall be stimulated to be in normal operation condition. It shall be arranged as defined in this annex unless individual test methods dictate otherwise.
 

ESAs involved in "REESS charging mode coupled to the power grid" shall be in charging mode.

The state of charge (SOC) of the traction battery shall be kept between 20 per cent and 80 per cent of the maximum SOC during the whole frequency range measurement (this may lead to split the measurement in different sub-bands with the need to discharge the vehicle's traction battery before starting the next sub-bands).

If the test is not performed with a REESS the ESA should be tested at rated current. If the current consumption can be adjusted, then the current shall be set to at least 20 per cent of its nominal value.

2.3. Any extraneous equipment required to operate the ESA under test shall not be in place during the calibration phase. No extraneous equipment shall be closer than 1 m from the reference point during calibration.

2.4. To ensure reproducible measurement results are obtained when tests and measurements are repeated, the test signal generating equipment and its layout shall be to the same specification as that used during each appropriate calibration phase.

2.5. If the ESA under test consists of more than one unit, the interconnecting cables should ideally be the wiring harnesses as intended for use in the vehicle. If these are not available, the length between the electronic control unit and the AN shall be as defined in the standard. All cables in the wiring harness should be terminated as realistically as possible and preferably with real loads and actuators.

3. General test requirements

3.1. Frequency range, dwell times

Measurements shall be made in the 20 to 2,000 MHz frequency range with frequency steps according to ISO 11452-1.

The test signal modulation shall be:

- (a) AM (amplitude modulation), with 1 kHz modulation and 80 per cent modulation depth in the 20 to 800 MHz frequency range, and
- (b) PM (pulse modulation), Ton 577  $\mu$ s, period 4,600  $\mu$ s in the 800 to 2,000 MHz frequency range,

If not otherwise agreed between Technical Service and ESA manufacturer.

Frequency step size and dwell time shall be chosen according to ISO 11452-1.

3.2. The Technical Service shall perform the test at the intervals specified in ISO 11452-1, throughout the frequency range 20 to 2,000 MHz.

Alternatively, if the manufacturer provides measurement to data for the whole frequency band from a test laboratory accredited to the applicable parts of ISO 17025, and recognized by the Type Approval Authority, the Technical Service may choose a reduced number of spot frequencies in the range, e.g. 27, 45, 65, 90, 120, 150, 190, 230, 280, 380, 450, 600, 750, 900, 1,300, and 1,800 MHz to confirm that the ESA meets the requirements of this annex.

3.3. If an ESA fails the tests defined in this annex, it shall be verified as having failed under the relevant test conditions and not as a result of the generation of uncontrolled fields.

4. Specific test requirements

4.1. Absorber chamber test

4.1.1. Test method

This test method allows the testing of vehicle electrical/electronic systems by exposing an ESA to electromagnetic radiation generated by an antenna.

- 4.1.2. Test methodology
- The "substitution method" shall be used to establish the test field conditions according ISO 11452-2.
- The test shall be performed with vertical polarization.
- 4.1.2.1. For ESAs in configuration "REESS charging mode coupled to the power grid" the test arrangement shall be according to Appendix 3 to this annex.
- 4.1.2.1.1. The shielding configuration shall be according to the vehicle series configuration. Generally all shielded HV parts shall be properly connected with low impedance to ground (e. g. AN, cables, connectors etc.). ESAs and loads shall be connected to ground. The external HV power supply shall be connected via feed-through-filtering.
- 4.1.2.1.2. Unless otherwise specified the length of the LV harness and the HV harness parallel to the front edge of the ground plane shall be 1.500 mm ( $\pm 75$  mm). The total length of the test harness including the connector shall be 1,700 mm (+300/-0 mm). The distance between the LV harness and the HV harness shall be 100 mm (+100/-0 mm).
- 4.1.2.1.3. All of the harnesses shall be placed on a non-conductive, low relative permittivity material ( $\epsilon_r \leq 1,4$ ), at 50 mm ( $\pm 5$  mm) above the ground plane.
- 4.1.2.1.4. Shielded supply lines for HV+ and HV- line and three phase lines may be coaxial cables or in a common shield depending on the used plug system. The original HV-harness from the vehicle may be used optionally.
- 4.1.2.1.5. Unless otherwise specified, the ESA case shall be connected to the ground plane either directly or via defined impedance.
- 4.1.2.1.6. For onboard chargers, the AC/DC power lines shall be placed the furthest from the antenna (behind LV and HV harness). The distance between the AC/DC power lines and the closest harness (LV or HV) shall be 100 mm (+100/-0 mm).
- 4.1.2.1.7. Unless otherwise specified, the configuration with the LV harness closer to the antenna shall be tested.
- 4.2. TEM cell testing (see Appendix 2 to this annex)
- 4.2.1. Test method
- The TEM (transverse electromagnetic mode) cell generates homogeneous fields between the internal conductor (septum) and housing (ground plane).
- 4.2.2. Test methodology
- The test shall be performed according ISO 11452-3.
- Depending on the ESA to be tested the Technical Service shall chose the method of maximum field coupling to the ESA or to the wiring harness inside the TEM-cell.
- 4.3. Bulk current injection testing
- 4.3.1. Test method
- This is a method of carrying out immunity tests by inducing currents directly into a wiring harness using a current injection probe.

- 4.3.2. Test methodology
- The test shall be performed according to ISO 11452-4 on a test bench. As an alternative the ESA may be tested while installed in the vehicle according to ISO 11451-4 with the following characteristics:
- (a) The injection probe shall be positioned in 150 mm distance to the ESA to be tested;
  - (b) The reference method shall be used to calculate injected currents from forward power;
  - (c) The frequency range of the method is limited by the injection probe specification.
- 4.3.2.1. For ESAs in configuration "REESS charging mode coupled to the power grid", the test arrangement shall be according to Appendix 4 to this annex.
- 4.3.2.1.1. The shielding configuration shall be according to the vehicle series configuration. Generally all shielded HV parts shall be properly connected with low impedance to ground (e. g. AN, cables, connectors, etc.). ESAs and loads shall be connected to ground. The external HV power supply shall be connected via feed-through-filtering.
- 4.3.2.1.2. Unless otherwise specified the length of the LV harness and the HV harness shall be 1,700 mm (+300/-0 mm). The distance between the LV harness and the HV harness shall be 100 mm (+100/-0 mm).
- 4.3.2.1.3. All of the harnesses shall be placed on a non-conductive, low relative permittivity material ( $\epsilon_r \leq 1.4$ ), at  $(50 \pm 5)$  mm above the ground plane.
- 4.3.2.1.4. Shielded supply lines for HV+ and HV- line and three phase lines may be coaxial cables or in a common shield depending on the used plug system. The original HV-harness from the vehicle may be used optionally.
- 4.3.2.1.5. Unless otherwise specified, the ESA case shall be connected to the ground plane either directly or via defined impedance.
- 4.3.2.1.6. Unless otherwise specified the test shall be performed with the injection probe placed around each of the following harnesses:
- (a) Low voltage harness;
  - (b) High voltage harness;
  - (c) AC power lines if applicable;
  - (d) DC power lines if applicable.
- 4.4. Stripline testing
- 4.4.1. Test method
- This test method consists of subjecting the wiring harness connecting the components in an ESA to specified field strengths.
- 4.4.2. Test methodology
- The test shall be performed according to ISO 11452-5.
- 4.5. 800 mm striplining testing

#### 4.5.1. Test method

The stripline consists of two parallel metallic plates separated by 800 mm. Equipment under test is positioned centrally between the plates and subjected to an electromagnetic field (see Appendix 1 to this annex).

This method can test complete electronic systems including sensors and actuators as well as the controller and wiring loom. It is suitable for apparatus whose largest dimension is less than one-third of the plate separation.

#### 4.5.2. Test methodology

##### 4.5.2.1. Positioning of stripline

The stripline shall be housed in a screened room (to prevent external emissions) and positioned 2 m away from walls and any metallic enclosure to prevent electromagnetic reflections. RF absorber material may be used to damp these reflections. The stripline shall be placed on non-conducting supports at least 0.4 m above the floor.

##### 4.5.2.2. Calibration of the stripline

A field-measuring probe shall be positioned within the central one-third of the longitudinal, vertical and transverse dimensions of the space between the parallel plates with the system under test absent.

The associated measuring equipment shall be sited outside the screen room. At each desired test frequency, a level of power shall be fed into the stripline to produce the required field strength at the antenna. This level of forward power, or another parameter directly related to the forward power required to define the field, shall be used for type approval tests unless changes occur in the facilities or equipment, which necessitate this procedure being repeated.

##### 4.5.2.3. Installation of the ESA under test

The main control unit shall be positioned within the central one third of the longitudinal, vertical and transverse dimensions of the space between the parallel plates. It shall be supported on a stand made from non-conducting material.

##### 4.5.2.4. Main wiring loom and sensor/actuator cables

The main wiring loom and any sensor/actuator cables shall rise vertically from the control unit to the top ground plate (this helps to maximize coupling with the electromagnetic field). Then they shall follow the underside of the plate to one of its free edges where they shall loop over and follow the top of the ground plate as far as the connections to the stripline feed. The cables shall then be routed to the associated equipment, which shall be sited in an area outside the influence of the electromagnetic field, e.g. on the floor of the screened room 1 m longitudinally away from the stripline."

Annex 9, insert a new Appendix 3, to read:

### "Annex 9 – Appendix 3

Absorber chamber test

Test configuration for ESA's involved in "REESS charging mode coupled to the power grid". The test shall be performed according to ISO 11452-2.

Top view (Vertical polarization)

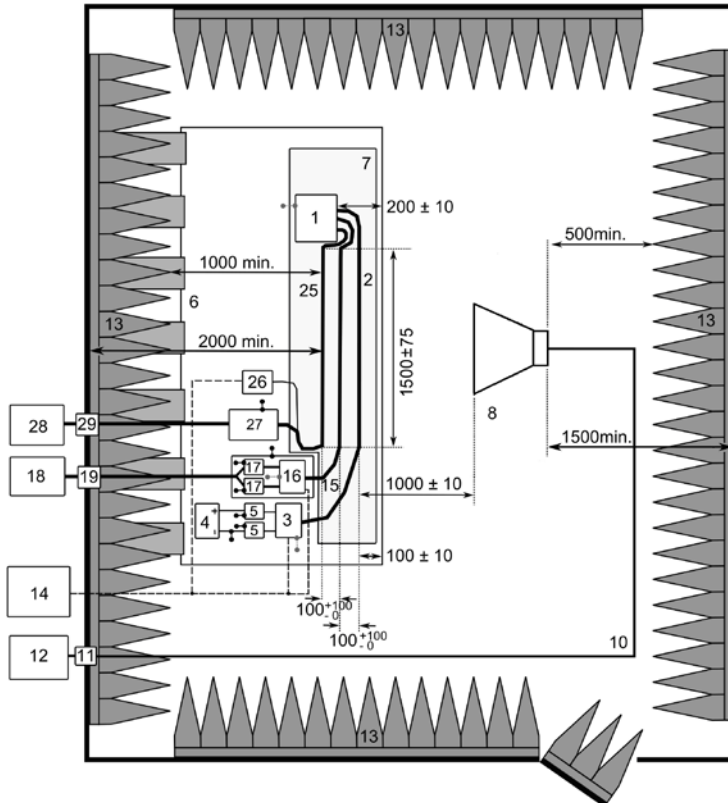

Legend:

- |   |   |
|---|---|
| 1 ESA (grounded locally if required in test plan)   | 14 Stimulation and monitoring system      |
| 2 LV Test harness   | 15 HV harness                             |
| 3 LV Load simulator (placement and ground connection according to CISPR 25 paragraph 6.4.2.5) | 16 HV load simulator                      |
| 4 Power supply (location optional)  | 17 HV AN                                  |
| 5 LV Artificial network (AN)  | 18 HV power supply                        |
| 6 Ground plane (bonded to shielded enclosure)   | 19 HV feed-through                        |
| 7 Low relative permittivity support ( $\epsilon_r \leq 1.4$ )                                 | 25 AC/DC charger harness                  |
| 8 Horn antenna  | 26 AC/DC load simulator (e.g. PLC)        |
| 10 High-quality coaxial cable e.g. double-shielded ( $50 \Omega$ )                            | 27 $50\mu\text{H}$ LISN (AC) or HVAN (DC) |
| 11 Bulkhead connector   | 28 AC/DC power supply                     |
| 12 RF signal generator and amplifier  | 29 AC/DC feed-through                     |
| 13 RF absorber material   |   |

"

Annex 9, insert a new Appendix 4, to read:

"Annex 9 – Appendix 4

BCI test

Test configuration for ESAs involved in "REESS charging mode coupled to the power grid". The test shall be performed according to ISO 11452-4.

Top view (example of substitution method)

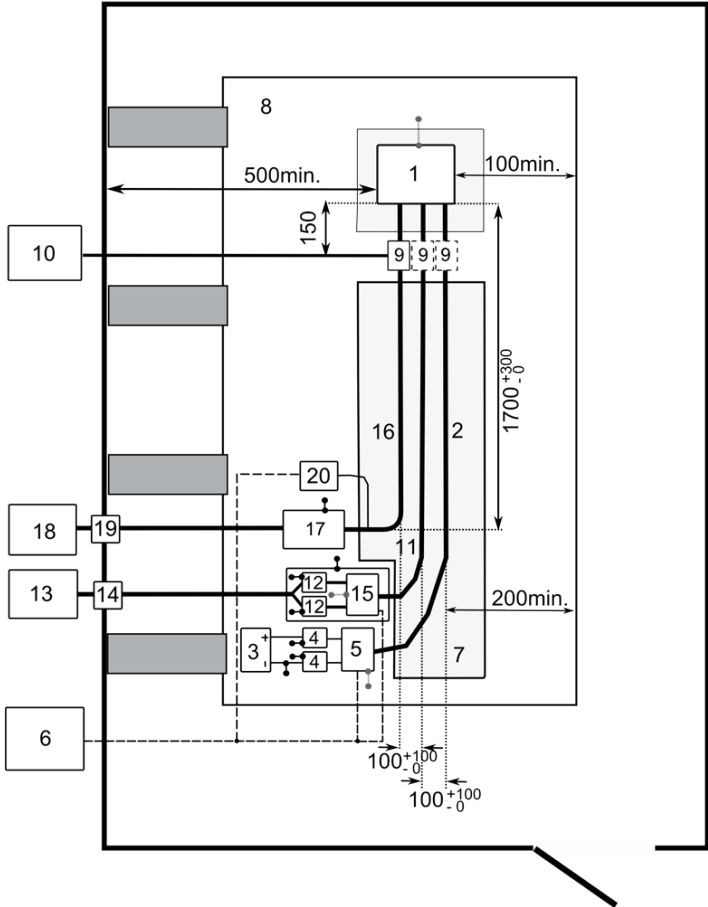

Legend:

- 1 ESA (grounded locally if required in test plan)
- 2 LV Test harness
- 3 LV supply
- 4 LV LISN
- 5 LV load simulator
- 6 Stimulation and monitoring system
- 7 Low relative permittivity support
- 8 Ground plane
- 9 Injection probe
- 10 RF signal amplifier and generator
- 11 HV DC harness
- 12 HV AN
- 13 HV DC load
- 14 HV DC feed-through
- 15 HV DC load simulator
- 16 HV AC/DC charger harness
- 17 50 μH LISN (AC) or HV AN (DC)
- 18 HV AC/DC power supply
- 19 HV AC/DC feed-through
- 20 HV AC/DC load simulator (e.g. PLC)

Annex 10, amend to read:

## "Annex 10

### **Method(s) of testing for immunity to and emission of transients of electrical/electronic sub-assemblies**

1. General  
This test method shall ensure the immunity of ESAs to conducted transients on the vehicle power supply and limit conducted transients from ESAs to the vehicle power supply.
2. Immunity against transient disturbances conducted along 12/24 V supply lines.  
Apply the test pulses 1, 2a, 2b, 3a, 3b and 4 according to the International Standard ISO 7637-2 to the supply lines as well as to other connections of ESAs which may be operationally connected to supply lines.
3. Emission of transient conducted disturbances generated by ESAs on 12/24 V supply lines  
Measurement according to the International Standard ISO 7637-2 on supply lines as well as to other connections of ESAs which may be operationally connected to supply lines."

Annex 11, amend to read:

## "Annex 11

### **Method(s) of testing for emission of harmonics generated on AC power lines from vehicle**

1. General
  - 1.1. The test method described in this annex shall be applied to vehicles in configuration "REESS charging mode coupled to the power grid"
  - 1.2. Test method  
This test is intended to measure the level of harmonics generated by vehicle in configuration "REESS charging mode coupled to the power grid" through its AC power lines in order to ensure it is compatible with residential, commercial and light industrial environments.  
If not otherwise stated in this annex the test shall be performed according to:
    - (a) IEC 61000-3-2 for input current in charging mode  $\leq 16$  A per phase for class A equipment,
    - (b) IEC 61000-3-12 for input current in charging mode  $> 16$  A and  $\leq 75$  A per phase.
2. Vehicle state during tests
  - 2.1. The vehicle shall be in configuration "REESS charging mode coupled to the power grid".



The state of charge (SOC) of the traction battery shall be kept between 20 per cent and 80 per cent of the maximum SOC during the whole time duration of the measurement (this may lead to the measurement being split into different time slots with the need to discharge the vehicle's traction battery before starting the next time slot). If the current consumption can be adjusted, then the current shall be set to at least 80 per cent of its nominal value.

The vehicle shall be immobilized, engine OFF.

And all other equipment which can be switched on permanently by the driver or passenger should be OFF.

3. Test arrangements
  - 3.1. The observation time to be used for the measurements shall be as for quasi-stationary equipment as defined in IEC 61000-3-2, Table 4.
  - 3.2. The test set-up for single phase vehicle in configuration "REESS charging mode coupled to the power grid" is shown in Figure 1 of the appendix to this annex.
  - 3.3. The test set-up for three-phase vehicle in configuration "REESS charging mode coupled to the power grid" is shown in Figure 2 of the appendix to this annex.
4. Test requirements
  - 4.1. The measurements of even and odd current harmonics shall be performed up to the 40th harmonic.
  - 4.2. The limits for single phase or three-phase "REESS charging mode coupled to the power grid" with input current  $\leq 16$  A per phase are given in Table 3 of paragraph 7.3.2.1.
  - 4.3. The limits for single phase "REESS charging mode coupled to the power grid" with input current  $> 16$  A and  $\leq 75$  A per phase are given in Table 4 of paragraph 7.3.2.2.
  - 4.4. The limits for three-phase "REESS charging mode coupled to the power grid" with input current  $> 16$  A and  $\leq 75$  A per phase are given in Table 5 of paragraph 7.3.2.2.
  - 4.5. For three-phase "REESS charging mode coupled to the power grid" with input current  $> 16$  A and  $\leq 75$  A per phase, when at least one of the three conditions a), b) or c) described in clause 5.2. of IEC 61000-3-12 is fulfilled, then the limits given in Table 6 of paragraph 7.3.2.2. can be applied."

Annex 11, Appendix, amend to read:

**"Annex 11 – Appendix**

Figure 1  
**Vehicle in configuration "REESS charging mode coupled to the power grid" – Single phase charger test set-up**

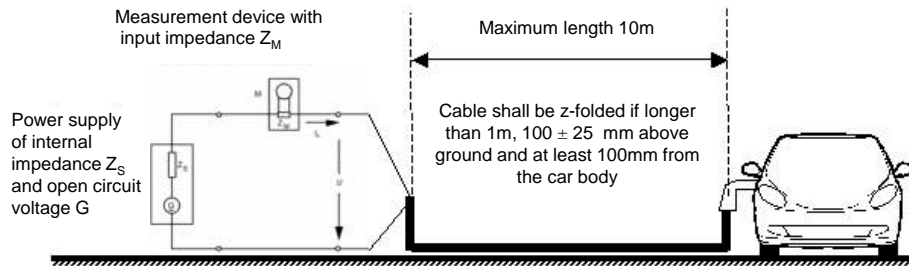
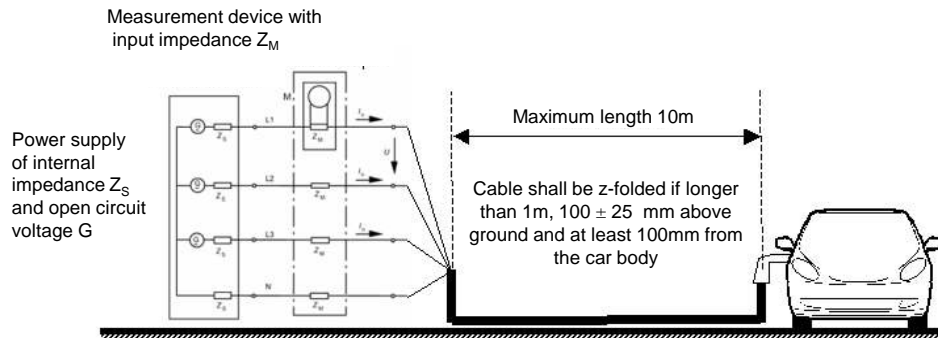

Figure 2  
**Vehicle in configuration "REESS charging mode coupled to the power grid" – Three-phase charger test set-up**



Annex 12, amend to read:

## "Annex 12

### **Method(s) of testing for emission of voltage changes, voltage fluctuations and flicker on AC power lines from vehicle**

1. General
  - 1.1. The test method described in this annex shall be applied to vehicles in configuration "REESS charging mode coupled to the power grid"
  - 1.2. Test method
 

This test is intended to measure the level of voltage changes, voltage fluctuations and flicker generated by vehicle in configuration "REESS charging mode coupled to the power grid" through its AC power lines in order to ensure it is compatible with residential, commercial and light industrial environments.

If not otherwise stated in this annex the test shall be performed according to:

    - (a) IEC 61000-3-3 for rated current in "REESS charging mode"  $\leq 16$  A per phase and not subjected to conditional connection;
    - (b) IEC 61000-3-11 for rated current in "REESS charging mode"  $> 16$  A and  $\leq 75$  A per phase and subjected to conditional connection.
2. Vehicle state during tests
  - 2.1. The vehicle shall be in configuration "REESS charging mode coupled to the power grid".
 

The state of charge (SOC) of the traction battery shall be kept between 20 per cent and 80 per cent of the maximum SOC during the whole time duration of the measurement (this may lead to the measurement being split into different time slots with the need to discharge the vehicle's traction battery before starting the next time slot).. If the current consumption can be adjusted, then the current shall be set to at least 80 per cent of its nominal value.

The vehicle shall be immobilized, engine OFF.

And all other equipment which can be switched on permanently by the driver or passenger should be OFF.
3. Test arrangements
  - 3.1. The tests for vehicle in configuration "REESS charging mode coupled to the power grid" with rated current  $\leq 16$  A per phase and not subjected to conditional connection shall be performed according to paragraph 4. of IEC 61000-3-3.
  - 3.2. The tests for vehicle in configuration "REESS charging mode coupled to the power grid" with rated current  $> 16$  A and  $\leq 75$  A per phase and subjected to conditional connection shall be performed according to paragraph 6. of IEC 61000-3-11.
  - 3.3. The test set-up for vehicle in configuration "REESS charging mode coupled to the power grid" is shown in Figures 1a and 1b of the appendix to this annex.

4. Test requirements
- 4.1. The parameters to be determined in the time-domain are "short duration flicker value", "long duration flicker value" and "voltage relative variation".
- 4.2. The limits for vehicle in configuration "REESS charging mode coupled to the power grid" with input current  $\leq 16$  A per phase and not subjected to conditional connection are given in paragraph 7.4.2.1.
- 4.3. The limits for vehicle in configuration "REESS charging mode coupled to the power grid" with input current  $> 16$  A and  $\leq 75$  A per phase and subjected to conditional connection are given in paragraph 7.4.2.2."

Annex 12, Appendix, amend to read:

"Annex 12 – Appendix

Figure 1a  
Vehicle in configuration "REESS charging mode coupled to the power grid" – Single phase test set-up

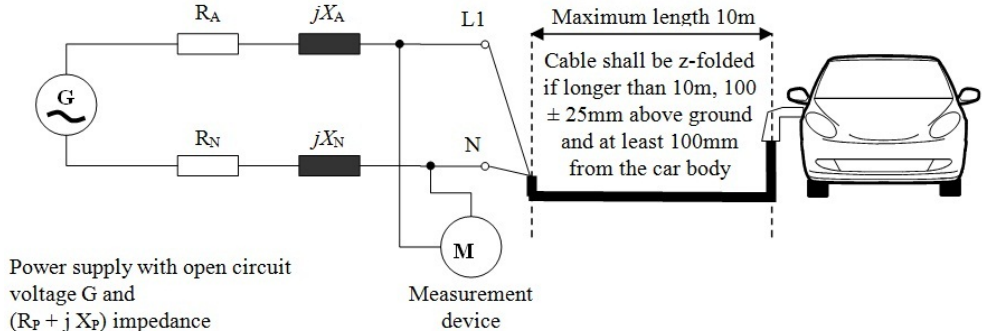
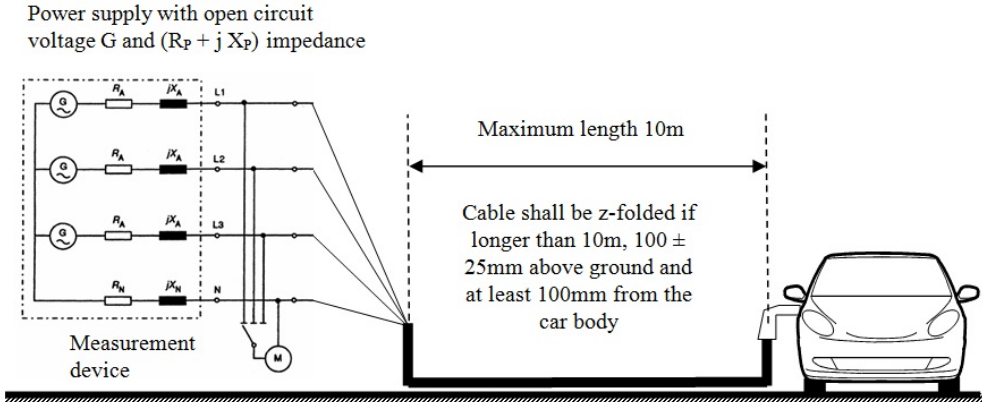

Figure 1b  
Vehicle in configuration "REESS charging mode coupled to the power grid" – Three phase test set-up



Annex 13, amend to read:

## "Annex 13

### **Method(s) of testing for emission of radiofrequency conducted disturbances on AC or DC power lines from vehicles**

1. General
  - 1.1. The test method described in this annex shall be applied to vehicles in configuration "REESS charging mode coupled to the power grid".
  - 1.2. Test method

This test is intended to measure the level of radio frequency conducted disturbances generated by vehicle in configuration "REESS charging mode coupled to the power grid" through its AC or DC power lines in order to ensure it is compatible with residential, commercial and light industrial environments.

If not otherwise stated in this annex the test shall be performed according to CISPR 16-2-1.
2. Vehicle state during tests
  - 2.1. The vehicle shall be in configuration "REESS charging mode coupled to the power grid".

The state of charge (SOC) of the traction battery shall be kept between 20 per cent and 80 per cent of the maximum SOC during the whole frequency range measurement (this may lead to split the measurement in different sub-bands with the need to discharge the vehicle's traction battery before starting the next sub-bands). If the current consumption can be adjusted, then the current shall be set to at least 80 per cent of its nominal value.

The vehicle shall be immobilized, engine OFF.

And all other equipment which can be switched on permanently by the driver or passenger should be OFF.
3. Test arrangements
  - 3.1. The test shall be performed according to clause 7.4.1. of CISPR 16-2-1 as floor-standing equipment.
  - 3.2. The artificial mains network to be used for the measurement on vehicle is defined in clause 4.3. of CISPR 16-1-2.

Artificial networks

The AN(s) shall be mounted directly on the ground plane. The cases of the AN(s) shall be bonded to the ground plane.

The measuring port of each AN shall be terminated with a 50  $\Omega$  load.

The AN shall be placed as defined in Figures 1a to 1d.
  - 3.3. The test set-up for the connection of the vehicle in configuration "REESS charging mode coupled to the power grid" is shown in Figure 1a to 1d of the appendix to this annex.

- 3.4. The measurements shall be performed with a spectrum analyser or a scanning receiver. The parameters to be used are defined in Table 1 and Table 2.

Table 1  
Spectrum analyser parameters

Frequency range MHz	Peak detector		Quasi-peak detector		Average detector	
	RBW at -3 dB	Scan time	RBW at -6 dB	Scan time	RBW at -3 dB	Scan time
0.15 to 30	9/10 kHz	10 s/MHz	9 kHz	200 s/MHz	9/10 kHz	10 s/MHz

Note:

If a spectrum analyser is used for peak measurements, the video bandwidth shall be at least three times the resolution bandwidth (RBW)

Table 2  
Scanning receiver parameters

Frequency range MHz	Peak detector			Quasi-peak detector			Average detector		
	BW at -6 dB	Step size <sup>a</sup>	Dwell time	BW at -6 dB	Step size <sup>a</sup>	Dwell time	BW at -6 dB	Step size <sup>a</sup>	Dwell time
0.15 to 30	9 kHz	5 kHz	50 ms	9 kHz	5 kHz	1 s	9 kHz	5 kHz	50 ms

<sup>a</sup> For purely broadband disturbances, the maximum frequency step size may be increased up to a value not greater than the bandwidth value.

4. Test Requirements
- 4.1. The limits apply throughout the frequency range 0.15 to 30 MHz for measurements performed in a semi anechoic chamber or an outdoor test site.
- 4.2. Measurements shall be performed with average and either quasi-peak or peak detectors. The limits are given in paragraph 7.5.

Table 7 for AC lines and Table 8 for DC lines. If peak detectors are used a correction factor of 20 dB as defined in CISPR 12 shall be applied."

Annex 13, Appendix, amend to read:

"Annex 13 – Appendix

Figure 1  
**Vehicle in configuration "REESS charging mode coupled to the power grid"**

Example of test setup for vehicle with plug located on vehicle side (AC powered without communication)

Figure 1a

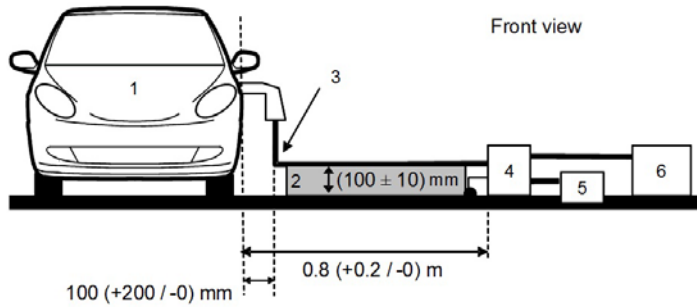
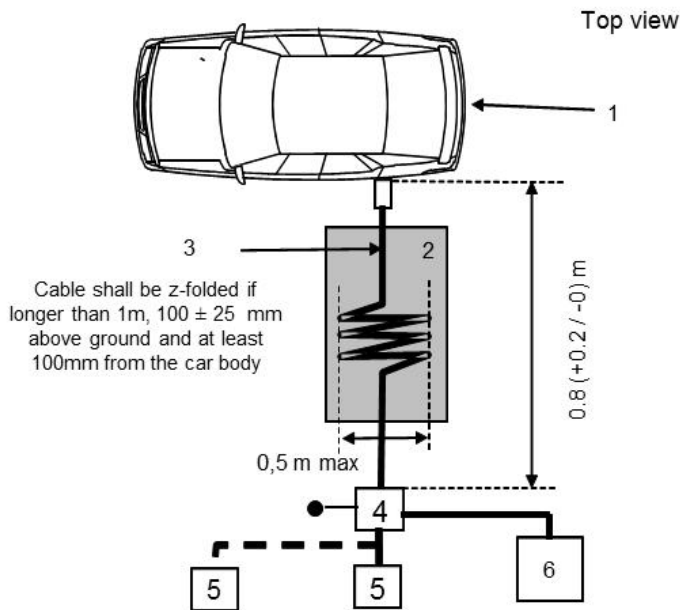

Figure 1b



Legend

- 1 Vehicle under test
- 2 Insulating support
- 3 Charging cable
- 4 Artificial Network(s) grounded (for AC or DC power lines)
- 5 Power mains socket
- 6 Measuring receiver



Vehicle in configuration "REESS charging mode coupled to the power grid"

Example of test setup for vehicle with plug located front / rear of vehicle (AC powered without communication)

Figure 1c

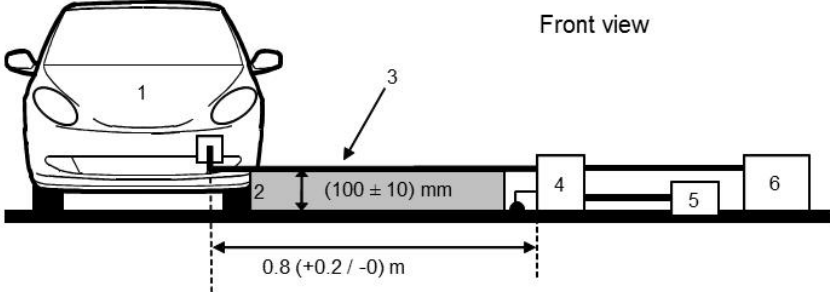
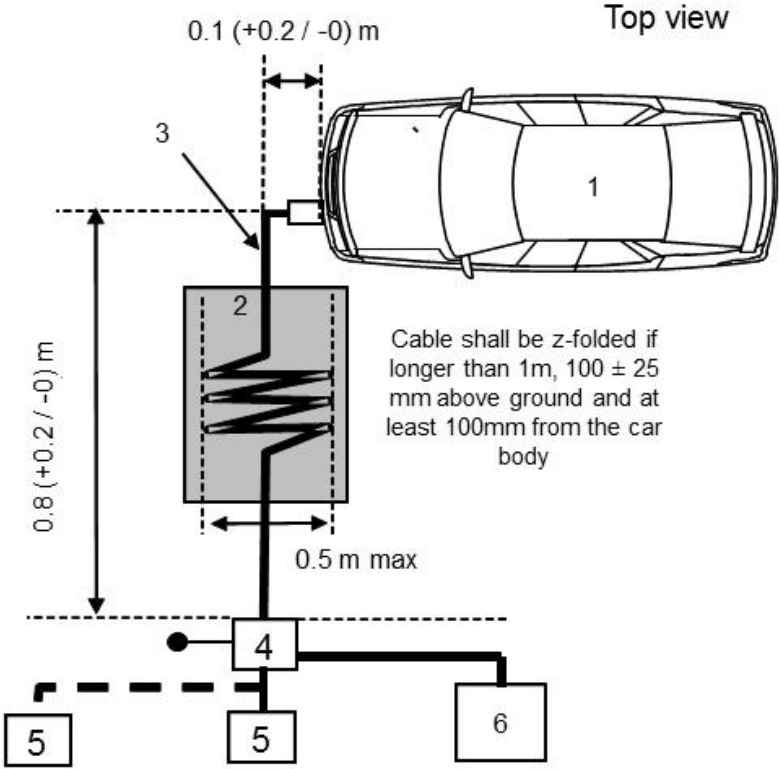

Figure 1d



Legend

- 1 Vehicle under test
- 2 Insulating support
- 3 Charging cable
- 4 Artificial Network(s) grounded (for AC or DC power lines)
- 5 Power mains socket
- 6 Measuring receiver

Annex 14, amend to read:

## "Annex 14

### **Method(s) of testing for emission of radiofrequency conducted disturbances on network and telecommunication access from vehicles**

1. General
  - 1.1. The test method described in this annex shall be applied to vehicles in configuration "REESS charging mode coupled to the power grid".
  - 1.2. Test method

This test is intended to measure the level of radio frequency conducted disturbances generated by vehicle in configuration "REESS charging mode coupled to the power grid" through its network and telecommunication access in order to ensure it is compatible with residential, commercial and light industrial environments.

If not otherwise stated in this annex the test shall be performed according to CISPR 22.
2. Vehicle/ state during tests
  - 2.1. The vehicle shall be in configuration "REESS charging mode coupled to the power grid". The state of charge (SOC) of the traction battery shall be kept between 20 per cent and 80 per cent of the maximum SOC during the whole frequency range measurement (this may lead to split the measurement in different sub-bands with the need to discharge the vehicle's traction battery before starting the next sub-bands). If the current consumption can be adjusted, then the current shall be set to at least 80 per cent of its nominal value.

The vehicle shall be immobilized, engine OFF.

And all other equipment which can be switched on permanently by the driver or passenger should be OFF.
3. Test arrangements
  - 3.1. The test set-up shall be performed according to paragraph 5. of CISPR 22 for conducted emissions.
  - 3.2. The impedance stabilisation to be used for the measurement on vehicle is defined in paragraph 9.6.2. of CISPR 22.

**Impedance Stabilization**

Communication lines shall be applied to the vehicle through IS(s).

The IS(s) shall be mounted directly on the ground plane. The case of the IS(s) shall be bonded to the ground plane.

The measuring port of each IS shall be terminated with a 50  $\Omega$  load. The IS shall be placed as defined in Figures 1a to 1d.

- 3.3. The test set-up for the connection of the vehicle in configuration "REESS charging mode coupled to the power grid" is shown in Figures 1a to 1d of the appendix to this annex.

If it is impossible to guarantee the functionality of vehicle, due to introduction of IS, an alternate method described in CISPR 22 (according to Figures 2a to 2d of this annex) shall be applied.

- 3.4. The measurements shall be performed with a spectrum analyser or a scanning receiver. The parameters to be used are defined in Table 1 and Table 2.

Table 1  
Spectrum analyser parameters

Frequency range MHz	Peak detector		Quasi-peak detector		Average detector	
	RBW at -3 dB	Scan time	RBW at -6 dB	Scan time	RBW at -3 dB	Scan time
0.15 to 30	9/10 kHz	10 s/MHz	9 kHz	200 s/MHz	9/10 kHz	10 s/MHz

Note:

If a spectrum analyser is used for peak measurements, the video bandwidth shall be at least three times the resolution bandwidth (RBW)

Table 2  
Scanning receiver parameters

Frequency range MHz	Peak detector			Quasi-peak detector			Average detector		
	BW at -6 dB	Step size <sup>a</sup>	Dwell time	BW at -6 dB	Step size <sup>a</sup>	Dwell time	BW at -6 dB	Step size <sup>a</sup>	Dwell time
0.15 to 30	9 kHz	5 kHz	50 ms	9 kHz	5 kHz	1 s	9 kHz	5 kHz	50 ms

<sup>a</sup> For purely broadband disturbances, the maximum frequency step size may be increased up to a value not greater than the bandwidth value.

4. Test Requirements
- 4.1. The limits apply throughout the frequency range 0.15 to 30 MHz for measurements performed in a semi anechoic chamber or an outdoor test site.
- 4.2. Measurements shall be performed with average and either quasi-peak or peak detectors. The limits are given in Table 9 of paragraph 7.6. If peak detectors are used a correction factor of 20 dB as defined in CISPR 12 shall be applied."

Annex 14, Appendix, amend to read:

## "Annex 14 – Appendix

Figure 1

### Vehicle in configuration "REESS charging mode coupled to the power grid"

Example of test setup for vehicle with plug located on vehicle side (AC or DC powered with communication)

Figure 1a

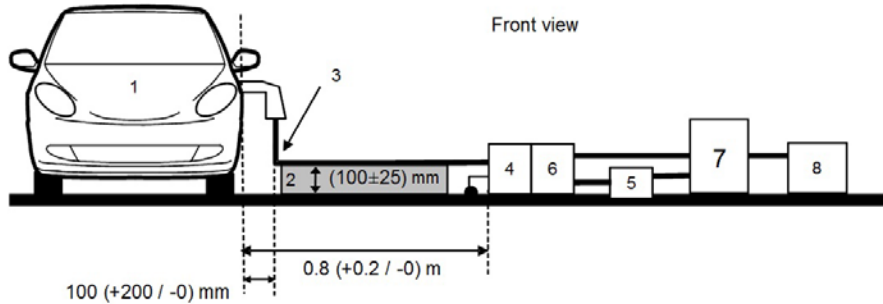
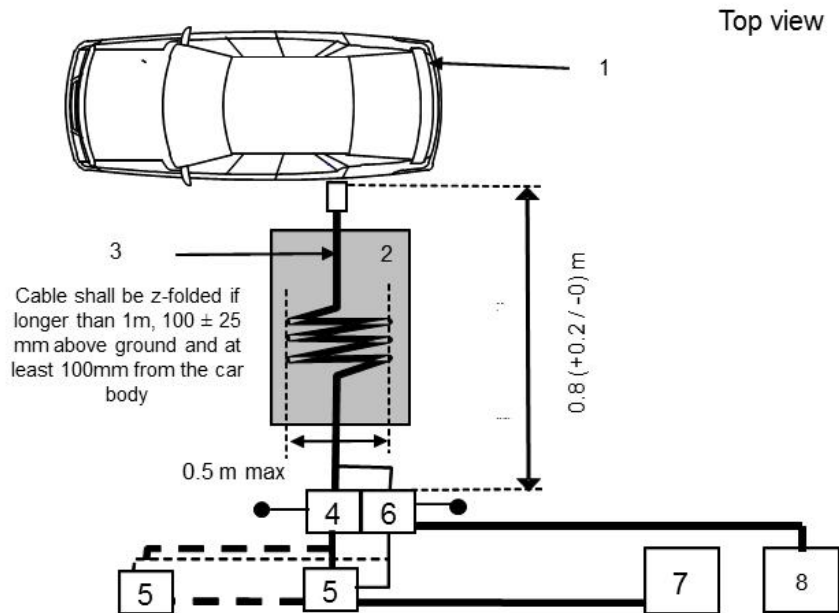

Figure 1b



#### Legend

- |  |   |
|--|---|
| 1 Vehicle under test   | 5 Power mains socket  |
| 2 Insulating support   | 6 Impedance Stabilization(s) grounded (for communication lines) |
| 3 Charging / communication cable                                     | 7 Charging Station  |
| 4 AC or DC Artificial Network(s) grounded (for AC or DC power lines) | 8 Measuring receiver  |

Vehicle in configuration "REESS charging mode coupled to the power grid"

Example of test set-up for vehicle with plug located front/rear of vehicle (AC or DC powered with communication)

Figure 1c

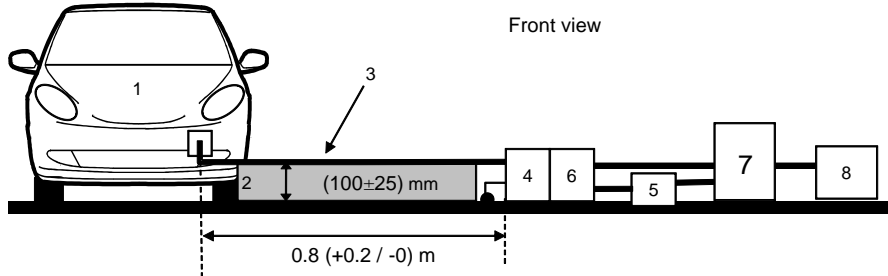
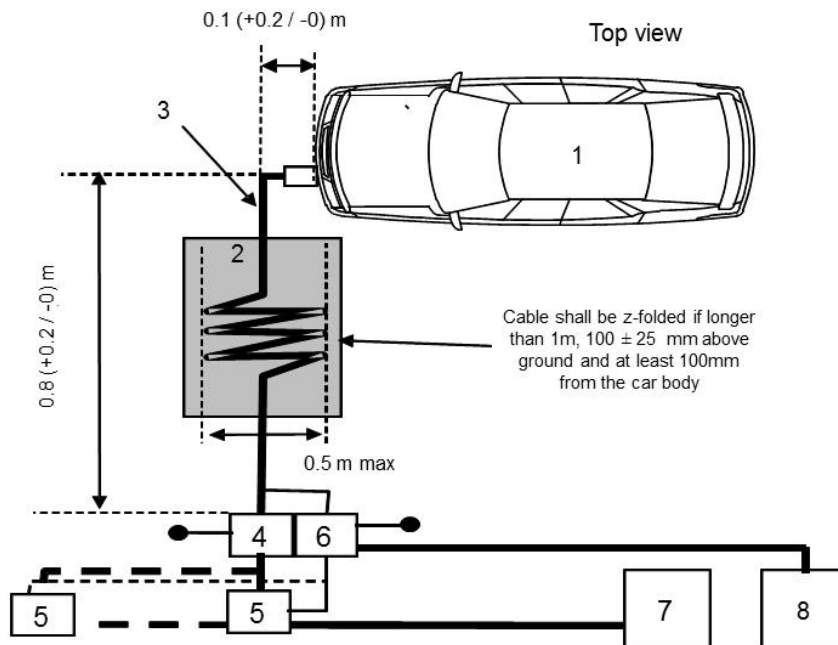

Figure 1d



Legend

- |  |   |
|--|---|
| 1 Vehicle under test   | 5 Power mains socket  |
| 2 Insulating support   | 6 Impedance Stabilization(s) grounded (for communication lines) |
| 3 Charging / communication cable                                     | 7 Charging Station  |
| 4 AC or DC Artificial Network(s) grounded (for AC or DC power lines) | 8 Measuring receiver  |

Figure 2  
**Alternative measurement for vehicle in configuration "REESS charging mode coupled in the power grid"**

Example of test setup for vehicle with plug located on vehicle side (AC or DC powered with communication)

Figure 2a

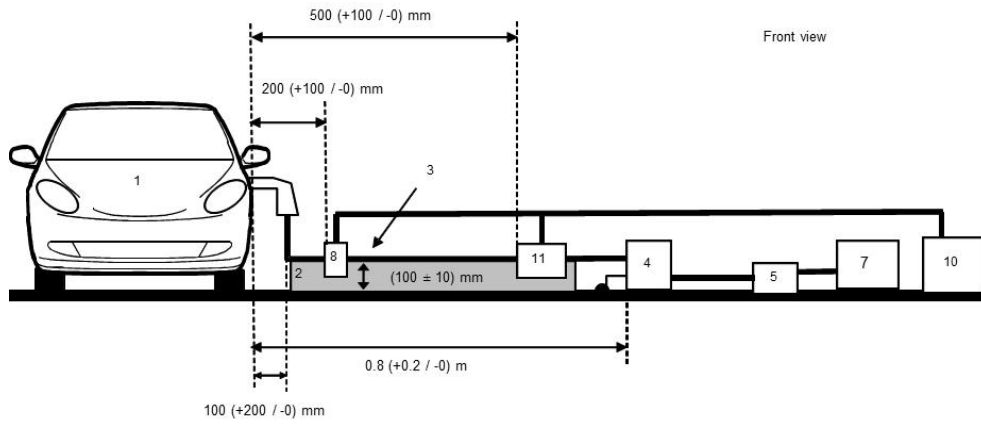
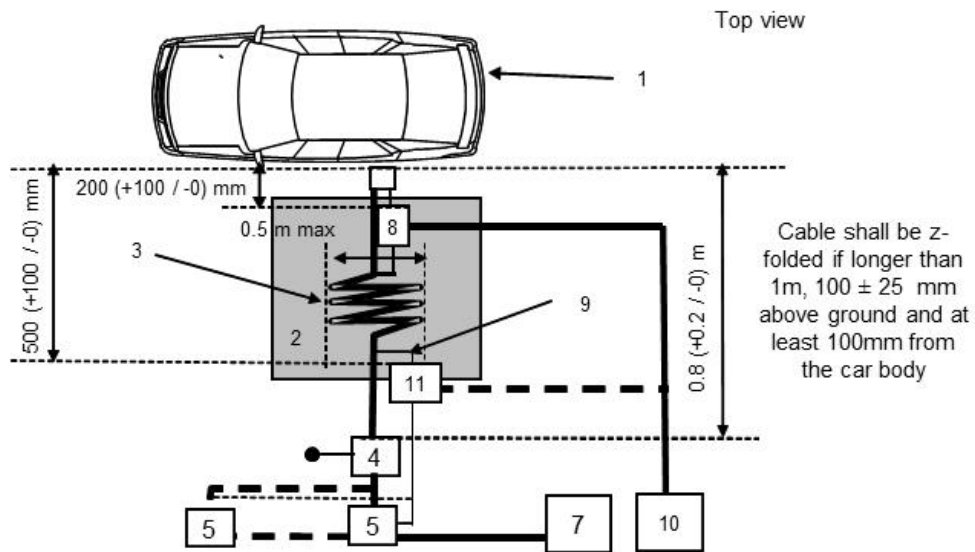

Figure 2b



Legend

- |  |                             |
|--|-----------------------------|
| 1 Vehicle under test   | 7 Charging Station          |
| 2 Insulating support   | 8 Current probe             |
| 3 Charging / communication cable                                     | 9 Communication lines       |
| 4 AC or DC Artificial Network(s) grounded (for AC or DC power lines) | 10 Measuring receiver       |
| 5 Power mains socket   | 11 Capacitive voltage probe |

Alternative measurement for vehicle in configuration "REESS charging mode coupled in the power grid"

Example of test setup for vehicle with plug located front / rear of vehicle (AC or DC powered with communication)

Figure 2c

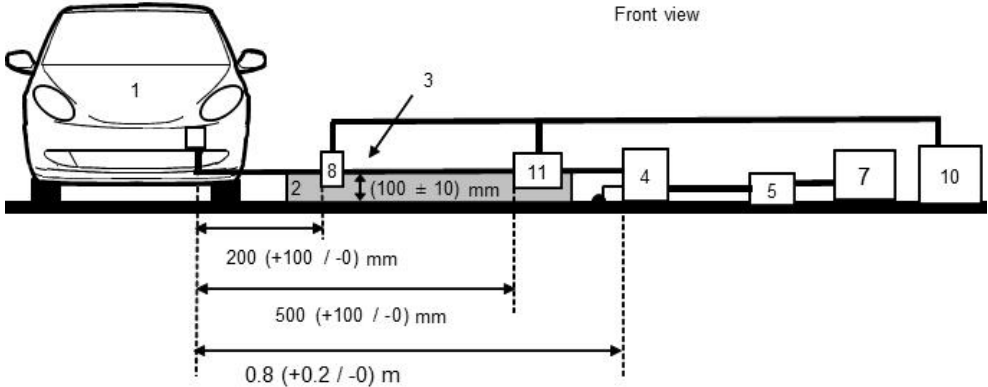
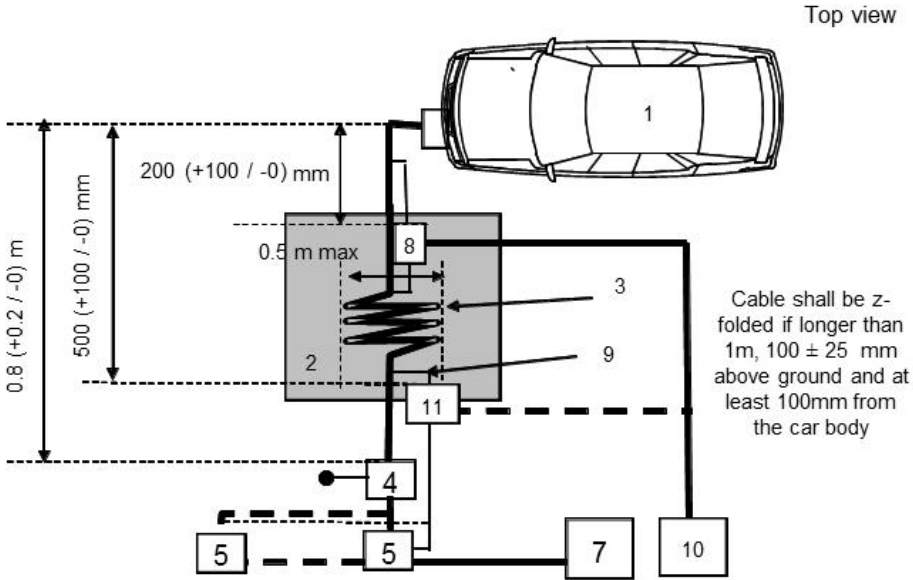

Figure 2d



Legend

- 1 Vehicle under test
- 2 Insulating support
- 3 Charging / communication cable
- 4 AC or DC Artificial Network(s) grounded (for AC or DC power lines)
- 5 Power mains socket
- 7 Charging Station
- 8 Current probe (or capacitive voltage probe)
- 9 Communication lines
- 10 Measuring receiver
- 11 Capacitive voltage probe

Annex 15, amend to read:

**"Annex 15**

**Method of testing for immunity of vehicles to electrical fast transient/burst disturbances conducted along AC and DC power lines**

- 1. General
  - 1.1. The test method described in this annex shall only be applied to vehicles. This method concerns only the configuration of the vehicle with "REESS charging mode coupled to the power grid".
  - 1.2. Test method
 

This test is intended to demonstrate the immunity of the vehicle electronic systems. The vehicle shall be subject to electrical fast transient/burst disturbances conducted along AC and DC power lines of the vehicle as described in this annex. The vehicle shall be monitored during the tests.

If not otherwise stated in this annex the test shall be performed according to IEC 61000-4-4.
- 2. Vehicle state during tests in configuration "REESS in charging mode coupled to the power grid"
  - 2.1. The vehicle shall be in an unladen condition except for necessary test equipment.
    - 2.1.1. The vehicle shall be immobilized, engine OFF and in charging mode.
    - 2.1.2. Basic vehicle conditions
 

The paragraph defines minimum test conditions (as far as applicable) and failures criteria for vehicle immunity tests. Other vehicle systems, which can affect immunity related functions, shall be tested in a way to be agreed between manufacturer and Technical Service.

<i>"REESS charging mode" vehicle test conditions</i>	<i>Failure criteria</i>
The REESS shall be in charging mode. The state of charge (SOC) of the traction battery shall be kept between 20 per cent and 80 per cent of the maximum SOC during the whole time duration of the measurement (this may lead to the measurement being split into different time slots with the need to discharge the vehicle's traction battery before starting the next time slot). If the current consumption can be adjusted, then the current shall be set to at least 20 per cent of its nominal value.	Vehicle sets in motion

- 2.1.3. All other equipment which can be switched on permanently by the driver or passenger should be OFF.
- 2.2. Only non-perturbing equipment shall be used while monitoring the vehicle. The vehicle exterior and the passenger compartment shall be monitored to determine whether the requirements of this annex are met (e.g. by using (a) video camera(s), a microphone, etc.).



3. Test equipment
  - 3.1. The test equipment is composed of a reference ground plane (a shielded room is not required), a transient/burst generator, coupling/decoupling network (CDN) and capacitive coupling clamp.
  - 3.2. The transient/burst generator shall meet the condition defined in paragraph 6.1. of IEC 61000-4-4.
  - 3.3. The coupling/decoupling network shall meet the condition defined in paragraph 6.2. of IEC 61000-4-4. When the coupling/decoupling network cannot be used on AC or DC power lines, the capacitive coupling clamp defined in paragraph 6.3. of IEC 61000-4-4 can be used.
4. Test Setup
  - 4.1. The vehicle test setup is based on the laboratory type setup as described in paragraph 7.2. of IEC 61000-4-4.
  - 4.2. The vehicle shall be placed directly on the ground plane.
  - 4.3. The Technical Service shall perform the test as specified in paragraph 7.7.2.1. Alternatively, if the manufacturer provides measurement from a test laboratory accredited to the applicable parts of ISO 17025 and recognized by the Type Approval Authority, the Technical Service may choose not to perform the test to confirm that the vehicle meets the requirements of this annex.
5. Generation of required Test Level
  - 5.1. Test methodology
    - 5.1.1. The test method according to IEC 61000-4-4 shall be used to establish the test level requirements.
    - 5.1.2. Test phase

The vehicle shall be positioned on the ground plane. The electrical fast transient/burst (EFT/B) shall be applied on the vehicle on the AC/DC power lines in common modes by using CDN as described in Figure 1 of the appendix to this annex.

The test set-up shall be noted in the test report."

Annex 15, Appendix, amend to read:

## "Annex 15 – Appendix

Figure 1  
Vehicle in configuration "REESS charging mode" coupled to the power grid coupling on AC/DC power lines

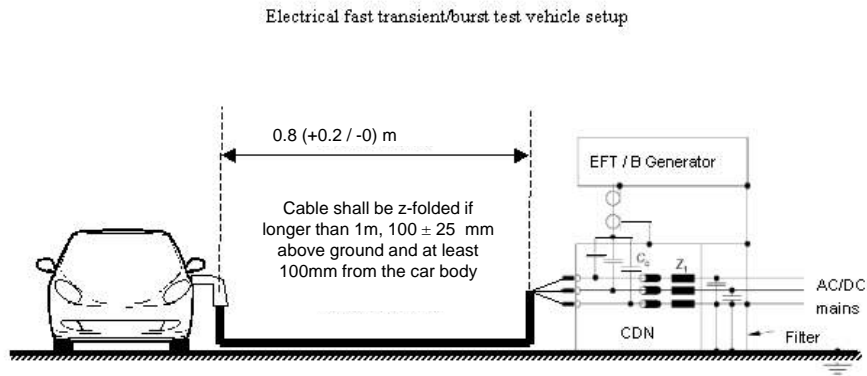

"

Annex 16, amend to read:

## "Annex 16

### Method of testing for immunity of vehicles to surges conducted along AC and DC power lines

1. General
  - 1.1. The test method described in this annex shall only be applied to vehicles. This method concerns only the configuration of the vehicle with "REESS charging mode coupled to the power grid".
  - 1.2. Test method
 

This test is intended to demonstrate the immunity of the vehicle electronic systems. The vehicle shall be subject to surges conducted along AC and DC power lines of the vehicle as described in this annex. The vehicle shall be monitored during the tests.

If not otherwise stated in this annex the test shall be performed according to IEC 61000-4-5.
2. Vehicle state during tests in configuration "REESS in charging mode coupled to the power grid"
  - 2.1. The vehicle shall be in an unladen condition except for necessary test equipment.
    - 2.1.1. The vehicle shall be immobilized, engine OFF and in charging mode.
    - 2.1.2. Basic vehicle conditions
 

The paragraph defines minimum test conditions (as far as applicable) and failures criteria for vehicle immunity tests. Other vehicle systems, which can affect immunity related functions, shall be tested in a way to be agreed between manufacturer and Technical Service.

<i>"REESS charging mode" vehicle test conditions</i>	<i>Failure criteria</i>
The REESS shall be in charging mode. The state of charge (SOC) of the traction battery shall be kept between 20 per cent and 80 per cent of the maximum SOC during the whole time duration of the measurement (this may lead to the measurement being split into different time slots with the need to discharge the vehicle's traction battery before starting the next time slot).. If the current consumption can be adjusted, then the current shall be set to at least 20 per cent of its nominal value.	Vehicle sets in motion

- 2.1.3. All other equipment which can be switched on permanently by the driver or passenger should be OFF.
- 2.2. Only non-perturbing equipment shall be used while monitoring the vehicle. The vehicle exterior and the passenger compartment shall be monitored to determine whether the requirements of this annex are met (e.g. by using (a) video camera(s), a microphone, etc.).
3. Test equipment
  - 3.1. The test equipment is composed of a reference ground plane (a shielded room is not required), a surge generator and a coupling/decoupling network (CDN).

- 3.2. The surge generator shall meet the condition defined in paragraph 6.1. of IEC 61000-4-5.
- 3.3. The coupling/decoupling network shall meet the condition defined in paragraph 6.3. of IEC 61000-4-5.
- 4. Test setup
  - 4.1. The vehicle test setup is based on the setup described in paragraph 7.2. of IEC 61000-4-5.
  - 4.2. The vehicle shall be placed directly on the ground plane.
  - 4.3. The Technical Service shall perform the test as specified in paragraph 7.8.2.1. Alternatively, if the manufacturer provides measurement from a test laboratory accredited to the applicable parts of ISO 17025 and recognized by the Type Approval Authority, the Technical Service may choose not to perform the test to confirm that the vehicle meets the requirements of this annex.
- 5. Generation of required test level
  - 5.1. Test methodology
    - 5.1.1. The test method according to IEC 61000-4-5 shall be used to establish the test level requirements.
    - 5.1.2. Test phase

The vehicle shall be positioned on the ground plane. The electrical surge shall be applied on the vehicle on the AC/DC power lines between each line and earth and between lines by using CDN as described in Figures 1 to 4 of the appendix to this annex,

The test setup shall be noted in the test report."

Annex 16, Appendix, amend to read:

## "Annex 16 – Appendix

Vehicle in configuration "REESS charging mode coupled to the power grid

Figure 1

Vehicle in configuration "REESS charging mode coupled to the power grid" – Coupling between lines for DC or AC (single phase) power lines

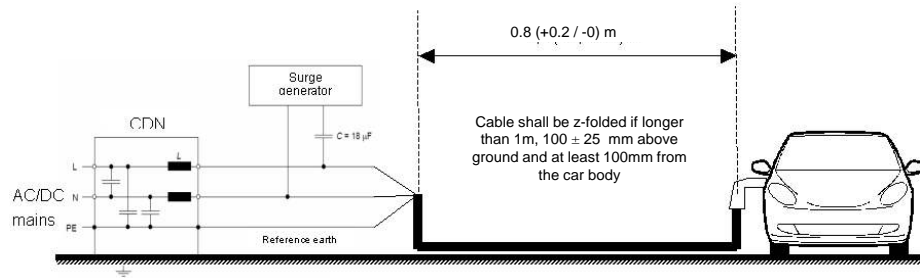

Figure 2

Vehicle in configuration "REESS charging mode coupled to the power grid" – Coupling between each line and earth for DC or AC (single phase) power lines

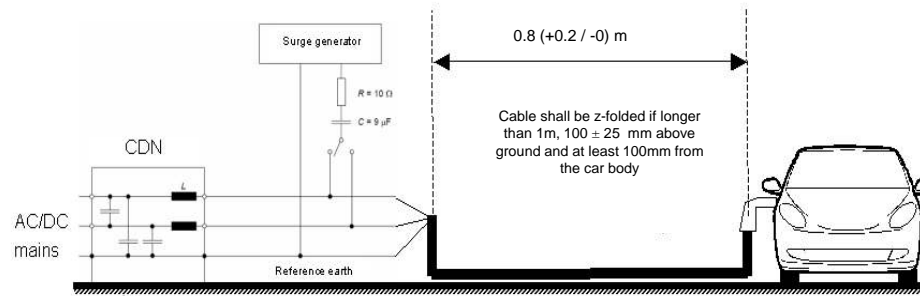

Figure 3  
**Vehicle in configuration "REESS charging mode coupled to the power grid" – Coupling between lines for AC (three phases) power lines**

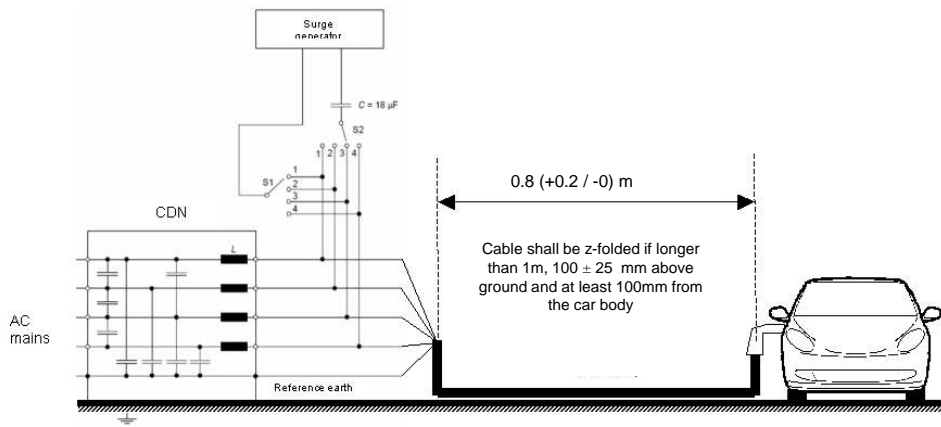
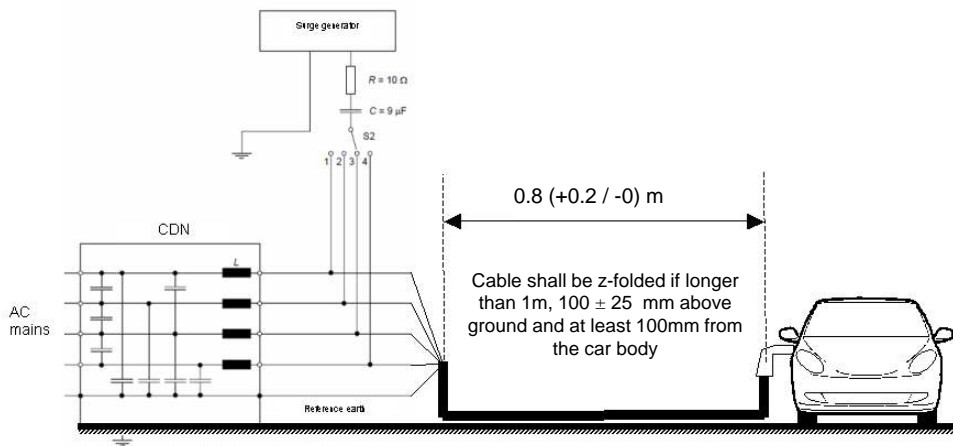

Figure 4  
**Vehicle in configuration "REESS charging mode coupled to the power grid" – Coupling between each line and earth for AC (three phases) power lines**



Insert new Annexes 17 to 22 and their Appendices, to read:

## "Annex 17

### **Method(s) of testing for emission of harmonics generated on AC power lines from an ESA**

1. General
  - 1.1. The test method described in this annex shall be applied to ESAs in configuration "REESS charging mode coupled to the power grid"
  - 1.2. Test method
 

This test is intended to measure the level of harmonics generated by an ESA in configuration "REESS charging mode coupled to the power grid" through its AC power lines in order to ensure it is compatible with residential, commercial and light industrial environments.

If not otherwise stated in this annex the test shall be performed according to:

    - (a) IEC 61000-3-2 for input current in charging mode  $\leq 16$  A per phase for class A equipment;
    - (b) IEC 61000-3-12 for input current in charging mode  $> 16$  A and  $\leq 75$  A per phase.
2. ESA state during tests
  - 2.1. The ESA shall be in configuration "REESS charging mode coupled to the power grid".
 

The state of charge (SOC) of the traction battery shall be kept between 20 per cent and 80 per cent of the maximum SOC during the whole time duration of the measurement (this may lead to the measurement being split into different time slots with the need to discharge the vehicle's traction battery before starting the next time slot)..

If the current consumption can be adjusted, then the current shall be set to at least 80 per cent of its nominal value.
3. Test arrangements
  - 3.1. The observation time to be used for the measurements shall be as for quasi-stationary equipment as defined in Table 4 of IEC 61000-3-2.
  - 3.2. The test set-up for single phase ESA in configuration "REESS charging mode coupled to the power grid" is shown in Figure 1 of the appendix to this annex.
  - 3.3. The test set-up for three-phase ESA in configuration "REESS charging mode coupled to the power grid" is shown in Figure 2 of the appendix to this annex.
4. Test requirements
  - 4.1. The measurements of even and odd current harmonics shall be performed up to the 40th harmonic.
  - 4.2. The limits for single phase or three-phase ESAs in configuration "REESS charging mode coupled to the power grid" with input current  $\leq 16$  A per phase are given in Table 10 of paragraph 7.11.2.1.

- 4.3. The limits for single phase ESAs in configuration "REESS charging mode coupled to the power grid" with input current  $> 16$  A and  $\leq 75$  A per phase are given in Table 11 of paragraph 7.11.2.2.
- 4.4. The limits for three-phase ESAs in configuration "REESS charging mode coupled to the power grid" with input current  $> 16$  A and  $\leq 75$  A per phase are given in paragraph Table 12 of 7.11.2.2.
- 4.5. For three-phase ESAs in configuration "REESS charging mode coupled to the power grid" with input current  $> 16$  A and  $\leq 75$  A per phase, when at least one of the three conditions a), b) or c) described in clause 5.2. of IEC 61000-3-12 is fulfilled, then the limits given in Table 13 of paragraph 7.11.2.2. can be applied.



### Annex 17 – Appendix

Figure 1  
ESA in configuration "REESS charging mode coupled to the power grid" – Single phase test set-up

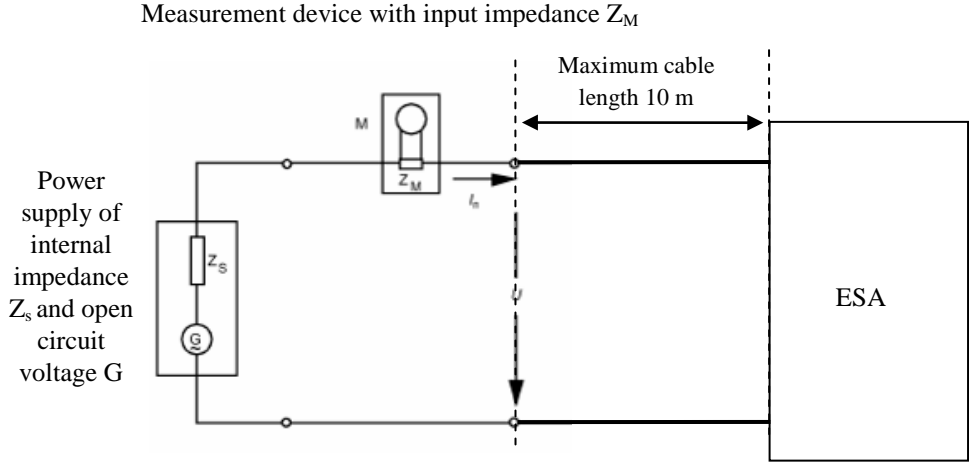
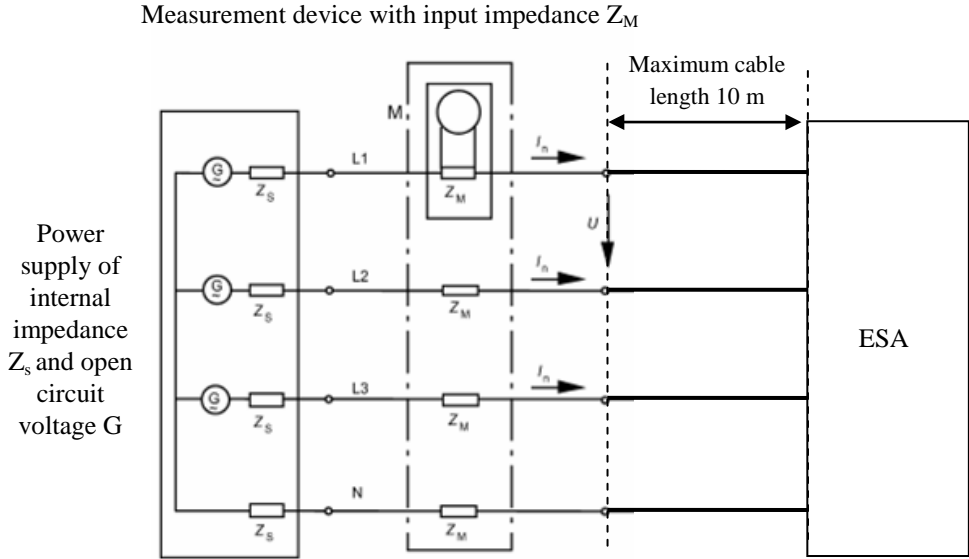

Figure 2  
ESA in configuration "REESS charging mode coupled to the power grid" – Three-phase-test set-up



## Annex 18

### Method(s) of testing for emission of voltage changes, voltage fluctuations and flicker on AC power lines from an ESA

1. General
  - 1.1. The test method described in this annex shall be applied to ESAs in configuration "REESS charging mode coupled to the power grid"
  - 1.2. Test method

This test is intended to measure the level of voltage changes, voltage fluctuations and flicker generated by ESA in configuration "REESS charging mode coupled to the power grid" through its AC power lines in order to ensure it is compatible with residential, commercial and light industrial environments.

If not otherwise stated in this annex the test shall be performed according to:

    - (a) IEC 61000-3-3 for rated current in "REESS charging mode"  $\leq 16$  A per phase and not subjected to conditional connection
    - (b) IEC 61000-3-11 for rated current in "REESS charging mode"  $> 16$  A and  $\leq 75$  A per phase and subjected to conditional connection
2. ESA state during tests
  - 2.1. The ESA shall be in configuration "REESS charging mode coupled to the power grid"

The state of charge (SOC) of the traction battery shall be kept between 20 per cent and 80 per cent of the maximum SOC during the whole time duration of the measurement (this may lead to the measurement being split into different time slots with the need to discharge the vehicle's traction battery before starting the next time slot)..

If the current consumption can be adjusted, then the current shall be set to at least 80 per cent of its nominal value.
3. Test Arrangements
  - 3.1. The tests for ESA in configuration "REESS charging mode coupled to the power grid" with rated current  $\leq 16$  A per phase and not subjected to conditional connection shall be performed according to paragraph 4. of IEC 61000-3-3.
  - 3.2. The tests for ESA in configuration "REESS charging mode coupled to the power grid" with rated current  $> 16$  A and  $\leq 75$  A per phase and subjected to conditional connection shall be performed according to paragraph 6. of IEC 61000-3-11.
  - 3.3. The test set-up for ESA in configuration "REESS charging mode coupled to the power grid" is shown in Figures 1a and 1b of the appendix to this annex.
4. Test requirements
  - 4.1. The parameters to be determined in the time-domain are "short duration flicker value", "long duration flicker value" and "voltage relative variation".

- 4.2. The limits for ESA in configuration "REESS charging mode coupled to the power grid" with input current  $\leq 16$  A per phase and not subjected to conditional connection are given in paragraph 7.12.2.1.
- 4.3. The limits for ESA in configuration "REESS charging mode coupled to the power grid" with input current  $> 16$  A and  $\leq 75$  A per phase and subjected to conditional connection are given in paragraph 7.12.2.2.

## Annex 18 – Appendix

Figure 1a  
**ESA in configuration "REESS charging mode coupled to the power grid" - Single phase test set-up**

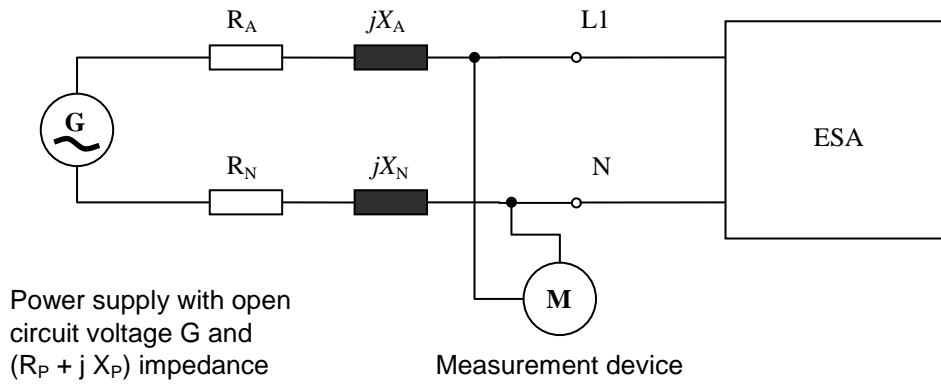
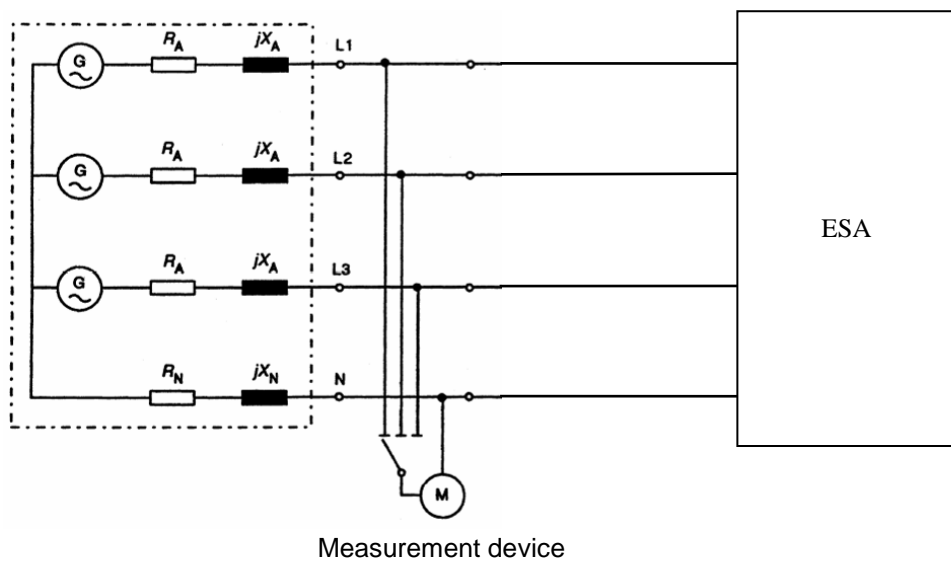

Figure 1b  
**ESA in configuration "REESS charging mode coupled to the power grid" - Three-phase test set-up**

Power supply with open circuit voltage  $G$  and  $(R_P + j X_P)$  impedance



## Annex 19

### Method(s) of testing for emission of radiofrequency conducted disturbances on AC or DC power lines from an ESA

1. General
  - 1.1. The test method described in this annex shall be applied to ESAs in configuration "REESS charging mode coupled to the power grid".
  - 1.2. Test method

This test is intended to measure the level of radio frequency conducted disturbances generated by ESA in configuration "REESS charging mode coupled to the power grid" through its AC or DC power lines in order to ensure it is compatible with residential, commercial and light industrial environments.

If not otherwise stated in this annex the test shall be performed according to CISPR 16-2-1.
2. ESA state during tests
  - 2.1. The ESA shall be in configuration "REESS charging mode coupled to the power grid".

The state of charge (SOC) of the traction battery shall be kept between 20 per cent and 80 per cent of the maximum SOC during the whole frequency range measurement (this may lead to split the measurement in different sub-bands with the need to discharge the vehicle's traction battery before starting the next sub-bands).

If the test is not performed with a REESS the ESA should be tested at rated current. If the current consumption can be adjusted, then the current shall be set to at least 80 per cent of its nominal value.
3. Test arrangements
  - 3.1. The test shall be performed according to clause 7.4.1. of CISPR 16-2-1 as table-standing equipment.
  - 3.2. The artificial mains network to be used for the measurement on vehicle components is defined in clause 4.3. of CISPR 16-1-2.

Artificial networks

The AN(s) shall be mounted directly on the ground plane. The cases of the AN(s) shall be bonded to the ground plane.

The conducted emissions on AC and DC power lines are measured successively on each power line by connecting the measuring receiver on the measuring port of the related AN, the measuring port of the AN inserted in the other power lines being terminated with a 50  $\Omega$  load.

The AN shall be placed in front, aligned and on the same side of the vehicle power charging plug.

- 3.3. The test set-up for the connection of the ESAs in configuration "REESS charging mode coupled to the power grid" is shown in Figure 1 of the appendix to this annex.
- 3.4. The measurements shall be performed with a spectrum analyser or a scanning receiver. The parameters to be used are defined in Table 1 and Table 2.

**Table 1**  
**Spectrum analyser parameters**

Frequency range MHz	Peak detector		Quasi-peak detector		Average detector	
	RBW at -3 dB	Scan time	RBW at -6 dB	Scan time	RBW at -3 dB	Scan time
0.15 to 30	9/10 kHz	10 s / MHz	9 kHz	200 s / MHz	9/10 kHz	10 s / MHz

Note:

If a spectrum analyser is used for peak measurements, the video bandwidth shall be at least three times the resolution bandwidth (RBW)

**Table 2**  
**Scanning receiver parameters**

Frequency range MHz	Peak detector			Quasi-peak detector			Average detector		
	BW at -6 dB	Step size <sup>a</sup>	Dwell time	BW at -6 dB	Step size <sup>a</sup>	Dwell time	BW at -6 dB	Step size <sup>a</sup>	Dwell time
0.15 to 30	9 kHz	5 kHz	50 ms	9 kHz	5 kHz	1 s	9 kHz	5 kHz	50 ms

<sup>a</sup> For purely broadband disturbances, the maximum frequency step size may be increased up to a value not greater than the bandwidth value.

Note:

For emissions generated by brush commutator motors without an electronic control unit, the maximum step size may be increased up to five times the bandwidth.

- 4. Test Requirements
  - 4.1 The limits apply throughout the frequency range 0.15 to 30 MHz for measurements performed in a semi anechoic chamber or an outdoor test site.
  - 4.2 Measurements shall be performed with average and either quasi-peak or peak detectors. The limits are given in Table 14 of paragraph 7.13.2.1 for AC lines and in Table 15 of paragraph 7.13.2.2. for DC lines. If peak detectors are used a correction factor of 20 dB as defined in CISPR 12 shall be applied.

## Annex 19 – Appendix

Figure 1  
**ESA in configuration "REESS charging mode coupled to the power grid"**

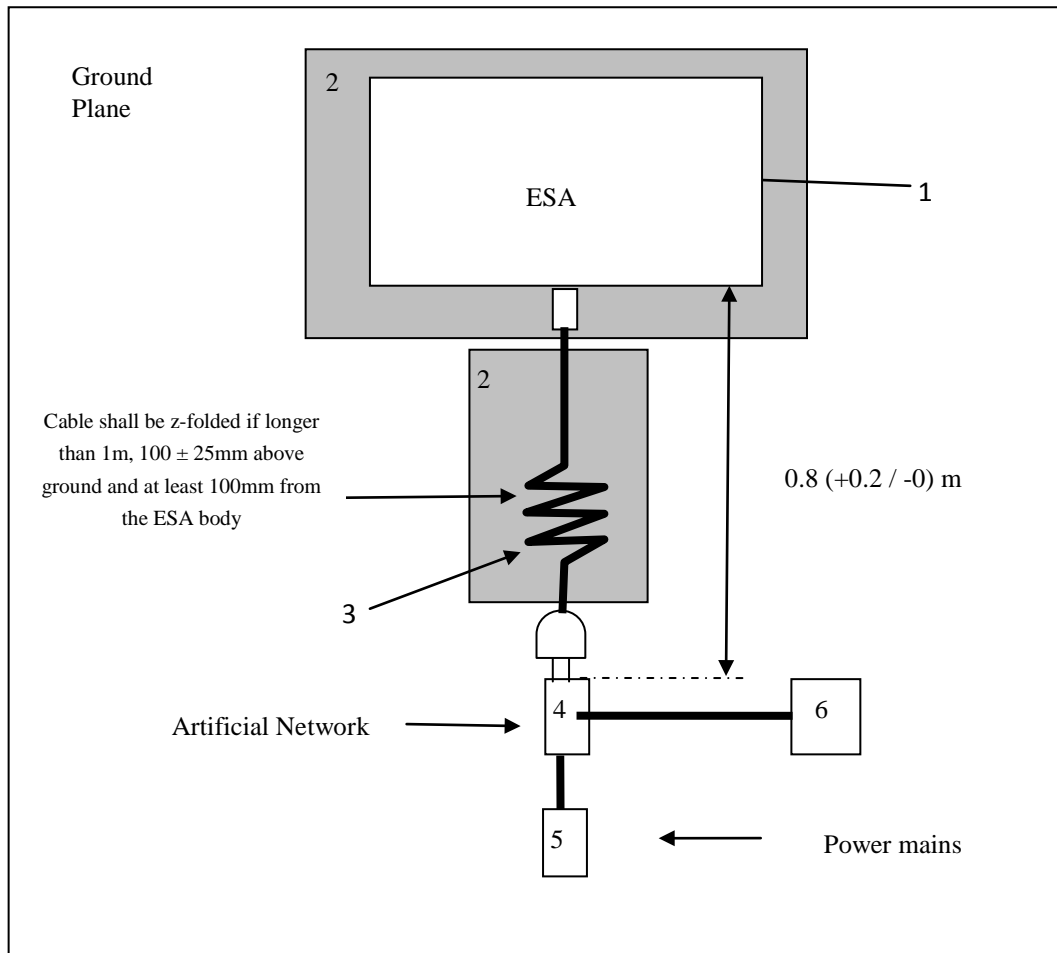

### Legend

- 1 ESA under test
- 2 Insulating support
- 3 Charging cable
- 4 AC or DC Artificial Network(s) grounded
- 5 Power mains socket
- 6 Measuring receiver

## Annex 20

### **Method(s) of testing for emission of radiofrequency conducted disturbances on network and telecommunication access from an ESA**

1. General
  - 1.1. The test method described in this annex shall be applied to ESAs in configuration "REESS charging mode coupled to the power grid".
  - 1.2. Test method

This test is intended to measure the level of radio frequency conducted disturbances generated by ESA in configuration "REESS charging mode coupled to the power grid" through its network and telecommunication access in order to ensure it is compatible with residential, commercial and light industrial environments.

If not otherwise stated in this annex the test shall be performed according to CISPR 22.
2. ESA state during tests
  - 2.1. The ESA shall be in configuration "REESS charging mode coupled to the power grid".

The state of charge (SOC) of the traction battery shall be kept between 20 per cent and 80 per cent of the maximum SOC during the whole frequency range measurement (this may lead to split the measurement in different sub-bands with the need to discharge the vehicle's traction battery before starting the next sub-bands).

If the test is not performed with a REESS the ESA should be tested at rated current. If the current consumption can be adjusted, then the current shall be set to at least 80 per cent of its nominal value.
3. Test arrangements
  - 3.1. The test set-up shall be performed according to paragraphs 8 and 9 of CISPR 22 for conducted emissions.
  - 3.2. Impedance Stabilization

Communication lines shall be applied to the ESA through IS(s).

The impedance stabilization (IS) to be connected in the network and communication cables is defined in paragraph 9.6.2. of CISPR 22.

The IS(s) shall be mounted directly on the ground plane. The case of the IS(s) shall be bonded to the ground plane.

The conducted emissions on network and telecommunication lines are measured successively on each line by connecting the measuring receiver on the measuring port of the related IS, the measuring port of the IS inserted in the other lines being terminated with a 50  $\Omega$  load.



The IS shall be placed in front, aligned and on the same side of the vehicle power charging plug.

- 3.3. The test set-up for the connection of the ESA in configuration "REESS charging mode coupled to the power grid" is shown in Figure 1 of the appendix to this annex.
- 3.4. The measurements shall be performed with a spectrum analyser or a scanning receiver. The parameters to be used are defined in Table 1 and Table 2.

Table 1  
Spectrum analyser parameters

Frequency range MHz	Peak detector		Quasi-peak detector		Average detector	
	RBW at -3 dB	Scan time	RBW at -6 dB	Scan time	RBW at -3 dB	Scan time
0.15 to 30	9/10 kHz	10 s / MHz	9 kHz	200 s / MHz	9/10 kHz	10 s / MHz

Note:

If a spectrum analyser is used for peak measurements, the video bandwidth shall be at least three times the resolution bandwidth (RBW).

Table 2  
Scanning receiver parameters

Frequency range MHz	Peak detector			Quasi-peak detector			Average detector		
	BW at -6 dB	Step size <sup>a</sup>	Dwell time	BW at -6 dB	Step size <sup>a</sup>	Dwell time	BW at -6 dB	Step size <sup>a</sup>	Dwell time
0.15 to 30	9 kHz	5 kHz	50 ms	9 kHz	5 kHz	1 s	9 kHz	5 kHz	50 ms

<sup>a</sup> For purely broadband disturbances, the maximum frequency step size may be increased up to a value not greater than the bandwidth value.

4. Test Requirements
- 4.1. The limits apply throughout the frequency range 0.15 to 30 MHz for measurements performed in a semi anechoic chamber or an outdoor test site.
- 4.2. Measurements shall be performed with average and either quasi-peak or peak detectors. The limits are given in Table 16 of paragraph 7.14.2.1. If peak detectors are used a correction factor of 20 dB as defined in CISPR 12 shall be applied.

## Annex 20 – Appendix

Figure 1  
ESA in configuration "REESS charging mode coupled to the power grid"

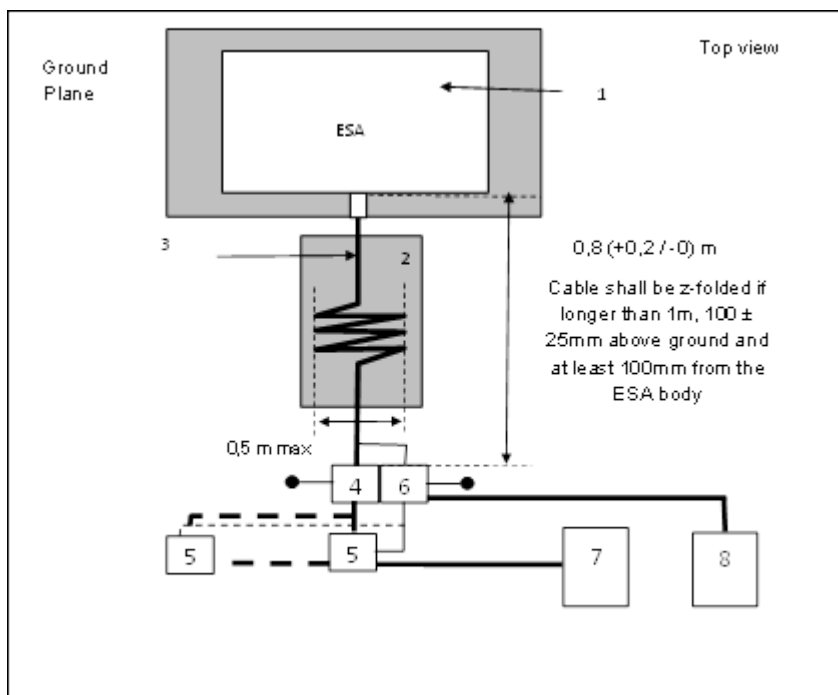

Legend

- 1 ESA under test
- 2 Insulating support
- 3 Charging / communication cable
- 4 AC or DC Artificial Network(s) grounded
- 5 Power mains socket
- 6 Impedance Stabilization(s) grounded
- 7 Charging Station
8. Measuring receiver

## Annex 21

### Method of testing for immunity of an ESA to electrical fast transient/burst disturbances conducted along AC and DC power lines

1. General
  - 1.1. The test method described in this annex shall only be applied to ESAs. This method applies only to ESA in configuration "REESS charging mode coupled to the power grid".
  - 1.2. Test method
 

This test is intended to demonstrate the immunity of the ESA. The ESA shall be subject to electrical fast transient/burst disturbances conducted along AC and DC power lines of the ESA as described in this annex. The ESA shall be monitored during the tests.

If not otherwise stated in this annex the test shall be performed according to IEC 61000-4-4.
2. ESA state during tests in configuration "REESS in charging mode coupled to the power grid"
  - 2.1. Basic ESA conditions
 

The paragraph defines minimum test conditions (as far as applicable) and failures criteria for ESA immunity tests.

<i>"REESS charging mode" ESA test conditions</i>	<i>Failure criteria</i>
<p>ESA shall be in configuration "REESS charging mode coupled to the power grid".</p> <p>The state of charge (SOC) of the traction battery shall be kept between 20 per cent and 80 per cent of the maximum SOC during the whole time duration of the measurement (this may lead to the measurement being split into different time slots with the need to discharge the vehicle's traction battery before starting the next time slot).</p> <p>If the current consumption can be adjusted, then the current shall be set to at least 20 per cent of its nominal value.</p>	<p>Incorrect charging condition (e.g. over-current, overvoltage)</p>

- 2.2. Only non-perturbing equipment shall be used while monitoring the ESA. The ESA shall be monitored to determine whether the requirements of this annex are met (e.g. by using (a) video camera(s), a microphone, etc.).
3. Test equipment
  - 3.1. The test equipment is composed of a reference ground plane (a shielded room is not required), a transient / burst generator, coupling / decoupling network (CDN) and capacitive coupling clamp.
  - 3.2. The transient/burst generator shall meet the condition defined in paragraph 6.1. of IEC 61000-4-4.

- 3.3. The coupling/decoupling network shall meet the condition defined in paragraph 6.2. of IEC 61000-4-4. When the coupling/decoupling network cannot be used on AC or DC power lines, the capacitive coupling clamp defined in paragraph 6.3. of IEC 61000-4-4 can be used.
4. Test set-up
  - 4.1. The ESA test setup is based on the laboratory type set-up as described in paragraph 7.2. of IEC 61000-4-4.
  - 4.2. The ESA shall be placed directly on the ground plane.
  - 4.3. The Technical Service shall perform the test as specified in paragraph 7.15.2.1.

Alternatively, if the manufacturer provides measurement from a test laboratory accredited to the applicable parts of ISO 17025 and recognized by the Type Approval Authority, the Technical Service may choose not to perform the test to confirm that the ESA meets the requirements of this annex.
5. Generation of required test level
  - 5.1. Test methodology
    - 5.1.1. The test method according to IEC 61000-4-4 shall be used to establish the test level requirements.
    - 5.1.2. Test phase

The ESA shall be positioned on the ground plane. The electrical fast transient/burst (EFT/B) shall be applied on the ESA on the AC/DC power lines in common modes by using CDN as described in Figure 1 of the appendix to this annex.

The test setup shall be noted in the test report.

## Annex 21 – Appendix

Figure 1  
ESA in configuration "REESS charging mode coupled to the power grid"

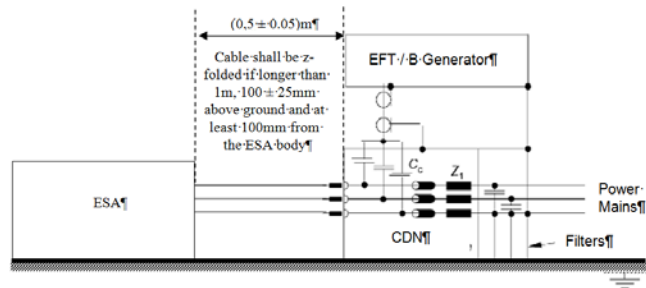

## Annex 22

### Method of testing for immunity of ESAs to surges conducted along AC and DC power lines

1. General
  - 1.1. The test method described in this annex shall only be applied to ESAs. This method applies only to ESAs in configuration "REESS charging mode coupled to the power grid".
  - 1.2. Test method
 

This test is intended to demonstrate the immunity of the ESA. The ESA shall be subject to surges conducted along AC and DC power lines of the ESA as described in this annex. The ESA shall be monitored during the tests.

If not otherwise stated in this annex the test shall be performed according to IEC 61000-4-5.
2. ESA state during tests in configuration "REESS in charging mode coupled to the power grid"
  - 2.1. The ESA shall be in charging mode.
    - 2.1.2. Basic ESA conditions
 

The paragraph defines minimum test conditions (as far as applicable) and failures criteria for ESA immunity tests.

<i>"REESS charging mode" ESA test conditions</i>	<i>Failure criteria</i>
<p>ESA shall be in configuration "REESS charging mode coupled to the power grid".</p> <p>The state of charge (SOC) of the traction battery shall be kept between 20 per cent and 80 per cent of the maximum SOC during the whole frequency range measurement (this may lead to split the measurement in different sub-bands with the need to discharge the vehicle's traction battery before starting the next sub-bands).</p> <p>If the test is not performed with a REESS the ESA should be tested at rated current. If the current consumption can be adjusted, then the current shall be set to at least 20 per cent of its nominal value.</p>	<p>Incorrect charging condition (e.g. over-current, overvoltage)</p>

- 2.2. Only non-perturbing equipment shall be used while monitoring the ESA. The ESA shall be monitored to determine whether the requirements of this annex are met (e.g. by using (a) video camera(s), a microphone, etc.).
3. Test equipment
  - 3.1. The test equipment is composed of a reference ground plane (a shielded room is not required), a surge generator and a coupling/decoupling network (CDN).
  - 3.2. The surge generator shall meet the condition defined in paragraph 6.1. of IEC 61000-4-5.
  - 3.3. The coupling/decoupling network shall meet the condition defined in paragraph 6.3. of IEC 61000-4-5.

4. Test set-up
  - 4.1. The ESA test set-up is based on the set-up described in paragraph 7.2. of IEC 61000-4-5.
  - 4.2. The ESA shall be placed directly on the ground plane.
  - 4.3. The Technical Service shall perform the test as specified in paragraph 7.16.2.1.

Alternatively, if the manufacturer provides measurement from a test laboratory accredited to the applicable parts of ISO 17025 and recognized by the Type Approval Authority, the Technical Service may choose not to perform the test to confirm that the ESA meets the requirements of this annex.
5. Generation of required test level
  - 5.1. Test methodology
    - 5.1.1. The test method according to IEC 61000-4-5 shall be used to establish the test level requirements.
    - 5.1.2. Test phase

The ESA shall be positioned on the ground plane. The electrical surge shall be applied on the ESA on the AC/DC power lines between each line and earth and between lines by using CDN as described in Figures 1 to 4 of the appendix to this annex.

The test set-up shall be noted in the test report



Annex 22 – Appendix

ESA in configuration "REESS charging mode coupled to the power grid"

"Figure 2  
ESA in configuration "REESS charging mode coupled to the power grid" - Coupling between lines for DC or AC (single phase) power lines.

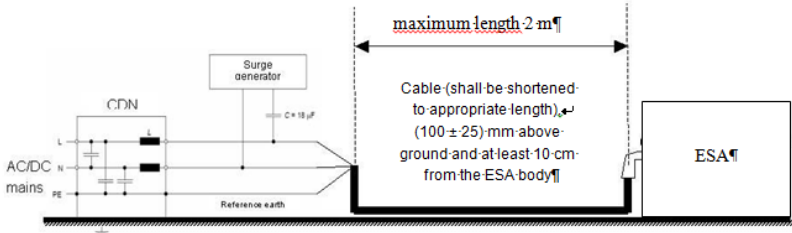
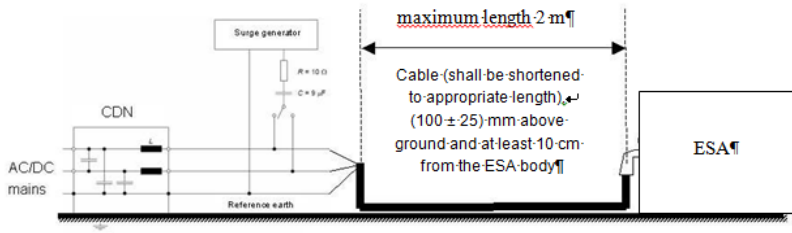
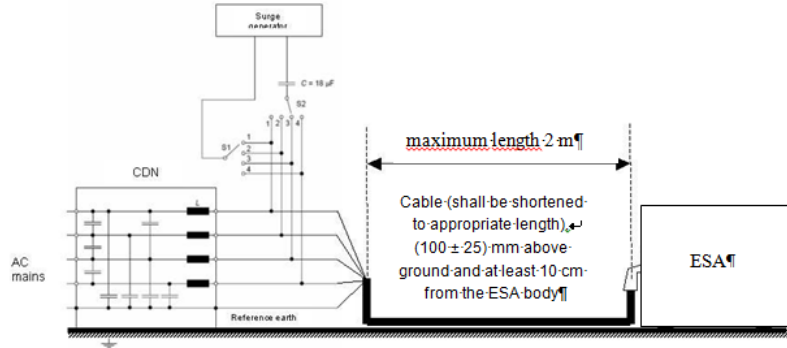

Figure 3  
ESA in configuration "REESS charging mode coupled to the power grid" - Coupling between each line and earth for DC or AC (single phase) power lines



**Figure 4**  
**ESA in configuration "REESS charging mode coupled to the power grid" - Coupling between lines for AC (three phases) power lines**



**Figure 5**  
**ESA in configuration "REESS charging mode coupled to the power grid" - Coupling between each line and earth for AC (three phases) power lines**

