

**Informal Dummy Working Group
WorldSID Meetng
26 October 2011, Seoul, Korea**

**WorldSID 50th
Data Acquisition System
Open Source Specification
DAS-Mass**

Bruce Donnelly

Dan Rhule

NHTSA

Jim Stricklin

TRC

Jack Jensen

Ken Wiley

ISO WSID Group

Klaus Bortenschlager

Philipp Wernicke

PDB



WorldSID 50th DAS-Mass: Objective

Objective:

- **To develop an open source specification for an onboard data acquisition system for the WorldSID 50th dummy suitable for inclusion into CFR 49, part 572**

Requirements:

- **No structural or design changes to the dummy**
- **No change in response (within tolerance TBD)**
- **No DAS interference with existing dummy parts**
- **Cables are considered system neutral (mass negligible)**



WorldSID 50th DAS-Mass: Task Plan

Task Plan

- Develop gray spaces ✓
- Measure mass properties ✓
- Define existing data acquisition mass ✓
- Select a standard test to model ✓
- Develop the parameter variation plan for modeling ✓
- Model the baseline test
- Model the parameter matrix
- Calculate the variation in response (average coefficient of variation) for the run matrix
- Develop the specification for onboard data acquisition allowable mass properties



WorldSID 50th DAS-Mass: “Gray” Spaces

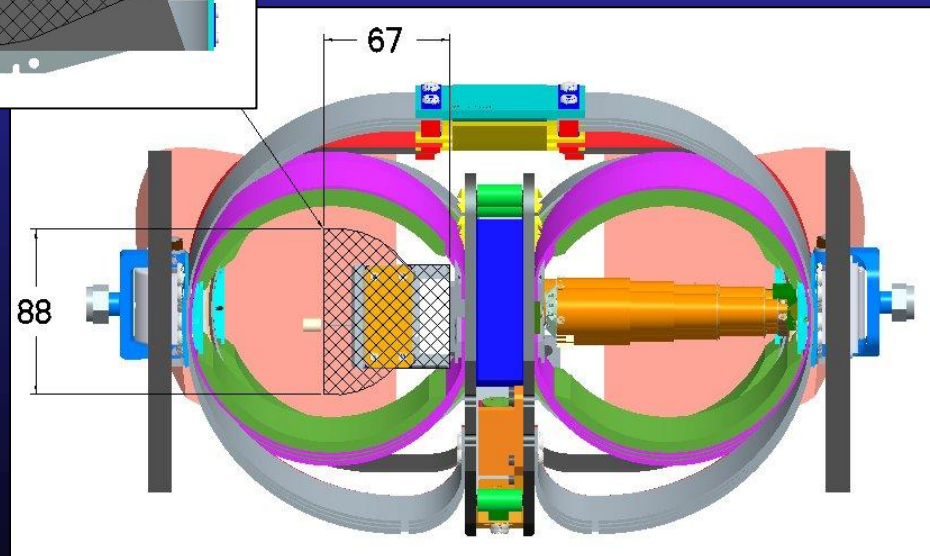
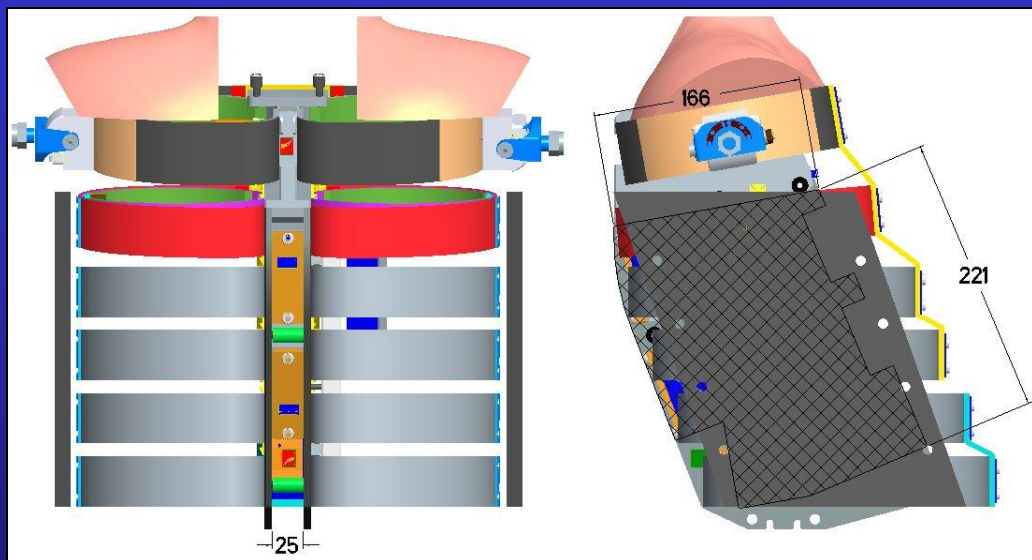

WorldSID 50th DAS-Mass : “Gray” Spaces

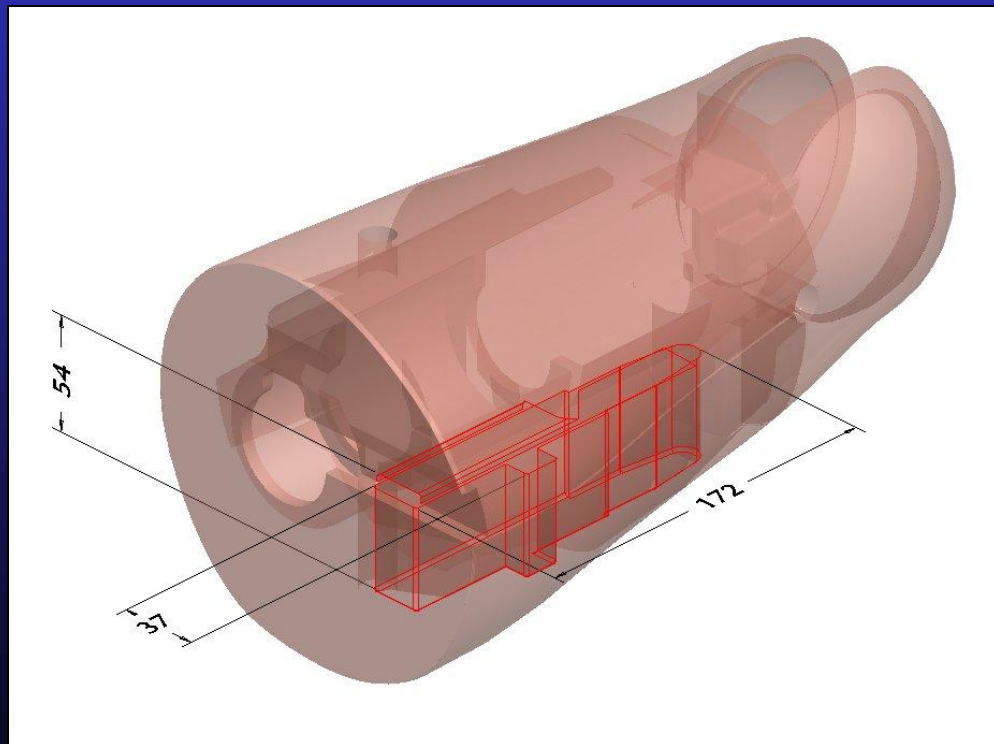
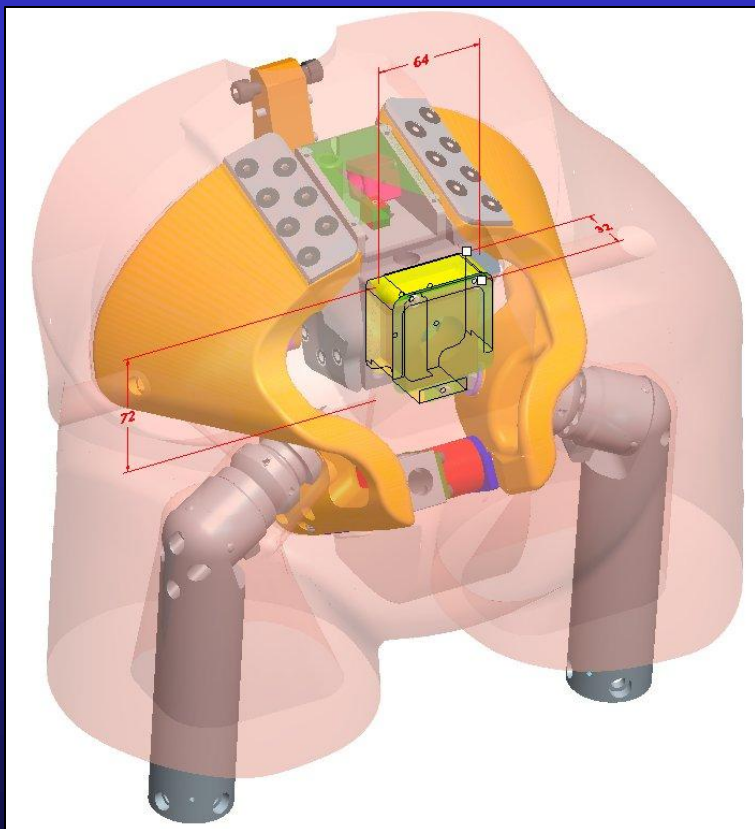

WorldSID 50th DAS-Mass: Mass Properties

WORLDSID SEGMENT WEIGHTS, PRINCIPAL MOMENTS OF INERTIA AND CENTERS OF GRAVITY

Prepared for
U.S DEPARTMENT OF TRANSPORTATION (DOT)

NATIONAL HIGHWAY TRAFFIC SAFETY ADMINISTRATION (NHTSA)
VEHICLE RESEARCH AND TEST CENTER (VRTC)
EAST LIBERTY, OH

June 2011

Provided by
Infoscitex Corp.

Wright-Patterson Air Force Base, Ohio



WorldSID 50th DAS-Mass: DAS Mass

Part Number	Description	Location	Quantity	Mass (Each)	Total Mass	Part Purpose
W50-31042	Mounting Bracket #1	Inside Spine Box	2		0.000	Required to install a G5 or G5 mass replacement but is not a structural component???
W50-31043	Mounting Bracket #2	Inside Spine Box	2		0.000	Required to install a G5 or G5 mass replacement but is not a structural component???
W50-75001	Interposer Replacement	Inside Spine Box	2	0.128	0.256	Non-structural mass replacement
W50-75002	Connector Housing Replacement	Inside Spine Box	2	0.034	0.068	Non-structural mass replacement
W50-31045	Cover Plate Spine Box	Inside Spine Box	2	0.080	0.160	Required to contain a G5 or G5 mass replacement but is not a structural component
W50-37022	Backup Plate Mounting Bracket	Inside Spine Box	2		0.000	Required to install a G5 connector housing or connector housing structural replacement but is not a structural component
W50-74307	G5 Mass replacement	Inside Spine Box	3	0.188	0.564	Non-structural mass replacement
W50-37015	G5 Mount	Non-Struck Side of Spine Box	1	0.358	0.358	Required to contain a G5 or G5 mass replacement but is not a structural component
W50-74307	G5 Mass replacement	Non-Struck Side of Spine Box	1	0.188	0.188	Non-structural mass replacement
W5-3325	Battery Replacement	Pelvis	1		0.000	Non-structural mass replacement
W50-43001	Battery Container, WSID	Pelvis	1		0.000	This part is intended to house the battery for the G5 DAS system. It is a structural component in that it allows the pelvis assembly to rest on the pelvis flesh
W50-43002	Battery Cover, WSID	Pelvis	1		0.000	This part is intended to house the battery for the G5 DAS system. It is a structural component in that it allows the pelvis assembly to rest on the pelvis flesh
W50-75002	Connector Housing Replacement	Pelvis	1	0.034	0.034	This part is a carry-over from when the G5 docking station was installed in the pelvis. It is not a structural component and is there to maintain original design mass.
W50-51052	G5 DAS Leg Docking Station Mass Replacement	Upper Leg	1	0.070	0.070	Non-structural mass replacement
W50-74307	G5 Mass replacement	Upper Leg	1	0.188	0.188	Non-structural mass replacement



WorldSID 50th DAS-Mass: Sled Test

Channels

Thorax rib displacement
Abdomen rib displacements
T1 Y acceleration
T12 Y acceleration
Pelvis Y acceleration
Pubic symphysis force

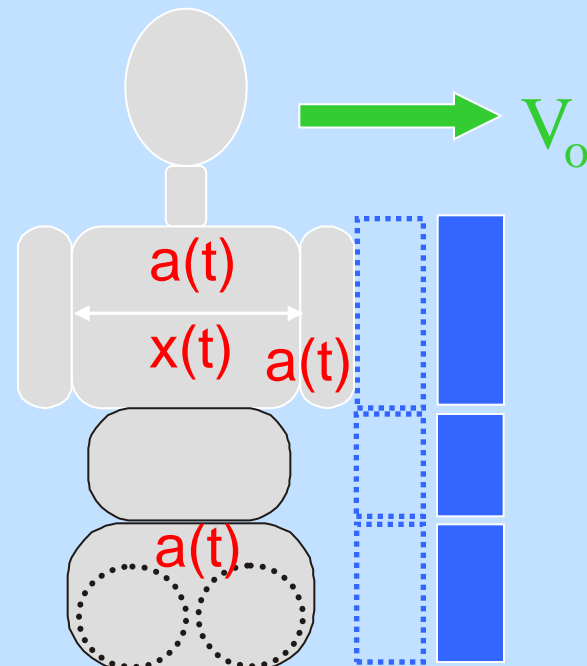

WorldSID 50th DAS-Mass: Cumulative C.V.

Time based analysis

(J. Shaw, Stapp 2006)

Average C.V. across time

Upper 50% only

C. V. = 0.05 allowable

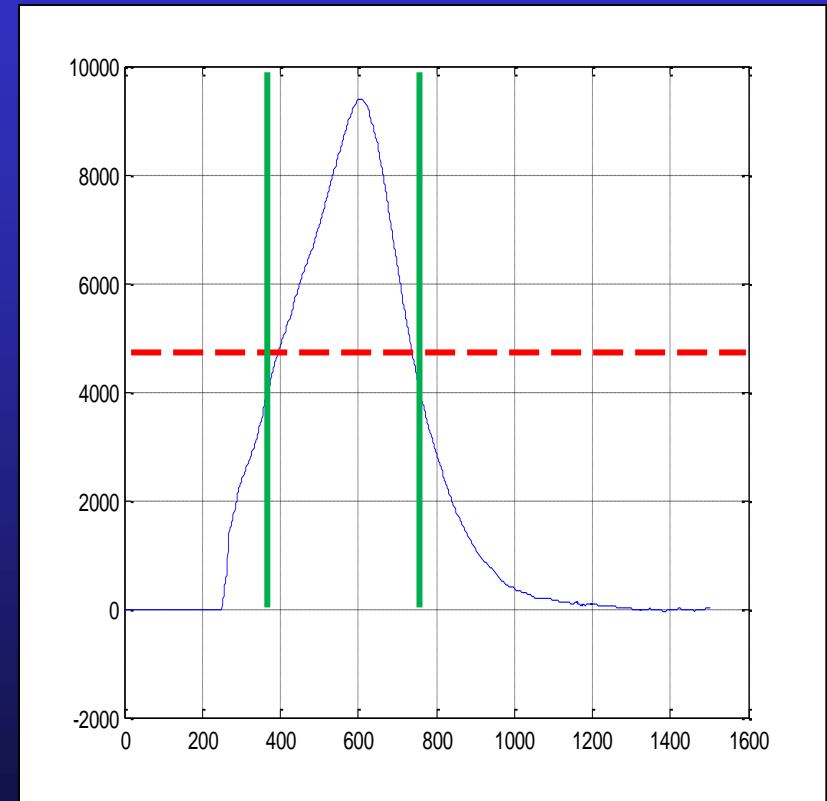

WorldSID 50th DAS-Mass: To Do

- Model the baseline test
 - P. Wernicke/PDB
- Model the parameter matrix
 - P. Wernicke/PDB
- Calculate the variation in response
 - B. Donnelly/P. Wernicke
- Develop the specification
 - J. Jensen, K. Wiley, B. Donnelly, D. Rhule, P. Wernicke

