

Transmitted by the chairman of the informal group on Child Restraint Systems

Informal document **GRSP-52-20**
(52nd GRSP, 11 – 14 December 2012,
agenda item 21)

Informal document **WP.29-158-22**
(158th WP.29, 13-16 November 2012,
~~agenda item 4.13.3)GRSP xxxx~~

Formatted: Heading 3, Indent: Left: 0 cm

Formatted: Heading 3

Proposal for corrections to ECE/TRANS/WP.29/2012/53 (GRSP) Proposal for a new Regulation on Child Restraints Systems

The text reproduced below was drafted by the chairman of the IWG CRS

The first modifications proposed by the IWG CRS and presented to WP29 during the 158th WP.29, 13-16 November 2012, agenda item 4.13.3 as Informal document WP.29-158-22 are marked in purple or strikethrough characters.

A second set of modifications (in red) will be proposed by the chairman of the IWG CRS during 52nd meeting of GRSP

Formatted: Normal, Indent: Left: 3 cm, First line: 0 cm, Tab stops: Not at 14.99 cm

Formatted: Superscript

Figure of paragraph 4.5., replace by the following figure:

“Minimum label size 40 x 40 mm

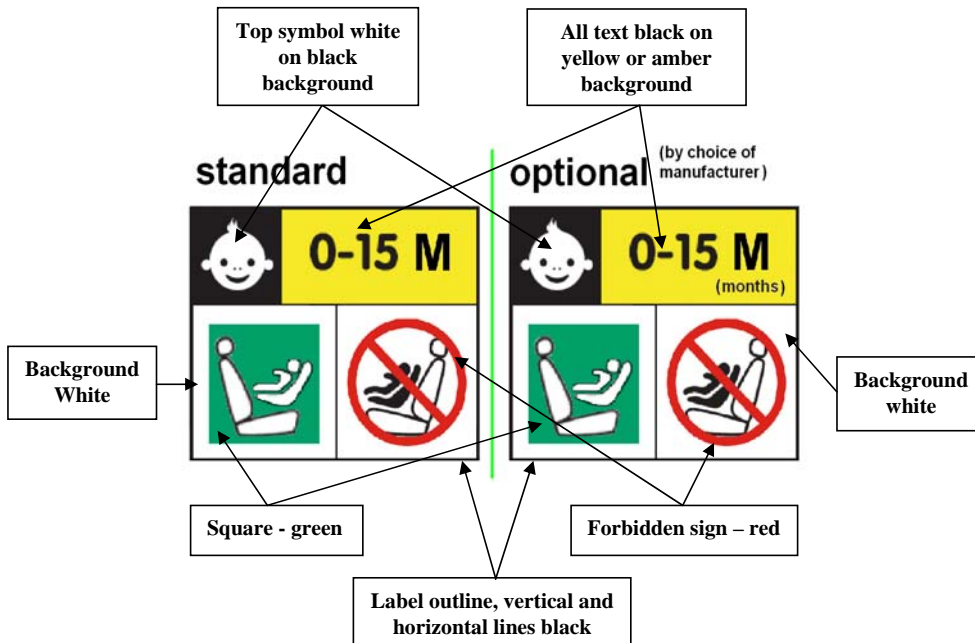

Paragraph 6.3.1.1., amend to read

6.3.1.1. The Child Restraint System manufacturer shall declare in writing that the toxicity of materials used in the manufacture of restraint systems and accessible to the restrained child is in conformity with the relevant parts of EN 71-3:1994/A1:2000/AC. Tests confirming the validity of the declaration may be carried out at the discretion of the test authority.

Paragraph 6.3.1.2., amend to read

6.3.1.2. The Child Restraint System manufacturer shall declare in writing that the flammability of materials used to manufacture the restraint system is in conformity with the relevant paragraphs of EN 71-2:2011. Tests confirming the validity of the declaration may be carried out at the discretion of the test authority.

Paragraph 6.3.5., amend to read:

6.3.5. i-Size Child Restraint System support-leg and support-leg foot requirements
i-Size Child restraint systems fitted with support-legs must comply in all positions of use (e.g. in case of length adjustable attachment, base, etc. the

shortest and longest position) with the geometrical provisions defined in 6.3.5. and its subparagraphs.

Compliance with the requirements specified in paragraphs 6.3.5.1. and 6.3.5.2. may be verified by a physical or computer simulation.

The geometrical requirements in paragraphs 6.3.5.1. to 6.3.5.4. are referenced to a coordinate system, whose origin is located centrally between the two ISOFIX attachments and on the centreline of the corresponding ISOFIX anchorage system.

The orientation of the axes of the coordinate system is referenced to the child restraint fixture(s):

- (a) The X'_z axis shall be parallel to the Child Restraint Fixture (CRF)¹ bottom surface and in ~~to~~ the median longitudinal plane of the CRF;
- (b) The Y'_z axis shall be perpendicular to the median longitudinal plane;
- (c) The Z'_z axis shall be perpendicular to the CRF bottom surface.

In fulfilling the requirements of this section, the Child Restraint System shall be installed in accordance with the user manual of the Child Restraint System. The storage position of the support-leg is excluded from these requirements."

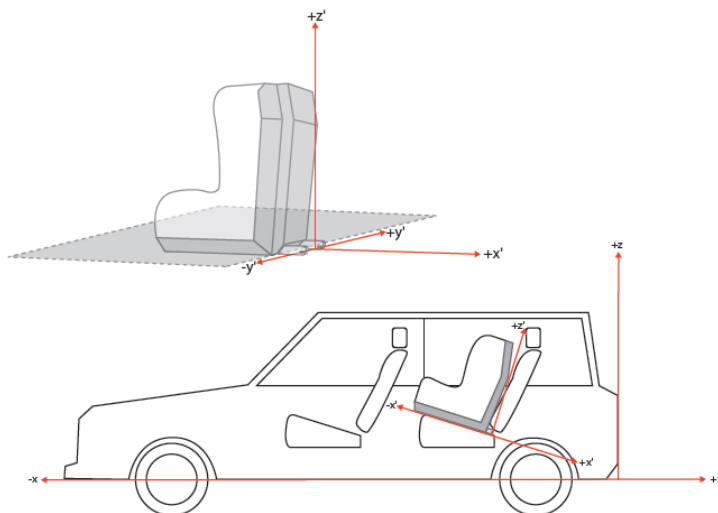

6.3.5.1. Support-leg and support-leg foot geometrical requirements

The support leg, including its attachment to the child restraint systems and the support-leg foot shall lie completely within the support leg dimension assessment volume (see also figures 1 and 2 of annex 19 of this Regulation), which is defined as follows:

¹ Child Restraint Fixture (CRF) as defined in Regulation No. 16 (Safety-belts).

- (a) In width by two planes parallel to the $X'_1 - Z'_1$ plane separated by 200 mm, and centered around the origin; and
- (b) In length by two planes parallel to the $Z'_1 - Y'_1$ plane and positioned at distances of 585 mm and 695 mm forward of the origin along the X'_1 axis; and
- (c) In height by a plane parallel to the $X'_1 - Y'_1$ plane, positioned at a distance of 70 mm above the origin and measured perpendicular to the $X'_1 - Y'_1$ plane. Rigid, non-adjustable parts of the support-leg shall not extend beyond a plane parallel to the $X'_1 - Y'_1$ plane, positioned at a distance of 285 mm below the origin and perpendicular to the $X'_1 - Y'_1$ plane. ~~For parts adjustable in the Z direction there shall be no limitation in height below the level of the CRF bottom surface, providing it is also possible to adjust them to meet the requirements of the support leg dimension assessment volume.~~

6.3.5.2. Support-leg foot adjustability requirements

The support-leg shall be adjustable in order to ensure that the support-leg foot can be positioned throughout the height range of the support-leg foot assessment volume as specified below (see also figures 3 and 4 of Annex 19 of this Regulation). Where incremental adjustment is provided, the step between two locked positions shall not exceed 20 mm.

The support leg foot assessment volume is defined as follows:

- (a) In width by two planes parallel to the $X'_1 - Z'_1$ plane, separated by 200 mm, and centered around the origin; and
- (b) In length by two planes parallel to the $Z'_1 - Y'_1$ plane and positioned at distances of 585 mm and 695 mm forward of the origin along the X'_1 axis; and
- (c) In height by two planes parallel to the $X'_1 - Y'_1$ plane positioned at distances of 285 mm and 540 mm below the origin along the X'_1 axis.

It shall be permissible for the support-leg to be adjustable beyond the height limits in the Z'_1 direction (as indicated by key #6 in Figure 3 of Annex 19), providing that no parts extend beyond the limiting planes in the X'_1 and Y'_1 directions.

6.3.5.3. Support-leg foot dimensions

The dimensions of the support-leg foot shall meet the following requirements:

- (a) Minimum support-leg contact surface shall be 2500 mm², measured as a projected surface 10 mm above the lower edge of the support-leg foot (see figure 0(d));
- (b) Minimum outside dimensions shall be 30 mm in the X'_1 and Y'_1 directions, with maximum dimensions being limited by the support-leg foot assessment volume;
- (c) Minimum radius of the edges of the support-leg foot shall be 3.2 mm.

Paragraph 7.1.3.5.2.1., amend to read:

"7.1.3.5.2.1. Installation of a Child Restraint System on the test bench.

The unoccupied ISOFIX Child Restraint System shall be attached to the ISOFIX anchorage system.

Securing the ISOFIX attachments to the ISOFIX lower anchorages shall be permitted to draw the unoccupied child restraint system towards those anchorages.

An additional force of 135 +/-15N shall be applied in a plane parallel to the surface of the test seat cushion. The force shall be applied along the centre line of the Child Restraint System and at a height no more than 100mm above the cushion.

If present, the top tether shall be adjusted to achieve a tension load of 50 +/- 5N. Alternatively, and if present, the support-leg shall be adjusted according to the child restraint system manufacturer's instructions.

The Child Restraint System centre line shall be aligned with the centre line of the test bench.

The dummy shall be placed in the Child Restraint System separate from the seat-back of the chair by a flexible spacer. The spacer shall be 2.5 cm thick and 6 cm wide. It shall have length equal to the shoulder height less the thigh height, both in the sitting position and relevant to the dummy size being tested. The resulting ~~length~~ height of the spacer is listed in the table below for the different dummy sizes. The board should follow as closely as possible the curvature of the chair and its lower end should be at the height of the dummy's hip joint."

Annex 17, paragraphs 1.2. and 1.3., amend to read :

“1.2. If that is not the case, a calculation of the value of HPC is made, on the basis of the acceleration (a)², by the following expression:

$$\text{HPC} = (t_2 - t_1) \left[\frac{1}{t_2 - t_1} \int_{t_1}^{t_2} a dt \right]^{2.5}$$

in which:

- 1.2.1. the term "a" is the resultant acceleration [±]is measured in units of gravity, g (1 g = 9,81 m/s²);
- 1.2.2. if the beginning of the head contact can be determined satisfactorily, t₁ and t₂ are the two time instants, expressed in seconds, defining an interval between the beginning of the head contact and the end of the recording for which the value of HPC is maximum;
- 1.2.3. if the beginning of the head contact cannot be determined, t₁ and t₂ are the two time instants, expressed in seconds, defining a time interval between the beginning and the end of the recording for which the value of HPC is maximum;
- 1.2.4. values of HPC for which the time interval (t₁ - t₂) is greater than 36 ms are ignored for the purposes of calculating the maximum value.
- 1.3. The value of the resultant head acceleration during forward impact which is exceeded for 3 ms cumulatively is calculated from the resultant head acceleration³.”

² The acceleration (a) referring to the centre of gravity is calculated from the triaxial components of the acceleration measured with a CFC of 1000.

³ ~~The acceleration (a) referring to the centre of gravity is calculated from the triaxial components of the acceleration measured with a CFC of 1000.~~

Annex 19, figure 1 to figure 3., amend to read :

" Assessment volumes for i-size support-legs and support-leg feet

Figure 1
Side view of the support leg dimension assessment volume

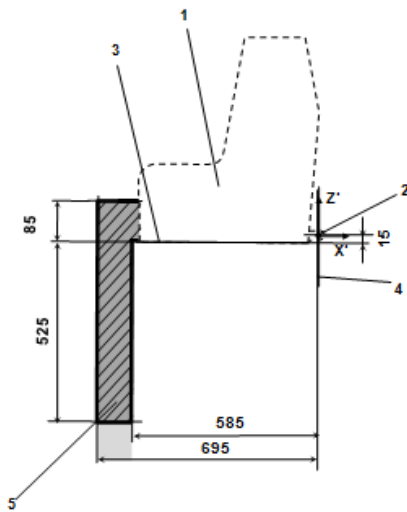

Key:

1. Child Restraint Fixture (CRF)
2. ISOFIX low anchorages bar
3. Plane formed by the bottom surface of the CRF, which is parallel to and 15 mm below the X'_1 - Y'_1 plane of the coordinate system
4. Z'_1 - Y'_1 plane of the coordinate system
5. Upper part of the support-leg dimension assessment volume, which shows the dimensional limitations in X'_1 and Y'_1 direction, the upper height limit in Z'_1 direction, as well as the lower height limitation in Z'_1 direction for rigid, not in Z'_1 direction adjustable support leg components

Notes:

1. Drawing not to scale.
2. Volumes (5 and 6) are defining the maximum limits of the support leg and its foot. No parts of the CRS shall exceed these limits in any position of adjustment when in use configuration.

Figure 2
3D view of the support leg dimension assessment volume

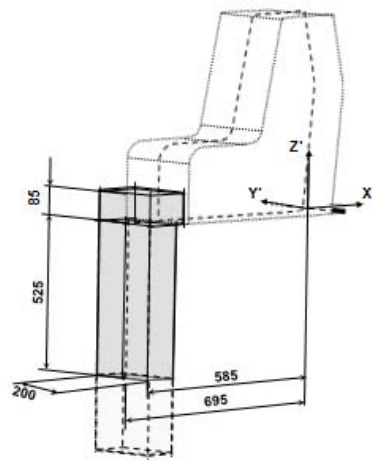

Notes:

1. Drawing not to scale.

Figure 3
Side view of the support leg foot assessment volume

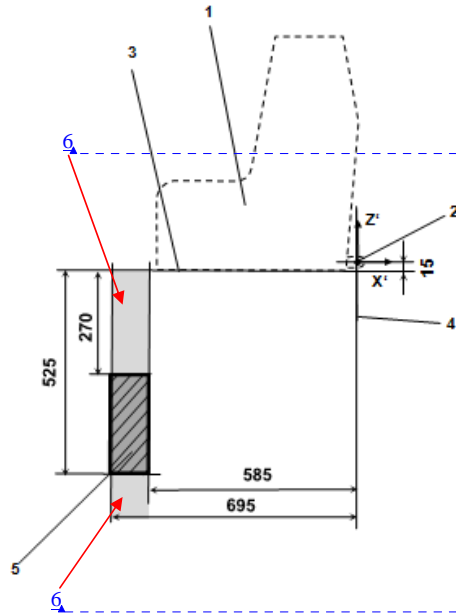

Formatted: French (France)

Formatted: French (France)

Key:

1. Child Restraint Fixture (CRF)
2. ISOFIX low anchorages bar
3. Plane formed by the bottom surface of the CRF, which is parallel to and 15 mm below the X-Y plane of the coordinate system
4. Z-Y plane of the coordinate system
5. Support-leg foot assessment volume, which shows the required adjustment range of the support-leg foot in Z directions, as well as the dimensional limitations in X and Y direction
6. Additional volumes shows the additional permissible adjustment range in Z direction for the support-leg foot

Formatted: Not Highlight

Notes:

1. Drawing not to scale"