



Economic and Social Council

Distr.: General
6 February 2012

Original: English

Economic Commission for Europe

Inland Transport Committee

World Forum for Harmonization of Vehicle Regulations

Working Party on General Safety Provisions

102nd session

Geneva, 16–20 April 2012

Item 11 of the provisional agenda

Regulation No. 125 (Forward field of vision of drivers)

Proposal for amendments to Regulation No. 125

Submitted by the expert from Japan *

The text reproduced below was prepared by the expert from Japan on the driver's perception of other road users. It is mainly based on ECE/TRANS/WP.29/GRSG/2011/31. The modifications to the current text of the Regulation are marked in bold for new or strikethrough for deleted characters.

*In accordance with the programme of work of the Inland Transport Committee for 2010–2014 (ECE/TRANS/208, para. 106 and ECE/TRANS/2010/8, programme activity 02.4), the World Forum will develop, harmonize and update UN Regulations in order to enhance the performance of vehicles. The present document is submitted in conformity with that mandate.

I. Proposal

The table of contents, amend to read:

"Regulation

1. Scope

...

11. Names and addresses of Technical Services responsible for conducting approval tests, and of Administrative Departments

12. Transitional Provisions"

Paragraph 4.2., amend to read:

"4.2. An approval number shall be assigned to each type approved. Its first two digits (~~00~~ **at present 01** for the Regulation in its ~~initial~~ **current** form) shall indicate the series of amendments incorporating the most recent major technical amendments made to the Regulation at the time of issue of the approval. The same Contracting Party shall not assign the same number to the same vehicle type equipped with another type of field of vision, or to another vehicle type. "

Insert a new paragraph 5.1.4., including new figures 1 and 2, to read:

"5.1.4. In the case where the height of V2 above the ground exceeds 1,650 mm, the following requirement shall be met:

A 1,200 mm tall cylindrical object with a diameter of 300 mm that is situated inside the space bounded by a vertical plane located 2,000 mm in front of the vehicle, a vertical plane located 2,300 mm in front of the vehicle, a vertical plane located 400 mm from the driver's side of the vehicle, and a vertical plane located 600 mm from the opposite side of the vehicle shall be at least partially visible when viewed directly from V2 (see figure 1), regardless of where the object is within that space, unless it is invisible due to a blind spot(s) created by the A pillars, windscreen wipers, or steering wheel.

If the driver's seat is located in the central driving position of the vehicle, the 1,200 mm tall cylindrical object shall be situated inside the space bounded by a vertical plane located 2,000 mm in front of the vehicle, a vertical plane located 2,300 mm in front of the vehicle, a vertical plane located 500 mm from the side of the vehicle (see figure 2).

Figure 1

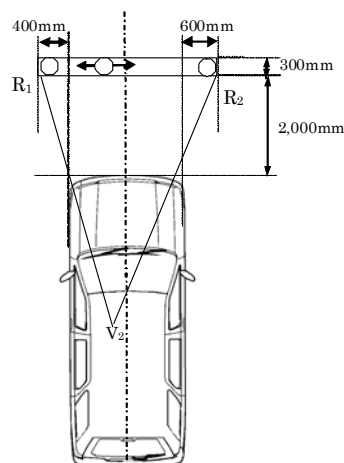
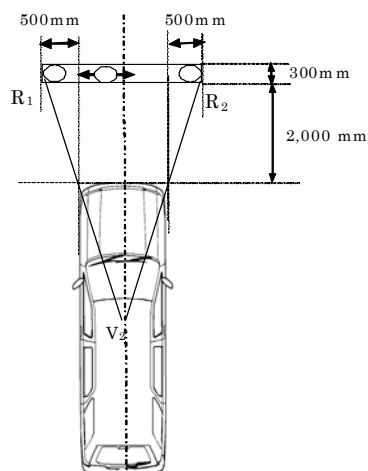

Figure 2



Insert new paragraphs 12.1. to 12.8., to read:

"12. Transitional Provisions

- 12.1. As from the official date of entry into force of the 01 series of amendments, no Contracting Party applying this Regulation shall refuse to grant approval under this Regulation as amended by the 01 series of amendments.
- 12.2. As from [24] months after the date of entry into force, Contracting Parties applying this Regulation shall grant approvals only if the vehicle type to be approved meets the requirements of this Regulation as amended by the 01 series of amendments.
- 12.3. Contracting Parties applying this Regulation shall not refuse to grant extensions of approval to the preceding series of amendments to this Regulation.
- 12.4. Contracting Parties applying this Regulation shall continue to grant approvals to those types of vehicles which comply with the requirements of this Regulation as amended by the preceding series of amendments during the [24] months' period which follows the date of entry into force of the 01 series of amendments.
- 12.5. No Contracting Party applying this Regulation shall refuse national or regional type approval of a vehicle type approved to the 01 series of amendments to this Regulation.
- 12.6. Until [72] months after the date of entry into force of the 01 series of amendments to this Regulation, no Contracting Party applying this Regulation shall refuse national or regional type approval of a vehicle type approved to the preceding series of amendments to this Regulation.
- 12.7. Starting [72] months after the entry into force of the 01 series of amendments to this Regulation, Contracting Parties applying this Regulation may refuse (national or regional type approval and may

refuse) first national or regional registration (first entry into service) of a vehicle which does not meet the requirements of the 01 series of amendments to this Regulation.

- 12.8. Notwithstanding the transitional provisions above, Contracting Parties whose application of this Regulation comes into force after the date of entry into force of the most recent series of amendments are not obliged to accept approvals which were granted in accordance with any of the preceding series of amendments to this Regulation."

Annex 2, amend to read:

"Annex 2

Arrangements of approval marks

See paragraphs 4.4. to 4.4.2. of this Regulation

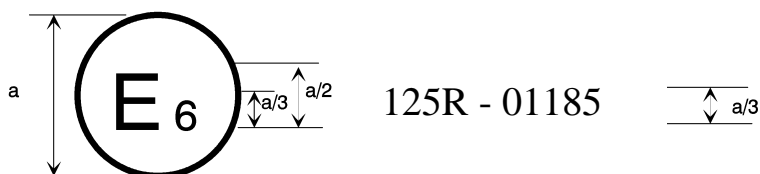

a = 8 mm min

The above approval mark affixed to a vehicle shows that the vehicle type concerned has been approved in Belgium (E6) with regard to the driver's forward field of vision pursuant to Regulation No. 125. The first two digits of the approval number indicate that the approval was granted in accordance with the requirements of Regulation No. 125 ~~in its original form~~ **as amended by the 01 series of amendments.**"

II. Justification

1. This proposal for the 01 series of amendments adds the transitional provisions and amends the arrangements of approval marks.
2. This proposal is a modified version of ECE/TRANS/WP.29/GRSG/2011/31, which was submitted for the purpose of preventing road accidents due to the inability of drivers of vehicles with an extremely high eye point to view small vehicles (e.g. motorcycles) in front.
3. In this proposal, the extremely high eye point is specifically described. Since, in general, vehicles where the eye point height is no more than 1,650 mm are presumed to satisfy the requirement of paragraph 5.1.4., Japan proposes to limit the scope of the requirement to those vehicles where the eye point height exceeds 1,650 mm.