

**Economic and Social Council**

Distr.: General
22 September 2011

Original: English
English and French

Economic Commission for Europe**Inland Transport Committee****World Forum for Harmonization of Vehicle Regulations****Working Party on Passive Safety****Fiftieth session**

Geneva, 6–9 December 2011

Item 10 of the provisional agenda

Regulation No. 16 (Safety-belts)**Proposal for Supplement 3 to the 06 series of amendments****Submitted by the Chair of the informal group on Child Restraint Systems ***

The text reproduced below was prepared by the informal group on Child Restraints Systems (CRS), following discussions at its twenty-seventh meeting introducing requirements for "i-Size" CRS according to the draft new CRS Regulation (ECE/TRANS/WP.29/GRSP/2011/21). It is based on a document without symbol (GRSP-49-07) distributed during the forty-ninth session of GRSP (see ECE/TRANS/GRSP/49, para. 21). The modifications to the text of the Regulation are bold for new or strikethrough for deleted characters.

* In accordance with the programme of work of the Inland Transport Committee for 2010–2014 (ECE/TRANS/2010/8, programme activity 02.4), the World Forum will develop, harmonize and update Regulations in order to enhance the performance of vehicles. The present document is submitted in conformity with that mandate.

I. Proposal

The title of the Regulation, amend to read:

- "I. ...
- II Vehicles equipped with safety-belts, safety-belt reminder, restraint systems, child restraint systems ~~and~~, ISOFIX child restraint systems **and i-Size child restraint systems.**"

The table of contents,

Insert the reference to a new Table 3 to Appendix 3 of Annex 17, to read:

"Annex 17 - ...

Appendix 3 - Table 1 - ...

...

Table 3 - Table of vehicle handbook information on i-Size child restraint systems for installation in various seating positions"

The text of the Regulation,

Insert a new paragraph 1.7., to read:

- "1.7. At the request of the manufacturer, it also applies to installing i-Size child restraint systems, in case i-Size seating positions are defined by the vehicle manufacturer."**

Paragraph 2.10., amend to read:

- "2.10. **"Child restraint"** means a safety device as defined in Regulation No. 44 **or Regulation No. [XXX]."**

Paragraph 2.31., amend to read:

- "2.31. **"ISOFIX position** means a system ...

...

(e) ...

(f) **or an i-Size child restraint system as defined in Regulation No. [XXX],**

(g) **or a specific vehicle ISOFIX child restraint system as defined in Regulation No. [XXX]."**

Paragraph 2.34., amend to read:

- "2.34. **"Anti-rotation device"**

...

(b) ...

(c) **An anti-rotation device for an i-Size child restraint system consists of either a top tether or a support leg, which is intended to limit the rotation of the restraint during a frontal impact.**

(d) For ISOFIX, i-Size, universal and semi-universal, child restraint systems the vehicle seat itself does not constitute an anti-rotation device."

Paragraph 2.38., amend to read:

"2.38. **"Child restraint fixture"** (CRF) means a fixture according to one out of the ~~seven~~**eight** ISOFIX size classes defined in ..."

Insert a new paragraph 2.39., to read:

"2.39. **"i-Size support leg installation assessment volume"** means a volume, which ensures the dimensional and geometrical compatibility between the support leg of an i-Size child restraint system and an i-Size seating position of a vehicle."

Insert a new paragraph 2.40., to read:

"2.40. **"i-Size seating position"** means a seating position, if defined by the vehicle manufacturer, which is designed to accommodate an i-Size child restraint system, as defined in Regulation No. [XXX], and fulfils the requirements defined in this Regulation."

Paragraphs 2.39.to 2.45.(former), renumber as paragraphs 2.41. to 2.47.

Paragraph 5.2.4.1.,footnote ⁴, amend to read:

⁴ **The distinguish numbers of the Contracting Parties to the 1958 Agreement are reproduced in Annex 3 to Consolidated Resolution on the Construction of Vehicles (R.E.3), document TRANS/WP.29/78/Rev.2."**

Paragraph 8.2.1., amend to read:

"8.2.1. Safety-belts, restraint systems, ~~and~~ ISOFIX child restraint systems according to table 2 of Annex 17 – Appendix 3, **as well as i-Size child restraint systems according to table 3 of Annex 17 – Appendix 3**, shall be fixed to anchorages **and in case of i-Size child restraint systems, supported by a vehicle floor contact surface**, conforming to the specifications of Regulation No. 14, such as the design and dimensional characteristics, the number of anchorages, and the strength requirements."

Paragraph 8.2.2., amend to read:

"8.2.2. The safety-belts, restraint systems; **and** child restraint systems ~~and ISOFIX child restraint systems~~ recommended by the manufacturer according to tables 1 ~~and 2~~ **to 3** of Annex 17 – Appendix 3, shall be so installed that they will work satisfactorily and reduce the risk of bodily injury in the event of an accident. In particular they shall be so installed that:"

Paragraph 8.2.2.3., amend to read:

"8.2.2.3. The risk of the strap deteriorating through contact with sharp parts of the vehicle or seat structure, **and** child restraint systems ~~and ISOFIX child restraint systems~~ recommended by the manufacturer according to tables 1 ~~and 2~~ **to 3** of Annex 17 – Appendix 3, is reduced to a minimum."

Insert a new paragraph 8.3.6., to read:

"8.3.6. **Any i-Size seating position shall allow the installation of the ISOFIX child restraint fixtures "ISO/F2X" (B1), "ISO/R2" (D) and the support leg installation assessment volume as defined in Appendix 2 of Annex 17.**

The support leg installation assessment volume is characterized as follows (see also Annex 17, Appendix 2, figures 8 and 9 of this Regulation):

(a) **Lateral limitation:**

By two planes parallel to and 100 mm apart from the median longitudinal plane of the child restraint fixture installed in the respective seating position; and

(b) **Forward limitation:**

By a plane perpendicular to the plane given by the child restraint fixture bottom surface and perpendicular to the median longitudinal plane of the child restraint fixture, 695 mm apart from the plane passing through the centerlines of the ISOFIX lower anchorages and being perpendicular to the CRF bottom surface; and

(c) **Rearward limitation:**

(i) Above the level of the bottom surface of the child restraint fixture by the front surface of the child restraint fixture, and

(ii) Below the level of the bottom surface of the child restraint fixture by a plane perpendicular to the plane given by the child restraint fixture bottom surface and perpendicular to the median longitudinal plane of the child restraint fixture, 585mm apart from the plane passing through the centerlines of the ISOFIX lower anchorages and being perpendicular to the CRF bottom surface; and

(c) **Height limitation:**

(i) Above the level of the bottom surface of the child restraint fixture by a plane which is parallel to the child restraint bottom surface and 85 mm above this surface, and

(ii) below the level of the bottom surface of the child restraint fixture by the upper surface of the vehicle floor (incl. trim, carpet, foam, etc.).

The pitch angle used for the geometrical assessment above shall be as measured in paragraph 5.2.3.4. of Regulation No. 14.

There shall be no interference between the support leg installation assessment volume and any vehicle part.

Compliance with this requirement can be proven by a physical test or computer simulation or representative drawings."

Annex 17

The title, amend to read:

"Requirements for the installation of safety-belts and restraint systems for adult occupants of power-driven vehicles on forward facing seats, ~~and~~ for the installation of ISOFIX child restraint systems **and i-size child restraint systems.**"

Paragraph 1.1., amend to read:

"1.1. The vehicle manufacturer shall include in the vehicle handbook advice on the suitability of each passenger seating position for ...

For each forward-facing passenger seating position, and for each ISOFIX position, the vehicle manufacturer shall either:

(a) Indicate that the seating position is suitable for child restraints of the "universal" category (see paragraph 1.2. below);

...

(g) Indicate the mass group(s) of the children which shall not be carried in that seating position.

The vehicle manufacturer shall identify within the handbook each seating position which is also suitable for the accommodation of an i-Size child restraint system (see paragraph 1.3 below).

If a seating position ...

..."

Paragraph 1.2., amend to read:

"1.2. ... seating position..."

Insert a new paragraph 1.3., to read:

"1.3. An i-Size child restraint means a child restraint approved to the i-Size category of Regulation No. [XXX]. Seating positions, which are indicated by the vehicle manufacturer as being suitable for the installation of i-Size child restraints systems shall comply with the provisions of Appendix 2 of this annex. Where applicable, any restriction on the simultaneous use on adjacent positions of ISOFIX child restraint systems or i-Size child restraint systems and/or between ISOFIX positions, i-Size positions and adult seating positions shall be reported in the table 2 of Appendix 3 to this annex."

Annex 17- Appendix 2

The title, amend to read:

"Provisions concerning the installation of forward-facing and rearward-facing ISOFIX child restraint systems of universal and semi-universal categories installed on ISOFIX or i-size positions"

Paragraphs 1.1. to 2.2., amend to read:

"1.1. The test procedure ... semi-universal categories, **as well as to determine the suitability of i-Size seating positions for installing i-Size child restraint systems.**

1.2. The tests may be carried out in the vehicle or in a representative part of the vehicle.

For i-Size seating positions, compliance with the i-Size support leg installation requirements may be assessed by a physical test, computer simulation or representative drawings.

2. Test procedure
- For any ISOFIX position in the vehicle, as indicated by the ~~car~~-vehicle manufacturer, in table 2 of Appendix 3, **as well as for any i-Size seating position if any, as indicated by the vehicle manufacturer in table 3 of Appendix 3**, it has to be checked that it is possible to accommodate the corresponding child restraint fixture(s) (CRF) **and additionally in case of an i-Size seating position, the i-Size support leg installation assessment volume**:
- 2.1. When checking a CRF, on a seat, **with or without i-Size support leg installation assessment volume**, this seat may be adjusted longitudinally to its rearmost position and in its lowest position.
- 2.2. Adjust the seat-back angle ...shall be used.
- When checking a CRF, on a rear seat, **with or without i-Size support leg installation assessment volume**, the vehicle seat"

Paragraph 2.4., amend to read:

- "2.4. Place the CRF, **with or without i-Size support leg installation assessment volume**, on the ISOFIX or **i-Size** position."

Paragraph 2.6., amend to read:

- "2.6. Attach the CRF, **with or without i-Size support leg installation assessment volume**, to the ISOFIX anchorages system."

Paragraphs 3 to 3.1., amend to read:

- "3. Requirements
- The following testing conditions only apply for the CRF(s), **with or without i-Size support leg installation assessment volume**, when accommodated in the ISOFIX **and/or i-Size** position. It is not required that the CRF(s), **with or without i-Size support leg installation assessment volume**, shall be able to move in and out of the ISOFIX **and/or i-Size** position under these conditions.
- 3.1. It has to be possible to accommodate the CRF(s), **with or without i-Size support leg installation assessment volume**, without interference with the vehicle interior. The CRF base shall have a pitch angle of $15^\circ \pm 10^\circ$, above the horizontal plane passing through the ISOFIX anchorages system."

Paragraph 3.3., amend to read:

- "3.3. Should the above ... These alternative positions shall be included as information in table 2 **and/or 3** given in Appendix 3 to this annex. **Passenger seats in front of i-Size seating positions may also be displaced to a position forward of the normal position of use. In such cases, the vehicle manufacturer shall provide information in the vehicle handbook, that the respective passenger seat shall not be occupied in such positions of displacement.**"

Paragraph 3.4., amend to read:

- "3.4. Should the above ... be included in table 2 **and/or 3** of Appendix 3 of this annex."

Figures 1 to 7, item 2 of the Key, amend to read:

"Key

1. ...
2. Dashed line marks area where a support leg, or similar, of a specific vehicle CRS is allowed to protrude.
- ..."

Insert new Figures 8 and 9, to read:

"Figure 8

Side view of the i-Size support leg installation assessment volume for assessing compatibility of the i-Size seating positions with support legs of i-Size child restraint systems

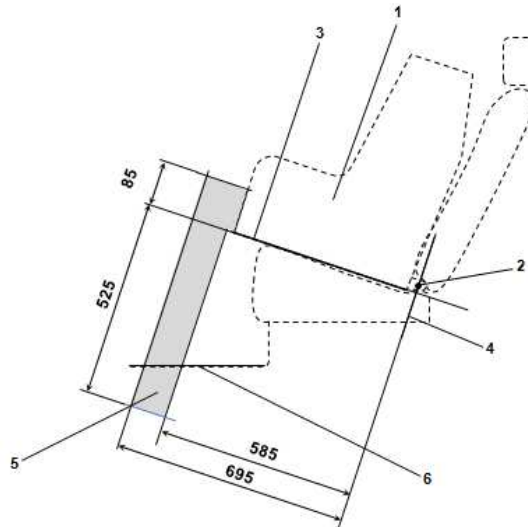

Key:

1. **Child Restraint Fixture (CRF).**
2. **ISOFIX low anchorages bar.**
3. **Plane formed by the bottom surface of the CRF when installed in the designated seating position.**
4. **Plane passing through the lower anchorage bar and oriented perpendicular to the median longitudinal plane of the CRF and perpendicular to the plane formed by the bottom surface of the CRF when installed in the designated seating position.**
5. **i-Size support leg installation assessment volume representing the geometrical boundaries for an i-Size ISOFIX child restraint system support leg.**
6. **Vehicle floor.**

Notes:

Drawing not to scale.

Figure 9

3D view of the i-Size support leg installation assessment volume for assessing compatibility of the i-Size seating positions with support legs of i-Size child restraint systems

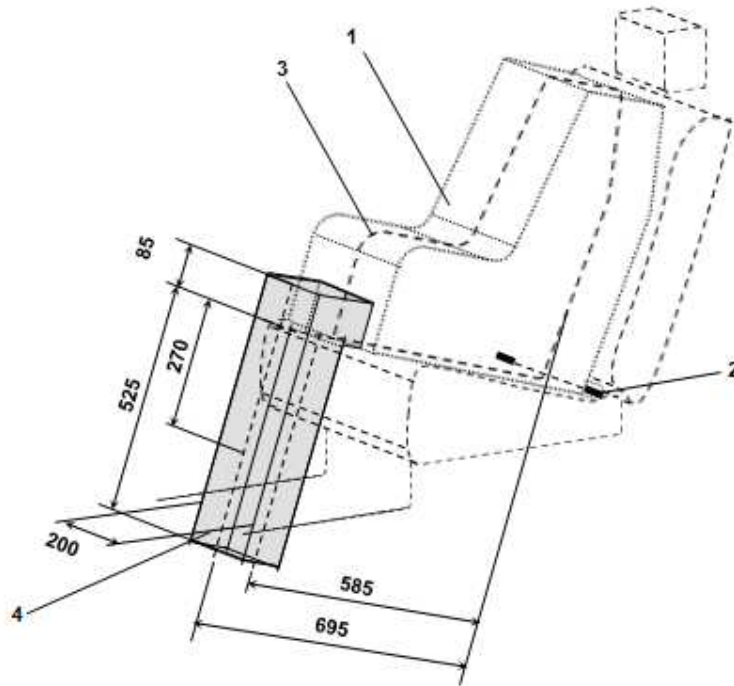

Key:

1. Child Restraint Fixture (CRF).
2. ISOFIX low anchorages bar.
3. Median longitudinal plane of the CRF.
4. i-Size support leg installation assessment volume.

Notes:

Drawing not to scale."

Insert a new Table 3, to read:

"Table 3

Table of vehicle handbook information on i-Size child restraint systems for installation in various seating positions

		<i>Seating position</i>								
		Front Passenger Outboard	Front Passenger Centre	Rear Outboard Left	Rear Outboard Right	Rear Centre	Intermediate Outboard Left	Intermediate Outboard Right	Intermediate Centre	
i-Size Child Restraint Systems										
<p>Note: Orientation is normal driving direction; columns for seating positions not available in a vehicle can be deleted.</p>										
<p><i>Key of letters to be inserted in the above table:</i></p>										
i-U	=	Suitable for i-Size "universal" Child Restraint Systems forward and rearward facing.								
i-UF	=	Suitable for forward-facing i-Size "universal" Child Restraint Systems only.								
X	=	Seating position not suitable for i-Size "universal" Child Restraint Systems.								

II. Justification

1. The above proposal, together with the draft amendments to Regulation No. 14 (ECE/TRANS/WP.29/GRSP/2011/22), introduce vehicle requirements related to the draft new CRS Regulation (ECE/TRANS/WP.29/GRSP/2011/21), specifically i-Size child restraint systems. These proposals also align the definitions for child restraint systems with the new CRS draft regulation.

2. This proposal shall ensure detailed geometrical compatibility of i-Size CRS, characterized by the F2X and R2 envelopes, as well as the i-Size support leg installation assessment volume. Furthermore, the amendments describe, the method by which the manufacturer must inform the customer about i-Size seating positions.