



Economic and Social Council

Distr.: General
2 March 2011

English only

Economic Commission for Europe

Inland Transport Committee

World Forum for Harmonization of Vehicle Regulations

153rd session

Geneva, 8–11 March 2011

Item 8.6 of the provisional agenda

Other business – Revision of the Consolidated Resolution on the Construction of Vehicles (R.E.3)

Revision of the Consolidated Resolution on the Construction of Vehicles (R.E.3)

Note by the Secretariat*

Corrigendum

Page 2, Annexes, Appendix 1

For Prescription read Description.

Page 4, Introduction, second subparagraph correct to read:

"**Paragraphs** 1 and 2 contain general definitions and the classification used in the documents referred. Chapter 3 indicates the scope of the Regulation(s) and Rule(s). Tables of **paragraphs** 4 to 7 contain the main requirements for the construction of vehicles so far established and already included into Regulation(s) and Rule(s) by the World Forum. Similar requirements are grouped. For any requirement or group of requirements references are made to the relevant Regulations, identified by the number allocated to them by the 1958 Agreement, to the still valid Recommendations reproduced in **paragraph** 8 and to the Standard Annexes to Regulations reproduced in the annexes to this **Resolution. Annex 7** includes, as complementary information, an updated list of the distinguishing numbers allocated to Contracting Parties by the 1958 Agreement."

* In accordance with the programme of work of the Inland Transport Committee for 2010–2014 (ECE/TRANS/208/, para. 106 and ECE/TRANS/2010/8, programme activity 02.4), the World Forum will develop, harmonize and update Regulations in order to enhance the performance of vehicles. The present document is submitted in conformity with that mandate.

Page 5, notefoot 2

For item H read paragraph 1.8.

Page 31, table, item 124, correct to read:

"Uniform provisions concerning the approval of wheels for passenger cars **and their trailers.**"

Page 37, paragraph 7, table, item F, correct to read:

"Vehicle alarm **and** anti-theft systems."

Page 38, paragraph 8.1.1.1., correct to read:

"A single motor vehicle may be maintained in service only if the respective performance of the service, emergency **and** parking braking devices are at least equal to 90 % of the performance prescribed for a new motor vehicle in Regulations Nos. 13 and 13-H."

Page 42, move paragraph 8.7.3.5., below Figure 1.

Page 42, paragraph 8.7.5.1.1., correct to read:

"The test device shall be as shown in **Figure 5.**"

Page 43, paragraph 8.7.5.2.

For (see appendix, figure 6) read (see Figure 6).

Page 43, notefoot 5

For item H read paragraph 1.8.

Page 47, paragraph 8.10.

*For listed paragraph 5 read listed **in** paragraph 5.*

Pages 55-56,

For former 8.29.8.1. to 8.29.8.11. read 8.29.7.1. to 8.29.7.11.

Page 60, paragraph 8.30.7.2.2.

*For figures 1 and figures 2 read **Figure 8 and Figure 9.***

Page 66, paragraph 8.37.2.1.

Delete the third subparagraph.

Page 72, Figure 11

Delete captions "Microphone position A" below each figure.

Page 77, paragraph 4.12.

Delete space between the two first lines.

Page 78, Appendix 1, in the title

For Prescription read Description.

Page 84, paragraph 2.3.2., correct to read:

"2.3.2. sample B

| | |
|-------------------------------------|-------------|
| B4: in the case of A2 | |
| one direction indicator more than | 0 % |
| but not more than | 20 % |
| one direction indicator more than | 20 % |
| B5: in the case of A2 | |
| both direction indicators more than | 20 % |
| B6: in the case of A2 | |
| one direction indicator | 0 % |
| one direction indicator more than | 30 % |

Page 86, Figure 1, correct as follows:

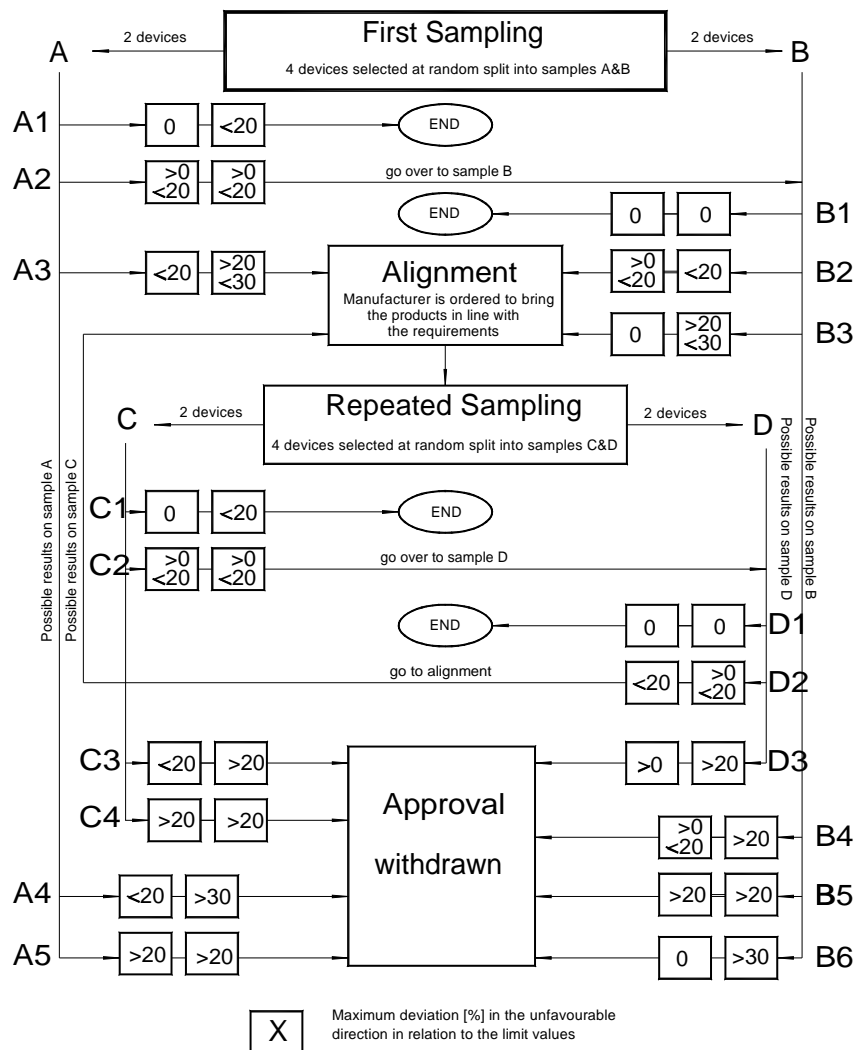

Page 92, paragraph 2.2.3.1.

Delete space between the third and fourth line.

Page 92, paragraph 2.2.3.2.

Delete space between the third and fourth line.

Page 93, paragraph 2.3.3.

Delete space between the second and third line, and between the fourth and the fifth line.

Page 96, paragraph 2, table, item 2.1.

For (para. 2.6.1.1.1.) read (para. 2.6.1.1.)

Page 100, paragraph 6, correct to read:

"6. Results

 The five values obtained shall be arranged in order and the median value taken as the result of the measurement. This value shall be expressed in Newtons **per centimetre** of width of the tape."

Page 105, Annex 7, second subparagraph

*For 34 Bulgaria, 35 (vacant) read 34 **for** Bulgaria, 35 **for Kazakhstan**.*