

Full texts of amendments to the proposals adopted during the forty-seventh session of the Working Party on Passive Safety

Contents

Annexes

I.	List of informal documents (GRSP-47-...) distributed without an official symbol during the session	2
II.	Amendments to gtr No. 9.	6
III.	Amendments to Regulation No. 12	8
IV.	Amendments to Regulation No. 16	25
V.	Amendments to Regulation No. 44	26
VI.	Amendments to Regulation No. 94	27
VII.	Amendments to Regulation No. 95	43
VIII.	Amendments to draft Regulation on pedestrian safety	58
IX.	List of the informal groups of GRSP.....	59

Annexes

Annex I

List of informal documents (GRSP-47-...) distributed without an official symbol during the session

<i>No.</i>	<i>Transmitted by</i>	<i>Agenda item</i>	<i>Language</i>	<i>Title</i>	<i>Follow-up</i>
01/ Rev.3	France	9	E	Proposal for the 04 series of amendments to Regulation No. 12 (Steering mechanism)	(a)
02/ Rev.3	France	17	E	Proposal for 02 series of amendments to Regulation No. 94 (Frontal collision)	(a)
03/ Rev.3	France	18	E	Proposal for 03 series of amendments to Regulation No. 95 (Lateral collision)	(a)
04/ Rev.1	EC	17	E	Proposal for supplement 4 to the 01 series of amendments to Regulation No. 94 (Frontal collision)	(b)
05	Chair of GRSP	1	E	Agenda running order of GRSP 47th session	(a)
06/ Rev.1	France	23	E	Draft amendment to ECE/TRANS/WP.29/GRSP/2010/26 (CRS)	(c)
07	Germany	15	E	Approval of a child restraint not in line with the requirements of Regulation No. 44 (Child restraints systems)	(a)
08	United States of America	2	E	Proposal fro Amendment 1 to global technical regulation No. 1 (Door locks and door retention components)	(b)
09	Consumer International, FIA, FIA Foundation, ANEC	17	E	Comments from consumer groups to ECE/TRANS/WP.29/GRSP/2010/12	(c)
10	Consumer International, FIA, FIA Foundation, ANEC	15	E	Pirated child restraint system with false ECE approval marks	(a)
11	Chair of GRSP	23	E	Accidental death of a child in United Kingdom likely due to child restraints system	(a)

<i>No.</i>	<i>Transmitted by</i>	<i>Agenda item</i>	<i>Language</i>	<i>Title</i>	<i>Follow-up</i>
12	Japan	4.1	E	Status Report on Flexible Pedestrian Legform Impactor Technical Evaluation Group (Flex-TEG)	(a)
13	Japan	4.1	E	Proposal for corrigendum to proposal to develop amendments to global technical regulation No. 9 (pedestrian safety) (ECE/TRANS/WP.29/GRSP/2010/2)	(a)
14	Chair of frontal impact informal group	17	E	Status report of the informal group on frontal impact	(a)
15	Germany	19	E	Proposal to set up an Expert Group on the construction and functional safety of high voltage vehicles to establish requirements for the RESS (Rechargeable Energy Storage System)	(c)
16/ Rev.1	Japan	3	E	First progress report of the informal working group on gtr No.7 (head restraint) Phase 2	(d)
17/ Rev.1	Japan	3	E	Head restraint gtr Phase 2 status and open issues	(a)
18/ Rev.2	United States of America	4.1	E	Proposal for amendments to global technical regulation No. 9 (Pedestrian safety)	(a)
19	France	17	E	Proposal from the expert from France based on the outcome of the electric vehicle post crash provision group of interested experts	(a)
20	United States of America and EC	2	E	Proposal for an amendment to global technical regulation No. 1 (Door locks and door retention components)	(a)
21	EC	17	E	Proposal for corrigendum 3 to the 01 series of amendments to Regulation No. 94 (Frontal collision)	(a)
22	France	9, 17 and 18	E	Specifications and performance criteria of Regulations Nos. 12, 94 and 95	(a)
23	OICA	8	E	Proposal for Supplement 2 to the 03 series of amendments to Regulation No. 11	(b)
24	OICA	22	E	Proposal of amendments to ECE/TRANS/WP.29/GRSP/2009/17 - draft UNECE Regulation on pedestrian safety	(a)
25	OICA	23	E	Comments to GRSP-47-06	(a)

<i>No.</i>	<i>Transmitted by</i>	<i>Agenda item</i>	<i>Language</i>	<i>Title</i>	<i>Follow-up</i>
26	Japan	10	E	Proposed corrigendum to Regulation No. 14 (Safety-belt anchorages)	(b)
27	Chair of the informal group on CRS	23	E	Status report of the informal group on child restraints systems	(a)
28	Australia	5	E	Establishment of an Informal Group to examine a proposal for a pole side impact global technical regulation	(a)
29/ Rev.2	United Kingdom	9, 17 and 18	E	Transitional Provisions associated with the proposed revisions to Regulations Nos. 12, 94 and 95.	(a)
30	United States of America	5	E	Draft 1st progress report informal working group to develop the 50th male and 5th female WorldSID dummies	(d)
31	United States of America	5	E	US Side Impact Protection Rule	(a)
32	Japan	4.1	E	Proposal for amendments to global technical regulation No. 9	(c)
33	OICA and Germany	10	E	Proposal of amendments to ECE/TRANS/WP.29/GRSP/2010/8	(c)
34	Japan	4.1	E	Proposal for amendments to global technical regulation No. 9	(a)
Consideration of informal documents from the previous GRSP sessions (referring to the agenda item of the current GRSP session)					
46-40	EC	8	E	Proposal for draft amendments to ECE/TRANS/WP.29/GRSP/2009/22 (Regulation No. 11 - Door latches and hinges)	(a)
46-03	The Netherlands	8	E	Proposal of amendments to Regulation No. 11 (Door latches and hinges)	(a)
45-13	Germany	10	E	Proposal for draft amendments to Regulation No. 14 - Safety-belt anchorages	(a)
46-14	Germany and Belgium	10	E	Proposal for Supplement 2 to the 07 series of amendments to Regulation No. 14 (Safety-belt anchorages)	(a)
46-02	Germany	11	E	Proposal of amendments to Regulation No. 16 (Safety-belts)	(a)
46-15	Germany and Belgium	11	E	Proposal for Supplement 1 to the 06 series of amendments to Regulation No. 16 (Safety-belts)	(a)

<i>No.</i>	<i>Transmitted by</i>	<i>Agenda item</i>	<i>Language</i>	<i>Title</i>	<i>Follow -up</i>
46-19	Germany	16	E	Proposal for amendments to Regulation No. 80 (Strength of seats(buses))	(a)
44-26	Chair of the GRSP Frontal Impact Informal Group	21.1	E	GRSP 46th session – Status report of the informal group	(a)
44-29	Spain	21.2	E	Status of CRS in buses and coaches	(a)

Notes:

- (a) Consideration completed or superseded
- (b) Continue consideration at the next session with an official symbol
- (c) Continue consideration at the next session as informal document
- (d) Adopted and to be submitted to WP.29

Annex II

Amendments to gtr No. 9

Amendments adopted to ECE/TRANS/WP.29/GRSP/2010/6
(see para. 9 of the report)

Statement of technical rationale and justification

Paragraph 55, amend to read:

“55. While this approach maximizes the discretion of jurisdictions to decide whether vehicles should be excluded from the gtr for feasibility or practical reasons, or because there is no safety need to regulate the vehicles, the group also decided to recommend excluding one unique vehicle type from the regulation. The test procedures in the gtr are based largely on the classic vehicle shape with a long bonnet. Certain vehicles, generally cargo vehicles, have a very short bonnet and a front shape that is very close to the vertical. Because of the short, vertical bonnet, the design leaves very little soft space once the hinges, latches, and other hardware are considered. There are additionally feasibility concerns for the bumpers of these vehicles. The different shape of the front leaves little room to incorporate existing countermeasures, such as those used on passenger vehicles, and new countermeasures have not been identified. The pedestrian kinematics with these vehicles may be very different. The head to bonnet impact is occurring earlier and leg injuries are occurring at a reduced frequency than with traditional long bonnet vehicles. ~~and, in addition, there are difficulties in applying the head tests to these vehicles, particularly with regard to determination of test zone reference lines.~~¹⁵ For these reason, the group recommends that those vehicles of category 1-2 and category 2, where the distance, measured longitudinally on a horizontal plane, between the transverse centre line of the front axle and the R-point of the driver's seat is less than ~~1,000~~ 1,100 mm, be exempt from the requirements of the regulation. ~~In addition, some of the group members raised a concern that this exemption could create inconsistencies in the market if category 1-1 vehicles were not treated in a similar manner and thus, consideration should be given to the inclusion of this category of vehicles in the recommended exemption.~~ To prevent inconsistencies in the market, Contracting Parties can exempt category 1-1 vehicles if they have components of the front structure that are interchangeable with exempted category 1-2 and category 2 vehicles. The group agreed to recommend allowing Contracting Parties this option even though not all Contracting Parties have these vehicles in their fleet and were therefore not able to fully evaluate the exemption.”

Paragraph 74, the reference to footnote ¹⁵ and footnote ¹⁵, renumber as footnote ¹⁶

Paragraph 78, the reference to footnote ¹⁶ and footnote ¹⁶, renumber as footnote ¹⁷

Paragraph 99, the reference to footnote ¹⁷ and footnote ¹⁷, renumber as footnote ¹⁸

Paragraph 100, the reference to footnote ¹⁸ and footnote ¹⁸, renumber as footnote ¹⁹

Paragraph 106, the reference to footnote ¹⁹ and footnote ¹⁹, renumber as footnote ²⁰

Paragraph 107, the reference to footnote ²⁰ and footnote ²⁰, renumber as footnote ²¹

¹⁵ Informal document No. GRSP-45-25

Paragraph 109, the reference to footnote ²¹ and footnote ²¹, renumber as footnote ²²

Paragraph 130, the reference to footnote ²² and footnote ²², renumber as footnote ²³

Section 10, amend to read:

“10. APPENDIX–REFERENCE DOCUMENTS USED BY THE WORKING GROUP

...

...

INF GR/PS/188 Draft meeting minutes of the 100th meeting

INF GR/PS/189 Attendance list 10th meeting

**GRSP-47-18/Rev.2 (USA) Proposal for amendments to global technical regulation
No. 9 (Pedestrian Safety)**

”

Text of the regulation

Paragraph 2.1., amend to read:

“2.1. This global technical regulation...”

**Amendments adopted to ECE/TRANS/WP.29/GRSP/2010/5
(see para. 9 of the report)**

...

Paragraph 3, amend to read:

3. {At its forty-seventh session, GRSP recommended the adoption by AC.3 of a draft Amendment 1 to gtr No. 9 for its establishment in the Global Registry at its November 2010 session. This amendment enlarges the geometric criteria to exempt flat front vehicles of category 1-1 under certain conditions.}

Annex III

Amendments to Regulation No. 12

Amendments adopted to ECE/TRANS/WP.29/GRSP/2010/19 (see para. 16 of the report)

Contents, insert a new Annex 7, to read:

“... ”

Annex 7 - **Test Procedures for the Protection of the occupants of vehicles operating on electrical power from high voltage and electrolyte spillage.**

~~Appendix 1 – Protection against direct contacts of parts under voltage”~~

Appendix 1 – Jointed Test Finger (IPXXB) ”

Paragraph 1, amend to read:

“1. **Scope**

1.1. **This Regulation applies to the behaviour of the steering mechanism and to the electrical power train operating on high voltage as well as the high voltage components and systems which are galvanically connected to the high voltage bus of the electric power train, of motor vehicles of category M1, and vehicles of category N1 with a maximum permissible mass less than 1,500 kg, with regard to the protection of the occupants in a frontal collision.”**

Paragraph 2.2.2.1., amend to read:

“2.2.2.1. **The structure, dimensions, lines and constituent materials of that part of the vehicle forward of the steering control.”**~~Dimensions, mass, structure of the vehicle, forms and constituent materials, place of the components of the electric power train propulsion system, place of the battery or of the parts of propulsion battery the rechargeable energy storage system (RESS).”~~

Insert a new paragraph 2.2.2.2., to read:

“2.2.2.2. **The locations of the RESS, in so far as they have a negative effect on the result of the impact test prescribed in this Regulation,”**

Paragraph 2.2.2.2.(former)., renumber as 2.2.2.3.

Paragraph 2.16., amend to read:

“2.16. **“Passenger compartment with regard to driver protection”** means the space for occupant accommodation, bounded by the roof, floor, side walls, doors, outside glazing, front bulkhead, and the plane of the rear compartment bulkhead or the plane of the rear seat back support, and if necessary any partition of the tray(s) containing the monoblocs of the electric vehicle's propulsion battery; ~~For the sake of protection of occupants from high voltage and electrolyte spillage according to Annex 7 a different definition (see paragraph 2.36.) is applied.”~~

Insert new paragraphs 2.16.1. and 2.16.2., to read:

“2.16.1. **“Passenger compartment with regard to occupant protection”** means the space for occupant accommodation, bounded by the roof, floor, side

walls, doors, outside glazing and front bulkhead and the plane of the rear compartment bulkhead or the plane of the rear-seat back support.

- 2.16.2. “*Passenger compartment for electric safety assessment*” means the space for occupant accommodation, bounded by the roof, floor, side walls, doors, outside glazing, front bulkhead and rear bulkhead, or rear gate, as well as by the electrical protection barriers and enclosures provided for protecting the power train from direct contact with high voltage live parts.”

Paragraph 2.18., amend to read:

- “2.18. “*Mass of the vehicle in running order*” means the mass of the vehicle unoccupied and unladen but complete with fuel, coolant, lubricant tools and spare wheel, if provided as standard equipment by the vehicle manufacturer, and RESS. ~~propulsion battery tray(s) including the monoblocs of the electric vehicle's propulsion battery.~~”

Paragraphs 2.19. to 2.21., shall be deleted.

Insert new paragraphs 2.19. to 2.38., to read:

- ~~2.34.~~2.19. “*High Voltage*” means the classification of an electric component or circuit, if its -working voltage is > 60 V and ≤ 1500 V **direct current** (DC) or > 30 V and ≤ 1000 V **alternating current** (AC) root – mean – square (rms),
- 2.20. “*Rechargeable energy storage system (RESS)*” means rechargeable energy storage system ~~that~~ **which** provides ~~the~~ electrical energy for propulsion,
- ~~2.32.~~2.21. [~~“*Electrical Protection Barrier*” / *Protection Shielding* / *Shielding* / *Barrier-el/ High Voltage Protection*”]~~ means the part providing protection against **any** direct contact to the **high voltage** live parts, ~~from any direction of access,~~
- ~~2.19.~~2.22. “*Electrical power train*” means the electrical circuit which includes the traction motor(s), and may **also** include the RESS, the electrical energy conversion system, the electronic converters, the associated wiring harness and connectors, and the coupling system for charging the RESS,
- ~~2.25.~~2.23. “*Live parts*” means conductive part(s) intended to be electrically energized in normal use,
- ~~2.28.~~2.24. “*Exposed conductive part*” means the conductive part which can be touched under the provisions of the protection ~~degree~~ IPXXB, and which becomes electrically energized under isolation failure conditions,
- ~~2.24.~~2.25. “*Direct contact*” means the contact of persons with **high voltage** live parts,
- 2.26. “*Indirect contact*” means the contact of persons with exposed conductive parts,
- 2.27. “*Protection IPXXB-degree*” means ~~the~~ protection **from contact with high voltage live parts** provided by **either an electrical protection barrier or an enclosure related to the contact with live parts by a test probe, such as a and tested using a Jointed Test Finger (IPXXB) as defined—described in paragraph 4 Appendix 1 of Annex 7,**
- ~~2.30.~~2.28. “*Working voltage*” means the highest value of an electrical circuit voltage root-mean-square (rms), specified by the manufacturer, which may occur between any conductive parts in open circuit conditions or under normal

operating conditions. If the electrical circuit is divided by galvanic isolation, the working voltage is defined for each divided circuit, respectively,

- ~~2.23.2.29.~~ “Coupling system for charging the rechargeable energy storage system (RESS)” means the electrical circuit used for charging the RESS from an external electrical power supply including the vehicle inlet,
- ~~2.31.2.30.~~ “Electrical chassis” means a set made of conductive parts electrically linked together, whose **electrical** potential is taken as reference,
- ~~2.29.2.31.~~ “Electrical circuit” means an assembly of connected **high voltage** live parts which is designed to be electrically energized in normal operation,
- ~~2.21.2.32.~~ “Electrical energy conversion system” means a system (e.g. fuel cell) that generates and provides electrical energy for electrical propulsion,
- ~~2.22.2.33.~~ “Electronic converter” means a device capable of controlling and/or converting electrical power for electrical propulsion,

- ~~2.33.2.34.~~ “Enclosure” means the part enclosing the internal units and providing protection against **any** direct contact, ~~from any direction of access,~~
- 2.35. “High Voltage Bus” means the electrical circuit, including the coupling system for charging the RESS that operates on a high voltage,
- ~~2.36.~~ ~~“Passenger compartment for electric safety assessment” means the space for occupant accommodation, bounded by the roof, floor, side walls, doors, window glass, front bulkhead and rear bulkhead, or rear gate, as well as by the barriers and enclosures provided for protecting the power train from direct contact with high voltage live parts,~~
- ~~2.37.2.36.~~ “Solid insulator” means **the** insulating coating of wiring harnesses provided in order to cover and **prevent** ~~protect~~ the **high voltage** live parts **from any** ~~against~~ direct contact. ~~from any direction of access.~~ **This includes** covers for insulating the **high voltage** live parts of connectors; and varnish or paint for the purpose of insulation,
- 2.37. “Automatic disconnect” means a device that when triggered, galvanically separates the electrical energy sources from the rest of the high voltage circuit of the electrical power train,”
- 2.38. “Open type traction battery” means a type of battery requiring liquid and generating hydrogen gas released to the atmosphere.”

Paragraphs 3.1.2.6. and 3.1.2.7., amend to read:

~~“3.1.2.6. ... Regulation No. 94, 01 series of amendments, if the application~~

~~3.1.2.7. ... Regulation No. 94, 01 series of amendments, if the application”~~

Insert a new paragraph 3.1.2.8., to read:

“3.1.2.8. A ~~general~~ **General** description of the RESS ~~electric power source type, and location~~ and the electrical power train (e.g. hybrid, electric).”

Paragraph 3.2.2.3., amend to read:

~~“3.2.2.3. evidence that the steering control complies with the specifications of paragraphs 5.2.1.4. and 5.2.1.5. of Regulation No. 94, 01 series of amendments, if the application for approval is submitted by the applicant pursuant paragraph 5.2.1. below.”~~

Paragraph 4.2.2., amend to read:

“4.2.2. An approval number shall be assigned to each type approved. Its first two digits (at present ~~0304~~ corresponding to the ~~0304~~ series of amendments entered into force on 24 August 1993) shall...”

Paragraph 4.3.2., amend to read:

“4.3.2. An approval number shall be assigned to each type approved. Its first two digits (at present ~~0304~~ corresponding to the ~~0304~~ series of amendments) shall”

Paragraph 4.3.4.3., amend to read:

“4.3.4.3. the symbol ~~R94-0102~~ in the case of an approval pursuant paragraph 5.2.1. below.”

Paragraph 5.1.1., amend to read:

“5.1.1. ~~{~~Additionally, vehicles equipped with electrical power train shall meet paragraph 5.5. ~~in addition.~~ This could be demonstrated in a separate **frontal impact-crash** test at the request of the manufacturer **after validation by the Technical Service**, given that the electric components do not influence the driver's protection performance of the vehicle type as defined in this Regulation.~~}~~”

Paragraphs 5.1.1.1 and 5.1.1.2., shall be deleted.

Paragraph 5.1.2., amend to read:

“5.1.2. Specifications of paragraph 5.1. above are deemed to be met if the vehicle equipped with such a steering system complies with the specifications of paragraph 5.2.2. of Regulation No. ~~94-01 series of amendments.~~”

Paragraph 5.2.1., amend to read:

“5.2.1. If the steering control is fitted with a steering wheel airbag, specifications of paragraph 5.2. above are deemed to be met if the vehicle equipped with such a steering system complies with the specifications of paragraphs 5.2.1.4. and 5.2.1.5. of Regulation No. ~~94, 01 series of amendments.~~”

Insert new paragraphs 5.5. to 5.6., to read:

“5.5. **Following the test conducted in accordance with the procedure defined in Annex 3 to this Regulation** the electrical power train operating on high voltage ~~as well as~~ and the high voltage components and systems which are galvanically connected to the high voltage bus of the electrical power train shall meet the following requirements:

5.5.1. Protection against electrical shock

After the impact at least one of the ~~four following~~ criteria specified in paragraph 5.5.1.1. to paragraph 5.5.1.4.2. shall be met.

If the vehicle has an automatic disconnect function **or device(s) that galvanically divide the electrical power train circuit during driving condition**, at least one of the **following** criteria shall apply to the **disconnected circuit** or to each divided ~~portion~~ **circuit** individually after the disconnect function is activated.

However criteria defined in 5.5.1.4. shall not apply if more than a single potential of a part of the high voltage bus is not protected under the conditions of protection IPXXB.

In the case that the test is performed under the condition that part(s) of the high voltage system are not energized, the protection against electrical shock shall be proved by either 5.5.1.3. or 5.5.1.4. for the relevant part(s).

5.5.1.1. Absence of high voltage

The voltages **Vb, V1 and V2** of the high voltage buses shall be equal or less than 30 VAC or 60 VDC as specified in paragraph 2 of Annex 7.

5.5.1.2. Low electrical energy

The total energy Energy (TE) on the high voltage buses shall be less than 2.0 joules when measured according to the test procedure as specified in paragraph 3 of Annex 7 with the formula (a). Alternatively the total energy (TE) may be calculated by the measured voltage Vb of the high voltage bus and the capacitance of the X-capacitors (Cx) specified by the manufacturer according to formula (b) of paragraph 3 of Annex.

The energy stored in the Y-capacitors (TE_{y1}, TE_{y2}) shall also be less than 2.0 joules. This shall be calculated by measuring the voltages V1 and V2 of the high voltage buses and the electrical chassis, and the capacitance of the Y-capacitors specified by the manufacturer according to formula (c) of paragraph 3 of Annex 7

5.5.1.3. Physical protection

For protection **against direct contact with high voltage** live parts, the protection ~~degree~~ IPXXB shall be provided.

In addition, **for protection against electrical shock which could arise from indirect contact**, the resistance between all exposed conductive parts and the electrical chassis shall be lower than 0.1 ohm when there is current flow of at least 0.2 ampere.

This requirement is satisfied if the galvanic connection has been **made established** by welding.

5.5.1.4. Isolation resistance

The criteria specified in the paragraphs 5.5.1.4.1. and 5.5.1.4.2. below shall be met.

The measurement shall be conducted in accordance with to paragraph 5 of Annex 7.

5.5.1.4.1. Electrical power train consisting of separate DC- or AC-buses

If **the** AC high voltage buses and **the** DC high voltage buses are galvanically isolated from each other, isolation resistance between the high voltage bus and the electrical chassis (**Ri, as defined in paragraph 5 of Annex 7**) shall have a minimum value of 100 Ω/V of the working voltage for DC buses, and a minimum value of 500 Ω/V of the working voltage for AC buses.

5.5.1.4.2. Electrical power train consisting of combined DC- and AC-buses

If **the** AC high voltage buses and **the** DC high voltage buses are galvanically connected isolation resistance between the high voltage bus and the electrical

chassis (**Ri, as defined in paragraph 5 of Annex 7**) shall have a minimum value of 500 Ω/V of the working voltage.

However, if the protection ~~degree~~ IPXXB is satisfied for all AC high voltage buses or the AC voltage is equal or less than 30 V after the vehicle impact ~~crash~~, the isolation resistance between the high voltage bus and the electrical chassis (**Ri, as defined in paragraph 5 of Annex 7**) shall have a minimum value of 100 Ω/V of the working voltage.

5.5.2. Electrolyte spillage

In the period from the impact until 30 minutes after no electrolyte from the {RESS} shall spill into the passenger compartment, and no more than {7 per cent} / ~~5.0 liters~~ of electrolyte shall spill from the {RESS} **except open type traction batteries outside the passenger compartment. For open type traction batteries no more than 7 per cent with a maximum of 5.0 liters shall spill outside the passenger compartment. The manufacturer shall demonstrate compliance in accordance with paragraph 6 of Annex 7.**

5.5.3. {RESS} retention

{RESS} located inside the passenger compartment shall remain in the location in which they are installed and {RESS} components shall remain inside {RESS} boundaries.

No part of any {RESS} that is located outside the passenger compartment **for electrical safety assessment** shall enter the passenger compartment during or after the impact test procedures.

The manufacturer shall demonstrate compliance in accordance with paragraph 7 of Annex 7.

5.6. **Specifications of Paragraphs 5.5. to 5.5.3. above are deemed to be met if the vehicle equipped with an electrical power train operating on high voltage complies with the specifications of paragraphs 5.2.8. to 5.2.8.3. of Regulation No. 94, 02 series of amendments.”**

Paragraph 6.1., amend to read:

“6.1. Compliance with the requirements of paragraphs 5.1. to 5.4. above shall be checked in accordance with the methods set out in Annexes 3, 4 and 5 to this Regulation. Compliance with the requirements of paragraph 5.5 above shall be checked in accordance with the methods set out in Annex 3 to this Regulation. All measurements should be done on the basis of ISO 6487-1987.”

Paragraphs 13.1. to 13.3.1., amend to read:

“[13.1. As from the date of entry into force of the 04 series of amendments, Contracting Parties applying this Regulation shall grant approvals only if the vehicle type to be approved meets the requirements of this Regulation as amended by the 03 or the 04 series of amendments.

13.2. Approval of vehicle type

13.2.1. As from the official date of entry into force of the 04 series of amendments, no Contracting Party applying this Regulation shall refuse to grant ECE approval under this Regulation as amended by the 04 series of amendments.

- 13.2.2. As from [24] months after the entry into force, Contracting Parties applying this Regulation shall grant ECE approvals only to those types of vehicle which comply with the requirements of this Regulation as amended by the 04 series of amendments.
- 13.2.3. Notwithstanding the above, Contracting Parties applying this Regulation may [continue to] grant ECE approvals to the 03 series of amendments for an additional [12] months provided that the manufacturer demonstrates, to the satisfaction of the Technical Service, that the vehicle provides equivalent levels of safety to those required by this Regulation as amended by the 04 series of amendments.
- 13.2.4. As from the date of entry into force, Contracting Parties applying this Regulation shall not refuse to grant extensions to approvals issued to the preceding series of amendments to this Regulation. However, as from [24] months after the entry into force of the 04 series of amendments extensions to approvals issued to the previous series of amendments shall not be granted in respect of vehicles having an electrical power train operating on high voltage
- 13.2.5. By way of derogation to the obligations of Contracting Parties applying this Regulation, where at the time of entry into force of the 04 series of amendments to this Regulation national requirements exist to address the safety provisions detailed in these amendments, those Contracting Parties may continue to permit the entry into service of vehicles approved to the preceding series of amendments and complying with the specific national requirements applying at that time. This derogation shall cease to be valid [24] months after the entry into force of the 04 series of amendments to this Regulation.
- As from [48] months after the entry into force of the 04 series of amendments to this Regulation, Contracting Parties applying this Regulation may refuse national or regional type approval and may refuse first national or regional registration (first entry into service) of a vehicle having an electrical power train operating on high voltage which does not meet the requirements of the 04 series of amendments to this Regulation.
- 13.3. Approvals of type of steering control
- 13.3.1. Even after the date of entry into force of the 04 series of amendments, approvals of the steering control to the preceding series of amendments to the Regulation shall remain valid and Contracting Parties applying the Regulation shall continue to accept them, and may continue to grant extensions of approvals to the 03 series of amendments.]”

Paragraph 13.3.2., shall be deleted

Paragraph 13.3.3. and 13.3.4., renumber as paragraphs 13.3.2. and 13.3.3.

Annex 2, amend to read:

“Annex 2

Arrangements of Approval Marks

Model A

(See paragraph 4.2.4. of this Regulation)

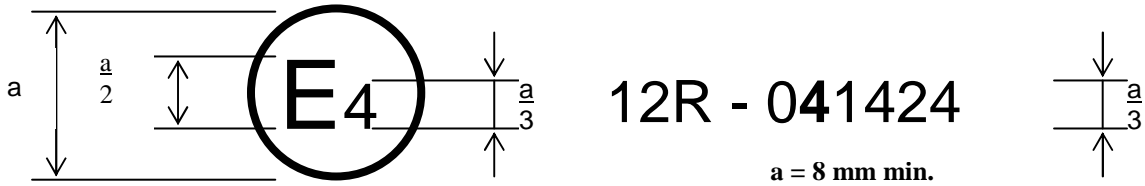

The above approval mark affixed to a vehicle shows that the vehicle type concerned has, with regard to the protection of the driver against the steering mechanism in the event of impact, been approved in the Netherlands (E4) pursuant to Regulation No. 12. The approval number indicates that the approval was granted according to the requirements of Regulation No. 12 as amended by the 03 04 series of amendments

Model B

(See paragraph 4.2.5. of this Regulation)

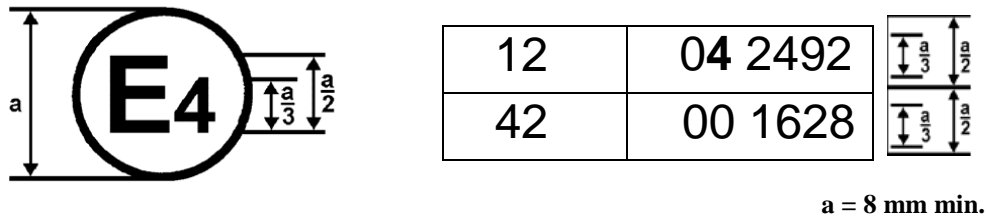

The above approval mark affixed to a vehicle shows that the vehicle type concerned has been approved in the Netherlands (E4) pursuant to Regulations Nos. 12 and 3942.¹ The approval numbers indicate that, at the dates when the respective approvals were given, Regulation No. 12 included the 0304 series of amendments and Regulation No. 3942 the 0400 series of amendments.

¹ The second number is given merely as an example

Model C

(See paragraph 4.3.4 of this Regulation)

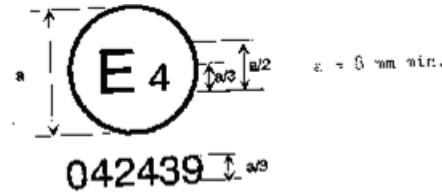

The above approval mark affixed to a steering control shows that the steering control type concerned has, with regard to the protection of the driver against the steering mechanism in the event of impact, been approved in the Netherlands (E4) pursuant to the relevant part of Regulation No. 12 as amended by the 0304 series of amendments.”

Annex 3,

Paragraph 2.4.2., amend to read:

“2.4.2. If the vehicle is driven by external means, the fuel feed system shall be filled to at least **90 per cent** of its capacity with a non-inflammable liquid having a density between 0.7 and 1.

This requirement does not apply for Hydrogen as fuel.

All the other systems (brake-fluid reservoirs, radiator, etc.) may be empty.”

~~At the request of the manufacturer it shall be allowed to perform the test with the engine or electric energy conversion system running and to allow for the fuel system to be modified in such a way that an appropriate amount of fuel can be used.~~

~~It shall be allowed by agreement between manufacturer and Technical Service to modify the fuel system so that an appropriate amount of fuel can be used to run the engine or the electrical energy conversion system.~~

~~This requirement does not apply to Hydrogen fuel tanks.~~

~~Alternative gas (i.e. helium gas) or alternative liquid (i.e. liquid nitrogen (LN2)) can be used instead of hydrogen gas or liquid hydrogen.~~

~~However the requirement of paragraph 5.2.8.1.3. shall be satisfied for the hydrogen conversion system disconnected by its automatic disconnect when this alternative is used.”~~

Paragraph 2.4.3., amend to read:

“2.4.3. **If the vehicle is driven by its own engine, the fuel tank shall be at least 90 per cent of a full load of fuel. All other reservoirs shall be filled to capacity.**

~~If the manufacturer so desires and the technical service agrees, the fuel feed to the engine may be provided from an auxiliary tank of small capacity.~~

It shall be allowed by agreement between manufacturer and Technical Service to modify the fuel system so that an appropriate amount of fuel can be used to run the engine or the electrical energy conversion system.

In such case, the fuel tank shall be filled to not less than 90 per cent of mass of a full load of fuel with a non-flammable liquid of a density between 0.7 and 1.

This requirement does not apply to Hydrogen fuel tanks.”

Insert new paragraphs 2.4.4. to 2.4.4.2.2, to read:

- “2.4.4. Electrical power train adjustment
- 2.4.4.1. The RESS shall be at any state of charge, which allows the normal operation of the power train as recommended by the manufacturer.
- 2.4.4.2. ~~[The high voltage system shall be energized.]~~**The electrical power train shall be energized with or without the operation of the original electrical energy sources (e.g. engine-generator, RESS or electric energy conversion system), however:**
- 2.4.4.2.1. **by the agreement between Technical Service and manufacturer it shall be permissible to perform the test with all or parts of the electrical power train not being energized in so far as there is no negative influence on the test result. For parts of the electrical power train not energized, the protection against electrical shock shall be proved by either physical protection or isolation resistance and appropriate additional evidence.**
- 2.4.4.2.2. **in the case where an automatic disconnect is provided, at the request of the manufacturer it shall be permissible to perform the test with the automatic disconnect being triggered. In this case it shall be demonstrated that the automatic disconnect would have operated during the impact test. This includes the automatic activation signal as well as the galvanic separation considering the conditions as seen during the impact.”**

Paragraphs 2.4.4. and 2.4.5.(former), renumber as paragraphs 2.4.5. and 2.4.6, respectively.

Insert a new Annex 7 and Appendix 1, to read:

“Annex 7

Test Procedures for the Protection of the occupants of vehicles operating on electrical power ~~against~~ **from** high voltage and electrolyte spillage

This section describes test procedures to demonstrate compliance to the electrical safety requirements of paragraph 5.5. For example, megohmmeter or oscilloscope measurements are an appropriate alternative to the procedure described below for measuring isolation resistance. **In this case it may be necessary to deactivate the on-board isolation resistance monitoring system.**

~~The following procedures should be performed for each of the specified crash tests.~~

Before the vehicle **impact crash test conducted**, ~~measure and record~~ the high voltage bus voltage (Vb) (see figure 1) **shall be measured and recorded to and confirm** that it is within the operating voltage of the vehicle as ~~defined~~ **specified** by the **vehicle** manufacturer.

1. Test setup and equipment

If a high voltage disconnect function is used, measurements are **to be** taken from both sides of the device performing the disconnect function.

However, if the high voltage disconnect is integral to the RESS or the energy conversion system and the high-voltage bus of the RESS or the energy conversion system is protected according to ~~class protection IPXXB~~ **following the impact after crash test**, measurements may ~~be taken~~ **only be taken between the downstream of the device performing the disconnect function and the electrical loads.**

The voltmeter used in this test shall measure DC values and have an internal resistance of at least 10 MΩ.

~~Before the vehicle impact crash test, measure and record the high voltage bus voltage (Vb) (see figure 1) shall be measured and recorded to and confirm that it is within the operating voltage of the vehicle as defined specified by the vehicle manufacturer.~~

2. The following instructions may be used if voltage is measured.

After the **impact** ~~crash~~ test, determine the high voltage bus voltages (Vb, V1, V2) (see figure 1). ~~If the RESS has exposed conductive parts, measure the voltage V3 between any exposed conductive parts of it and the electrical chassis.~~

~~[The measurement shall be made at 5 seconds after the impact].~~

The voltage measurement shall be made not earlier than 5 seconds but not later than 60 seconds after the impact.

This procedure is not applicable if the test is performed under the condition where the electrical power train is not energized.

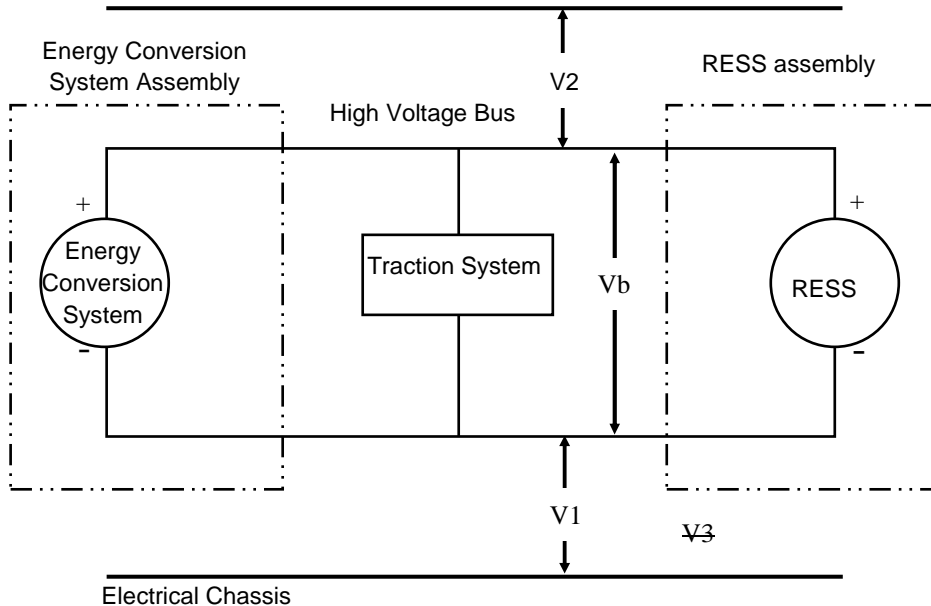

Figure 1: Measurement of Vb, V1, V2, V3

3. Assessment procedure for low electrical energy

Prior to the impact a switch S1 and a known discharge resistor Re is connected in parallel to the relevant capacitance (ref. figure 2) installed according to figure 2.

Not earlier than 5 seconds and not later than 60 seconds [At 5 seconds] after the impact the switch S1 shall be is-closed while the voltage Vb and the current Ie are is-measured and recorded. The product of the voltage Vb and the current Ie shall be is-integrated over the period of time, starting from the moment when the switch S1 is closed (tc) until the voltage Vb falls below the high voltage threshold of 30 V AC or 60 V DC (th). The resulting integration equals in-the total energy (TE) in joules:

$$(a) \quad TE = \int_{t_c}^{t_h} V_b \times I_e dt$$

When Vb is measured at a point in time between 5 seconds and 60 seconds after the impact and the capacitance of the X-capacitors (Cx) is specified by the manufacturer, total energy (TE) shall be calculated according to the following formula:

$$(b) \quad TE = 0.5 \times C_x \times (V_b^2 - 3\,600)$$

When V1, V2 (see figure 1) are measured at a point in time between 5 seconds and 60 seconds after the impact and the capacitances of the Y-capacitors (Cy1, Cy2) are specified by the manufacturer, total energy (TEy1, TEy2) shall be calculated according to the following formulas:

$$(c) \quad TE_{y1} = 0.5 \times C_{y1} \times (V_1^2 - 3\,600)$$

$$TE_{y2} = 0.5 \times C_{y2} \times (V_2^2 - 3\,600)$$

This procedure is not applicable if the test is performed under the condition where the electrical power train is not energized.

Figure 2
E.g. Measurement of high voltage bus energy stored in X-capacitors

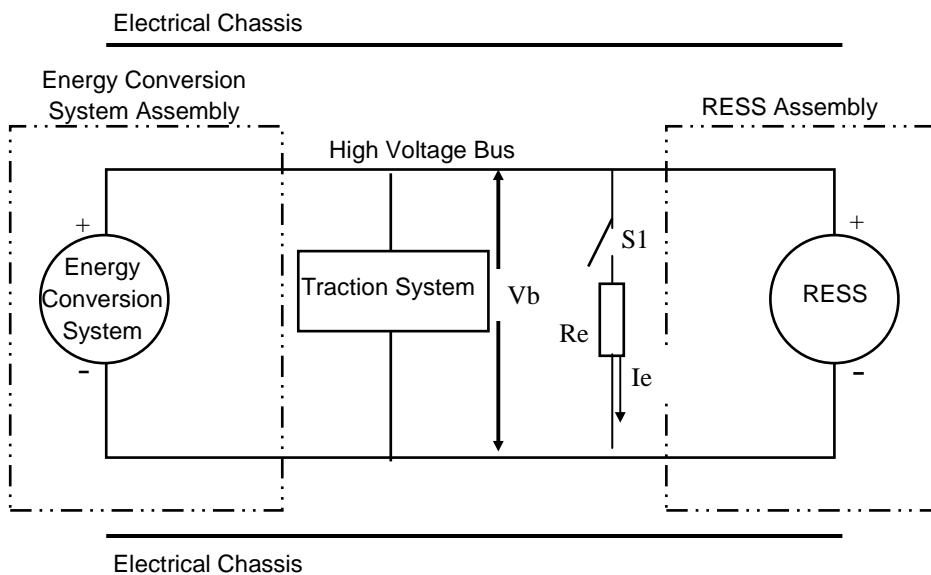

4. Physical protection

~~The manufacturer shall define the physical barriers, enclosures and solid insulators that protect the human from the direct contact with the high voltage bus in use (hereinafter referred to as the '[original] physical protection').~~

~~After crash~~ Following the vehicle impact test any ~~surrounding parts surrounding~~ of the high voltage components **shall be, without the use of tools, that can be** opened, disassembled or removed. ~~without the use of tools shall be opened, disassembled or removed. Only~~ **All remaining** surrounding parts that cannot be opened, disassembled or removed without the use of tools ~~are~~ **shall be** considered as a part of the ~~[original]~~ physical protection.

The **Jointed Test Finger** ~~access probe~~ described in Appendix 1 figure 1 is ~~pushed against~~ **shall be inserted into** any gaps or openings of the ~~[original]~~ physical protection with a ~~the~~ test force of $10\text{ N} \pm 10\text{ per cent}$ **for electrical safety assessment.** If **partial or full penetration** ~~it partly or fully penetrates~~ into the ~~[original]~~ physical protection **by the Jointed Test Finger** occurs, ~~it is the Jointed Test Finger shall be~~ placed in every possible position as specified below.

Starting from the straight position, both joints of the test finger shall be **rotated progressively** ~~successively bent~~ through an angle of up to 90 degrees with respect to the axis of the adjoining section of the finger and shall be placed in every possible position.

Internal barriers are considered part of the enclosure.

If appropriate a low-voltage supply (of not less than 40 V and not more than 50 V) in series with a suitable lamp should be connected, between the Jointed Test Finger and high voltage live parts inside the electrical protection barrier or enclosure.

4.1. Acceptance conditions

The **requirements of paragraph 5.5.1.3 shall be considered to be met if the Jointed Test Finger** ~~access probe~~ described in Appendix 1, figure 1 ~~shall not be~~ **unable to contact touch high voltage** live parts.

If necessary a ~~A~~ mirror or a fiberscope may be used in order to inspect whether the **Jointed Test Finger** touches the high voltage buses, ~~if necessary.~~

If this requirement is verified by a signal circuit between the Jointed Test Finger and high voltage live parts, the lamp shall not light.

5. Isolation resistance

The isolation resistance between the high voltage bus and the electrical chassis may be demonstrated either by measurement or by a combination of measurement and calculation.

The following instructions ~~should~~ **may** be used if **the** isolation resistance is **demonstrated** by measurement~~d~~.

~~[Before the vehicle crash test, measure and record the high voltage bus voltage (Vb) (see figure 1). Vb must be equal to or greater than the nominal operating voltage as defined by the vehicle manufacturer.]~~

~~[The vehicle manufacturer is allowed to calculate or simulate this value instead of measuring this after the crash.]~~

Measure and record the voltage (Vb) between the negative and the positive side of the high voltage bus (see figure 1):

Measure and record the voltage (V1) between the negative side of the high voltage bus and the electrical chassis (see figure 1):

Measure and record the voltage (V2) between the positive side of the high voltage bus and the electrical chassis (see figure 1):

If V1 is greater than or equal to V2, insert a standard known resistance (Ro) between the negative side of the high voltage bus and the electrical chassis. With Ro installed, measure the voltage (V1') between the negative side of the high voltage bus and the vehicle electrical chassis (see figure 3). Calculate the isolation resistance (Ri) according to the formula shown **below**.

$$R_i = R_o * (V_b / V1' - V_b / V1) \quad \text{or} \quad R_i = R_o * V_b * (1 / V1' - 1 / V1)$$

Divide **the result Ri, which is the** ~~this~~ electrical isolation resistance value in ohm (Ω) by the working voltage of the high voltage bus in volt (V) ~~in volts~~.

$$R_i (\Omega / V) = R_i (\Omega) / \text{Working voltage (V)}$$

~~$$R_i = R_o * (V_b / V1' - V_b / V1) \quad \text{or} \quad R_i = R_o * V_b * (1 / V1' - 1 / V1)$$~~

Figure 3
Measurement of V1'

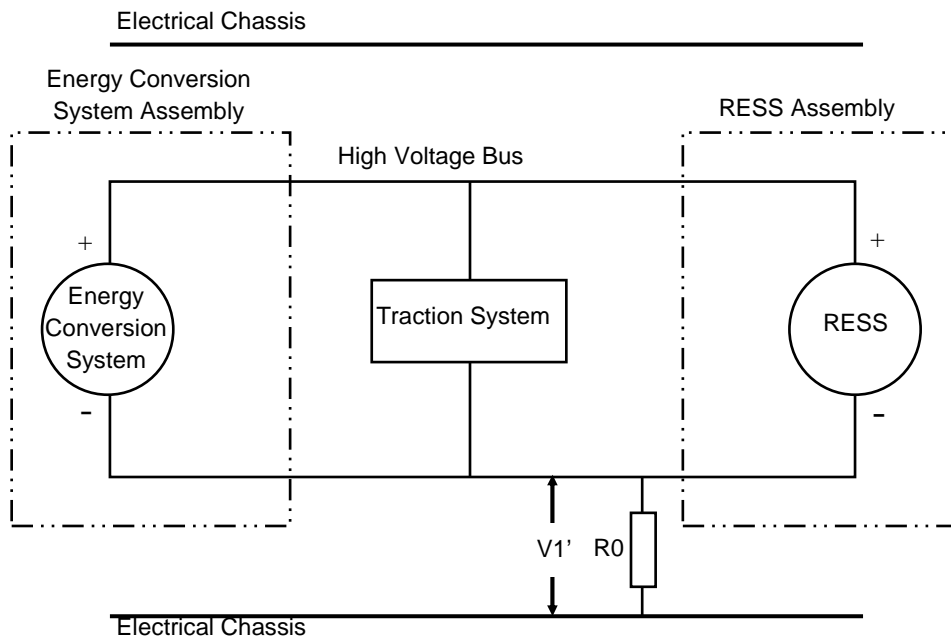

If V2 is greater than V1, insert a standard known resistance (Ro) between the positive side of the high voltage bus and the electrical chassis. With Ro installed, measure the voltage (V2') between the positive side of the high voltage bus and the electrical chassis (see figure 4).

Calculate the isolation resistance (Ri) according to the formula shown **below**. ~~Divide the result, which is the this~~ electrical isolation value (in Ω) by the ~~working voltage of the high voltage bus (in volts)~~.

$$R_i = R_o * (V_b / V2' - V_b / V2) \quad \text{or} \quad R_i = R_o * V_b * (1 / V2' - 1 / V2)$$

Divide the result R_i , which is the electrical isolation resistance value in ohm (Ω) by the working voltage of the high voltage bus in volt (V).

$$R_i (\Omega / V) = R_i (\Omega) / \text{Working voltage (V)}$$

Figure 4
Measurement of V_2'

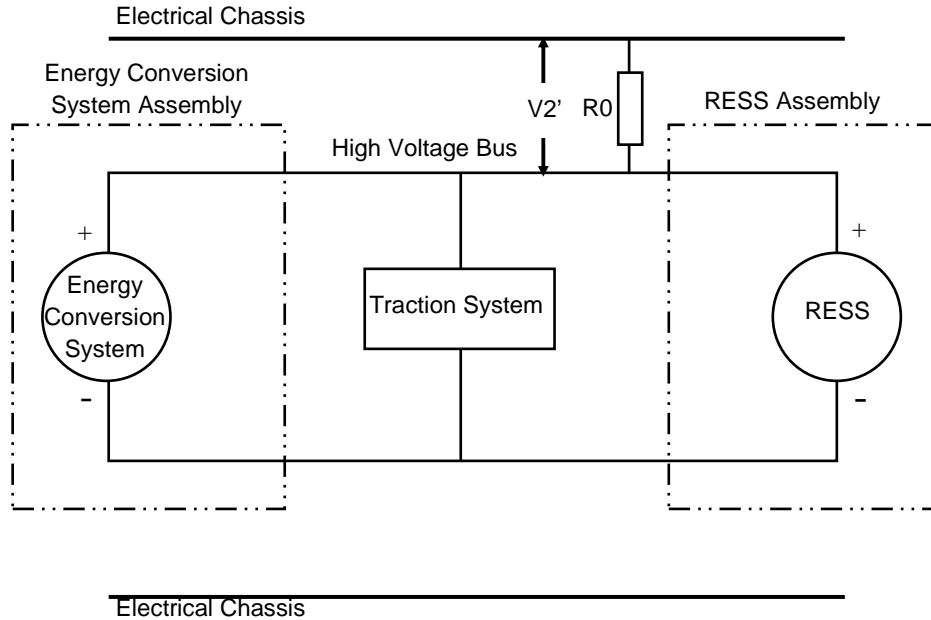

Note 1: The standard known resistance R_0 (Ω) should be approximately 500 times the working voltage of the vehicle the value of the minimum required isolation resistance (Ω/V) multiplied by the working voltage in volt (V) of the vehicle plus/minus 20 per cent in volts. R_0 is not required to be precisely this value since the equations are valid for any R_0 ; however, an R_0 value in this range should provide a good resolution for the voltage measurements.

The isolation resistance between the high voltage bus and the electrical chassis may be demonstrated by calculation, measurement or a combination of both.

6. Electrolyte spillage

Appropriate coating paint shall be applied, if necessary, to the physical protection in order to confirm the any electrolyte leakage is leaking from the RESS after the collision impact test.

Add color to other liquid (such as coolant, oil, fuel, etc.), if necessary, so that the electrolyte and other liquid can be classified or separated.

If the electrolyte cannot be clearly identified from the other leaking liquids, all liquid shall be considered as the electrolyte.

Unless the manufacturer provides means to differentiate between the leakage of different liquids, all liquid leakage shall be considered as the electrolyte.

7. RESS retention
Compliance shall be determined by visual inspection.

Appendix 1

Jointed test finger (IPXXB)

Protection against direct contacts of parts under voltage

1. Access probes

Access probes to verify the protection of persons against access to live parts are given in figure 1.

2. Test conditions

The access probe is pushed against any openings of the enclosure with the force specified in paragraph 4 of this annex. If it partly or fully penetrates, it is placed in every possible position, but in no case shall the stop face fully penetrate through the opening.

Internal barriers are considered part of the enclosure

A low voltage supply (of not less than 40 V and not more than 50 V) in series with a suitable lamp should be connected, if necessary, between the probe and live parts inside the barrier or enclosure.

The signal circuit method should also be applied to the moving live parts of high voltage equipment.

Internal moving parts may be operated slowly, where this is possible.

3. Acceptance conditions

The access probe shall not touch live parts.

If this requirement is verified by a signal circuit between the probe and live parts, the lamp shall not light.

In the case of the test for IPXXB, the jointed test finger may penetrate to its 80 mm length, but the stop face (diameter 50 mm x 20 mm) shall not pass through the opening. Starting from the straight position, both joints of the test finger shall be successively bent through an angle of up to 90 degree with respect to the axis of the adjoining section of the finger and shall be placed in every possible position.

Figure 1
Jointed test finger

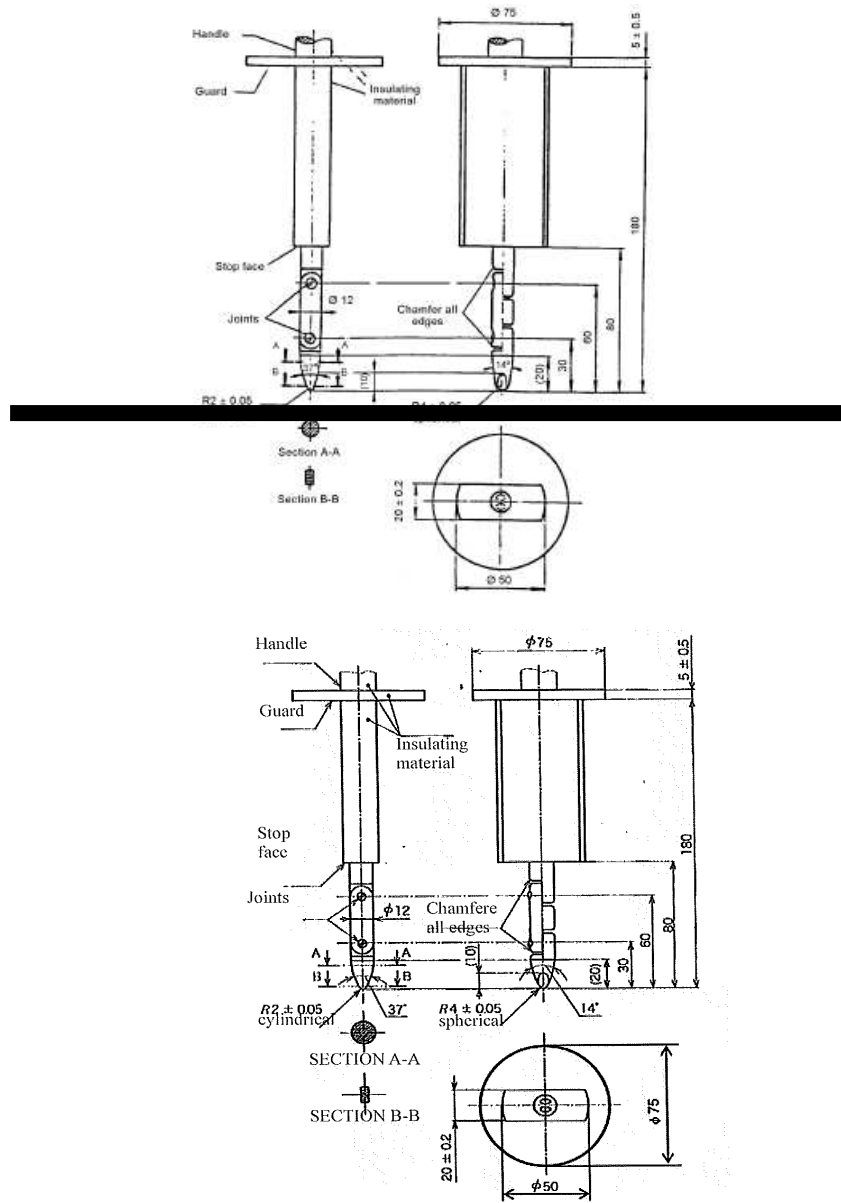

Material: metal, except where otherwise specified

Linear dimensions in millimeters

Tolerances on dimensions without specific tolerance:

- (a) on angles: 0/-10°
- (b) on linear dimensions: up to 25 mm: 0/-0.05 mm over 25 mm: ± 0.2 mm

Both joints shall permit movement in the same plane and the same direction through an angle of 90° with a 0 to +10° tolerance.”

Annex IV

Amendments to Regulation No. 16

Amendments adopted to ECE/TRANS/WP.29/GRSP/2010/11 (see para. 24 of the report)

Paragraph 6.2.2.2., amend to read:

“6.2.2.2. The buckle, even when not under tension,....The buckle release area shall be coloured red. No other part of the buckle shall be of this colour **when the seat is occupied**, red warning light in any part of the buckle is permitted if it is switched off after the occupant has buckled.”

Amendments adopted to ECE/TRANS/WP.29/GRSP/2010/18 (see para. 25 of the report)

...

Insert a new paragraph 15.2.23., to read:

“15.2.23. No Contracting Parties applying this Regulation shall refuse to grant ECE approvals **of a component** under a preceding series of amendments to the Regulation if the safety-belts are intended to be installed in vehicles which are approved before the respective series of amendment.”

Annex V

Amendments to Regulation No. 44

Amendments adopted to ECE/TRANS/WP.29/GRSP/2010/22 (see para. 31 of the report)

Paragraph 7.1.4.3.1., amend to read:

~~“7.1.4.3.1. During the verification... device. On the manikin representing a 10 years old child, abdominal penetration shall be assessed with first priority by video film analysis.”~~

Paragraph 8.1.3.6.3.3., amend to read:

“8.1.3.6.3.3. The longitudinal... paragraph 8.1.3.2.1.3. In case of child restraints to be tested with the manikin representing a 10-years-old child, the longitudinal plane passing through the centre line of the manikin shall be positioned up to **80** mm towards the side of anchorage point C with regard to the point midway between the two lower belt anchorages. The amount of this displacement shall be decided by the technical service in order to optimize the shoulder belt routing at the manikin.”

Paragraph 8.1.3.6.3.4., amend to read:

“8.1.3.6.3.4. In the case of devices requiring the use of a standard belt, the ~~optimal~~ routing of the shoulder strap may be maintained on the manikin prior to the dynamic test by the use of a light-weight masking tape of a maximum length of 250 mm and a maximum width of 20 mm. In the case of rearward facing devices the head may be held against the backrest of the restraint system using a light-weight masking tape of sufficient length and a maximum width of 20 mm.”

Annex VI

Amendments to Regulation No. 94

Amendments adopted to ECE/TRANS/WP.29/GRSP/2010/20
(see para. 35 of the report)

Contents, insert a new Annex 11, to read:

“... ”

Annex 11 - **Test Procedures for the Protection of the occupants of vehicles operating on electrical power from high voltage and electrolyte spillage.**

~~Appendix 1 – Protection against direct contacts of parts under voltage”~~

Appendix 1 – Jointed Test Finger (IPXXB)”

Paragraph 2.6.4., amend to read:

“2.6.4. **The siting (front, rear or centre) and the orientation (transversal or longitudinal) of the engine, in so far as they have a negative effect on the result of the impact test procedure as prescribed in this Regulation.”**

Insert new paragraph 2.6.7., to read:

“2.6.7. ~~{The place of the rechargeable energy storage system (RESS)}~~

The locations of the RESS, in so far as they have a negative effect on the result of the impact test prescribed in this Regulation,”

Paragraph 2.7., amend to read:

“2.7. **Passenger compartment”**

Insert a new paragraph 2.7.1., to read:

“2.7.1. **“Passenger compartment with regard to occupant protection”** means the space for occupant accommodation, bounded by the roof, floor, side walls, doors, outside glazing and front bulkhead and the plane of the rear compartment bulkhead or the plane of the rear-seat back support.” ~~For the sake of protection of occupants from high voltage and electrolyte spillage according to Annex 11 a different definition (see paragraph 2.32.) is applied.”~~

Insert a new paragraph 2.7.2., to read:

“2.7.2. **“Passenger compartment for electric safety assessment”** means the space for occupant accommodation, bounded by the roof, floor, side walls, doors, outside glazing, front bulkhead and rear bulkhead, or rear gate, as well as by the electrical protection barriers and enclosures provided for protecting the power train from direct contact with high voltage live parts.”

Insert new paragraphs 2.15. to 2.34., to read:

~~2.30.~~2.15. **“High Voltage”** means the classification of an electric component or circuit, if its working voltage is > 60 V and ≤ 1500 V **direct current (DC)** or > 30 V and ≤ 1000 V **alternating current (AC) root – mean – square (rms)**,

2.16. **“Rechargeable energy storage system (RESS)”** means the rechargeable energy storage system ~~that~~ **which** provides ~~the~~ electrical energy for propulsion,

- ~~2.28.2.17.~~ [~~“Electrical Protection Barrier” / Protection Shielding / Shielding / Barrier-
el/ High Voltage Protection~~] means the part providing protection against any direct contact to the **high voltage** live parts ~~from any direction of access,~~
- ~~2.15.2.18.~~ “*Electrical power train*” means the electrical circuit which includes the traction motor(s), and may **also** include the RESS, the electrical energy conversion system, the electronic converters, the associated wiring harness and connectors, and the coupling system for charging the RESS,
- ~~2.21.2.19.~~ “*Live parts*” means conductive part(s) intended to be electrically energized in normal use,
- ~~2.24.2.20.~~ “*Exposed conductive part*” means the conductive part which can be touched under the provisions of the protection ~~degree~~ IPXXB, and which becomes electrically energized under isolation failure conditions,
- ~~2.20.2.21.~~ “*Direct contact*” means the contact of persons with **high voltage** live parts,
- ~~2.22.2.22.~~ “*Indirect contact*” means the contact of persons with exposed conductive parts,
- ~~2.23.2.23.~~ “*Protection IPXXB degree*” means ~~the~~ protection **from contact with high voltage live parts** provided by **either an electrical protection barrier or an enclosure related to the contact with live parts by a test probe, such as a and tested using a Jointed Test Finger (IPXXB) or a test wire (IPXXD) as described** defined in Appendix 1 paragraph 4 of Annex 911,
- ~~2.26.2.24.~~ “*Working voltage*” means the highest value of an electrical circuit voltage root-mean-square (rms), specified by the manufacturer, which may occur between any conductive parts in open circuit conditions or under normal operating conditions. If the electrical circuit is divided by galvanic isolation, the working voltage is defined for each divided circuit, respectively.
- ~~2.19.2.25.~~ “*Coupling system for charging the rechargeable energy storage system (RESS)*” means the electrical circuit used for charging the RESS from an external electrical power supply including the vehicle inlet,
- ~~2.27.2.26.~~ “*Electrical chassis*” means a set made of conductive parts electrically linked together, whose **electrical** potential is taken as reference,
- ~~2.25.2.27.~~ “*Electrical circuit*” means an assembly of connected **high voltage** live parts which is designed to be electrically energized in normal operation,
- ~~2.17.2.28.~~ “*Electrical energy conversion system*” means a system (e.g. fuel cell) that generates and provides electrical energy for electrical propulsion,
- ~~2.18.2.29.~~ “*Electronic converter*” means a device capable of controlling and/or converting electrical power for electrical propulsion,
- ~~2.29.2.30.~~ “*Enclosure*” means the part enclosing the internal units and providing protection against **any** direct contact ~~from any direction of access,~~
- 2.31. “*High Voltage Bus*” means the electrical circuit, including the coupling system for charging the RESS that operates on a high voltage,
- ~~2.33.2.~~ “*Solid insulator*” means **the** insulating coating of wiring harnesses, provided in order to cover and **prevent** ~~protect~~ the **high voltage** live parts ~~against from any direct contact from any direction of access.~~ **This includes** covers for insulating the **high voltage** live parts of connectors; and varnish or paint for the purpose of insulation,

2.33. “Automatic disconnect” means a device that when triggered, galvanically separates the electrical energy sources from the rest of the high voltage circuit of the electrical power train,”

2.34. “Open type traction battery” means a type of battery requiring liquid and generating hydrogen gas released to the atmosphere.”

Insert a new paragraph 3.2.6., to read:

“3.2.6. A general description of the RESS—electrical power source type, and [location] and the electrical power train (e.g. hybrid, electric).”

Paragraph 5.2., amend to read:

“5.2. Specifications

The test...at the same time.

[**Additionally**, vehicles equipped with electric power train shall meet the requirements of paragraph 5.2.8. ~~in addition~~. This ~~can~~ ~~could~~ ~~be demonstrated~~ ~~in met~~ by a separate ~~crash~~ ~~impact~~ test at the request of the manufacturer **and after validation by the Technical Service, given—provided** that the electrical components do not influence the occupant protection performance of the vehicle type as defined in paragraphs 5.2.1. to 5.2.5. of this Regulation.] **In case of this condition the requirements of paragraph 5.2.8. shall be checked in accordance with the methods set out in Annex 3 to this Regulation, except paragraphs, 2., 5. and 6. in Annex 3. But a dummy corresponding to the specifications for Hybrid III 1/ fitted with a 45° ankle and meeting the specifications for its adjustment shall be installed in each of the front outboard seats.”**

Insert new paragraphs 5.2.8. to 5.2.8.3., to read:

“5.2.8. **Following the test conducted in accordance with the procedure defined in Annex 3 to this Regulation**, the electrical power train operating on high voltage, ~~and as well as~~ the high voltage components and systems, which are galvanically connected to the high voltage bus of the electric power train, shall meet the following requirements:

5.2.8.1. Protection against electrical shock

After the impact at least one of the ~~four following~~ criteria specified in paragraph 5.2.8.1.1. through paragraph 5.2.8.1.4.2. shall be met.

If the vehicle has an automatic disconnect function, **or device(s) that galvanically divide the electric power train circuit during driving condition**, at least one of the **following** criteria shall apply **to the disconnected circuit or** to each divided ~~portion~~ ~~circuit~~ individually after the disconnect function is activated.

However criteria defined in 5.2.8.1.4. shall not apply if more than a single potential of a part of the high voltage bus is not protected under the conditions of protection IPXXB.

In the case that the test is performed under the condition that part(s) of the high voltage system are not energized, the protection against electrical shock shall be proved by either 5.2.8.1.3. or 5.2.8.1.4. for the relevant part(s).

5.2.8.1.1. Absence of high voltage

The voltages **V_b, V1 and V2** of the high voltage buses shall be equal or less than 30 VAC or 60 VDC as **specified in Annex 11 paragraph 2.**

5.2.8.1.2. Low electrical ~~e~~Energy

The total energy-Energy (TE) on the high voltage buses shall be less than 2.0 joules when measured according to the test procedure as specified in paragraph 3 of Annex 11 with the fomula (a) . Alternatively the total energy (TE) may be calculated by the measured voltage V_b of the high voltage bus and the capacitance of the X-capacitors (C_x) specified by the manufacturer according to formula (b) of paragraph 3 of Annex 11

The energy stored in the Y-capacitors (TE_{y1}, TE_{y2}) shall also be less than 2.0 joules. This shall be calculated by measuring the voltages V1 and V2 of the high voltage buses and the electrical chassis, and the capacitance of the Y-capacitors specified by the manufacturer according to formula (c) of paragraph 3 of Annex 11.

5.2.8.1.3. Physical protection

For protection **against direct contact with-of high voltage** live parts, the protection ~~degree~~-IPXXB shall be provided.

In addition, **for protection against electrical shock which could arise from indirect contact**, the resistance between all exposed conductive parts and the electrical chassis shall be lower than 0.1 ohm when there is current flow of at least 0.2 ampere.

This requirement is satisfied if the galvanic connection has been ~~established~~ **made** by welding.

5.2.8.1.4. Isolation resistance

The criteria specified in the paragraphs 5.2.8.1.4.1. and 5.2.8.1.4.2. below shall be met.

The measurement shall be conducted in accordance with paragraph 5 of Annex 11.

5.2.8.1.4.1. Electrical power train consisting of separate DC- or AC-buses

If **the** AC high voltage buses and **the** DC high voltage buses are galvanically isolated from each other, isolation resistance between the high voltage bus and the electrical chassis (**R_i, as defined in paragraph 5 of Annex 11**) shall have a minimum value of 100 Ω/V of the working voltage for DC buses, and a minimum value of 500 Ω/V of the working voltage for AC buses.

5.2.8.1.4.2. Electrical power train consisting of combined DC- and AC-buses

If **the** AC high voltage buses and **the** DC high voltage buses are galvanically connected isolation resistance between the high voltage bus and the electrical chassis (**R_i, as defined in paragraph 5 of Annex 11**) shall have a minimum value of 500 Ω/V of the working voltage.

However, if the protection ~~degree~~-IPXXB is satisfied for all AC high voltage buses or the AC voltage is equal or less than 30 V after **the vehicle impact crash**, **the** isolation resistance between the high voltage bus and the electrical chassis (**R_i, as defined in paragraph 5 of Annex 11**) shall have a minimum value of 100 Ω/V of the working voltage.

5.2.8.2. Electrolyte spillage

In the period from the impact until 30 minutes after no electrolyte from the {RESS} shall spill into the passenger compartment, and no more than {7 per cent with a maximum of / 5.0 liters} of electrolyte shall spill from the {RESS} **except open type traction batteries outside the passenger compartment. For open type traction batteries no more than 7 per cent with a maximum of 5.0 liters shall spill outside the passenger compartment**

The manufacturer shall demonstrate compliance in accordance with paragraph 6 of Annex 11.

5.2.8.3. {RESS} retention

{RESS} located inside the passenger compartment shall remain in the location in which they are installed and {RESS} components shall remain inside {RESS} boundaries.

No part of any {RESS} that is located outside the passenger compartment **for electric safety assessment** shall enter the passenger compartment during **or after the impact test procedures.**

The manufacturer shall demonstrate compliance in accordance with paragraph 7 of Annex 11.”

Insert new paragraphs 11.4. to 11.8., to read:

- “**11.4.** As from the official date of entry into force of the 02 series of amendments, no Contracting Party applying this Regulation shall refuse to grant ECE approval under this Regulation as amended by the 02 series of amendments.
- 11.5.** As from [24] months after the entry into force, Contracting Parties applying this Regulation shall grant ECE approvals only to those types of vehicle which comply with the requirements of this Regulation as amended by the 02 series of amendments.
- Notwithstanding the above, Contracting Parties applying this Regulation may [continue to] grant ECE approvals to the 01 series of amendments for an additional [12] months provided that the manufacturer demonstrates, to the satisfaction of the Technical Service, that the vehicle provides equivalent levels of safety to those required by this Regulation as amended by the 02 series of amendments.
- 11.6.** As from the date of entry into force, Contracting Parties applying this Regulation shall not refuse to grant extensions to approvals issued to the preceding series of amendments to this Regulation. However, as from [24] months after the entry into force of the 02 series of amendments extensions to approvals issued to the previous series of amendments shall not be granted in respect of vehicles having an electrical power train operating on high voltage.
- 11.7.** By way of derogation to the obligations of Contracting Parties applying this Regulation, where at the time of entry into force of the 02 series of amendments to this Regulation national requirements exist to address the safety provisions detailed in these amendments, those Contracting Parties may continue to permit the entry into service of vehicles approved to the preceding series of amendments and complying with the specific national requirements applying at that time. This derogation shall cease to be valid [24] months after the entry into force of the 02 series of amendments to this Regulation.
- 11.8.** As from [48] months after the entry into force of the 02 series of amendments to this Regulation, Contracting Parties applying this Regulation may refuse national or regional type approval and may refuse first national or regional registration (first entry into service) of a vehicle having an electrical power train operating on high voltage which does not meet the requirements of the 02 series of amendments to this Regulation.]”

Annex 1, Communication, insert a new item 5.3., to read:

- “5.3. Location of the electrical power source

Annex 2, amend to read:

“Arrangements of the approval mark

Model A

(See paragraph 4.4. of this Regulation)

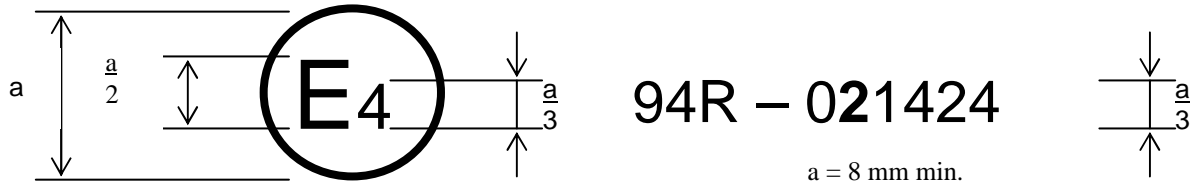

The above approval mark affixed to a vehicle shows that the vehicle type concerned has, with regard to the protection of the occupants in the event of a frontal collision, been approved in the Netherlands (E4) pursuant to Regulation No. 94 under approval number 021424. The approval number indicates that the approval was granted in accordance with the requirements of Regulation No. 94 as amended by the 02 series of amendments.

Model B

(See paragraph 4.5. of this Regulation)

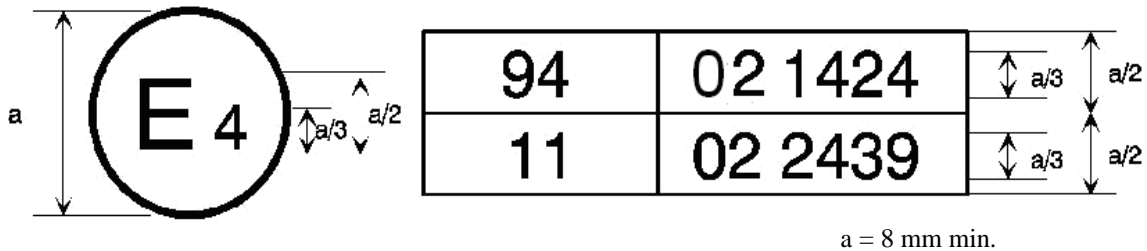

The above approval mark affixed to a vehicle shows that the vehicle type concerned has been approved in the Netherlands (E4) pursuant to Regulations Nos. 94 and 11.¹ The first two digits of the approval numbers indicate that, at the dates when the respective approvals were granted, Regulation No. 94 incorporated the 02 series of amendments and Regulation No. 11 incorporated the 02 series of amendments.”

Annex 3,

Paragraph 1.4.1., amend to read:

“1.4.1. General specification

The test vehicle...under paragraph 6.

At the request of the manufacturer it shall be allowed to perform the test with the engine or electric energy conversion system running and to allow for the fuel system to be modified in such a way that an appropriate amount of fuel can be used.

¹ The latter number is given only as an example.

It shall be allowed by agreement between manufacturer and Technical Service to modify the fuel system so that an appropriate amount of fuel can be used to run the engine or the electrical energy conversion system.”

Paragraph 1.4.2.2., amend to read:

“1.4.2.2. The fuel tank shall be filled with water to mass equal to 90 per cent of the **mass of a full load of fuel** as specified by the manufacturer with a tolerance of ± 1 per cent;

~~Alternative gas (i.e. helium gas) or alternative liquid (i.e. liquid nitrogen (LN₂)) can be used instead of hydrogen gas or liquid hydrogen.~~

~~However the requirement of paragraph 5.2.8.1.3. shall be satisfied for the hydrogen conversion system disconnected by its automatic disconnect when this alternative is used.”~~

This requirement does not apply to Hydrogen fuel tanks.”

Insert new paragraphs 1.4.4. to 1.4.4.2.2., to read:

“1.4.4. Electrical power train adjustment

1.4.4.1. The RESS shall be at any state of charge, which allows the normal operation of the power train as recommended by the manufacturer.

1.4.4.2. ~~[The high voltage system shall be energized.]~~ **The electrical power train shall be energized with or without the operation of the original electrical energy sources (e.g. engine-generator, RESS or electric energy conversion system), however:**

1.4.4.2.1. **by the agreement between Technical Service and manufacturer it shall be permissible to perform the test with all or parts of the electrical power train not being energized insofar as there is no negative influence on the test result. For parts of the electrical power train not energized, the protection against electrical shock shall be proved by either physical protection or isolation resistance and appropriate additional evidence.**

1.4.4.2.2. **in the case where an automatic disconnect is provided, at the request of the manufacturer it shall be permissible to perform the test with the automatic disconnect being triggered. In this case it shall be demonstrated that the automatic disconnect would have operated during the impact test. This includes the automatic activation signal as well as the galvanic separation considering the conditions as seen during the impact.”**

Insert a new Annex 11 and Appendix 1, to read:

“Annex 11

Test Procedures for the Protection of the occupants of vehicles operating on electrical power ~~against/ from~~ high voltage and electrolyte spillage

This section describes test procedures to demonstrate compliance to the electrical safety requirements of paragraph 5.2.8. For example, megohmmeter or oscilloscope measurements are an appropriate alternative to the procedure described below for measuring isolation resistance. **In this case it may be necessary to deactivate the on-board isolation resistance monitoring system.**

~~The following procedures should be performed for each of the specified crash tests.~~

Before the vehicle ~~impact-crash test conducted, measure and record~~ the high voltage bus voltage (Vb) (see figure 1) **shall be measured and recorded to** ~~and confirm that it is~~ within the operating voltage of the vehicle as ~~defined~~ **specified** by the vehicle manufacturer.

1. Test setup and equipment

If a high voltage disconnect function is used, measurements are **to be** taken from both sides of the device performing the disconnect function.

However, if the high voltage disconnect is integral to the RESS or the energy conversion system and the high-voltage bus of the RESS or the energy conversion system is protected according to **protection class IPXXB** ~~after following the impact-crash test, measurements may be taken only be taken between downstream of the device performing the disconnect function and electrical loads.~~

The voltmeter used in this test shall measure DC values and have an internal resistance of at least 10 MΩ.

~~Before the vehicle impact-crash test, measure and record the high voltage bus voltage (Vb) (see figure 1) shall be measured and recorded to and confirm that it is within the operating voltage of the vehicle as defined specified by the vehicle manufacturer.~~

2. The following instructions may be used if voltage is measured.

After the ~~impact-crash test, determine the high voltage bus voltages (Vb, V1, V2) (see figure 1). If the RESS has exposed conductive parts, measure the voltage V3 between any exposed conductive parts of it and the electrical chassis.~~

~~[The measurement shall be made at 5 seconds after the impact].~~

The voltage measurement shall be made not earlier than 5 seconds, but, not later than 60 seconds after the impact.

This procedure is not applicable if the test is performed under the condition where the electric power train is not energized.

Figure 1
Measurement of Vb, V1, V2, V3

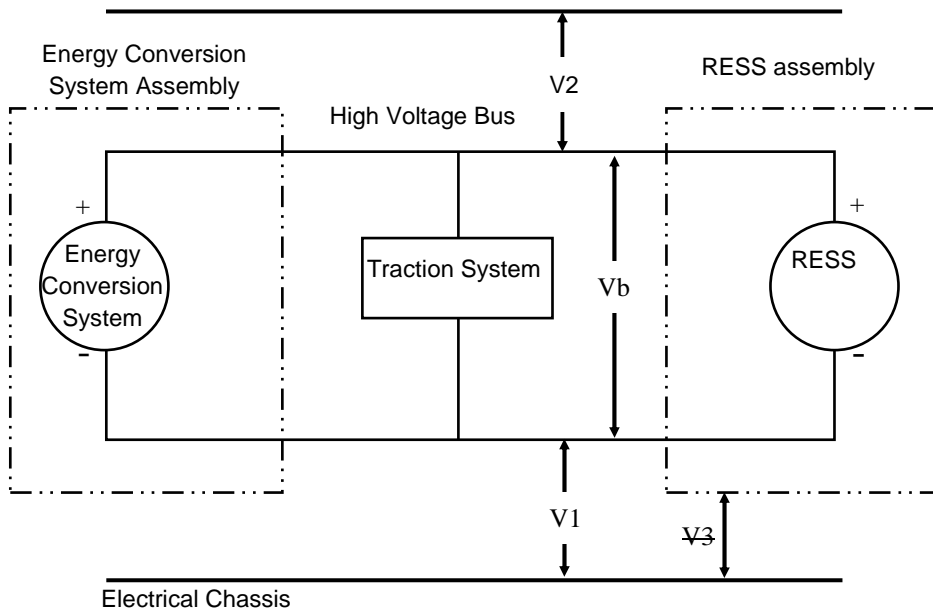

3. Assessment procedure for low electrical Energy

Prior to the impact a switch S1 and a known discharge resistor Re is **connected in parallel to the relevant capacitance (ref. figure 2)**, installed according to figure 2.

Not earlier than 5 seconds and not later than 60 seconds [At 5 seconds] after the impact the switch S1 ~~is~~ **shall be** closed while the voltage Vb and the current Ie ~~is~~ **are** measured and recorded. The product of the voltage Vb and the current Ie ~~is~~ **shall be** integrated over the period of time, starting from the moment when the switch S1 is closed (tc) until the voltage Vb falls below the high voltage threshold of 30 V AC or 60 V DC (th). ~~The resulting integration equals~~ **the total energy (TE) in joules.**

(a)
$$TE = \int_{t_c}^{t_h} V_b \times I_e dt$$

When Vb is measured at a point in time between 5 seconds and 60 seconds after the impact and the capacitance of the X-capacitors (Cx) is specified by the manufacturer, total energy (TE) shall be calculated according to the following formula:

(b)
$$TE = 0.5 \times C_x \times (V_b^2 - 3600)$$

When V1, V2 (see figure 1) are measured at a point in time between 5 seconds and 60 seconds after the impact and the capacitances of the Y-capacitors (Cy1, Cy2) are specified by the manufacturer, total energy (TEy1, TEy2) shall be calculated according to the following formulas:

(c)
$$TE_{y1} = 0.5 \times C_{y1} \times (V_1^2 - 3\ 600)$$

$$TE_{y2} = 0.5 \times C_{y2} \times (V_2^2 - 3\ 600)$$

This procedure is not applicable if the test is performed under the condition where the electric power train is not energized.

Figure 2
E.g. Measurement of high voltage bus energy stored in X-capacitors

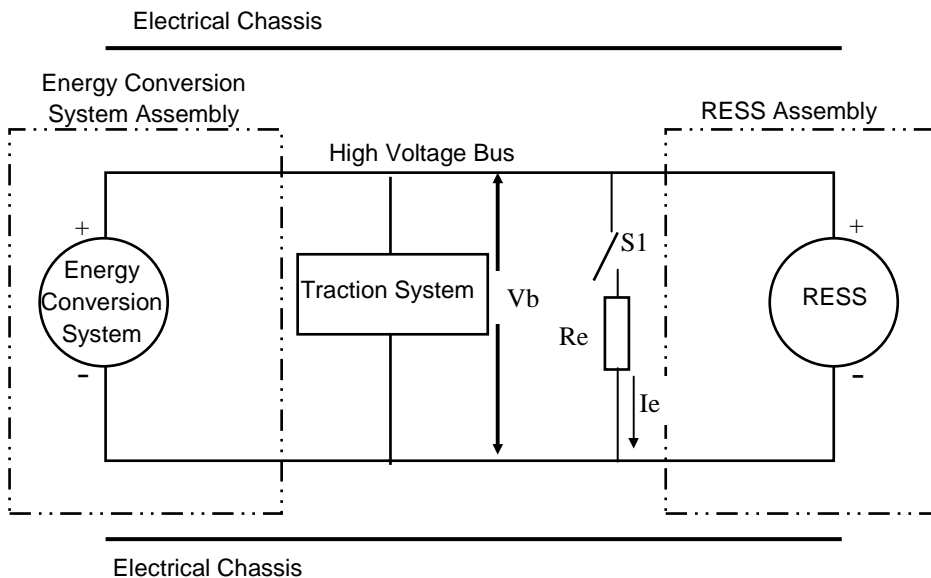

4. Physical Protection

~~The manufacturer shall define the physical barriers, enclosures and solid insulators that protect the human from the direct contact with the high voltage bus in use (hereinafter referred to as the '[original] physical protection').~~

~~After crash~~ **Following the vehicle impact test any surrounding parts surrounding** of the high voltage components **shall be, without the use of tools, that can be opened, disassembled or removed.** ~~without the use of tools shall be opened, disassembled or removed. Only All remaining~~ surrounding parts that cannot be opened, disassembled or removed without the use of tools **are shall be** considered as a part of the ~~[original]~~ physical protection.

The **Jointed Test Finger** ~~access probe~~ described in Appendix 1 figure 1 is ~~pushed against~~ **shall be inserted into** any **gaps or** openings of the ~~[original]~~ physical protection with ~~a the~~ test force of $10\text{ N} \pm 10$ per cent **for electrical safety assessment.** If **partial or full penetration** ~~it partly or fully penetrates~~ into the ~~[original]~~ physical protection by the **Jointed Test Finger** occurs, ~~it is the~~ **Jointed Test Finger shall be** placed in every possible position as **specified below.**

Starting from the straight position, both joints of the test finger shall be **rotated progressively** ~~successively bent~~ through an angle of up to 90 degrees with respect to the axis of the adjoining section of the finger and shall be placed in every possible position.

Internal electrical protection barriers are considered part of the enclosure

If appropriate a low-voltage supply (of not less than 40 V and not more than 50 V) in series with a suitable lamp should be connected, between the Jointed Test Finger and high voltage live parts inside the electrical protection barrier or enclosure.

4.1. Acceptance conditions

The requirements of paragraph 5.2.8.1.3. shall be considered to be met if the Jointed Test Finger ~~access-probe~~ described in Appendix 1, figure 1 ~~shall not~~ is unable to contact high voltage ~~touch~~ live parts.

If necessary ~~A~~ a mirror or a fiberscope may be used in order to inspect whether the ~~access-probe~~ Jointed Test Finger touches the high voltage buses, ~~if necessary~~.

If this requirement is verified by a signal circuit between the Jointed Test Finger and high voltage live parts, the lamp shall not light.

5. Isolation resistance

The isolation resistance between the high voltage bus and the electrical chassis may be demonstrated either by measurement or by a combination of measurement and calculation.

The following instructions ~~may~~ should be used if the isolation resistance is demonstrated by measurement.

~~[Before the vehicle crash test, measure and record the high voltage bus voltage (Vb) (see figure 1). Vb must be equal to or greater than the nominal operating voltage as defined by the vehicle manufacturer.]~~

~~[It is allowed to vehicle manufacturer to calculate or simulate this value instead of measuring this after the crash.]~~

Measure and record the voltage (Vb) between the negative and the positive side of the high voltage bus (see figure 1);

Measure and record the voltage (V1) between the negative side of the high voltage bus and the electrical chassis (see figure 1);

Measure and record the voltage (V2) between the positive side of the high voltage bus and the electrical chassis (see figure 1);

If V1 is greater than or equal to V2, insert a standard known resistance (Ro) between the negative side of the high voltage bus and the electrical chassis. With Ro installed, measure the voltage (V1') between the negative side of the high voltage bus and the vehicle electrical chassis (see figure 3). Calculate the isolation resistance (Ri) according to the formula shown below.

$$R_i = R_o * (V_b / V_1' - V_b / V_1) \quad \text{or} \quad R_i = R_o * V_b * (1 / V_1' - 1 / V_1)$$

Divide the result Ri, which is the ~~this~~ electrical isolation resistance value in ohm (Ω), by the working voltage of the high voltage bus ~~in volts~~ in volt (V).

$$R_i (\Omega / V) = R_i (\Omega) / \text{Working voltage (V)}$$

$$R_i = R_o * (V_b / V_1' - V_b / V_1) \quad \text{or} \quad R_i = R_o * V_b * (1 / V_1' - 1 / V_1)$$

Figure 3
Measurement of V'1

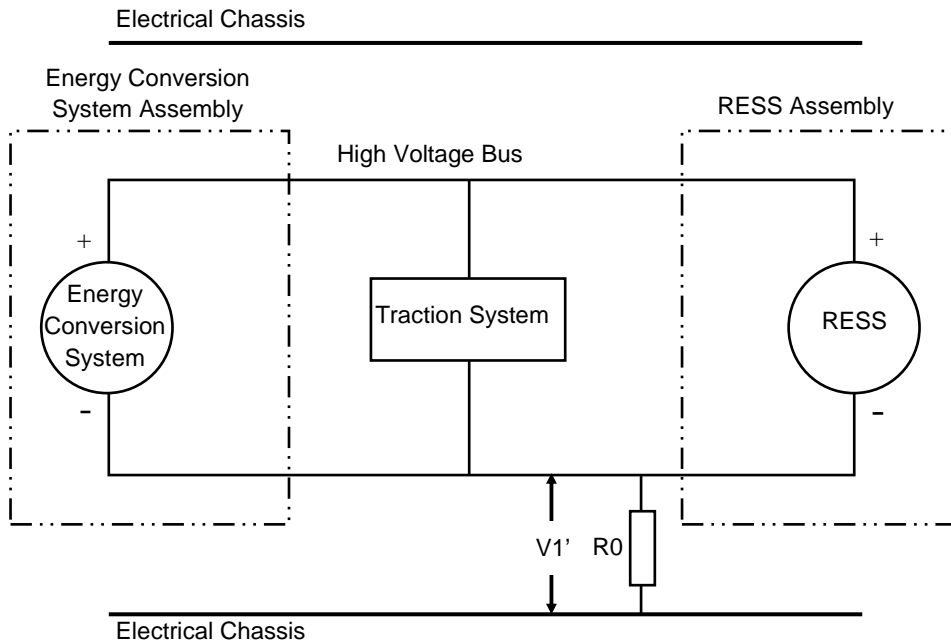

If V2 is greater than V1, insert a standard known resistance (R0) between the positive side of the high voltage bus and the electrical chassis. With R0 installed, measure the voltage (V2') between the positive side of the high voltage bus and the electrical chassis (see figure 4).

Calculate the isolation resistance (Ri) according to the formula shown below.

$$R_i = R_o * (V_b / V_2' - V_b / V_2) \quad \text{or} \quad R_i = R_o * V_b * (1 / V_2' - 1 / V_2)$$

Divide the result Ri, which is the this-electrical isolation resistance value in ohm (Ω), by the working voltage of the high voltage bus in volts in volt (V).

$$R_i (\Omega / V) = R_i (\Omega) / \text{Working voltage (V)}$$

~~$$R_i = R_o * (V_b / V_2' - V_b / V_2) \quad \text{or} \quad R_i = R_o * V_b * (1 / V_2' - 1 / V_2)$$~~

Figure 4
Measurement of V2'

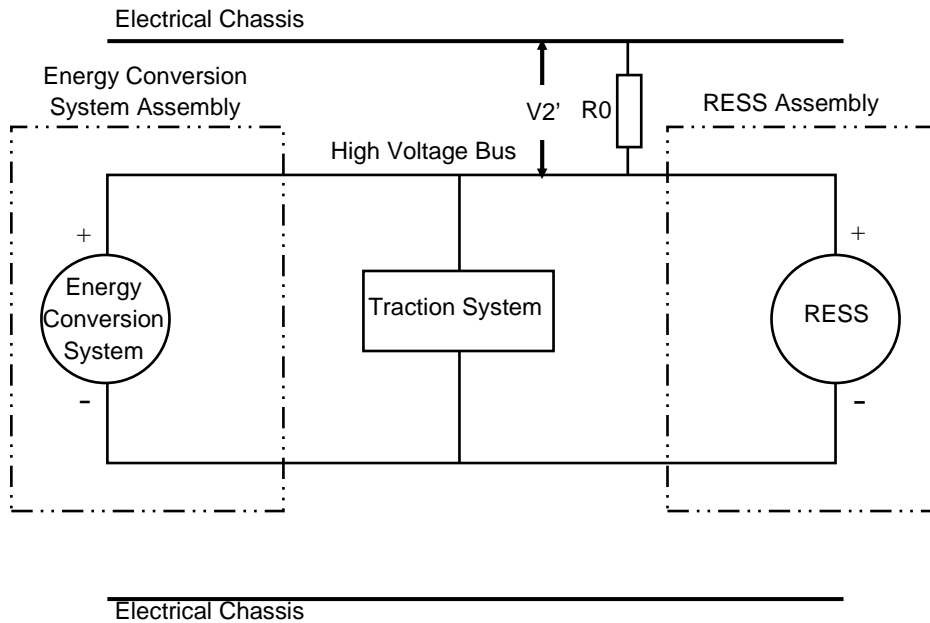

Note 1: The standard known resistance R_0 (in Ω) should be approximately 500 times the working voltage of the vehicle the value of the minimum required isolation resistance (in Ω/V) multiplied by the working voltage (in V) of the vehicle plus/minus 20 per cent in volts. R_0 is not required to be precisely this value since the equations are valid for any R_0 ; however, an R_0 value in this range should provide a good resolution for the voltage measurements.

The isolation resistance between the high voltage bus and the electrical chassis may be demonstrated by calculation, measurement or a combination of both.

6. Electrolyte spillage

Appropriate coating paint shall be applied, if necessary, to the [original] physical protection in order to confirm the any electrolyte leakage is leaking from the RESS after the impact test collision.

Add color to other liquid (such as coolant, oil, fuel, etc.), if necessary, so that the electrolyte and other liquid can be classified or separated.

If the electrolyte cannot be clearly identified from the other leaking liquids, all liquid shall be considered as the electrolyte.

Unless the manufacturer provides means to differentiate between the leakage of different liquids, all liquid leakage shall be considered as the electrolyte.

7. RESS retention

Compliance shall be determined by visual inspection

Appendix 1

Jointed test finger (IPXXB)

Protection against direct contacts of parts under voltage

1. Access probes

Access probes to verify the protection of persons against access to live parts are given in figure 1.

2. Test conditions

The access probe is pushed against any openings of the enclosure with the force specified in paragraph 4 of this annex. If it partly or fully penetrates, it is placed in every possible position, but in no case shall the stop face fully penetrate through the opening.

Internal barriers are considered part of the enclosure

A low voltage supply (of not less than 40 V and not more than 50 V) in series with a suitable lamp should be connected, if necessary, between the probe and live parts inside the barrier or enclosure.

The signal circuit method should also be applied to the moving live parts of high voltage equipment.

Internal moving parts may be operated slowly, where this is possible.

3. Acceptance conditions

The access probe shall not touch live parts.

If this requirement is verified by a signal circuit between the probe and live parts, the lamp shall not light.

In the case of the test for IPXXB, the jointed test finger may penetrate to its 80 mm length, but the stop face (diameter 50 mm x 20 mm) shall not pass through the opening. Starting from the straight position, both joints of the test finger shall be successively bent through an angle of up to 90 degree with respect to the axis of the adjoining section of the finger and shall be placed in every possible position.

Figure 1
Jointed test finger

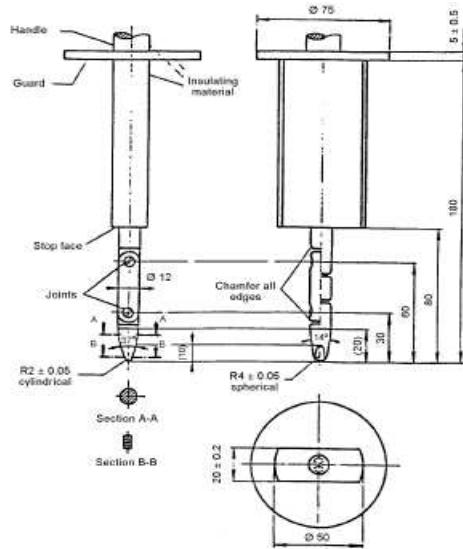

Material: metal, except where otherwise specified

Linear dimensions in millimeters

Tolerances on dimensions without specific tolerance:

- (a) on angles: 0/-10°
- (b) on linear dimensions: up to 25 mm: 0/-0.05 mm over 25 mm: ± 0.2 mm

Both joints shall permit movement in the same plane and the same direction through an angle of 90° with a 0 to +10° tolerance.”

Annex VII

Amendments to Regulation No. 95

Amendments adopted to ECE/TRANS/WP.29/GRSP/2010/21 (see para. 38 of the report)

Insert a new Annex 9, to read:

“... ”

Annex 9 - **Test Procedures for the Protection of the occupants of vehicles operating on electrical power from high voltage and electrolyte spillage.**

~~Appendix 1 – Protection against direct contacts of parts under voltage”~~

Appendix 1 – Jointed Test Finger (IPXXB)”

Paragraph 2.2.4., amend to read:

“2.2.4. **The siting of the engine (front, rear or centre) and the orientation (transversal or longitudinal) of the engine, in so far as they have a negative effect on the result of the impact test of this Regulation.”**

Insert new paragraph 2.2.8., to read

“2.2.8. ~~[The place of the rechargeable energy storage system (RESS)]”~~

The locations of the RESS, in so far as they have a negative effect on the result of the impact test prescribed in this Regulation,”

Paragraph 2.3., amend to read:

“2.3. Passenger compartment”

Insert a new paragraph 2.3.1., to read:

“2.3.1. *“Passenger compartment with regard to occupant protection”* means the space for occupant accommodation, bounded by the roof, floor, side walls, doors, outside glazing and front bulkhead and the plane of the rear compartment bulkhead or the plane of the rear-seat back support.” ~~For the sake of protection of occupants from high voltage and electrolyte spillage according to Annex 11 a different definition (see paragraph 2.32.) is applied.”~~

Insert a new paragraph 2.3.2., to read:

“2.3.2. *“Passenger compartment for electric safety assessment”* means the space for occupant accommodation, bounded by the roof, floor, side walls, doors, outside glazing, front bulkhead and rear bulkhead, or rear gate, as well as by the electrical protection barriers and enclosures provided for protecting the power train from direct contact with high voltage live parts.”

Insert new paragraphs 2.15. to 2.34., to read:

~~2.30.~~2.15. *“High Voltage”* means the classification of an electric component or circuit, if its working voltage is > 60 V and ≤ 1500 V **direct current** (DC) or > 30 V and ≤ 1000 V **alternating current** (AC) root – mean – square (rms),

2.16. *“Rechargeable energy storage system (RESS)”* means the rechargeable energy storage system ~~that~~ **which** provides ~~the~~ electrical energy for propulsion,

- ~~2.28.2.17.~~ [~~“Electrical Protection Barrier” / Protection Shielding / Shielding / Barrier-el / High Voltage Protection~~] means the part providing protection against **any** direct contact to the **high voltage** live parts ~~from any direction of access,~~
- ~~2.15.2.18.~~ “*Electrical power train*” means the electrical circuit which includes the traction motor(s), and may **also** include the RESS, the electrical energy conversion system, the electronic converters, the associated wiring harness and connectors, and the coupling system for charging the RESS,
- ~~2.21.2.19.~~ “*Live parts*” means conductive part(s) intended to be electrically energized in normal use,
- ~~2.24.2.20.~~ “*Exposed conductive part*” means the conductive part which can be touched under the provisions of the protection ~~degree~~ IPXXB, and which becomes electrically energized under isolation failure conditions,
- ~~2.20.2.21.~~ “*Direct contact*” means the contact of persons with **high voltage** live parts,
- ~~2.22.2.22.~~ “*Indirect contact*” means the contact of persons with exposed conductive parts,
- ~~2.23.2.23.~~ “*Protection IPXXB degree*” means ~~the~~ protection **from contact with high voltage live parts** provided by **either an electrical protection barrier or an enclosure related to the contact with live parts by a test probe, such as a and tested using a Jointed Test Finger (IPXXB) or a test wire (IPXXD) as described** defined in Appendix 1 paragraph 4 of Annex 9,
- ~~2.26.2.24.~~ “*Working voltage*” means the highest value of an electrical circuit voltage root-mean-square (rms), specified by the manufacturer, which may occur between any conductive parts in open circuit conditions or under normal operating conditions. If the electrical circuit is divided by galvanic isolation, the working voltage is defined for each divided circuit, respectively,
- ~~2.19.2.25.~~ “*Coupling system for charging the rechargeable energy storage system (RESS)*” means the electrical circuit used for charging the RESS from an external electrical power supply including the vehicle inlet,
- ~~2.27.2.26.~~ “*Electrical chassis*” means a set made of conductive parts electrically linked together, whose **electrical** potential is taken as reference,
- ~~2.25.2.27.~~ “*Electrical circuit*” means an assembly of connected **high voltage** live parts which is designed to be electrically energized in normal operation,
- ~~2.17.2.28.~~ “*Electrical energy conversion system*” means a system (e.g. fuel cell) that generates and provides electrical energy for electrical propulsion,
- ~~2.18.2.29.~~ “*Electronic converter*” means a device capable of controlling and/or converting electrical power for electrical propulsion,
- ~~2.29.2.30.~~ “*Enclosure*” means the part enclosing the internal units and providing protection against **any** direct contact ~~from any direction of access,~~
- 2.31. “*High Voltage Bus*” means the electrical circuit, including the coupling system for charging the RESS that operates on a high voltage,
- ~~2.33.2.~~ “*Solid insulator*” means **the** insulating coating of wiring harnesses, provided in order to cover and prevent ~~protect~~ the **high voltage** live parts ~~against~~ **any** direct contact ~~from any direction of access.~~ **This includes** covers for insulating the **high voltage** live parts of connectors; and varnish or paint for the purpose of insulation,

2.33. **“Automatic disconnect”** means a device that when triggered, galvanically separates the electrical energy sources from the rest of the high voltage circuit of the electrical power train,

2.34. **“Open type traction battery”** means a type of battery requiring liquid and generating hydrogen gas released to the atmosphere.”

Insert a new paragraph 3.2.6., to read:

“3.2.6. **A general** ~~General~~ description of the ~~RESS~~ **electrical power source** type, ~~and [location]~~ and the electrical power train (e.g. hybrid, electric).”

Paragraph 5.2., amend to read:

“5.2. Performance criteria

~~{~~**Additionally**, vehicles equipped with electric power train shall meet the requirements of paragraph 5.3.6. ~~in addition~~. This ~~can~~ ~~could~~ ~~be demonstrated~~ ~~in met by~~ a separate ~~crash impact~~ test at the request of the manufacturer **and after validation by the Technical Service, given provided** that the electrical components do not influence the occupant protection performance of the vehicle type as defined in paragraphs 5.2.1. to 5.3.4. of this Regulation. **In case of this condition the requirements of paragraph 5.3.6. shall be checked in accordance with the methods set out in Annex 4 to this Regulation, except paragraphs 6, 7 and Appendix 1 and 2. But the side-impact dummy shall be installed in the front seat on the impact side.**”

Insert new paragraphs 5.3.6. to 5.3.6.3., to read:

“5.3.6. **Following the test conducted in accordance with the procedure defined in Annex 4 to this Regulation**, the electrical power train operating on high voltage, ~~and as well as~~ the high voltage components and systems, which are galvanically connected to the high voltage bus of the electric power train, shall meet the following requirements:

5.3.6.1. Protection against electrical shock

After the impact at least one of the ~~four following~~ criteria specified in paragraph 5.3.6.1.1. through paragraph 5.3.6.1.4.2. shall be met.

If the vehicle has an automatic disconnect function, **or device(s) that galvanically divide the electric power train circuit during driving condition**, at least one of the **following** criteria shall apply **to the disconnected circuit or** to each divided ~~portion~~ ~~circuit~~ individually after the disconnect function is activated.

However criteria defined in 5.3.6.1.4. shall not apply if more than a single potential of a part of the high voltage bus is not protected under the conditions of protection IPXXB.

In the case that the test is performed under the condition that part(s) of the high voltage system are not energized, the protection against electrical shock shall be proved by either 5.3.6.1.3. or 5.3.6.1.4. for the relevant part(s).

5.3.6.1.1. Absence of high voltage

The voltages **V_b, V₁ and V₂** of the high voltage buses shall be equal or less than 30 VAC or 60 VDC **as specified in paragraph 2 of Annex 9.**

5.3.6.1.2. **Low electrical energy**

The total energy-Energy (TE) on the high voltage buses shall be less than 2.0 joules when measured according to the test procedure as specified in paragraph 3 of Annex 9 with the formula (a) . Alternatively the total energy (TE) may be calculated by the measured voltage V_b of the high voltage bus and the capacitance of the X-capacitors (C_x) specified by the manufacturer according to formula (b) of paragraph 3 of Annex 9

The energy stored in the Y-capacitors (TE_{y1} , TE_{y2}) shall also be less than 2.0 joules. This shall be calculated by measuring the voltages V_1 and V_2 of the high voltage buses and the electrical chassis, and the capacitance of the Y-capacitors specified by the manufacturer according to formula (c) of paragraph 3 of Annex 9

5.3.6.1.3. Physical protection

For protection **against direct contact with ~~of~~ high voltage** live parts, the protection ~~degree~~-IPXXB shall be provided.

In addition, **for protection against electrical shock which could arise from indirect contact**, the resistance between all exposed conductive parts and the electrical chassis shall be lower than 0.1 ohm when there is current flow of at least 0.2 ampere.

This requirement is satisfied if the galvanic connection has been ~~established~~ **made** by welding.

5.3.6.1.4. Isolation resistance

The criteria specified in the paragraphs 5.3.6.1.4.1. and 5.3.6.1.4.2. below shall be met.

The measurement shall be conducted in accordance with paragraph 5 of Annex 9.

5.3.6.1.4.1. Electrical power train consisting of separate DC- or AC-buses.

If **the** AC high voltage buses and **the** DC high voltage buses are galvanically isolated from each other, isolation resistance between the high voltage bus and the electrical chassis (**R_i, as defined in paragraph 5 of Annex 9**) shall have a minimum value of 100 Ω/V of the working voltage for DC buses, and a minimum value of 500 Ω/V of the working voltage for AC buses.

5.3.6.1.4.2. Electrical power train consisting of combined DC- and AC-buses

If **the** AC high voltage buses and **the** DC high voltage buses are galvanically connected isolation resistance between the high voltage bus and the electrical chassis (**R_i, as defined in paragraph 5 of Annex 9**) shall have a minimum value of 500 Ω/V of the working voltage.

However, if the protection ~~degree~~-IPXXB is satisfied for all AC high voltage buses or the AC voltage is equal or less than 30 V after **the vehicle impact crash**, **the** isolation resistance between the high voltage bus and the electrical chassis (**R_i, as defined in paragraph 5 of Annex 9**) shall have a minimum value of 100 Ω/V of the working voltage.

5.3.6.2. **Electrolyte spillage**

In the period from the impact until 30 minutes after no electrolyte from the {PRESS} shall spill into the passenger compartment, and no more than {7 per cent with a maximum of / 5.0 liters} of electrolyte shall spill from the {PRESS} **except open type traction batteries outside the passenger compartment.**

For open type traction batteries no more than 7 per cent with a maximum of 5.0 liters shall spill outside the passenger compartment

The manufacturer shall demonstrate compliance in accordance with paragraph 6 of Annex 9 .

5.3.6.3. {RESS} retention

{RESS} located inside the passenger compartment shall remain in the location in which they are installed and {RESS} components shall remain inside {RESS} boundaries.

No part of any {RESS} that is located outside the passenger compartment **for electric safety assessment** shall enter the passenger compartment during or after the **impact** test ~~procedures~~.

The manufacturer shall demonstrate compliance in accordance with paragraph 7 of Annex 9.”

Insert new paragraphs 10.6. to 10.10., to read:

“**10.6. As from the official date of entry into force of the 03 series of amendments, no Contracting Party applying this Regulation shall refuse to grant ECE approval under this Regulation as amended by the 03 series of amendments.**

10.7. As from [24] months after the entry into force, Contracting Parties applying this Regulation shall grant ECE approvals only to those types of vehicle which comply with the requirements of this Regulation as amended by the 03 series of amendments.

Notwithstanding the above, Contracting Parties applying this Regulation may [continue to] grant ECE approvals for an additional [12] months provided that the manufacturer demonstrates, to the satisfaction of the Technical Service, that the vehicle provides equivalent levels of safety to those required by this Regulation as amended by the 03 series of amendments.

10.8. As from [24] months after the date of entry into force, Contracting Parties applying this Regulation shall not refuse to grant extensions to approvals issued to the preceding series of amendments to this Regulation. However, extensions to approvals issued to the previous series of amendments shall not be granted after this date in respect of vehicles having an electrical power train operating on high voltage.

10.9. By way of derogation to the obligations of Contracting Parties applying this Regulation, where at the time of entry into force of the 03 series of amendments to this Regulation national requirements exist to address the safety provisions detailed in these amendments, those Contracting Parties may continue to permit the entry into service of vehicles approved to the preceding series of amendments and complying with the specific national requirements applying at that time. This derogation shall cease to be valid [24] months after the entry into force of the 03 series of amendments to this Regulation.

10.10. As from [48] months after the entry into force of the 04 series of amendments to this Regulation, Contracting Parties applying this Regulation may refuse national or regional type approval and may refuse first national or regional registration (first entry into service) of a

vehicle having an electrical power train operating on high voltage which does not meet the requirements of the 04 series of amendments to this Regulation.]”

Annex 1, Communication, insert a new item 7 to read:

“7. Location of the electric power source.....”

Item 7 to 15 (former), renumber as paragraphs 8 to 16.

Annex 2, amend to read:

“Arrangements of the approval mark

Model A

(See paragraph 4.5. of this Regulation)

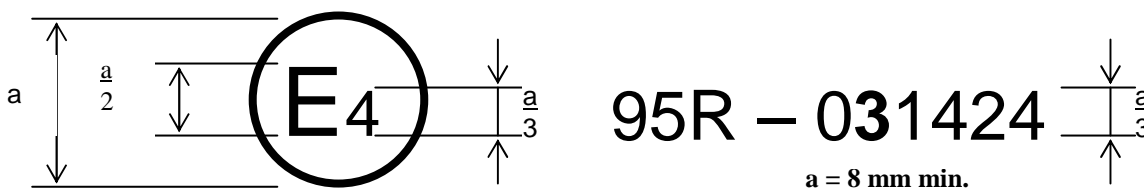

The above approval mark affixed to a vehicle shows that the vehicle type concerned has, with regard to the protection of the occupants in the event of a frontal collision, been approved in the Netherlands (E4) pursuant to Regulation No. 95 under approval number 031424. The approval number indicates that the approval was granted in accordance with the requirements of Regulation No. 95 as amended by the 03 series of amendments.

Model B

(See paragraph 4.6. of this Regulation)

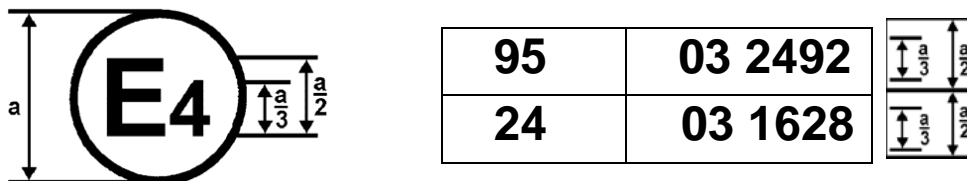

a = 8 mm min.

The above approval mark affixed to a vehicle shows that the vehicle type concerned has been approved in the Netherlands (E4) pursuant to Regulations Nos. 95 and 24.¹ The first two digits of the approval numbers indicate that, at the dates when the respective approvals were granted, Regulation No. 95 incorporated the 03 series of amendments and Regulation No. 24 incorporated the 03 series of amendments.”

Annex 4,

Paragraph 4.1., amend to read:

“4.1. General specification

The test vehicle ... of the test.

~~At the request of the manufacturer it shall be allowed to perform the test with the engine or electric energy conversion system running and to allow for the fuel system to be modified in such a way that an appropriate amount of fuel can be used.~~

It shall be allowed by agreement between manufacturer and Technical Service to modify the fuel system so that an appropriate amount of fuel can be used to run the engine or the electrical energy conversion system.”

Paragraph 4.3.2., amend to read:

“4.3.2. The fuel tank shall be filled with water to a mass equal to 90 per cent of the mass of a full load of fuel as specified by the manufacturer **with a tolerance of ± 1 per cent.**

~~Alternative gas (i.e. helium gas) or alternative liquid (i.e. liquid nitrogen (LN₂)) can be used instead of hydrogen gas or liquid hydrogen.~~

~~However the requirement of paragraph 5.2.8.1.3. shall be satisfied for the hydrogen conversion system disconnected by its automatic disconnect when this alternative is used.~~

This requirement does not apply to Hydrogen fuel tanks.”

¹ The latter number is given only as an example.

Insert new paragraphs 5.11. to 5.11.2.2., to read:

- “5.11. Electrical power train adjustment
- 5.11.1. The RESS shall be at any state of charge, which allows the normal operation of the power train as recommended by the manufacturer.
- 5.11.2. ~~[The high voltage system shall be energized.]~~**The electrical power train shall be energized with or without the operation of the original electrical energy sources (e.g. engine-generator, RESS or electric energy conversion system), however:**
- 5.11.2.1. **by the agreement between Technical Service and manufacturer it shall be permissible to perform the test with all or parts of the electrical power train not being energized insofar as there is no negative influence on the test result. For parts of the electrical power train not energized, the protection against electrical shock shall be proved by either physical protection or isolation resistance and appropriate additional evidence.**
- 5.11.2.2. **in the case where an automatic disconnect is provided, at the request of the manufacturer it shall be permissible to perform the test with the automatic disconnect being triggered. In this case it shall be demonstrated that the automatic disconnect would have operated during the impact test. This includes the automatic activation signal as well as the galvanic separation considering the conditions as seen during the impact.”**

Insert a new Annex 9 and Appendix 1, to read:

“Annex 9

Test Procedures for the Protection of the occupants of vehicles operating on electrical power ~~against/ from~~ high voltage and electrolyte spillage

This section describes test procedures to demonstrate compliance to the electrical safety requirements of paragraph 5.2.8. For example, megohmmeter or oscilloscope measurements are an appropriate alternative to the procedure described below for measuring isolation resistance. **In this case it may be necessary to deactivate the on-board isolation resistance monitoring system.**

~~The following procedures should be performed for each of the specified crash tests.~~

Before the vehicle ~~impact-crash test conducted, measure and record~~ the high voltage bus voltage (Vb) (see figure 1) **shall be measured and recorded to and confirm** that it is within the operating voltage of the vehicle as ~~defined—specified~~ by the vehicle manufacturer.

1. Test setup and equipment

If a high voltage disconnect function is used, measurements are **to be** taken from both sides of the device performing the disconnect function.

However, if the high voltage disconnect is integral to the RESS or the energy conversion system and the high-voltage bus of the RESS or the energy conversion system is protected according to **protection class IPXXB after following the impact-crash test, measurements may be taken only be taken between downstream** ~~of~~ the device performing the disconnect function **and electrical loads.**

The voltmeter used in this test shall measure DC values and have an internal resistance of at least 10 MΩ.

~~Before the vehicle impact crash test, measure and record the high voltage bus voltage (Vb) (see figure 1) shall be measured and recorded to and confirm that it is within the operating voltage of the vehicle as defined specified by the vehicle manufacturer.~~

- The following instructions may be used if voltage is measured.

After the **impact** crash test, determine the high voltage bus voltages (Vb, V1, V2) (see figure 1). ~~If the RESS has exposed conductive parts, measure the voltage V3 between any exposed conductive parts of it and the electrical chassis.~~

~~The measurement shall be made at 5 seconds after the impact.~~

The voltage measurement shall be made not earlier than 5 seconds, but, not later than 60 seconds after the impact.

This procedure is not applicable if the test is performed under the condition where the electric power train is not energized.

Figure 1
Measurement of Vb, V1, V2V3

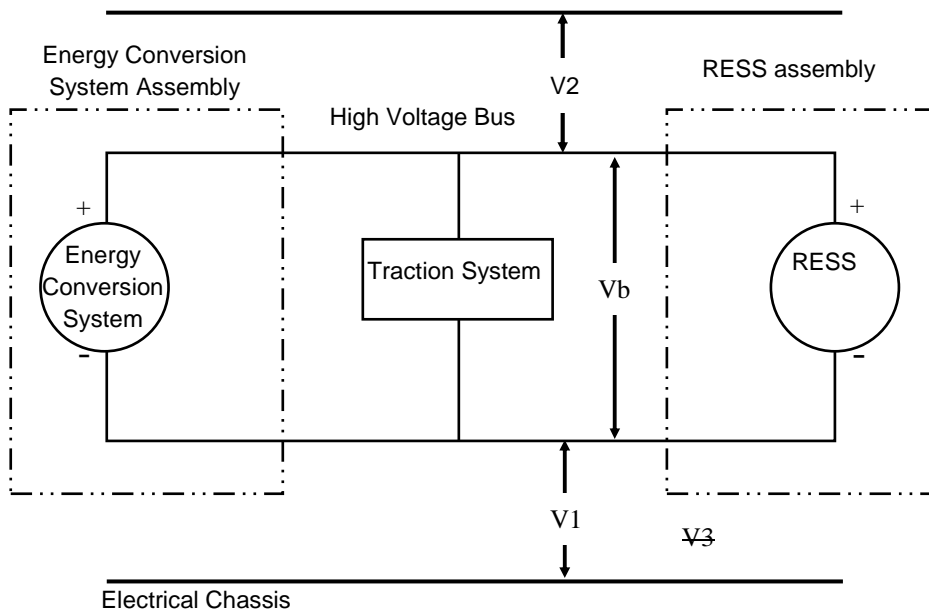

- Assessment procedure for low electrical Energy

Prior to the impact a switch S1 and a known discharge resistor R_e **is connected in parallel to the relevant capacitance (ref. figure 2)**, installed according to figure 2.

Not earlier than 5 seconds and not later than 60 seconds ~~[At 5 seconds]~~ after the impact the switch S1 ~~is~~ **shall be** closed while the voltage Vb and the current I_e ~~is~~ **are** measured and recorded. The product of the voltage Vb and the current I_e ~~is~~ **shall be** integrated over the period of time, starting from the moment when the switch S1

is closed (t_c) until the voltage V_b falls below the high voltage threshold of 30 V AC or 60 V DC (t_h). The resulting integration equals the total energy (TE) in joules.

$$(a) \quad TE = \int_{t_c}^{t_h} V_b \times I_e dt$$

When V_b is measured at a point in time between 5 seconds and 60 seconds after the impact and the capacitance of the X-capacitors (C_x) is specified by the manufacturer, total energy (TE) shall be calculated according to the following formula:

$$(b) \quad TE = 0.5 \times C_x \times (V_b^2 - 3600)$$

When V_1, V_2 (see figure 1) are measured at a point in time between 5 seconds and 60 seconds after the impact and the capacitances of the Y-capacitors (C_{y1}, C_{y2}) are specified by the manufacturer, total energy (TE_{y1}, TE_{y2}) shall be calculated according to the following formulas:

$$(c) \quad TE_{y1} = 0.5 \times C_{y1} \times (V_1^2 - 3600)$$

$$TE_{y2} = 0.5 \times C_{y2} \times (V_2^2 - 3600)$$

This procedure is not applicable if the test is performed under the condition where the electric power train is not energized.

Figure 2

E.g. Measurement of high voltage bus energy stored in X-capacitors

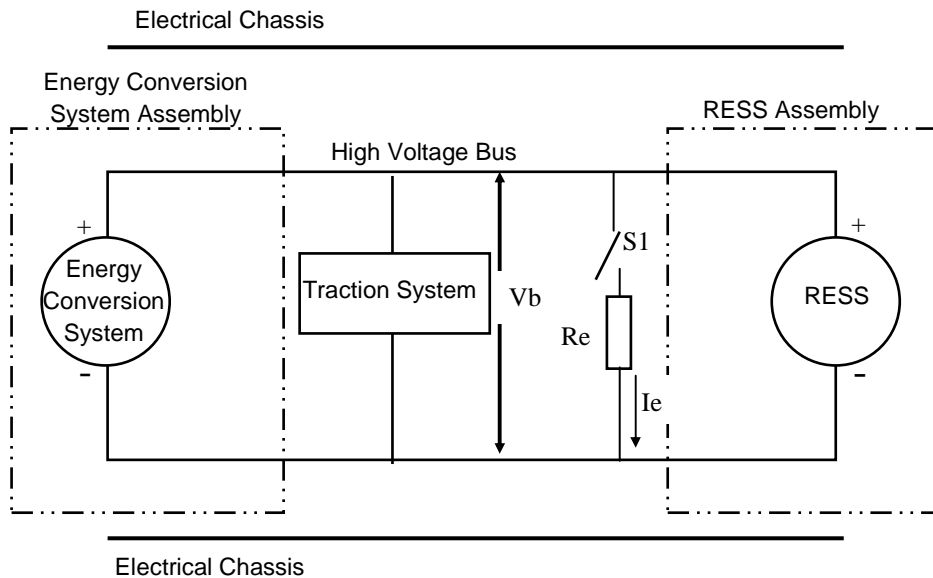

4. Physical Protection

The manufacturer shall define the physical barriers, enclosures and solid insulators that protect the human from the direct contact with the high voltage bus in use (hereinafter referred to as the '[original] physical protection').

After crash Following the vehicle impact test any surrounding parts surrounding of the high voltage components shall be, without the use of tools, that can be

~~opened, disassembled or removed. without the use of tools shall be opened, disassembled or removed. Only~~ **All remaining** surrounding parts that cannot be opened, disassembled or removed without the use of tools ~~are~~ **shall be** considered as a part of the ~~[original]~~ physical protection.

The **Jointed Test Finger** ~~access probe~~ described in Appendix 1 figure 1 ~~is pushed against~~ **shall be inserted into** any gaps or openings of the ~~[original]~~ physical protection with a ~~the~~ test force of $10\text{ N} \pm 10$ per cent **for electrical safety assessment**. If **partial or full penetration** ~~it partly or fully penetrates~~ into the ~~[original]~~ physical protection **by the Jointed Test Finger** occurs, ~~it is the~~ **Jointed Test Finger shall be** placed in every possible position as **specified below**.

Starting from the straight position, both joints of the test finger shall be **rotated progressively** ~~successively bent~~ through an angle of up to 90 degrees with respect to the axis of the adjoining section of the finger and shall be placed in every possible position.

Internal electrical protection barriers are considered part of the enclosure.

If appropriate a low-voltage supply (of not less than 40 V and not more than 50 V) in series with a suitable lamp should be connected, between the Jointed Test Finger and high voltage live parts inside the electrical protection barrier or enclosure.

4.1. Acceptance conditions

The **requirements of paragraph 5.3.6.1.3. shall be considered to be met if the Jointed Test Finger** ~~access probe~~ described in Appendix 1, figure 1 ~~shall not~~ **is unable to contact high voltage** ~~touch~~ live parts.

~~If necessary~~ **A** mirror or a fiberscope may be used in order to inspect whether the ~~access probe~~ **Jointed Test Finger** touches the high voltage buses, ~~if necessary~~.

If this requirement is verified by a signal circuit between the Jointed Test Finger and high voltage live parts, the lamp shall not light.

5. Isolation resistance

The isolation resistance between the high voltage bus and the electrical chassis may be demonstrated either by measurement or by a combination of measurement and calculation.

The following instructions ~~may~~ **should** be used if ~~the~~ isolation resistance is **demonstrated by measurement**.

~~[Before the vehicle crash test, measure and record the high voltage bus voltage (Vb) (see figure 1). Vb must be equal to or greater than the nominal operating voltage as defined by the vehicle manufacturer.]~~

~~[It is allowed to vehicle manufacturer to calculate or simulate this value instead of measuring this after the crash.]~~

Measure and record the voltage (Vb) between the negative and the positive side of the high voltage bus (see figure 1);

Measure and record the voltage (V1) between the negative side of the high voltage bus and the electrical chassis (see figure 1);

Measure and record the voltage (V2) between the positive side of the high voltage bus and the electrical chassis (see figure 1);

If V_1 is greater than or equal to V_2 , insert a standard known resistance (R_0) between the negative side of the high voltage bus and the electrical chassis. With R_0 installed, measure the voltage (V_1') between the negative side of the high voltage bus and the vehicle electrical chassis (see figure 3). Calculate the isolation resistance (R_i) according to the formula shown below.

$$R_i = R_0 * (V_b / V_1' - V_b / V_1) \quad \text{or} \quad R_i = R_0 * V_b * (1 / V_1' - 1 / V_1)$$

Divide the result R_i , which is the this-electrical isolation resistance value in ohm (Ω), by the working voltage of the high voltage bus in volts in volt (V).

$$R_i (\Omega / V) = R_i (\Omega) / \text{Working voltage (V)}$$

$$R_i = R_0 * (V_b / V_1' - V_b / V_1) \quad \text{or} \quad R_i = R_0 * V_b * (1 / V_1' - 1 / V_1)$$

Figure 3
Measurement of V_1'

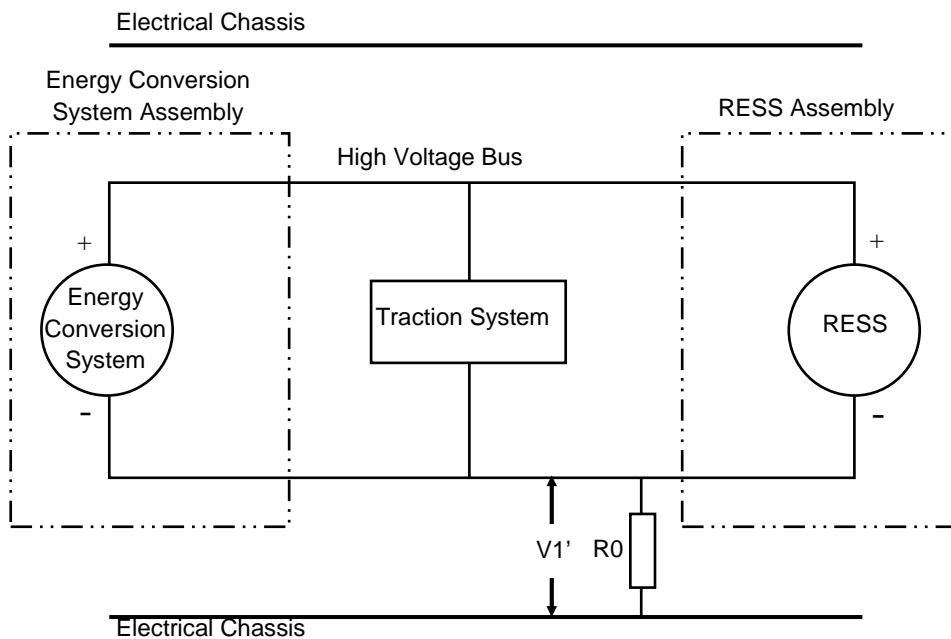

If V_2 is greater than V_1 , insert a standard known resistance (R_0) between the positive side of the high voltage bus and the electrical chassis. With R_0 installed, measure the voltage (V_2') between the positive side of the high voltage bus and the electrical chassis (see figure 4).

Calculate the isolation resistance (R_i) according to the formula shown below.

$$R_i = R_0 * (V_b / V_2' - V_b / V_2) \quad \text{or} \quad R_i = R_0 * V_b * (1 / V_2' - 1 / V_2)$$

Divide the result R_i , which is the this-electrical isolation resistance value in ohm (Ω), by the working voltage of the high voltage bus in volts in volt (V).

$$R_i (\Omega / V) = R_i (\Omega) / \text{Working voltage (V)}$$

$$R_i = R_0 * (V_b / V_2' - V_b / V_2) \quad \text{or} \quad R_i = R_0 * V_b * (1 / V_2' - 1 / V_2)$$

Figure 4
Measurement of V_2'

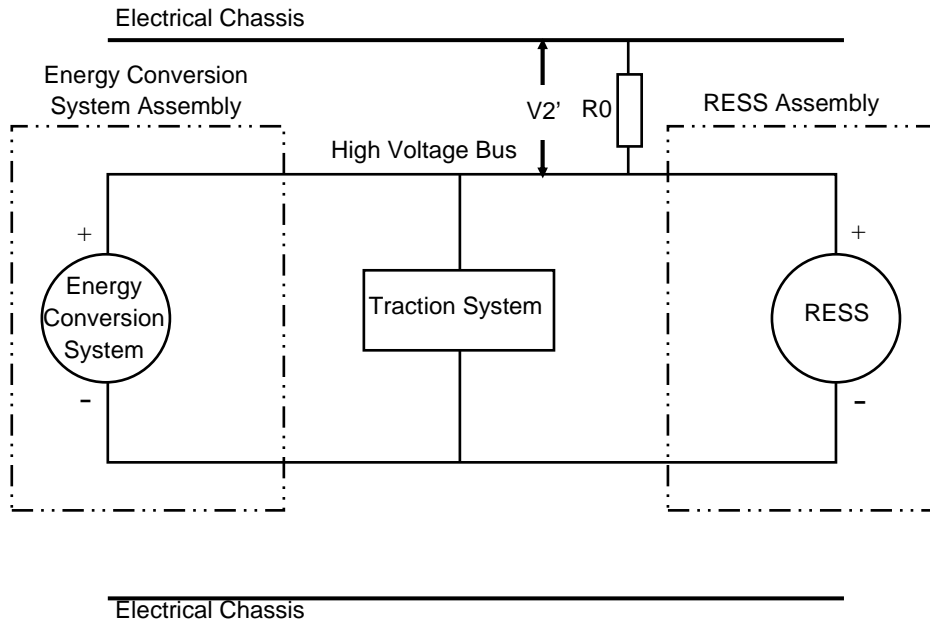

Note 1: The standard known resistance R_0 (in Ω) should be approximately 500 times the working voltage of the vehicle the value of the minimum required isolation resistance (in Ω/V) multiplied by the working voltage (in V) of the vehicle plus/minus 20 per cent in volts. R_0 is not required to be precisely this value since the equations are valid for any R_0 ; however, an R_0 value in this range should provide a good resolution for the voltage measurements.

The isolation resistance between the high voltage bus and the electrical chassis may be demonstrated by calculation, measurement or a combination of both.

6. Electrolyte spillage

Appropriate **coating paint** shall be applied, if necessary, to the ~~original~~ physical protection in order to confirm ~~the any~~ electrolyte **leakage** is leaking from the RESS after the **impact test collision**.

~~Add color to other liquid (such as coolant, oil, fuel, etc.), if necessary, so that the electrolyte and other liquid can be classified or separated.~~

~~If the electrolyte cannot be clearly identified from the other leaking liquids, all liquid shall be considered as the electrolyte.~~

Unless the manufacturer provides means to differentiate between the leakage of different liquids, all liquid leakage shall be considered as the electrolyte.

7. RESS retention

Compliance shall be determined by visual inspection

Appendix 1

Jointed test finger (IPXXB)

Protection against direct contacts of parts under voltage

1. Access probes

Access probes to verify the protection of persons against access to live parts are given in figure 1.

2. Test conditions

The access probe is pushed against any openings of the enclosure with the force specified in paragraph 4 of this annex. If it partly or fully penetrates, it is placed in every possible position, but in no case shall the stop face fully penetrate through the opening.

Internal barriers are considered part of the enclosure

A low voltage supply (of not less than 40 V and not more than 50 V) in series with a suitable lamp should be connected, if necessary, between the probe and live parts inside the barrier or enclosure.

The signal circuit method should also be applied to the moving live parts of high voltage equipment.

Internal moving parts may be operated slowly, where this is possible.

3. Acceptance conditions

The access probe shall not touch live parts.

If this requirement is verified by a signal circuit between the probe and live parts, the lamp shall not light.

In the case of the test for IPXXB, the jointed test finger may penetrate to its 80 mm length, but the stop face (diameter 50 mm x 20 mm) shall not pass through the opening. Starting from the straight position, both joints of the test finger shall be successively bent through an angle of up to 90 degree with respect to the axis of the adjoining section of the finger and shall be placed in every possible position.

Figure 1
Jointed test finger

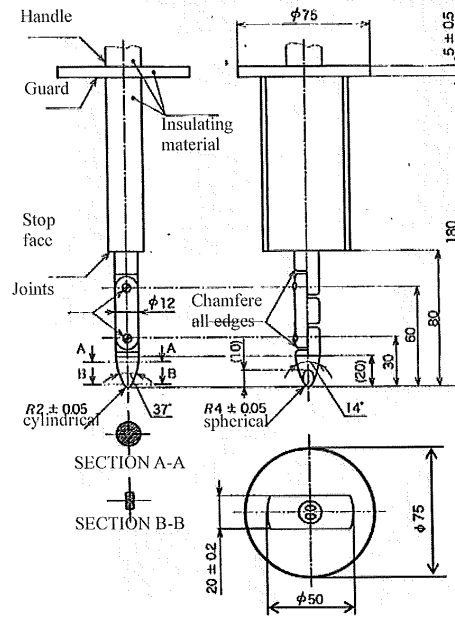

Material: metal, except where otherwise specified

Linear dimensions in millimeters

Tolerances on dimensions without specific tolerance:

- (a) on angles: 0/-10°
- (b) on linear dimensions: up to 25 mm: 0/-0.05 mm over 25 mm: ± 0.2 mm

Both joints shall permit movement in the same plane and the same direction through an angle of 90° with a 0 to +10° tolerance.”

Annex VIII

Amendments to draft regulation on pedestrian safety

Amendments adopted to ECE/TRANS/WP.29/GRSP/209/17 (see para. 43 of the report)

...

Paragraph 1, amend to read

“1. Scope

{This Regulation applies to motor vehicles of categories M₁ and N₁¹

However, vehicles of category N₁ where the driver’s position "R-point" is either forward of the front axle or longitudinally rearwards of the front axle transverse centreline by a maximum of 1100 mm, are exempted from the requirements of this Regulation.

This Regulation does not apply to vehicles of category M₁ above 2500 kg maximum mass and which are derived from N₁ category vehicles, and where the driver’s position "R-point" is either forward of the front axle or longitudinally rearwards of the front axle transverse centreline by a maximum of 1100 mm; for these vehicle categories Contracting Parties may continue to apply the requirements already in force for that purpose at the time of acceding to this Regulation.}

...

Paragraphs 11. to 11.3.2., shall be deleted

Annex 5, paragraph 3.4.3., amend to read:

“3.4.3. The areas of "HIC1000 zone " and "HIC1700 zone" may consist of several parts, with the number of these parts not being limited. **The determination of the impacted zone is done by the first contact point of the headform with the “bonnet top.”**

...

Annex IX

Informal groups of GRSP

<i>Informal group</i>	<i>Chairman</i>	<i>Secretary</i>
Truck cab strength	Mr. Vladimir Salnikov Phone : +7 495-9949917 Fax : +7 495-9949940 Email : v.salnikov@autorc.ru	(OICA)
Frontal Impact	Mr. Pierre Castaing Phone : +33 1-69801750 Fax : +33 1-69801719 Email : pierre.castaing@utac.com	
Head restraints	Mr. Bernard Frost Phone : +44-(0)207 9442107 Fax : +44-(0)207 9449623 Email : bernie.frost@dft.gsi.gov.uk	(OICA)
Hydrogen and fuel cells - sub- group safety	Mr. Kazuyuki Narusawa Phone : +81 4-22413218 Fax : +81 4-22768604 Email : narusawa@ntsel.go.jp	USA
Child restraints systems	Mr. Pierre Castaing Phone : +33 1-69801750 Fax : +33 1-69801719 Email : pierre.castaing@utac.com	
Electric safety	Mr. Heiko Mertens Phone : +49 536-1930123 Mobile : +49 151-16822235 Fax : +49 536-195749806 Email : heiko.mertens@volkswagen.de	